

**CIRCULATION MASTER PLAN
FOR
SERENO CANYON**

October 10, 2005

WP #042054.10

Prepared for:

Crown Community Development

Ms. Teri Frankiewicz

3600 Thayer Court, Suite 100

Aurora, Illinois 60504

Phone: (630) 851-5490

Fax: (630) 898-0480

Prepared by:

Wood, Patel & Associates, Inc.

2051 West Northern Avenue, Suite 100

Phoenix, Arizona 85021

Phone: (602) 335-8500

Fax: (602) 335-8580



Engineer

TABLE OF CONTENTS

1.0 INTRODUCTION.....1

 1.1 Report Purpose and Objectives1

 1.2 Executive Summary2

2.0 PROPOSED DEVELOPMENT5

 2.1 Project Description.....5

 2.2 Adjacent Land Use5

 2.3 Site Access5

3.0 EXISTING CONDITIONS6

 3.1 Existing Roadway Geometry and Intersection Control.....6

 3.2 Existing Traffic Data7

4.0 PROJECTED TRAFFIC8

 4.1 Projected Site Traffic8

 4.2 Projected Non-site Traffic (from Adjacent Developments).....8

 4.3 Total Traffic9

5.0 CAPACITY ANALYSIS10

 5.1 Traffic Control10

 5.2 Level of Service10

6.0 VEHICULAR CIRCULATION ELEMENTS11

 6.1 Roadway Circulation Plan and Cross-sections.....11

 6.2 Easement Abandonments and Right-of-way Dedications.....11

 6.3 Access to Adjacent Developments13

 6.4 Intersection Improvements14

 6.5 Auxiliary Lanes.....14

 6.5.1 Left Turn Lanes.....14

 6.5.2 Right Turn Lanes.....14

7.0 NON-VEHICULAR CIRCULATION ELEMENTS15

 7.1 Sidewalks and Bicycle Lanes.....15

 7.2 Multi-use Trails and Paths.....15

APPENDICES

Appendix A	Emergency Access Route Approval
Appendix B	Existing Traffic Counts
Appendix C	Level of Service Analysis

EXHIBITS

Exhibit 1	Vicinity Map
Exhibit 2	Study Area
Exhibit 3	Site Plan
Exhibit 4	Existing Roadway Conditions
Exhibit 5	Existing Traffic Volumes
Exhibit 6	Trip Generation
Exhibit 7	Projected and Total Traffic
Exhibit 8	Roadway Circulation Plan
Exhibit 9	Roadway Cross-sections
Exhibit 10	Roadway Easement Abandonments
Exhibit 11	Right-of-way Dedications
Exhibit 12	Access to Adjacent Developments
Exhibit 13	Multi-use Trail Plan

km

N:\2004\042054\Drawings\Exhibits\MASTER PLAN\Traffic MP\Analysis and Documentation\042054.10 Circulation MP - Final 10-10-05.doc

1.0 INTRODUCTION

1.1 Report Purpose and Objectives

Wood, Patel and Associates, Inc. (Wood/Patel) has been retained by Crown Community Development to prepare a Master Circulation Plan of a 330+/- acre proposed residential development located on the northwest corner of the 128th Street / Pinnacle Peak Road alignment in Scottsdale, Arizona, as shown in Exhibit 1. This report describes the proposed Sereno Canyon development (formerly McDowell Mountain Back Bowl project) and summarizes its impact on the adjacent street network.

The purpose of this study is to address traffic impacts of the Sereno Canyon within the study area at full site build-out and discuss roadway circulation issues associated with Sereno Canyon and other surrounding developments. The objectives of the study are as follows:

- Collect data related to roadway geometry and intersections control at facilities in the vicinity of the site;
- Estimate projected traffic at the study intersection of Alameda Road / Happy Valley Road based on existing traffic counts and projected traffic from Sereno Canyon and other developments in the vicinity;
- Perform capacity analysis at the study intersection at full site build-out and recommend any appropriate improvements at the intersection;
- Provide right-of-way dedications and cross-sections for roadways within and adjacent to the proposed development;
- Discuss access to adjacent properties;
- Summarize roadway alignments to be abandoned as part of the proposed development;

The study area in this analysis is the intersection of Alameda Road / Happy Valley Road, the segment of Alameda Road east of Happy Valley Road, and the proposed Ranch Gate Road north of the site. The study area is shown in Exhibit 2.

1.2 Executive Summary

Sereno Canyon is a gated custom home development located on the northwest corner of 128th Street / Pinnacle Peak Road alignment in Scottsdale, Arizona. The 330+/- acre site is planned to have 122 dwelling units.

The study area for this development was to include the Happy Valley Road / Alameda Road intersection, the segment of Alameda Road from Happy Valley Road to 122nd Street and the proposed Ranch Gate Road north of the site. Based on the information in the site plan and the trip generation rates in the Institute of Transportation Engineers' Trip Generation Manual, it is estimated that at full build-out, the site will generate 1,168 trips of which 92 trips will occur during the AM peak hour and 123 trips will occur during the PM peak hour. Traffic counts were collected at the study intersection and traffic from proposed adjacent developments was also considered in the analysis.

Analysis indicates that at full build-out, all movements at the study intersection are anticipated to operate at a Level of Service "B" or better during the peak hours. Further, the two-lane study segment of Alameda Road which has a capacity of up to 15,000 vehicles per day is anticipated to carry 3,850 vehicles per day. Therefore, no capacity improvements are required within the study area to accommodate the site-generated traffic.

As part of the Sereno Canyon development, several existing roadway easements will be abandoned and new rights-of-way will be dedicated. With reference to Exhibit 10, the following roadway easement abandonments are proposed as a part of the Sereno Canyon project:

1. A 55-foot easement along the Happy Valley Road alignment from the eastern edge of the Sonoran Crest Development up to the 126th Street alignment;
2. A 40-foot east-west easement from 122nd Street to the 126th Street alignment between the Happy Valley Road alignment and Alameda Road;
3. A 40-foot easement along Alameda Road from 122nd Street to the 126th Street alignment;

4. A 40-foot easement along Mariposa Grande Drive from 122nd Street to the 128th Street alignment;
5. A 55-foot easement along Pinnacle Peak Road between 122nd Street and the 124th Street alignment, and between the 126th Street alignment and 128th street;
6. A 30-foot easement along 122nd Street between the northern property line and the Pinnacle Peak Road alignment;
7. A 40-foot easement along the 124th Street alignment between the Happy Valley Road and Pinnacle Peak Road alignments;
8. A 30-foot easement along the 126th Street alignment between the Happy Valley Road and Pinnacle Peak Road alignments; and,
9. A 55-foot easement along 128th Street between Mariposa Grande Drive and the Pinnacle Peak Road alignment.

Additionally, with reference to Exhibit 11, new rights-of-way will be dedicated as listed below:

1. A 19-foot right-of-way (east half-street) for a local residential along 122nd Street from Alameda Road to 1,050 feet north of the Pinnacle Peak Road alignment;
2. A 30-foot right-of-way (west half-street) for a minor collector along 128th Street between Mariposa Grande Drive and the Pinnacle Peak Road alignment;
3. A 38-foot right-of-way for all local residential streets within the development;
4. A 25-foot right-of-way (south half-street) for a local collector along Ranch Gate Road from the 126th Street alignment east for a distance of 800 feet.
5. A 50-foot right-of-way for a local collector along for the gated entry road east of 122nd Street.
6. A potential 30-foot right-of-way (south half-street) along Mariposa Grande Drive between 128th Street and the cul-de-sac road;
7. A potential 30-foot right-of-way (west half-street) along the 126th Street alignment from 1,320 feet south of Happy Valley Road south for a distance of 390 feet.

Sidewalks, bicycle lanes and transit stops are not required within the proposed development, and will not be constructed as part of the Sereno Canyon. However, a multi-use trail system having public and private trails will be constructed to support non-motorized transportation.

2.0 PROPOSED DEVELOPMENT

2.1 Project Description

Sereno Canyon, shown earlier in Exhibits 1 and 2, is a 330+/- acre residential custom lot sub-division, located at the eastern edge of the City of Scottsdale, Maricopa County, Arizona, within a portion of Section 11, Township 4 North, Range 5 East. The site is currently an assemblage of undeveloped parcels bound to the west by the existing Sonoran Crest Development (122nd Street alignment), to the east by the 128th Street alignment, to the north by the Happy Valley Road alignment, and to the south by the McDowell Mountain Sonoran Preserve. Primary residential access to the development is planned from the west via the ½ -mile section roadway, Alameda Road. Access is also available using Ranch Gate Road immediately north of the Sereno Canyon project.

The development, shown in Exhibit 3, is planned in four (4) phases and includes approximately 122 lots ranging in size from 2 to 3 acres and a Clubhouse with amenities such as jacuzzis, pools, water falls, and restaurant facilities for internal use. Interpretive trails and scattered pocket parks with water features will also be incorporated into the site plan.

2.2 Adjacent Land Use

Adjacent parcels that are anticipated to access the regional roadway network using Alameda Road and Ranch Gate Road were considered in the study. These developments, as shown earlier in Exhibit 2, include 240 +/- acres of the Recorp Property that has parcels to the east and west of the site, 364 +/- acres of state land to the north of the site and 474 +/- acres of other land to the east of the site.

2.3 Site Access

The Sereno Canyon site will be primarily accessed from its western boundary using Alameda Road via Happy Valley Road and using Ranch Gate Road to the north.

3.0 EXISTING CONDITIONS

3.1 Existing Roadway Geometry and Intersection Control

The major roadway facilities connecting the site to the regional roadway network are Happy Valley Road, Alameda Road, Rio Verde Drive (Dynamite Boulevard) and 128th Street. These facilities are described below and shown in Exhibit 4.

Happy Valley Road is an east-west minor arterial providing connectivity to/from the west. East of Alma School Road, Happy Valley Road is a fully improved 4-lane divided facility, with two lanes in each direction, curb and gutter on both north and south sides, and a posted speed limit of 40 mph. West of Alma School Road, it is 2-lane undivided facility without curb and gutter and a posted speed limit of 50 mph.

Alameda Road branches off as a minor collector east from Happy Valley Road, and extends approximately 300 feet east of 121st Place up to the western boundary of the site. It is a 2-lane undivided facility, with curb and gutter on both north and south sides and a posted speed limit of 30 mph.

Rio Verde Drive is an east-west major arterial approximately two miles north of the site's northern boundary. It provides regional connectivity to the site through 128th Street. West of the 116th Street alignment, Rio Verde Drive is a 4-lane divided facility with two lanes in each direction. The north and south sides have wide unpaved shoulders without curb and gutter, and a sidewalk on both sides past the shoulders. East of 116th Street alignment, it is a 2-lane undivided facility with a posted speed limit of 50 mph.

128th Street is a north-south unpaved facility, which provides connectivity between Rio Verde Drive and the eastern boundary of the site. This two-mile unpaved segment of 128th Street varies in width from 22 and 24 feet.

Happy Valley Road / Alameda Road is an unsignalized intersection with stop control on Alameda Road. The east leg of the intersection along Happy Valley Road has one left turn lane, one through lane, and one shared through-right turn lane. The west leg has one left turn lane, two through lanes, and one right turn lane whereas, the south leg along

Alameda Road has one shared left-through-right lane. The north leg of the intersection falls along the 115th Street alignment and has a lane configuration matching the south leg.

Rio Verde Drive / 128th Street is a T-Intersection with stop control along 128th Street for northbound movements. The east leg along Rio Verde Drive has one shared through-left lane and the west leg has one shared through-right lane. The unpaved south leg of the intersection along 128th Street operates as one shared left-through-right lane.

3.2 Existing Traffic Data

Traffic data was collected at the Happy Valley Road / Alameda Road intersection on March 30, 2005 by Traffic Research and Analysis, Inc. Turning movement counts were collected during the AM peak period of 7:00 AM to 9:00 PM and a PM peak period of 4:00 PM to 6:00 PM. 24-hour tube counts were also collected at all four legs of the intersection. The detailed traffic counts are shown in Appendix B and summarized in Exhibit 5.

4.0 PROJECTED TRAFFIC

4.1 Projected Site Traffic

Trip Generation: A generally accepted method of calculating trip generation rates for a proposed development is to use regression equations and/or average rates developed by the *Institute of Transportation Engineers (ITE)* through the compilation of field data collected at sites throughout the United States.

The total trip generation potential for the 122 dwelling units in Sereno Canyon was calculated based on the average trip rates presented in the 7th Edition of ITE's *Trip Generation Manual* and is shown in detail in Exhibit 6. Analysis indicates that the development will generate an estimated 1,168 daily trips of which 92 trips will occur during the AM peak period and 123 trips will occur during the PM peak period. It is assumed here that all trips generated by the Clubhouse will be internally captured.

Trip Distribution: It is assumed that 80% of the traffic generated by Sereno Canyon will access the regional roadway network using Alameda Road whereas 20% traffic will access using Ranch Gate Road.

Site Traffic Assignment: Using the trip generation potential and trip distribution assumptions stated above, new site traffic was assigned to roadways in the study area as it could be expected to travel on its way to and from the site. AM and PM peak turning movements for site traffic, at the Happy Valley Road / Alameda Road intersection, are shown in Exhibit 7a.

4.2 Projected Non-site Traffic (from Adjacent Developments)

As shown in the study area in Exhibit 2, non-site traffic is comprised of traffic from the 20 Acre Exception parcel, Recorp Property, State Land, and other adjacent developments. Assuming the existing zoning density of 0.31 dwelling units per acre for these areas, the 20 Acre Exception parcel will have 6 dwelling units, Recorp Property will have 74 dwelling units, State Land will have 113 dwelling units and other adjacent properties will have 147 dwelling units.

Based on ITE Trip Generation rates, the 20 Acre Exception parcel will generate 57 daily trips (4 AM peak, 6 PM peak), the Recorp Property will generate 712 daily trips (56 AM peak, 75 PM peak), State Land will generate 1,080 daily trips (84 AM peak, 114 PM peak) and other adjacent developments will generate 1,406 daily trips (111 AM peak, 148 PM peak). It is further assumed that 80% traffic from the 20 Acre Exception parcel will use Alameda Road whereas the remainder 20% will use 128th Street to Ranch Gate Road, 100% of the traffic from Recorp Property will use 128th Street to Ranch Gate Road, 50% traffic from State Land will use Ranch Gate Road whereas the remainder 50% traffic will use Jomax Road, and 100% traffic from other adjacent properties will use 128th Street to Ranch Gate Road.

In addition to above-mentioned developments, traffic from planned developments between Happy Valley Road and Sereno Canyon along Alameda Road was also accounted for in the analysis. It is our understanding that 300 dwelling units are planned in this area that will access using Alameda Road through the Alameda Road / Happy Valle Road intersection.

Exhibit 7b shows the daily, AM peak and PM peak non-site traffic at the Happy Valley Road / Alameda Road intersection.

4.3 **Total Traffic**

Total traffic at the Happy Valley Road / Alameda Road intersection shown in Exhibit 7c was computed by adding the site traffic in Exhibit 7a to non-site traffic in Exhibit 7b. Traffic for other movements at this intersection was based on traffic counts. Results of this effort indicate that at full build-out of all planned developments mentioned above, Alameda Road will have an estimated ADT of 3,850 vehicles per day, and Ranch Gate Road will have an estimated ADT of 2,910 vehicles per day.

5.0 CAPACITY ANALYSIS

5.1 Traffic Control

Full build-out traffic operations at the Happy Valley Road / Alameda Road intersection were evaluated using total traffic presented in Exhibit 7c. Based on site conditions and projected traffic volumes, it is assumed that this intersection will continue to operate with two-way stop control, with stops along Alameda Road (115th Street).

5.2 Level of Service

The level of service (LOS) of an intersection is a measure of vehicular delay, and is evaluated based on the traffic volumes and composition, intersection control and roadway geometrics. The methodology for determining LOS is based on the Highway Capacity Manual (HCM), 2000 Edition. The level of service, as outlined in HCM, is reported as a letter designation of LOS A through LOS F, where A indicates minimal delay and F denotes substantial delay. In this study, LOS analysis for the unsignalized intersection was done using the Highway Capacity Software (HCS 2000) by McTrans-University of Florida. Results of this effort are summarized in the table below and the detailed output for the unsignalized intersection analysis is given in Appendix C.

Full Build-out LOS Analysis at Happy Valley Road / Alameda Road

Movement	Street	Delay	Level of Service	
			AM	PM
Eastbound Left	From Happy Valley Road	7.4 sec / veh	A	A
Westbound Left	From Happy Valley Road	7.4 sec / veh	A	A
Northbound Approach	From Alameda Road	11.2 sec / veh	B	B
Southbound Approach	From 115 th Street	8.8 sec / veh	A	A

Results of the analysis indicate that at full site build-out, all movements at the intersection of Happy Valley Road / Alameda Road operate at a LOS "B" or better during the AM and PM peak hours. No additional capacity improvements are therefore recommended to accommodate the site traffic. Also, no capacity evaluations were done at intersections within the site as all such intersections are expected to operate at LOS "A" during the AM and PM peak hours given the low density of residential units in the Sereno Canyon development.

6.0 VEHICULAR CIRCULATION ELEMENTS

6.1 Roadway Circulation Plan and Cross-sections

Roadway circulation was planned in order to best serve and connect the various residential units to the regional roadway network. The proposed Roadway Circulation Plan shown in Exhibit 8, and the corresponding proposed cross-sections shown in Exhibit 9, were developed based on criteria outlined in the City of Scottsdale's *Design Guidelines and Policies for Environmentally Sensitive Lands* for Hillside development.

The gated entrance (private) to Sereno Canyon is planned to align with Alameda Road, which is a Minor Collector providing connectivity to Happy Valley Road. Ranch Gate Road on the northern boundary of the site is planned to be a Local Collector. All other roads within Sereno Canyon which will connect the residential units to the site entrances are planned as Local Residential Streets. Half-street improvements along 128th Street between Mariposa Grande Drive and Pinnacle Peak Road may not be completed as part of the Sereno Canyon project as they are not needed to support the development. However, it is our understanding that 118th Street will be improved from Ranch Gate Road to Jomax Road.

6.2 Easement Abandonments and Right-of-way Dedications

All existing roadway and utility easements within the Sereno Canyon development are abandoned as a part of this project. Roadway easement abandonments proposed as a part of the *Sereno Canyon* project are shown in Exhibit 10 and listed below:

1. A 55-foot easement along the Happy Valley Road alignment from the eastern edge of the Sonoran Crest Development up to the 126th Street alignment;
2. A 40-foot east-west easement from 122nd Street to the 126th Street alignment between the Happy Valley Road alignment and Alameda Road;
3. A 40-foot easement along Alameda Road from 122nd Street to the 126th Street alignment;
4. A 40-foot easement along Mariposa Grande Drive from 122nd Street to the 128th Street alignment;

5. A 55-foot easement along Pinnacle Peak Road between 122nd Street and the 124th Street alignment, and between the 126th Street alignment and 128th street;
6. A 30-foot easement along 122nd Street between the northern property line and the Pinnacle Peak Road alignment;
7. A 40-foot easement along the 124th Street alignment between the Happy Valley Road and Pinnacle Peak Road alignments;
8. A 30-foot easement along the 126th Street alignment between the Happy Valley Road and Pinnacle Peak Road alignments; and,
9. A 55' easement along 128th Street between Mariposa Grande Drive and the Pinnacle Peak Road alignment.

In addition to the easement abandonments described above, new rights-of-way will be dedicated. These right-of-way dedications are presented in Exhibit 11 and listed below:

1. A 19-foot right-of-way (east half-street) for a local residential along 122nd Street from Alameda Road to 1,050 feet north of the Pinnacle Peak Road alignment;
2. A 30-foot right-of-way (west half-street) for a minor collector along 128th Street between Mariposa Grande Drive and the Pinnacle Peak Road alignment;
3. A 38-foot right-of-way for all local residential streets within the development;
4. A 25-foot right-of-way (south half-street) for a local collector along Ranch Gate Road from the 126th Street alignment east for a distance of 800 feet.
5. A 50-foot right-of-way for a local collector along for the gated entry road east of 122nd Street.

Additionally, right-of-way will be provided, if required, for the following locations. The *Sereno Canyon* project will be phased as shown on exhibits. Final plats will be phased similarly. An update to the Circulation Master Plan will be completed as part of each future phase to determine if the following right-of-way requirements are still required as a result of development occurring on the adjacent parcels.

6. A potential 30-foot right-of-way (south half-street) along Mariposa Grande Drive between 128th Street and the cul-de-sac road;

7. A potential 30-foot right-of-way (west half-street) along the 126th Street alignment from 1,320 feet south of Happy Valley Road south for a distance of 390 feet.

6.3 Access to Adjacent Developments

External access to adjacent developments (shown in Exhibit 12 as Parcels 1 through 13) within the study area is anticipated using the surrounding roadway network and through internal connections between these developments.

Access to Parcel 1 is anticipated using 122nd Street. Access to Parcel 2 is anticipated through the development to its northwest using Casitas Del Rio Drive. Access to Parcels 3, 4, and 5 is also anticipated using Casitas Del Rio Drive through internal connections within these parcels, whereas access to Parcel 6 (20 Acre Exception parcel) will be provided on its northeast corner through the *Sereno Canyon* development. Emergency access will be provided through Sereno Canyon as agreed to by the owner of Parcels 3, 4, and 5 (see Appendix A). Access using Pinnacle Peak Road is not anticipated for these parcels, primarily due to topographic challenges. The Preliminary Plat for Parcel 1 has not indicated right-of-way provision along the Pinnacle Peak roadway alignment, due to this topographic challenge.

Access to Parcel 7 will be provided through the northwestern portion of the *Sereno Canyon* property. It should be noted that development of 122nd Street within Parcel 7 is planned entirely outside of the Sereno Canyon's right-of-way. Access to Parcels 8 and 11 is anticipated using 128th Street north of Sereno Canyon's right-of way and to Parcels 9 and 10 using Alameda Road. Access to Parcel 12 may be potentially provided through the Sereno Canyon development north of Alameda Road along the eastern property line, unless the site development plan does not rely on this access consideration. Access to Parcel 13 may be anticipated through the cul-de-sac entrance on Mariposa Grande Drive, although we understand that Parcels 10, 11 and 13 are under single ownership and the site development plan may not incorporate the existing Mariposa Grande Drive right-of-way.

It is our understanding that 118th Street will be improved from Ranch Gate Road to Jomax Road thereby providing connectivity for adjacent developments to the regional road network.

6.4 Intersection Improvements

As mentioned in earlier sections of this report, the Happy Valley Road / Alameda Road intersection will be the primary access point to the Sereno Canyon development. However, due to the satisfactory traffic operation of this intersection during the AM and PM peak hours, no additional improvements are recommended to accommodate the site traffic.

6.5 Auxiliary Lanes

6.5.1 Left Turn Lanes

The need for a northbound left turn lane at Happy Valley Road / Alameda Road was assessed using guidelines for left-turn lanes on two-lane roadways as outlined in A Policy on Geometric Design of Highways and Streets published by the American Association of State Highway and Transportation Officials in 2004. These guidelines are based on peak-hour traffic volumes (opposing and advancing volumes) and the percentage of left turns at the intersection. Based on AASHTO criteria, an auxiliary left turn lane will not be needed for the northbound left turn at the intersection.

6.5.2 Right Turn Lanes

The need for a right turn lane at an intersection depends on the speed of traffic on the road, the right turning volume and the through traffic volumes. The City of Scottsdale currently requires that a right turn lane be provided where right turning vehicles exceed 30 vehicles per hour. The Federal Highway Administration's Access Management for Streets and Highways provides the following minimum criteria for the provision of right turn deceleration lanes:

- Greater than 10,000 vehicles per day on the major streets;
- Highway speed at least 35 mph;
- Greater than 1,000 vehicles per day on the minor street;
- At least 40 ingress right turns during the peak period.

As there is already an eastbound right turn lane from Happy Valley Road on to Alameda Road, the need for a right turn deceleration lane was not assessed.

7.0 NON-VEHICULAR CIRCULATION ELEMENTS

7.1 Sidewalks and Bicycle Lanes

According to the City of Scottsdale standards, sidewalks are optional in Environmentally Sensitive Lands (ESL) overlay area. If sidewalks are provided, they may be on one or both sides of the roadway. Currently, no sidewalks or bike lanes are planned within the community but a network of multi-use trails is planned as described in the following section.

7.2 Multi-use Trails and Paths

Public and private multi-use trails are proposed as part of the *Sereno Canyon* development as shown in Exhibit 13. A public multi-use trail is planned on the west side of 128th Street. Apart from the public trail, a network of private multi-use trails is also planned to serve the residents of the community. These trails are anticipated to be a minimum of 8 feet wide and will primarily follow the alignment of the local residential streets within the community.



APPENDIX A

Emergency Access Route Approval

Message
From: Steven Voss [sjvoss@lvadesign.com]
Sent: Tuesday, June 14, 2005 4:37 PM
To: dgulino@ldservices.net
Cc: 'Frankiewicz, Teri'
Subject: Fw: 40 acres

----- Original Message -----

From: Gregory Belsher
To: 'Steven Voss'
Cc: Gregg Wolin ; Gary Jones
Sent: Tuesday, June 14, 2005 2:27 PM
Subject: RE: 40 acres

Steven,

Please accept this email as our approval of the conceptual emergency circulation plan prepared by Wood Patel as illustrated on its "Right of Way Exhibit" prepared in conjunction with the planning of the Crown property north of our 40-acre parcel. As the Wood Patel plan is conceptual in nature, we reserve the right to work with the staff of the City to modify the plan as we undertake the planning of our parcel.

If you have any questions, please do not hesitate to call.

Gregory S. Belsher
INCA Capital, LLC
701 N. Scottsdale Rd., Suite 165
Scottsdale, AZ 85253
80-947-5900 x17 Phone
80-947-5335 Fax
gbelsher@incacapital.com
www.incacapital.com



APPENDIX B
Existing Traffic Counts

Start Date: 3/30/2005
Start Time: 04:00 PM
Site Code: 5080

Street Name	From North ALAMEDA RD				From East HAPPY VALLEY RD				From South ALAMEDA RD				From West HAPPY VALLEY RD				INTSEC	HOOR
	Left	Thru	Right	Peds	Left	Thru	Right	Peds	Left	Thru	Right	Peds	Left	Thru	Right	Peds	TOTAL	TOTAL
Start Time																		
4:00 PM	2	0	7	0	2	9	1	0	15	1	1	0	8	6	13	0	65	
4:15 PM	0	1	7	0	1	4	0	0	14	1	0	0	11	6	10	0	55	
4:30 PM	0	0	14	0	0	4	0	0	9	0	0	0	12	13	13	0	65	
4:45 PM	1	1	11	0	0	4	0	0	11	0	0	0	5	8	7	0	48	233
5:00 PM	0	0	7	0	0	5	0	0	5	0	3	0	15	17	8	0	60	228
5:15 PM	0	1	10	0	1	4	0	0	7	0	0	0	10	12	13	0	58	231
5:30 PM	0	0	8	0	0	6	0	0	12	2	0	0	15	9	19	0	71	237
5:45 PM	0	1	8	0	1	6	0	0	14	0	0	0	12	15	14	0	71	260
Approach Total	79				48				95				271				493	
Grand Total	3	4	72	0	5	42	1	0	87	4	4	0	88	86	97	0	493	
Approach %	3.8%	5.1%	91.1%	0.0%	10.4%	87.5%	2.1%	0.0%	91.6%	4.2%	4.2%	0.0%	32.5%	31.7%	35.8%	0.0%		
Total %	0.6%	0.8%	14.6%	0.0%	1.0%	8.5%	0.2%	0.0%	17.6%	0.8%	0.8%	0.0%	17.8%	17.4%	19.7%	0.0%		
Begin Peak Hour:	17:00																	
Peak Interval:	17:30																	
Peak Hour Vol:	0	2	33	0	2	21	0	0	38	2	3	0	52	53	54	0	260	
Percent:	0.0%	0.8%	12.7%	0.0%	0.8%	8.1%	0.0%	0.0%	14.6%	0.8%	1.2%	0.0%	20.0%	20.4%	20.8%	0.0%		
Intvl Vol:	0	0	8	0	0	6	0	0	12	2	0	0	15	9	19	0	71	
Peak Factor:																	0.9155	
High Interval:	17:15				17:45				17:30				17:30					
High Intvl Vol:	0	1	10	0	1	6	0	0	12	2	0	0	15	9	19	0		
Peak Factor:	0.7955				0.8214				0.7679				0.9244					

Start Date: 3/30/2005
Start Time: 07:00 AM
Site Code: 5080

Street Name	From North ALAMEDA RD				From East HAPPY VALLEY RD				From South ALAMEDA RD				From West HAPPY VALLEY RD				INTSEC	HOURL
	Left	Thru	Right	Peds	Left	Thru	Right	Peds	Left	Thru	Right	Peds	Left	Thru	Right	Peds	TOTAL	TOTAL
Start Time																		
7:00 AM	0	0	10	0	1	16	1	0	9	0	0	0	8	5	7	0	57	
7:15 AM	0	0	19	0	1	10	1	0	12	0	1	0	13	3	11	0	71	
7:30 AM	0	1	15	0	0	15	1	0	11	0	0	0	11	2	3	0	59	
7:45 AM	1	0	22	0	0	18	0	0	18	1	0	0	9	5	7	0	81	268
8:00 AM	0	0	17	0	1	14	0	0	17	1	1	0	13	1	9	0	74	285
8:15 AM	1	1	15	0	1	15	1	0	18	0	4	0	12	8	9	0	85	299
8:30 AM	0	0	16	0	1	12	0	0	8	1	0	0	9	6	12	0	65	305
8:45 AM	0	0	8	0	4	10	0	0	19	1	0	0	17	8	10	0	77	301
Approach Total	126				123				122				198				569	
Grand Total	2	2	122	0	9	110	4	0	112	4	6	0	92	38	68	0	569	
Approach %	1.6%	1.6%	96.8%	0.0%	7.3%	89.4%	3.3%	0.0%	91.8%	3.3%	4.9%	0.0%	46.5%	19.2%	34.3%	0.0%		
Total %	0.4%	0.4%	21.4%	0.0%	1.6%	19.3%	0.7%	0.0%	19.7%	0.7%	1.1%	0.0%	16.2%	6.7%	12.0%	0.0%		
Begin Peak Hour:	7:45																	
Peak Interval:	8:15																	
Peak Hour Vol:	2	1	70	0	3	59	1	0	61	3	5	0	43	20	37	0	305	
Percent:	0.7%	0.3%	23.0%	0.0%	1.0%	19.3%	0.3%	0.0%	20.0%	1.0%	1.6%	0.0%	14.1%	6.6%	12.1%	0.0%		
Intvl Vol:	1	1	15	0	1	15	1	0	18	0	4	0	12	8	9	0	85	
Peak Factor:																	0.8971	
High Interval:	7:45				7:45				8:15				8:15					
High Intvl Vol:	1	0	22	0	0	18	0	0	18	0	4	0	12	8	9	0		
Peak Factor:					0.7935				0.8750				0.7841				0.8621	

Traffic Research and Analysis, Inc.
 3844 East Indian School Road
 Phoenix, AZ 85018
 (602) 840-1500

Site ID	File Name	Route	Location	Direction	Count Type	Count Dur	Start Date	Start Time	Avg Vol	AM PkHr	AM PkVol	AM PHF	PM PkHr	PM PkVol	PM PHF	Latitude	Longitude
1	0504750	HAPPY VALLEY RD	W. of ALAMEDA RD/115TH ST	EB	VOL	24	3/30/2005	0:00	1945	8:15	149	0.8098	17:15	165	0.8967	33.7027	-111.8343
1	0504751	HAPPY VALLEY RD	W. of ALAMEDA RD/115TH ST	WB	VOL	24	3/30/2005	0:00	1973	7:30	215	0.8669	14:30	159	0.9464	33.7027	-111.8343
2	0504753	HAPPY VALLEY RD	E. of ALAMEDA RD/115TH ST	EB	VOL	24	3/30/2005	0:00	572	9:15	42	0.8750	17:00	53	0.6974	33.7071	-111.8316
2	0504752	HAPPY VALLEY RD	E. of ALAMEDA RD/115TH ST	WB	VOL	24	3/30/2005	0:00	426	7:30	56	0.8235	14:15	33	0.8250	33.7071	-111.8316
3	0504755	115TH ST	N. of HAPPY VALLEY RD	NB	VOL	24	3/30/2005	0:00	721	8:45	68	0.8500	12:45	59	0.7375	33.7075	-111.8329
3	0504754	115TH ST	N. of HAPPY VALLEY RD	SB	VOL	24	3/30/2005	0:00	723	7:15	79	0.7900	12:45	60	0.8333	33.7075	-111.8329
4	0504756	ALAMEDA RD	S. of HAPPY VALLEY RD	NB	VOL	24	3/30/2005	0:00	775	9:15	77	0.8750	15:15	66	0.8684	33.7060	-111.8310
4	0504757	ALAMEDA RD	S. of HAPPY VALLEY RD	SB	VOL	24	3/30/2005	0:00	769	8:15	55	0.8594	14:30	72	0.8182	33.7060	-111.8310

Client: WOOD, PATEL
 File Number: 0504750
 Route: HAPPY VALLEY RD
 Location: W. of ALAMEDA RD/115TH ST

3844 East Indian School Road
 Phoenix, AZ 85018
 (602) 840-1500

Site Ref: 1
 Direction: EB
 Latitude: 33.7027
 Longitude: -111.8343

Count Date		3/30/2005																Average	
Count Time	AM	PM	AM	PM	AM	PM	AM	PM	AM	PM	AM	PM	AM	PM	AM	PM	AM	PM	
12:00	0	30																0	30
12:15	2	29																2	29
12:30	1	27																1	27
12:45	2	29																2	29
01:00	0	28																0	28
01:15	0	31																0	31
01:30	0	45																0	45
01:45	1	30																1	30
02:00	0	31																0	31
02:15	0	36																0	36
02:30	0	30																0	30
02:45	0	40																0	40
03:00	0	42																0	42
03:15	0	29																0	29
03:30	0	33																0	33
03:45	0	31																0	31
04:00	0	28																0	28
04:15	1	29																1	29
04:30	0	37																0	37
04:45	1	21																1	21
05:00	0	40																0	40
05:15	2	34																2	34
05:30	6	43																6	43
05:45	11	46																11	46
06:00	17	42																17	42
06:15	22	32																22	32
06:30	20	30																20	30
06:45	19	23																19	23
07:00	23	34																23	34
07:15	31	22																31	22
07:30	18	28																18	28
07:45	25	15																25	15
08:00	26	18																26	18
08:15	31	15																31	15
08:30	33	18																33	18
08:45	39	27																39	27
09:00	46	21																46	21
09:15	30	19																30	19
09:30	29	20																29	20
09:45	33	9																33	9
10:00	24	15																24	15
10:15	39	6																39	6
10:30	21	7																21	7
10:45	19	14																19	14
11:00	34	11																34	11
11:15	26	4																26	4
11:30	39	3																39	3
11:45	38	4																38	4
Totals	709	1236	0	0	0	0	0	0	0	0	0	0	0	0	0	0	0	709	1236
Day Total	1945		0	0	0	0	0	0	0	0	0	0	0	0	0	0	0	1945	
AM Pct	36.5%																	36.5%	
Peak Hour	8:15	17:15																8:15	17:15
Peak Volume	149	165																149	165
P.H.F	0.8098	0.8967																0.8098	0.8967

Client: WOOD, PATEL
 File Number: 0504751
 Route: HAPPY VALLEY RD
 Location: W. of ALAMEDA RD/115TH ST

Traffic Search & Analysis, Inc.
 3844 East Indian School Road
 Phoenix, AZ 85018
 (602) 840-1500

Site Ref: 1
 Direction: WB
 Latitude: 33.7027
 Longitude: -111.8343

Count Date		3/30/2005																Average	
Count Time	AM	PM	AM	PM	AM	PM	AM	PM	AM	PM	AM	PM	AM	PM	AM	PM	AM	PM	
12:00	0	30																0	30
12:15	0	26																0	26
12:30	0	30																0	30
12:45	0	25																0	25
01:00	1	34																1	34
01:15	0	42																0	42
01:30	0	30																0	30
01:45	1	26																1	26
02:00	0	33																0	33
02:15	2	30																2	30
02:30	0	38																0	38
02:45	0	42																0	42
03:00	0	37																0	37
03:15	0	42																0	42
03:30	1	30																1	30
03:45	0	33																0	33
04:00	1	34																1	34
04:15	0	27																0	27
04:30	1	30																1	30
04:45	5	31																5	31
05:00	5	22																5	22
05:15	9	21																9	21
05:30	10	27																10	27
05:45	14	28																14	28
06:00	21	17																21	17
06:15	26	16																26	16
06:30	45	13																45	13
06:45	42	14																42	14
07:00	41	12																41	12
07:15	49	12																49	12
07:30	48	6																48	6
07:45	62	6																62	6
08:00	51	11																51	11
08:15	54	2																54	2
08:30	41	5																41	5
08:45	39	8																39	8
09:00	45	3																45	3
09:15	50	7																50	7
09:30	35	2																35	2
09:45	59	4																59	4
10:00	49	6																49	6
10:15	35	1																35	1
10:30	38	3																38	3
10:45	38	1																38	1
11:00	47	3																47	3
11:15	37	0																37	0
11:30	32	1																32	1
11:45	36	2																36	2
Totals	1070	903	0	0	0	0	0	0	0	0	0	0	0	0	0	0	0	1070	903
Day Total	1973																1973		
AM Pct	54.2%																54.2%		
Peak Hour	7:30	14:30																7:30	14:30
Peak Volume	215	159																215	159
P.H.F	0.8669	0.9464																0.8669	0.9464

Client: WOOD, PATEL
 File Number: 0504752
 Route: HAPPY VALLEY RD
 Location: E. of ALAMEDA RD/115TH ST

3844 East Indian School Road
 Phoenix, AZ 85018
 (602) 840-1500

Site Ref: 2
 Direction: WB
 Latitude: 33.7071
 Longitude: -111.8316

Count Date 3/30/2005																	Average			
Count Time	AM	PM	AM	PM	AM	PM	AM	PM	AM	PM	AM	PM	AM	PM	AM	PM	AM	PM		
12:00	0	7															0	7		
12:15	0	7															0	7		
12:30	0	5															0	5		
12:45	0	3															0	3		
01:00	0	4															0	4		
01:15	0	7															0	7		
01:30	0	6															0	6		
01:45	0	6															0	6		
02:00	0	4															0	4		
02:15	0	8															0	8		
02:30	0	10															0	10		
02:45	0	9															0	9		
03:00	0	6															0	6		
03:15	0	7															0	7		
03:30	1	8															1	8		
03:45	0	3															0	3		
04:00	0	11															0	11		
04:15	0	4															0	4		
04:30	0	2															0	2		
04:45	1	3															1	3		
05:00	3	4															3	4		
05:15	2	4															2	4		
05:30	6	5															6	5		
05:45	2	6															2	6		
06:00	4	5															4	5		
06:15	3	5															3	5		
06:30	11	3															11	3		
06:45	8	3															8	3		
07:00	16	3															16	3		
07:15	8	5															8	5		
07:30	15	2															15	2		
07:45	13	3															13	3		
08:00	11	2															11	2		
08:15	17	2															17	2		
08:30	10	0															10	0		
08:45	12	2															12	2		
09:00	10	0															10	0		
09:15	10	4															10	4		
09:30	10	0															10	0		
09:45	10	0															10	0		
10:00	17	3															17	3		
10:15	3	2															3	2		
10:30	7	0															7	0		
10:45	8	0															8	0		
11:00	7	1															7	1		
11:15	4	0															4	0		
11:30	6	1															6	1		
11:45	5	1															5	1		
Totals	240	186	0	0	0	0	0	0	0	0	0	0	0	0	0	0	240	186		
Day Total	426		0		0		0		0		0		0		0		426			
AM Pct	56.3%																		56.3%	
Peak Hour	7:30	14:15																	7:30	14:15
Peak Volume	56	33																	56	33
P.H.F	0.8235	0.8250																	0.8235	0.8250

Traffic Research & Analysis, Inc.
 3844 East Indian School Road
 Phoenix, AZ 85018
 (602) 840-1500

Client: WOOD, PATEL
 File Number: 0504753
 Route: HAPPY VALLEY RD
 Location: E. of ALAMEDA RD/115TH ST

Site Ref: 2
 Direction: EB
 Latitude: 33.7071
 Longitude: -111.8316

Count Date		3/30/2005																Average			
Count Time	AM	PM	AM	PM	AM	PM	AM	PM	AM	PM	AM	PM	AM	PM	AM	PM	AM	PM			
12:00	0	11																0	11		
12:15	0	6																0	6		
12:30	0	3																0	3		
12:45	1	6																1	6		
01:00	0	8																0	8		
01:15	0	10																0	10		
01:30	0	8																0	8		
01:45	1	9																1	9		
02:00	0	8																0	8		
02:15	0	13																0	13		
02:30	0	4																0	4		
02:45	0	12																0	12		
03:00	0	14																0	14		
03:15	0	7																0	7		
03:30	0	12																0	12		
03:45	0	12																0	12		
04:00	0	9																0	9		
04:15	1	9																1	9		
04:30	0	10																0	10		
04:45	0	9																0	9		
05:00	0	19																0	19		
05:15	1	13																1	13		
05:30	0	6																0	6		
05:45	1	15																1	15		
06:00	2	10																2	10		
06:15	3	10																3	10		
06:30	7	13																7	13		
06:45	2	12																2	12		
07:00	6	13																6	13		
07:15	6	8																6	8		
07:30	2	12																2	12		
07:45	7	5																7	5		
08:00	2	7																2	7		
08:15	14	3																14	3		
08:30	8	4																8	4		
08:45	9	11																9	11		
09:00	7	6																7	6		
09:15	9	4																9	4		
09:30	11	6																11	6		
09:45	10	3																10	3		
10:00	12	3																12	3		
10:15	9	1																9	1		
10:30	4	6																4	6		
10:45	9	3																9	3		
11:00	13	8																13	8		
11:15	6	3																6	3		
11:30	7	3																7	3		
11:45	11	4																11	4		
Totals	181	391	0	0	0	0	0	0	0	0	0	0	0	0	0	0	0	181	391		
Day Total	572		0		0		0		0		0		0		0		0	572			
AM Pct	31.6%																	31.6%			
Peak Hour	9:15	17:00																		9:15	17:00
Peak Volume	42	53																		42	53
P.H.F	0.8750	0.6974																		0.8750	0.6974

Client: WOOD, PATEL
 File Number: 0504754
 Route: 115TH ST
 Location: N. of HAPPY VALLEY RD

Site Ref: 3
 Direction: SB
 Latitude: 33.7075
 Longitude: -111.8329

Count Date		3/30/2005														Average				
Count Time	AM	PM	AM	PM	AM	PM	AM	PM	AM	PM	AM	PM	AM	PM	AM	PM	AM	PM		
12:00	0	10																	0	10
12:15	0	6																	0	6
12:30	0	12																	0	12
12:45	0	13																	0	13
01:00	1	17																	1	17
01:15	0	12																	0	12
01:30	0	18																	0	18
01:45	1	11																	1	11
02:00	0	14																	0	14
02:15	0	9																	0	9
02:30	0	13																	0	13
02:45	0	14																	0	14
03:00	0	16																	0	16
03:15	0	17																	0	17
03:30	0	13																	0	13
03:45	0	10																	0	10
04:00	1	9																	1	9
04:15	0	9																	0	9
04:30	1	14																	1	14
04:45	3	14																	3	14
05:00	2	9																	2	9
05:15	2	11																	2	11
05:30	2	8																	2	8
05:45	5	9																	5	9
06:00	8	5																	8	5
06:15	16	4																	16	4
06:30	14	5																	14	5
06:45	12	3																	12	3
07:00	10	2																	10	2
07:15	21	1																	21	1
07:30	15	1																	15	1
07:45	25	0																	25	0
08:00	18	4																	18	4
08:15	16	0																	16	0
08:30	16	3																	16	3
08:45	8	1																	8	1
09:00	21	3																	21	3
09:15	20	2																	20	2
09:30	8	1																	8	1
09:45	23	2																	23	2
10:00	14	0																	14	0
10:15	18	0																	18	0
10:30	12	1																	12	1
10:45	18	1																	18	1
11:00	17	0																	17	0
11:15	19	0																	19	0
11:30	13	0																	13	0
11:45	15	1																	15	1
Totals	395	328	0	0	0	0	0	0	0	0	0	0	0	0	0	0	0	0	395	328
Day Total	723		0		0		0		0		0		0		0		0		723	
AM Pct	54.6%																			
Peak Hour	7:15	12:45																		
Peak Volume	79	60																		
P.H.F	0.7900	0.8333																		

Traffic Research & Analysis, Inc.
 3844 East Indian School Road
 Phoenix, AZ 85018
 (602) 840-1500

Client: WOOD, PATEL
 File Number: 0504755
 Route: 115TH ST
 Location: N. of HAPPY VALLEY RD

Site Ref: 3
 Direction: NB
 Latitude: 33.7075
 Longitude: -111.8329

Count Date		3/30/2005																Average	
Count Time	AM	PM	AM	PM	AM	PM	AM	PM	AM	PM	AM	PM	AM	PM	AM	PM	AM	PM	
12:00	0	9																0	9
12:15	1	13																1	13
12:30	0	13																0	13
12:45	0	14																0	14
01:00	0	13																0	13
01:15	0	12																0	12
01:30	0	20																0	20
01:45	0	10																0	10
02:00	0	8																0	8
02:15	0	13																0	13
02:30	0	9																0	9
02:45	0	12																0	12
03:00	0	13																0	13
03:15	0	8																0	8
03:30	0	13																0	13
03:45	0	9																0	9
04:00	0	11																0	11
04:15	0	9																0	9
04:30	0	17																0	17
04:45	1	4																1	4
05:00	0	10																0	10
05:15	1	14																1	14
05:30	0	16																0	16
05:45	4	10																4	10
06:00	6	12																6	12
06:15	8	15																8	15
06:30	11	12																11	12
06:45	5	4																5	4
07:00	8	11																8	11
07:15	15	7																15	7
07:30	12	6																12	6
07:45	12	8																12	8
08:00	14	6																14	6
08:15	14	6																14	6
08:30	9	7																9	7
08:45	19	9																19	9
09:00	20	2																20	2
09:15	16	10																16	10
09:30	13	8																13	8
09:45	10	2																10	2
10:00	9	6																9	6
10:15	15	1																15	1
10:30	11	3																11	3
10:45	9	5																9	5
11:00	8	0																8	0
11:15	14	0																14	0
11:30	14	0																14	0
11:45	22	0																22	0
Totals	301	420	0	0	0	0	0	0	0	0	0	0	0	0	0	0	0	301	420
Day Total	721		0		0		0		0		0		0		0		0	721	
AM Pct	41.7%																	41.7%	
Peak Hour	8:45	12:45																8:45	12:45
Peak Volume	68	59																68	59
P.H.F	0.8500	0.7375																0.8500	0.7375

Traffic Research Analysis, Inc.
 3844 East Indian School Road
 Phoenix, AZ 85018
 (602) 840-1500

Client: WOOD, PATEL
 File Number: 0504756
 Route: ALAMEDA RD
 Location: S. of HAPPY VALLEY RD

Site Ref: 4
 Direction: NB
 Latitude: 33.7060
 Longitude: -111.8310

Count Date		3/30/2005																Average	
Count Time	AM	PM	AM	PM	AM	PM	AM	PM	AM	PM	AM	PM	AM	PM	AM	PM	AM	PM	
12:00	0	16																0	16
12:15	0	9																0	9
12:30	0	15																0	15
12:45	0	10																0	10
01:00	0	17																0	17
01:15	0	19																0	19
01:30	0	10																0	10
01:45	0	12																0	12
02:00	0	18																0	18
02:15	1	13																1	13
02:30	0	13																0	13
02:45	0	20																0	20
03:00	0	13																0	13
03:15	0	19																0	19
03:30	0	13																0	13
03:45	0	18																0	18
04:00	0	16																0	16
04:15	1	14																1	14
04:30	0	10																0	10
04:45	1	11																1	11
05:00	0	9																0	9
05:15	5	11																5	11
05:30	2	11																2	11
05:45	2	14																2	14
06:00	10	7																10	7
06:15	7	10																7	10
06:30	14	6																14	6
06:45	14	6																14	6
07:00	9	9																9	9
07:15	13	4																13	4
07:30	12	6																12	6
07:45	18	2																18	2
08:00	21	3																21	3
08:15	22	0																22	0
08:30	10	1																10	1
08:45	19	5																19	5
09:00	9	1																9	1
09:15	16	0																16	0
09:30	22	1																22	1
09:45	20	2																20	2
10:00	19	3																19	3
10:15	15	0																15	0
10:30	20	1																20	1
10:45	11	0																11	0
11:00	21	0																21	0
11:15	13	0																13	0
11:30	13	0																13	0
11:45	17	0																17	0
Totals	377	398	0	0	0	0	0	0	0	0	0	0	0	0	0	0	0	377	398
Day Total	775		0	0	0	0	0	0	0	0	0	0	0	0	0	0	0	775	
AM Pct	48.6%																	48.6%	
Peak Hour	9:15	15:15																9:15	15:15
Peak Volume	77	66																77	66
P.H.F	0.8750	0.8684																0.8750	0.8684

Traffic Search & Analysis, Inc.
 3844 East Indian School Road
 Phoenix, AZ 85018
 (602) 840-1500

Client: WOOD, PATEL
 File Number: 0504757
 Route: ALAMEDA RD
 Location: S. of HAPPY VALLEY RD

Site Ref: 4
 Direction: SB
 Latitude: 33.7060
 Longitude: -111.8310

Count Date		3/30/2005														Average		
Count Time	AM	PM	AM	PM	AM	PM	AM	PM	AM	PM	AM	PM	AM	PM	AM	PM	Average AM	Average PM
12:00	0	12															0	12
12:15	1	13															1	13
12:30	1	9															1	9
12:45	1	13															1	13
01:00	0	12															0	12
01:15	0	10															0	10
01:30	0	21															0	21
01:45	0	14															0	14
02:00	0	18															0	18
02:15	0	13															0	13
02:30	0	16															0	16
02:45	0	22															0	22
03:00	0	16															0	16
03:15	0	18															0	18
03:30	0	16															0	16
03:45	0	8															0	8
04:00	0	14															0	14
04:15	1	12															1	12
04:30	0	15															0	15
04:45	1	6															1	6
05:00	0	10															0	10
05:15	0	13															0	13
05:30	5	19															5	19
05:45	4	16															4	16
06:00	9	24															9	24
06:15	9	8															9	8
06:30	7	8															7	8
06:45	13	9															13	9
07:00	7	11															7	11
07:15	14	9															14	9
07:30	5	11															5	11
07:45	7	3															7	3
08:00	11	7															11	7
08:15	11	5															11	5
08:30	14	8															14	8
08:45	14	6															14	6
09:00	16	10															16	10
09:15	7	6															7	6
09:30	12	6															12	6
09:45	17	3															17	3
10:00	7	9															7	9
10:15	17	5															17	5
10:30	9	1															9	1
10:45	8	2															8	2
11:00	11	1															11	1
11:15	11	1															11	1
11:30	17	0															17	0
11:45	12	1															12	1
Totals	279	490	0	0	0	0	0	0	0	0	0	0	0	0	0	0	279	490
Day Total	769		0		0		0		0		0		0		0		769	
AM Pct	36.3%																36.3%	
Peak Hour	8:15	14:30															8:15	14:30
Peak Volume	55	72															55	72
P.H.F	0.8594	0.8182															0.8594	0.8182



APPENDIX C

Level of Service Analysis

TWO-WAY STOP CONTROL SUMMARY

General Information		Site Information	
Analyst	Chintan J.	Intersection	Happy Valley / Alameda
Agency/Co.	Wood, Patel & Associates, Inc.	Jurisdiction	City of Scottsdale
Date Performed	9/28/05	Analysis Year	Build-out
Analysis Time Period	AM Peak		

Project Description: <i>Sereno Canyon - Traffic MP</i>	
East/West Street: <i>Happy Valley Road</i>	North/South Street: <i>Alameda Road</i>
Intersection Orientation: <i>East-West</i>	Study Period (hrs): <i>0.25</i>

Vehicle Volumes and Adjustments

Major Street	Eastbound			Westbound			
	Movement	1	2	3	4	5	6
		L	T	R	L	T	R
Volume (veh/h)		43	36	75	3	73	1
Peak-hour factor, PHF		1.00	1.00	1.00	1.00	1.00	1.00
Hourly Flow Rate (veh/h)		43	36	75	3	73	1
Proportion of heavy vehicles, P _{HV}		0	--	--	0	--	--
Median type	<i>Raised curb</i>						
RT Channelized?				0			0
Lanes		1	2	1	1	2	0
Configuration		L	T	R	L	T	TR
Upstream Signal			0			0	

Minor Street	Northbound			Southbound			
	Movement	7	8	9	10	11	12
		L	T	R	L	T	R
Volume (veh/h)		226	3	5	2	1	70
Peak-hour factor, PHF		1.00	1.00	1.00	1.00	1.00	1.00
Hourly Flow Rate (veh/h)		226	3	5	2	1	70
Proportion of heavy vehicles, P _{HV}		0	0	0	0	0	0
Percent grade (%)		0			0		
Flared approach			N			N	
Storage			0			0	
RT Channelized?				0			0
Lanes		0	1	0	0	1	0
Configuration			LTR			LTR	

Control Delay, Queue Length, Level of Service

Approach	EB	WB	Northbound			Southbound		
			7	8	9	10	11	12
Movement	1	4	7	8	9	10	11	12
Lane Configuration	L	L		LTR			LTR	
Volume, v (vph)	43	3		234			73	
Capacity, c _m (vph)	1538	1492		812			1020	
v/c ratio	0.03	0.00		0.29			0.07	
Queue length (95%)	0.09	0.01		1.19			0.23	

Control Delay (s/veh)	7.4	7.4		11.2			8.8
LOS	A	A		B			A
Approach delay (s/veh)	--	--	11.2			8.8	
Approach LOS	--	--	B			A	

TWO-WAY STOP CONTROL SUMMARY

General Information		Site Information	
Analyst	Chintan J.	Intersection	Happy Valley / Alameda
Agency/Co.	Wood, Patel & Associates, Inc.	Jurisdiction	City of Scottsdale
Date Performed	9/28/05	Analysis Year	Build-out
Analysis Time Period	PM Peak		

Project Description <i>Sereno Canyon - Traffic MP</i>	
East/West Street: <i>Happy Valley Road</i>	North/South Street: <i>Alameda Road</i>
Intersection Orientation: <i>East-West</i>	Study Period (hrs): <i>0.25</i>

Vehicle Volumes and Adjustments						
Major Street	Eastbound			Westbound		
Movement	1	2	3	4	5	6
	L	T	R	L	T	R
Volume (veh/h)	52	58	256	2	30	0
Peak-hour factor, PHF	1.00	1.00	1.00	1.00	1.00	1.00
Hourly Flow Rate (veh/h)	52	58	256	2	30	0
Proportion of heavy vehicles, P _{HV}	0	--	--	0	--	--
Median type	<i>Raised curb</i>					
RT Channelized?			0			0
Lanes	1	2	1	1	2	0
Configuration	L	T	R	L	T	TR
Upstream Signal		0			0	

Minor Street	Northbound			Southbound		
Movement	7	8	9	10	11	12
	L	T	R	L	T	R
Volume (veh/h)	150	2	3	10	2	33
Peak-hour factor, PHF	1.00	1.00	1.00	1.00	1.00	1.00
Hourly Flow Rate (veh/h)	150	2	3	10	2	33
Proportion of heavy vehicles, P _{HV}	0	0	0	0	0	0
Percent grade (%)	0			0		
Flared approach		N			N	
Storage		0			0	
RT Channelized?			0			0
Lanes	0	1	0	0	1	0
Configuration		LTR			LTR	



Control Delay, Queue Length, Level of Service								
Approach	EB	WB	Northbound			Southbound		
Movement	1	4	7	8	9	10	11	12
Lane Configuration	L	L	LTR			LTR		
Volume, v (vph)	52	2	155			45		
Capacity, c _m (vph)	1596	1258	786			959		
v/c ratio	0.03	0.00	0.20			0.05		
Queue length (95%)	0.10	0.00	0.73			0.15		

Control Delay (s/veh)	7.3	7.9		10.7			8.9	
LOS	A	A		B			A	
Approach delay (s/veh)	--	--	10.7			8.9		
Approach LOS	--	--	B			A		

EXHIBIT 1

Vicinity Map

LEGEND

- Project Boundary
-  Project Site
-  McDowell Sonoran Preserve

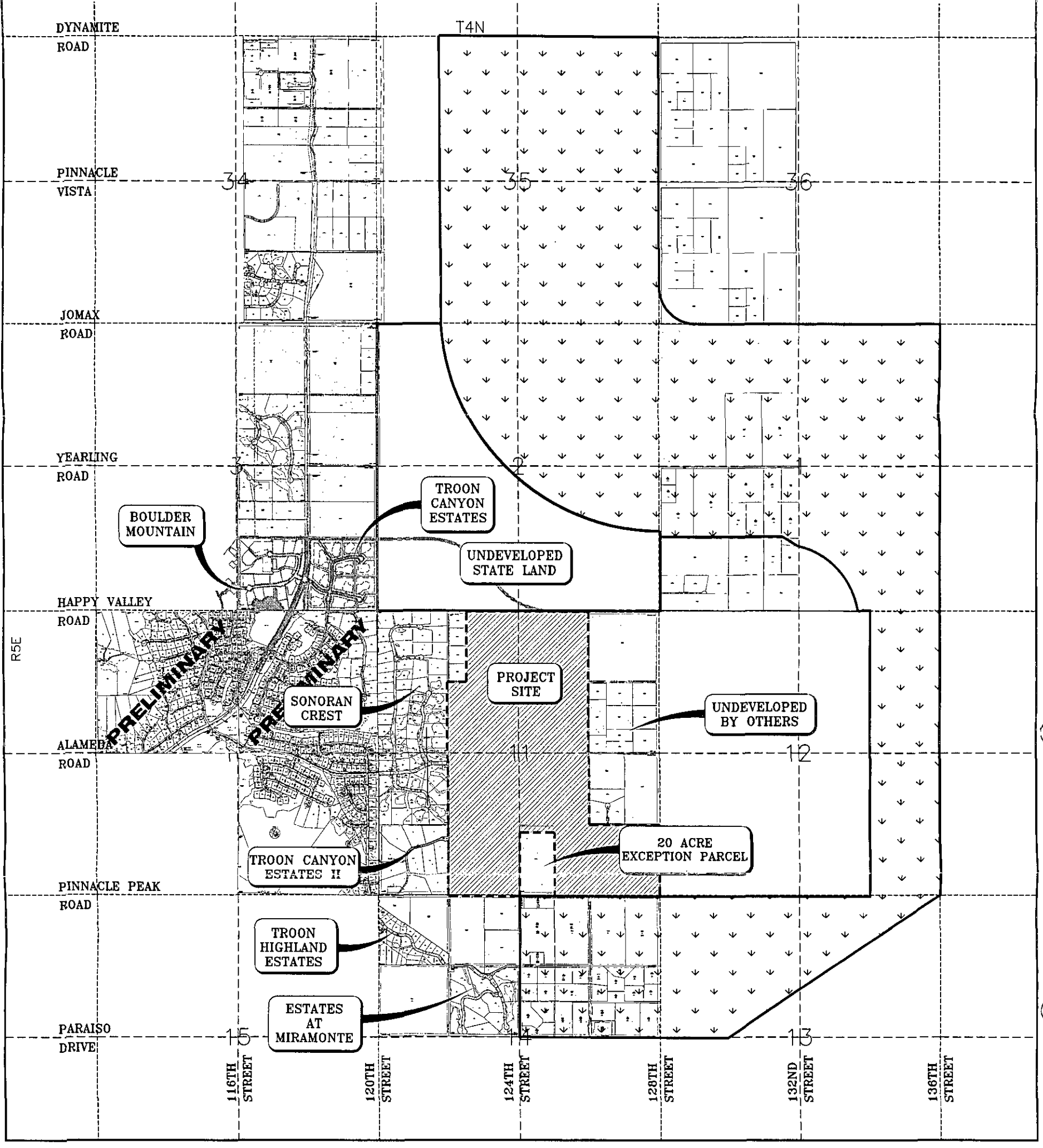
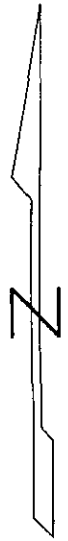
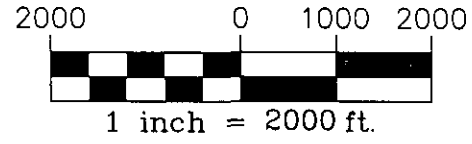

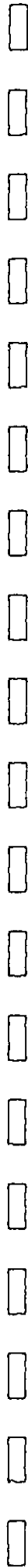

EXHIBIT 2

Study Area

WOOD/PATEL

Sereno Canyon

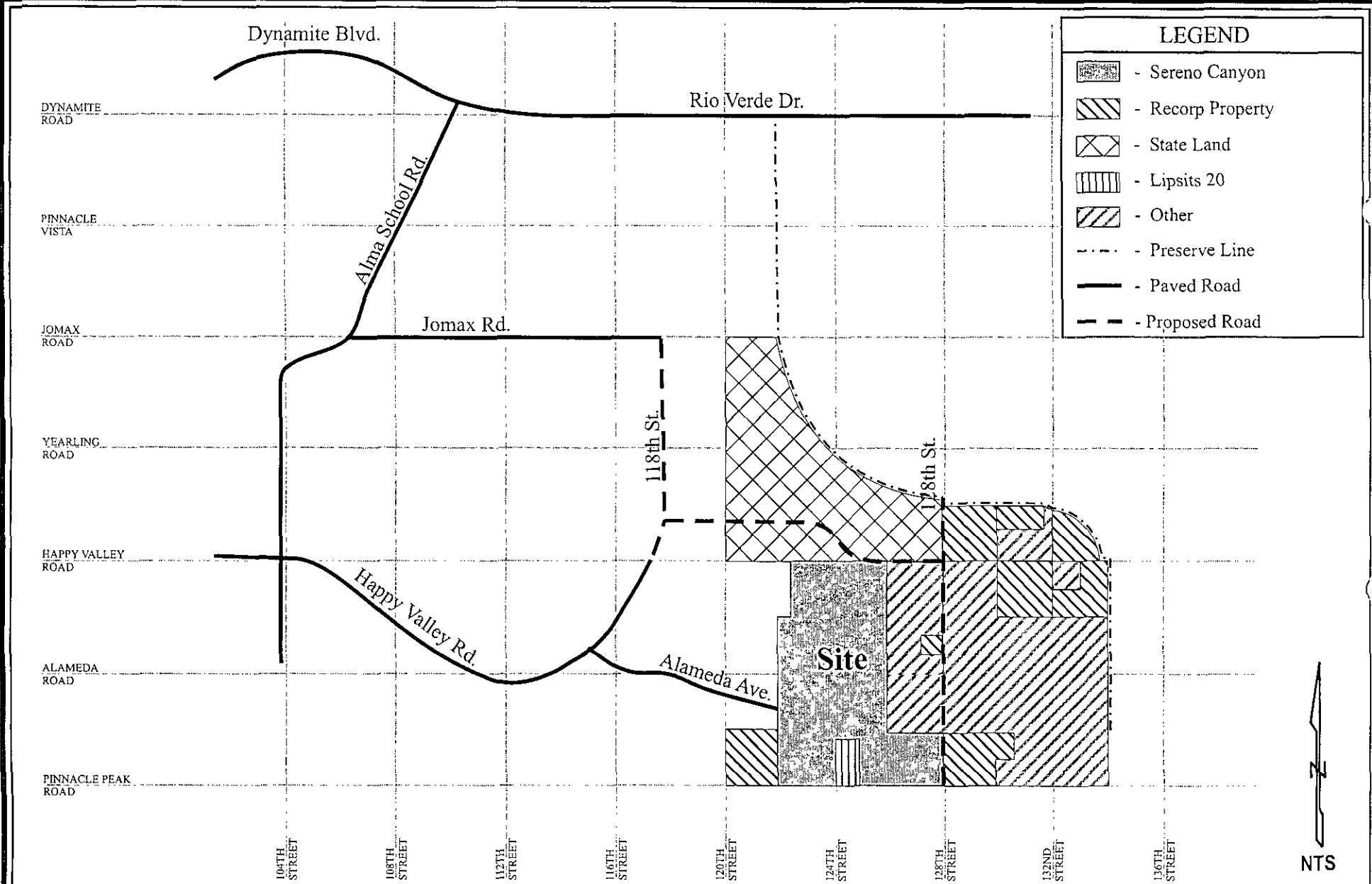

EXHIBIT 2

Study Area



EXHIBIT 3

Site Plan

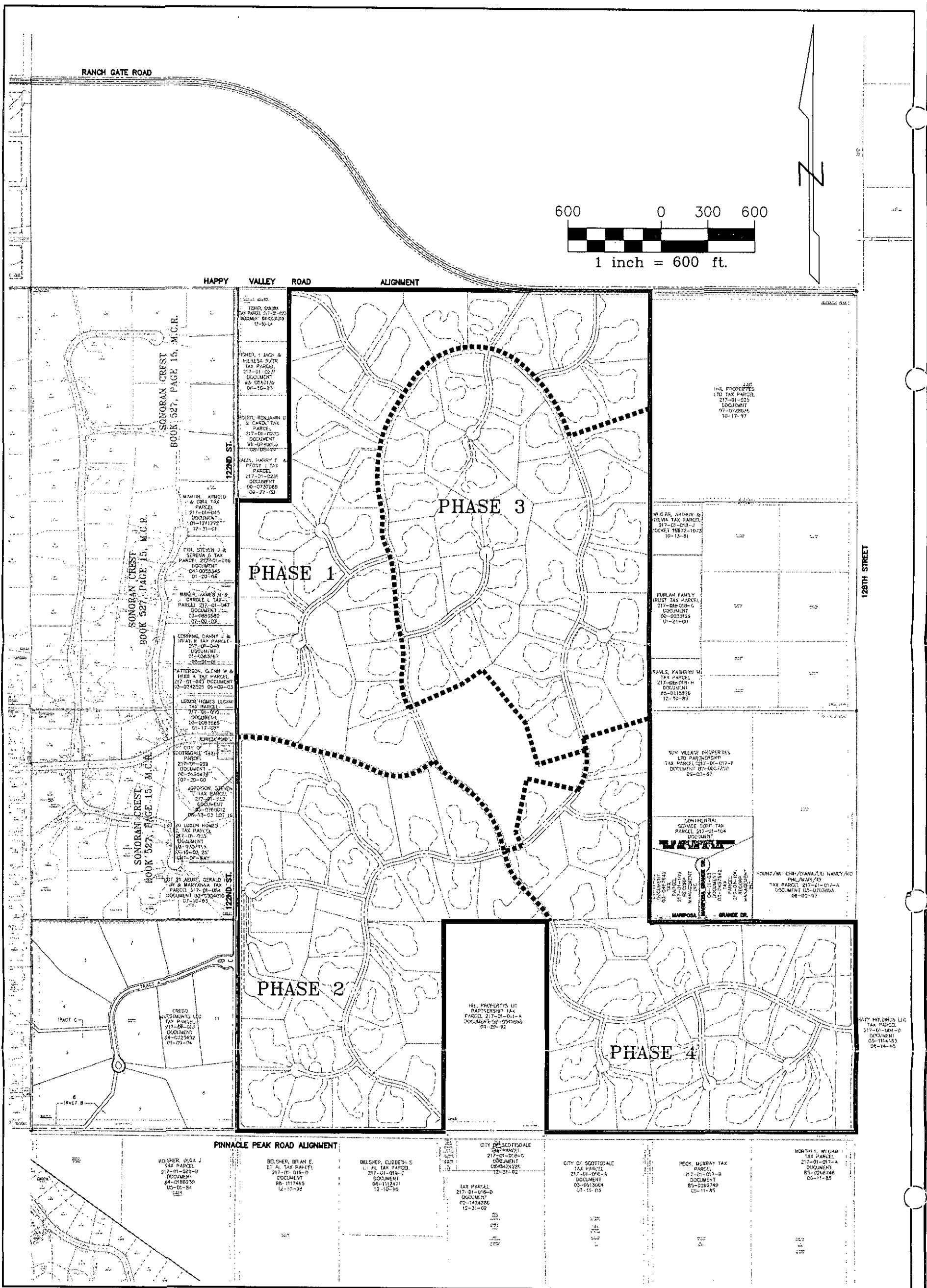

EXHIBIT 3

Site Plan



EXHIBIT 4

Existing Roadway Conditions

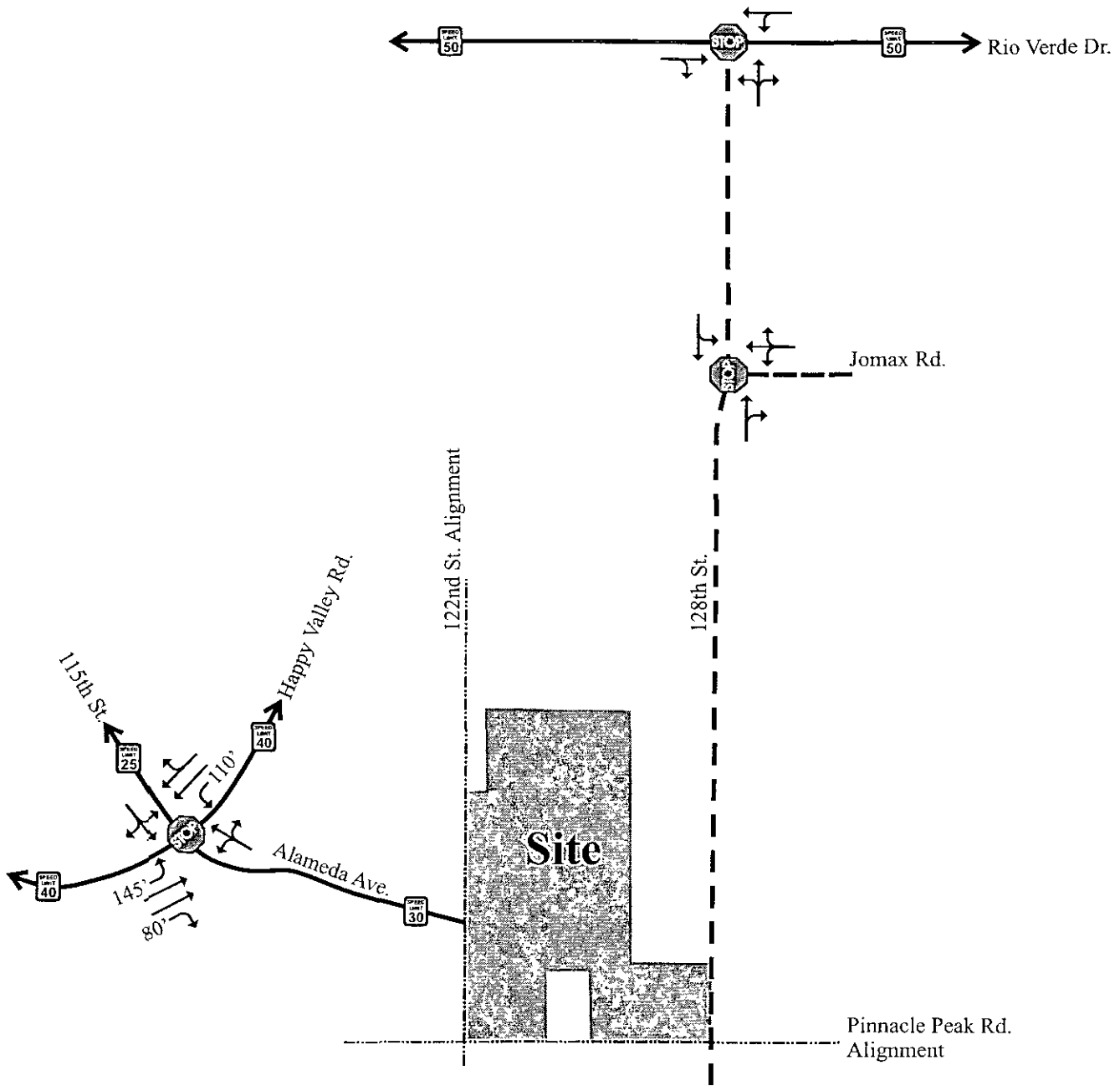

LEGEND	
	- Paved Road
	- Unpaved Road
	- Stop for East-West Movements
	- Stop for North-South Movements
	- Through Lane
	- Shared Thru-left Lane
	- Shared Thru-right Lane
	- Shared Left-thru-right Lane
	- Posted Speed Limit of 35 mph



 NTS



EXHIBIT 5

Existing Traffic Volumes

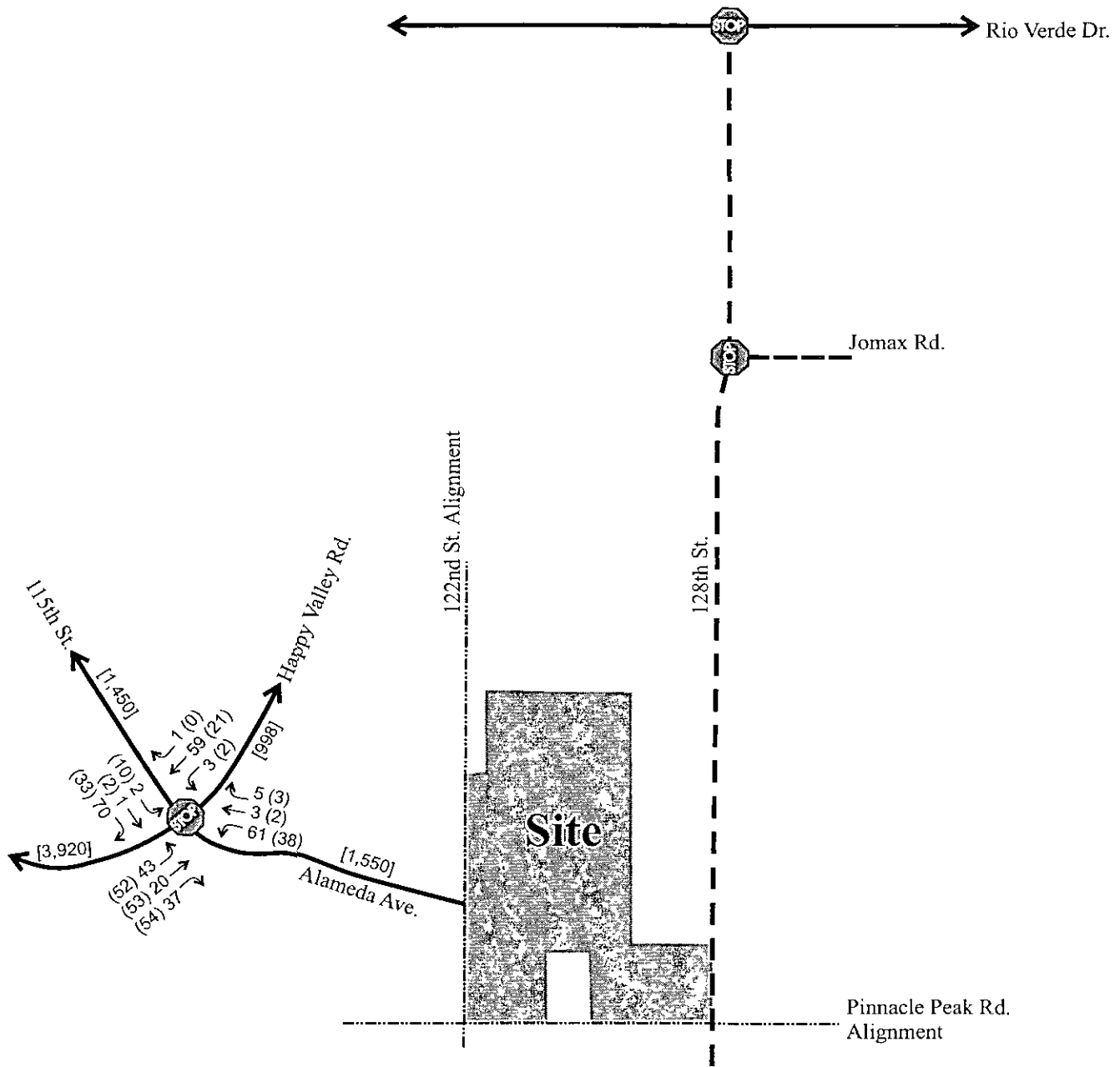

LEGEND	
	- Paved Road
	- Unpaved Road
xxx ↗	- Left Turning Traffic Volume
xxx →	- Through Traffic Volume
xxx ↘	- Right Turning Traffic Volume
[xxx]	- Segment Average Daily Traffic
AM (PM)	- AM and PM Peak Hour Traffic





EXHIBIT 6

Trip Generation

WOOD/PATEL

EXHIBIT 6: TRIP GENERATION

CIVIL ENGINEERS * HYDROLOGISTS * LAND SURVEYORS

Project: Sereno Canyon
 Location: Scottsdale, Arizona Scottsdale, Arizona
 Date: October 5, 2005.

W/P Job: 042054.10
 Engineer: Ashish Sabnekar, P.E.
 Analyst: Chintan Jhaveri, E.I.T.

	Sereno Canyon	Adjacent Properties				Total Trips
		20 Acre Exception Parcel	Recorp Property	State Land	Others	
Land Use	Single Family Residential	Single Family Residential	Single Family Residential	Single Family Residential	Single Family Residential	
Land Use Code (LUC)	210	210	210	210	210	
LUC Name	Detached Housing	Detached Housing	Detached Housing	Detached Housing	Detached Housing	
LUC Variable	D. U.	D. U.	D. U.	D. U.	D. U.	
Land Area (acres)	333	20	240	364	474	
Assumed Density (D.U./acre)	0.36	0.31	0.31	0.31	0.31	
Amount (D.U.)	122	6	74	113	147	
RATE (Average Rates)*						
Weekday	9.57	9.57	9.57	9.57	9.57	
AM Peak Hour	0.75	0.75	0.75	0.75	0.75	
PM Peak Hour	1.01	1.01	1.01	1.01	1.01	
Percent Inbound:						
AM Peak Hour	25%	25%	25%	25%	25%	
PM Peak Hour	63%	63%	63%	63%	63%	
Interaction Factor	0%	0%	0%	0%	0%	
TRIPS						
Weekday:	1,168	57	712	1,080	1,406	4,423
AM Pk Hr Inbound	23	1	14	21	28	87
AM Pk Hr Outbound	69	3	42	63	83	260
PM Pk Hr Inbound	78	4	47	72	93	294
PM Pk Hr Outbound	46	2	28	42	55	173
Pass-by Percentage:						
AM Peak Hour	0%	0%	0%	0%	0%	
PM Peak Hour	0%	0%	0%	0%	0%	
Pass-by Trip Ends AM	0	0	0	0	0	
Pass-by Trip Ends PM	0	0	0	0	0	

Source: Trip Generation Manual, 7th Edition, Institute of Transportation Engineers, 2003.

*Source: Trip Generation Manual, 7th Edition, Institute of Transportation Engineers, 2003.

EXHIBIT 7

Projected and Total Traffic

7A: Projected Site Traffic Volumes
(From Sereno Canyon)

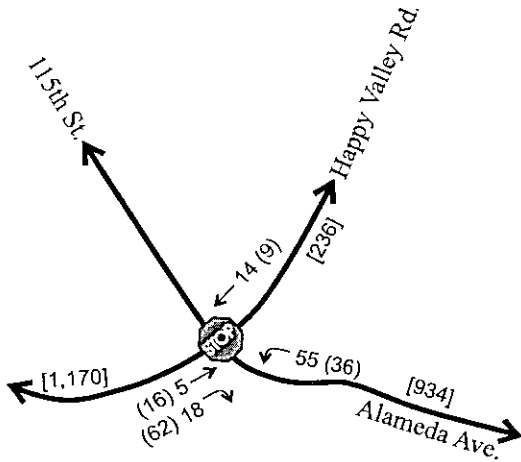

7B: Projected Non-site Traffic Volumes
(From 20 acre exception parcel + development along Alameda Road, between Happy Valley Road and Sereno Canyon)

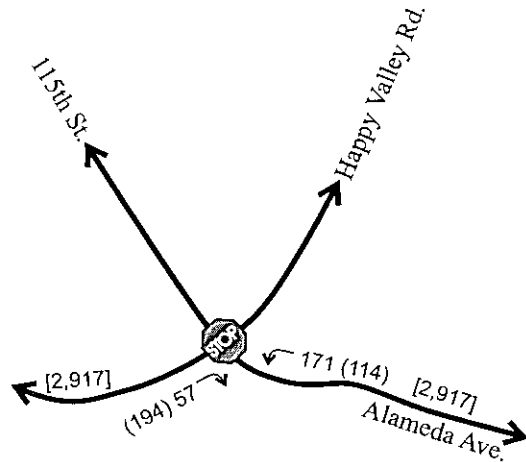

7C: Total Traffic Volumes

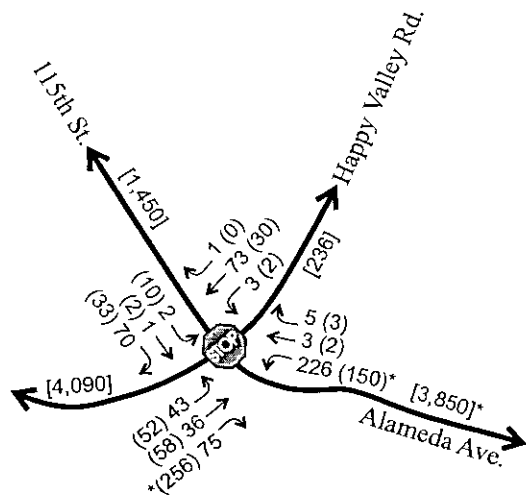

Note:
* Estimated traffic from 7A and 7 B.
All other turn movements are based on traffic counts conducted on 03/30/2005.

LEGEND

- xxx ↗ - Left Turning Traffic Volume
- xxx → - Through Traffic Volume
- xxx ↘ - Right Turning Traffic Volume
- [xxx] - Segment Average Daily Traffic
- AM (PM) - AM and PM Peak Hour Traffic



EXHIBIT 8

Roadway Circulation Plan

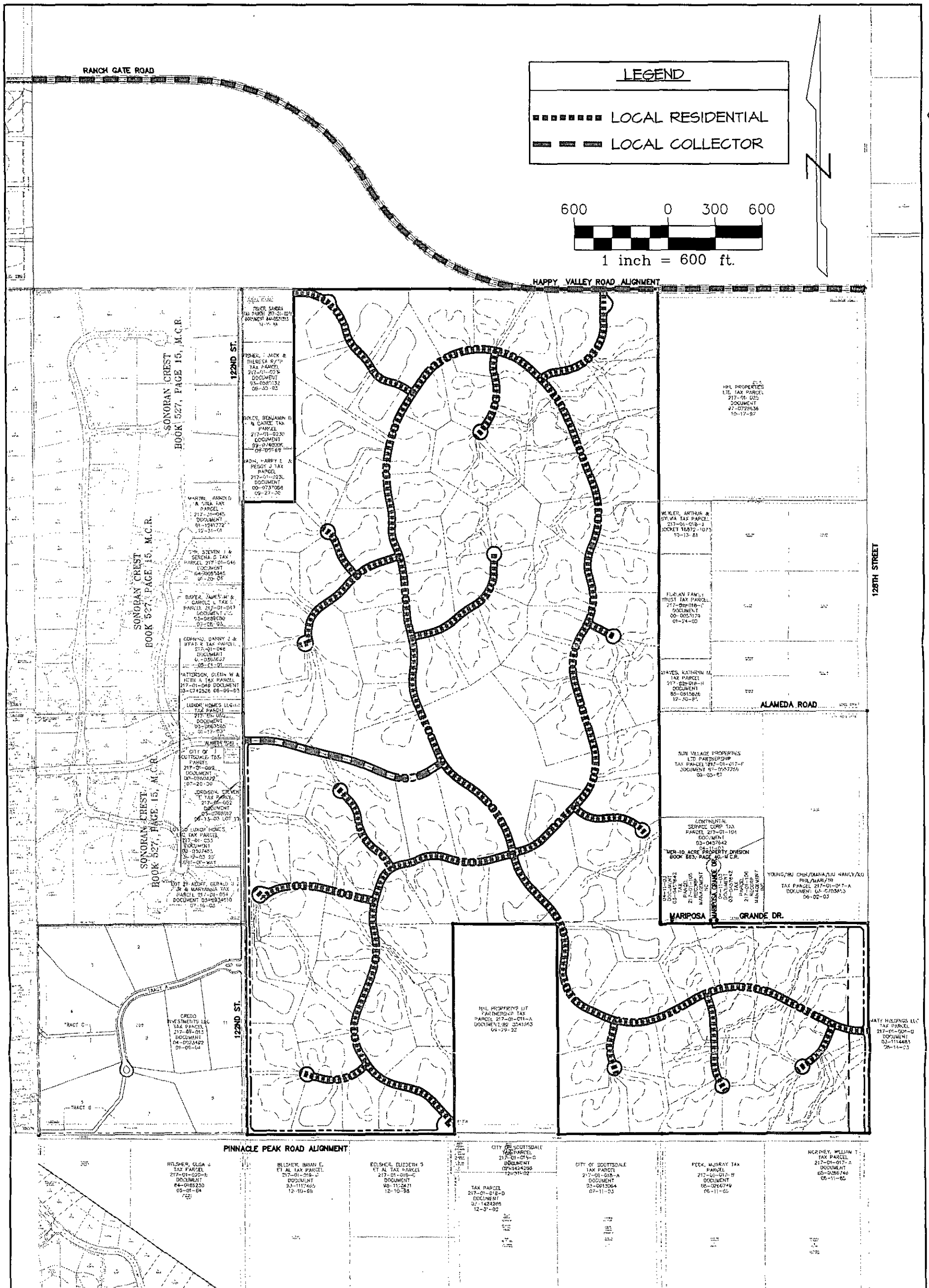

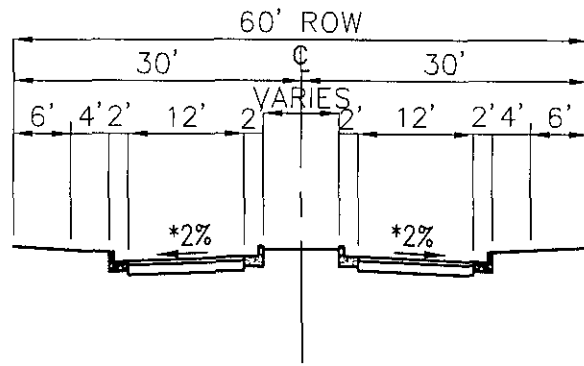

**MINOR COLLECTOR
WITH MEDIAN**

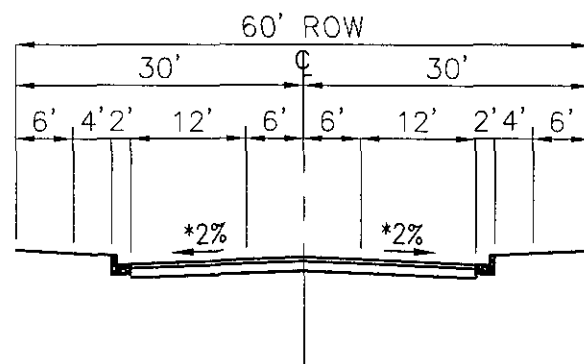

**MINOR COLLECTOR
NO MEDIAN**

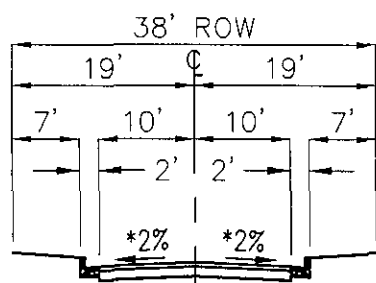

**LOCAL RESIDENTIAL
STREET**

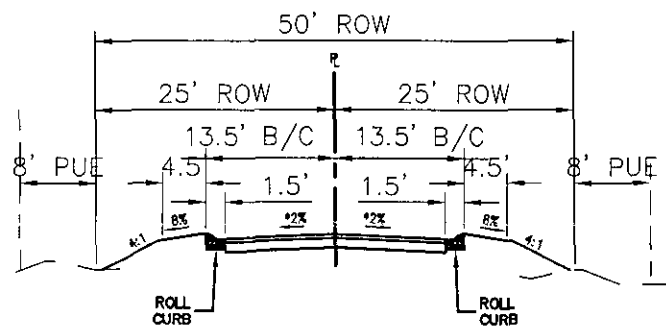

LOCAL COLLECTOR

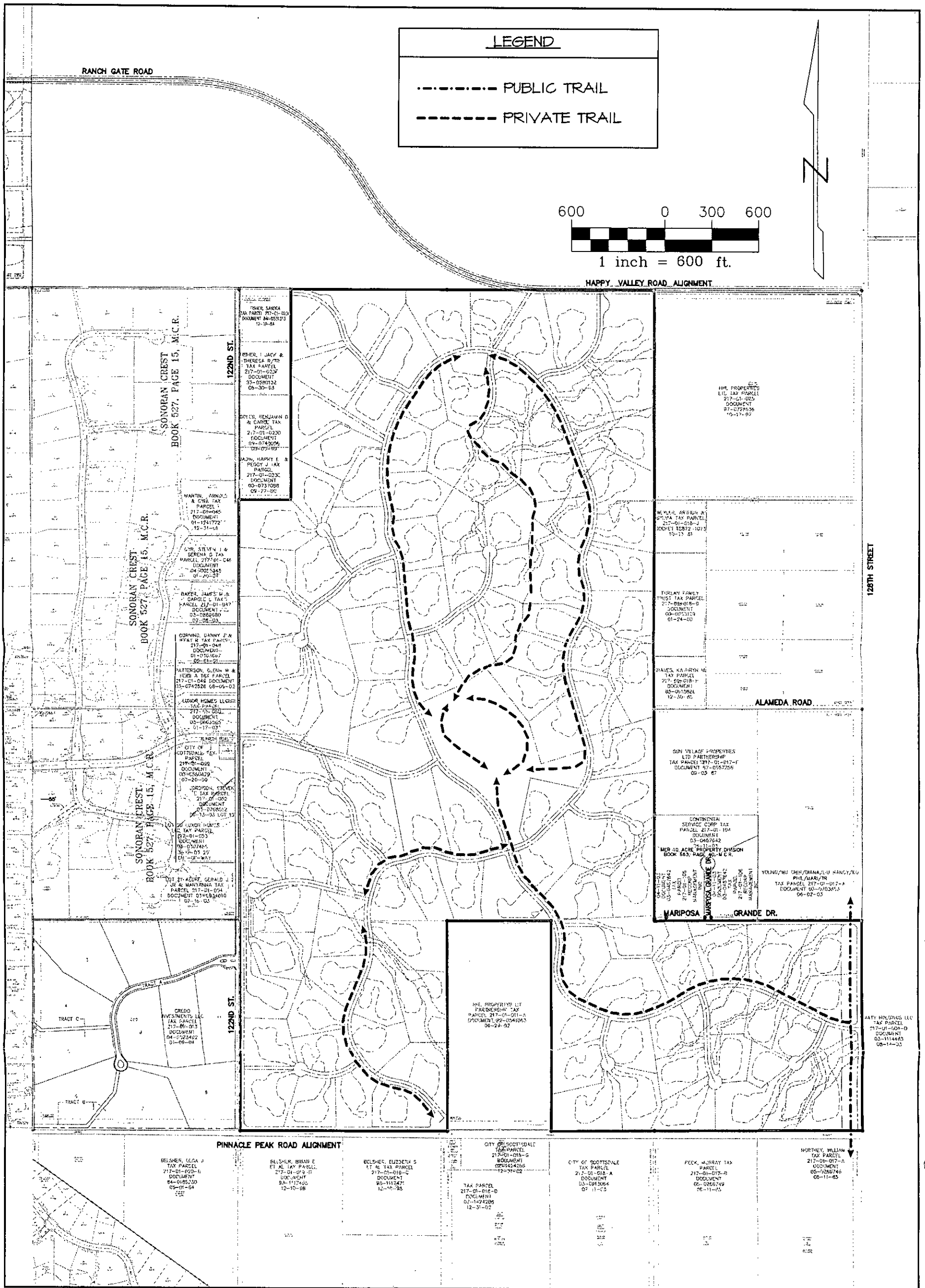



LEGEND

- Project Boundary
- - - New Roadway Access Improvements
- ▨ Project Site
- ☐ McDowell Sonoran Preserve

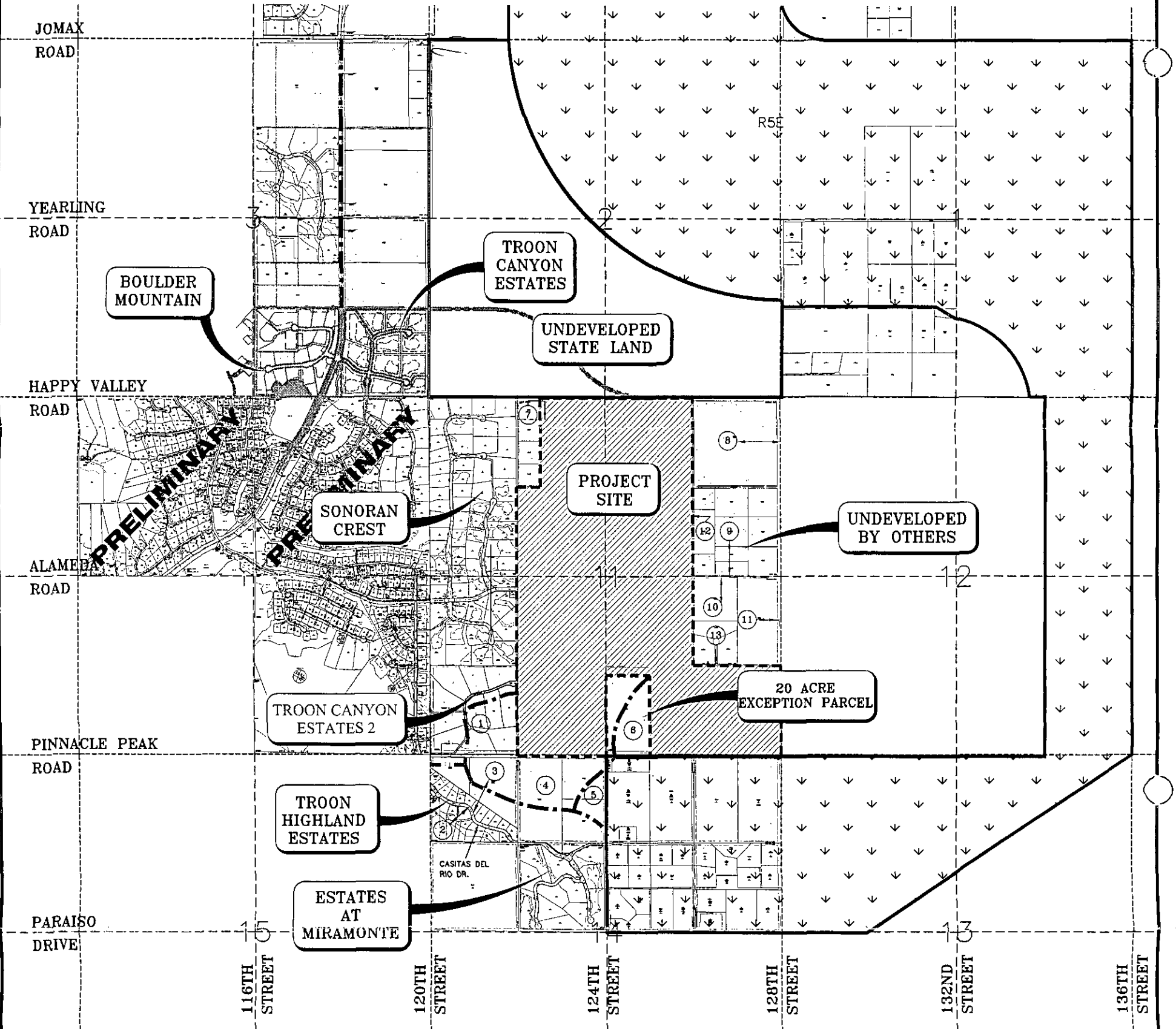

LEGEND

ABANDONMENT

REFER SECTION 6.2 OF REPORT

NOTE: ALL PUBLIC UTILITY & ROADWAY EASEMENTS PER BK.191 P. 626.

RANCH GATE ROAD

