

**CONCEPTUAL MASTER  
WASTEWATER SYSTEM REPORT  
FOR  
SERENO CANYON**

September 27, 2005  
WP# 042054.15

*Prepared for:*  
**Crown Community Development**  
Ms. Teri Frankiewicz  
3600 Thayer Court, Suite 100  
Aurora, Illinois 60504  
*Phone: (630) 851-5490*  
*Fax: (630) 898-0480*

*Prepared by:*  
**Wood, Patel & Associates, Inc.**  
2051 West Northern Avenue, Suite 100  
Phoenix, Arizona 85021  
*Phone: (602) 335-8500*  
*Fax: (602) 335-8580*

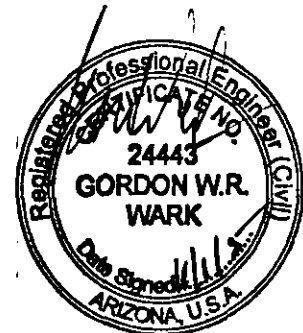

7424-05  
Eng Copy

CONCEPTUAL MASTER  
WASTEWATER SYSTEM REPORT  
FOR  
SERENO CANYON

Accepted for  
CITY OF SCOTTSDALE  
WATER RESOURCES DEPT  
9988 E SAN SALVADOR DR  
SCOTTSDALE, AZ 85258

By *Chris M. King*  
12.12.05

(SEE COMMENTS)

**WOOD/PATEL**

**City of Scottsdale**  
**Water Resources Department**  
**Basis of Design Review Comments**

Project: Sereno Canyon

Engineer: Wood/Patel

Date: January 27, 2006

Action: FYI – Attach to accepted reports

---

***Conceptual Master Potable Water System Report comments:***

1. If Ranch Gate Road is extended to 128<sup>th</sup>, utilities should be coordinated or roadway cross-section designed to allow for future utility installation.
2. Appendix D referenced on page 7 is not included in the report.
3. Recommend that as improvement plans are developed the developer meet with Water Resources to establish which items will be included in a credit agreement, applied toward over sizing, applicable for payback, or have been collected as in-lieu funding.
4. The Zone 12/13 Reservoir design report shows a 2914 hydraulic grade at Jomax and 118<sup>th</sup> with a greater flow than you assumed in the 16-inch pipe. Your report shows a hydraulic grade of 2974 in this area that is about 26 psi higher than the Zone 12/13 report. The new booster pump station (#145) will help to maintain onsite pressures.
5. Plate 4, Option 1 is to include a line from the cul-de-sac off pipe 390 to the northwest property line for a future connection to the adjacent property. A stub to the property line shall be included off node J-310. A water line will be installed along the 128<sup>th</sup> Street frontage to this project.

***Conceptual Master Wastewater System Report comments:***

6. Any downstream capacity issues associated with the ultimate build out will be addressed in the City's master plan as a system deficiency.
7. I don't follow why there are options 1 and 2 associated with the ultimate build out.
8. There are some issues with the conceptual pump scenarios that we can resolve with the design report for the lift station.

TABLE OF CONTENTS

1.0 INTRODUCTION ..... 1

    1.1 General Background and Project History ..... 1

    1.2 Scope of Master Wastewater System Report ..... 2

    1.3 Topographic Conditions ..... 2

2.0 DESIGN REQUIREMENTS ..... 3

    2.1 Population ..... 3

    2.2 Wastewater Flow Criteria ..... 3

    2.3 Wastewater System Criteria ..... 3

3.0 WASTEWATER FLOW CALCULATIONS ..... 4

    3.1 Pipe Sizing and Capacity Calculations ..... 4

4.0 GENERAL PLAN FOR THE ON-SITE WASTEWATER SYSTEM ..... 5

    4.1 Proposed On-Site Collection System for Option 1 ..... 5

    4.2 Proposed On-Site Collection System for Option 2 ..... 6

5.0 GENERAL PLAN FOR THE OFF-SITE WASTEWATER SYSTEM ..... 7

6.0 IMPACT OF FUTURE DEVELOPMENT ON PROPOSED SEWER INFRASTRUCTURE ..... 9

7.0 PAYBACK ELIGIBLE SEWER INFRASTRUCTURE ..... 11

8.0 CONCLUSIONS ..... 12



## APPENDICES

Appendix A	<u>Option 1</u> Table 1: Estimated Wastewater Flow Calculations Table 2: Estimated Pipe Capacities
Appendix B	<u>Option 2</u> Table 1: Estimated Wastewater Flow Calculations Table 2: Estimated Pipe Capacities
Appendix C	Sewage Pump Specifications Wet Well Calculations Force Main Calculations
Appendix D	Ultimate Buildout Condition in Area <u>Option 1</u> Table 1: Estimated Wastewater Flow Calculations – Ultimate Condition Table 2: Estimated Pipe Capacities – Ultimate Condition  <u>Option 2</u> Table 1: Estimated Wastewater Flow Calculations – Ultimate Condition Table 2: Estimated Pipe Capacities – Ultimate Condition  Ultimate Condition Sewage Pump Specifications Ultimate Condition Wet Well Calculations Ultimate Condition Force Main Calculations
Appendix E	References

## PLATES

Plate 1	Vicinity Map
Plate 1A	Phasing Map
Plate 2	Option 1: Conceptual Master Wastewater System
Plate 3	Option 2: Conceptual Master Wastewater System
Plate 4	Conceptual Master Wastewater System – Ultimate Condition

km

Y:\WP\Reports\Residential\042054 Sereno Canyon Conceptual Master Wastewater System Report.doc

## 1.0 INTRODUCTION

### 1.1 General Background and Project History

Sereno Canyon is located at the eastern edge of the City of Scottsdale, Maricopa County, Arizona, within a portion of Section 11, Township 4 North, Range 5 East. The site is currently an assemblage of undeveloped parcels bound to the west by the existing Sonoran Crest Development (122<sup>nd</sup> Street alignment), to the east by the 128<sup>th</sup> Street alignment, to the north by the Happy Valley Road alignment, and to the south by the McDowell Mountain Sonoran Preserve. Access to the development is planned from the west via the ½ -mile section roadway, Alameda Road. Plate 1 provides a vicinity map for the project and surrounding areas.

Sereno Canyon is a 330-acre residential custom lot sub-division, nestled at the northern base of the McDowell Mountains. The development includes approximately 122 lots ranging in size from 2 to 3 acres and an 11-acre community center with amenities such as jacuzzis, pools, water falls, and restaurant facilities. Interpretive trails and scattered pocket parks with water features will also be incorporated into the site plan. Plate 1A provides a phasing map for the project.

Crown Community Development has considered expanding Sereno Canyon to approximately 400 acres (146 lots) which would include the acquisition of the 40-acre parcel located at the northeast ¼ of Section 11, four (4) 2.5-acre parcels located at the northeast boundary of Sonoran Crest, and the 20-acre parcel located in the middle of the southern ½ portion of Section 11.

This *Conceptual Master Wastewater System Report for Sereno Canyon* is prepared as two options: Option 1 which represents the proposed 330-acre development, and Option 2 which includes the potential expansion (400-acre development with 146 lots). Land use information is provided by LVA Urban Design Studio L.L.C. (LVA), September 8, 2004.

## 1.2 Scope of Master Wastewater System Report

The intent of the *Conceptual Master Wastewater System Report for Sereno Canyon* is to identify the locations and preliminary sizes of the proposed sewer infrastructure required to provide sanitary service to the development for Options 1 and 2. The components of the sewer infrastructure discussed in this report include on-site and off-site sanitary sewer lines, a sewage pumping station and force main. This report also presents the estimated wastewater flow calculations and the estimated pipe capacities.

## 1.3 Topographic Conditions

Topography on the site slopes from the south to the northeast and northwest. Slopes vary, with the majority in the 3 to 5 percent range, and some minor portions being much steeper. Steeper slopes (5% and greater) are associated with the southern portion of the subject site. Gentler slopes (3% or less) are located within the northern portion of the subject site.

The majority of the subject site drains towards the northeast. The remainder of the site drains either westerly or northwesterly towards Alameda Road.

## 2.0 DESIGN REQUIREMENTS

The design criteria for Sereno Canyon development are consistent with the requirements set by the *City of Scottsdale Design Standards and Policy Manual*, *Arizona Department of Environmental Quality, Bulletin No. 11*, and *Arizona Administrative Code, Title 18, Chapter 9*. Please refer to Appendix C – *References* for these agency standards.

### 2.1 Population

The equivalent population is calculated based on the land use information for the development. It is computed as the ratio of the total wastewater flow for all land uses within a sub area to the average daily wastewater flow per person. The equivalent population inflow at each node of the proposed wastewater system is included with the peak flow calculations in Appendix A. A summary of the land use for Options 1 and 2 are provided in Table 2-1: *Sereno Canyon Land Use*.

Table 2-1: Sereno Canyon Land Use

Land Use	Option 1	Option 2
Residential Custom Lots	122	146
Community Center	10,000 Sq. ft	10,000 Sq. ft.

### 2.2 Wastewater Flow Criteria

The following is a summary of the major wastewater flow criteria utilized:

1. The average wastewater flow for a *residential* dwelling unit with a density less than or equal to 2 dwelling units per acre is **250** gallons per day (gpd), based on an average wastewater flow of **100** gpd/person, and a density of **2.5** persons/dwelling unit.
2. The average wastewater flow for *non-residential* land use (club house) is **0.9** gpd/sq. ft.
3. The peak hour flow is 4.0 times the average-day flow.

### 2.3 Wastewater System Criteria

1. Sewer lines are designed to provide mean velocities during full-flow conditions greater than 2.5 feet per second (fps) and less than 10.0 fps, based upon Manning's formula, with a roughness coefficient value of "n" equal to 0.013.
2. Sewer lines are designed to convey the peak flow such that ratio of depth of flow to pipe diameter (d/D ratio) is less than or equal to 0.65 for pipe sizes less than 12 inches.
3. Sewer lines 8 inches in diameter shall be designed at the minimum slope of 0.0052 ft/ft.



### 3.0 WASTEWATER FLOW CALCULATIONS

The average-day and peak wastewater flows are calculated using the criteria discussed in Section 2.0 of this report. Table 3.1 presents a summary of the average-day and peak-flow calculations for Options 1 and 2. Please refer to Appendix A – *Table 1: Estimated Peak Flow Calculations* for detailed flow calculations for Option 1, and Appendix B – *Table 1: Estimated Peak Flow Calculations* for detailed flow calculations for Option 2.

**Table 3-1: Average and Peak Flows for Options 1 and 2**

System	Average-Day Flow		Peak-Flow	
	(gpd)	(gpm)	(gpd)	(gpm)
Option 1	35,000	243	140,000	97.2
Option 2	41,000	28.5	164,000	113.8

#### 3.1 Pipe Sizing and Capacity Calculations

The pipe sizes are designed at the minimum slope using peak-flow pipe capacity and velocity calculations. During peak-flow conditions,  $d/D$  ratios are less than the minimum requirement of 0.65. During full-flow conditions, pipe velocities are within the design range of 2.5 to 10.0 fps. The actual pipe slopes and locations may vary upon final determination of subdivision layout. Deviations from the proposed system in this report shall ensure minimum design criteria are followed.

#### 4.0 GENERAL PLAN FOR THE ON-SITE WASTEWATER SYSTEM

The proposed on-site master wastewater system for Options 1 and 2 consist of 8-inch diameter gravity sewer lines. Details of these systems are presented below.

##### 4.1 Proposed On-Site Collection System for Option 1

Based on the topographic conditions, the proposed wastewater system for Option 1 consists of three (3) sewer systems and outfall locations. A description of these systems and the direction of the flow are as follows:

Sewer System 1: Alameda Road outfall (Node A to Node I) in the northwest direction

Sewer System 2: 128<sup>th</sup> Street outfall (Node J to Node Q) in the eastern direction

Sewer System 3: Happy Valley Road alignment outfall (Node R and Node V to Node AM) in the northern direction

Please refer to Plate 2 – *Option 1: Conceptual Master Wastewater System* for the pipe sizes and outfall locations. Sewer System 1 collects wastewater flow from Node A to Node I northwesterly and outfalls to the existing 8-inch gravity sewer along Alameda Road in Sonoran Crest. Sewer System 2 collects flows from Node J to Node Q easterly and outfalls to the proposed 8-inch gravity sewer along the 128<sup>th</sup> street alignment. System 3 collects flows from Node R and Node V to Node AM northerly and outfalls to the proposed 8-inch gravity sewer along the Happy Valley Road alignment. The proposed sewer systems consist of 8-inch diameter sewer lines to be constructed in the local collector roadways and sewer easements. Table 4.1 presents the average day and peak wastewater flows for the three (3) systems for Option 1. Please refer to Appendix A for detailed results.

**Table 4-1: Average and Peak Wastewater Flows for Option 1**

System	Average-Day Flow	Peak-Flow
	(gpd)	(gpd)
1	7,000	28,000
2	6,500	26,000
3	21,500	86,000
<b>Total</b>	<b>35,000</b>	<b>140,000</b>

#### 4.2 Proposed On-Site Collection System for Option 2

Based on the topographic conditions, the proposed wastewater system for Option 2 consists of three (3) different sewer systems and outfall locations. A description of these systems and the direction of the flow are as follows:

Sewer System 1: Alameda Road outfall (Node A to Node I) in the northwest direction

Sewer System 2: Southerly 128<sup>th</sup> Street outfall (Node J to Node Q in the eastern direction

Sewer System 3: Northerly 128<sup>th</sup> Street outfall (Node R and Node V to Node AM) in the northeast direction

Please refer to Plate 3 – *Option 2: Conceptual Master Wastewater System* for the pipe sizes and outfall locations. Sewer System 1 collects wastewater flow from Node A to Node I northwesterly and outfalls to the existing 8-inch gravity sewer along Alameda Road in Sonoran Crest. Sewer System 2 and System 3 collect wastewater flow from Node J to Node Q easterly and Node R and Node V to Node AM northeasterly, respectively, and outfall to the proposed 8-inch gravity sewer along the 128<sup>th</sup> street alignment. The proposed sewer systems consist of 8-inch diameter sewer lines to be constructed in the local collector roadways and sewer easements. Table 4.2 presents the average-day and peak wastewater flows for the three (3) systems for Option 2. Please refer to Appendix B for detailed results.

**Table 4-2: Average and Peak Wastewater Flows for Option 2**

System	Average-Day Flow	Peak-Flow
	(gpd)	(gpd)
1	7,000	28,000
2	8,250	33,000
3	25,750	103,000
<b>Total</b>	<b>41,000</b>	<b>164,000</b>

The 8-inch diameter on-site sewer lines proposed for Options 1 and 2 have adequate capacity to convey the estimated wastewater flow to the outfall locations. Please refer to *Table 2 - Estimated Pipe Capacities* in Appendices A & B for Options 1 and 2, respectively. It is anticipated that some lots may require individual grinder pumps with private force mains that would discharge into the proposed gravity sewer system.

## 5.0 GENERAL PLAN FOR THE OFF-SITE WASTEWATER SYSTEM

The off-site sewer infrastructure for development Options 1 and 2 consists of existing gravity sewer systems within the Sonoran Crest and Granite Ridge development, proposed 8-inch gravity sewer lines, a sewage pumping station and force-main along the Happy Valley Road alignment. An application has been submitted to State Land (App# 16-108746) for a public utility easement (PUE) on the north side of the proposed site along the Happy Valley Road alignment. The ultimate outfall for the wastewater flow generated by Sereno Canyon will be conveyed southerly via the existing 10-inch sewer line along Happy Valley Road to the City of Scottsdale Water Reclamation Facility. Plates 2 and 3 - *Options 1 and 2 Conceptual Master Wastewater System* identify the locations of the off-site sewer infrastructure.

For Option 1, flows directed in the north-west direction (sewer system 1) will outfall to the existing 8-inch gravity sewer system within Sonoran Crest. Flows directed in the eastern direction (sewer system 2) will be conveyed northerly via a proposed 8-inch gravity sewer line along 128<sup>th</sup> Street, from Node Q to a proposed sewage pumping station located near the intersection of 128<sup>th</sup> Street and the Happy Valley Road alignment. The proposed sewage pumping station will also collect flow from sewer system 3 via a proposed 8-inch gravity sewer line along the Happy Valley Road alignment.

Flows collected at the sewage pumping station would be pumped westerly through a proposed force-main along the Happy Valley Road alignment to the point of discharge into the existing 8-inch gravity sewer system within the Granite Ridge development. Please refer to Plate 2 for an illustration of the off-site sewer plan for Option 1.

The off-site sewer system for Option 2 is similar to Option 1, except for the proposed 8-inch gravity sewer line along the Happy Valley Road alignment. Option 2 allows flow from sewer system 3 to outfall to the proposed 8-inch gravity sewer along 128<sup>th</sup> Street. Please refer to Plate 3 for an illustration of the off-site sewer plan for Option 2.

The proposed sewage pumping station would be required to pump a design wastewater flow of 112,000 gpd (77.7 gpm) or 136,000 gpd (94.4 gpm) for Options 1 and 2 respectively. The sewage pump proposed for this application is a FLYGT M3127, 11HP, 460 Volt. One (1) pump is capable to pump the 132-gpm design flow at a total head of 74 feet. Two (2) pumps (duplex configuration) are required for operation of the sewage pumping station, in the event that one pump is out of service.

The proposed wet well is preliminary sized to be 6 feet in diameter by 17 feet deep. These dimensions result in a retention time of 13 minutes, which is within the required range of 10-30 minutes. Please refer to Appendix C for sewage pump specifications and details of the wet well design. A 4-inch DIP force main is proposed to convey the design wastewater flow of 132 gpm at a velocity of 3.38 feet per second (fps). For details of the force main calculations, please refer to Appendix C – *Force Main Calculations*.

The force main would be constructed of ductile iron pipe, and would be aligned along a graded and re-vegetated sewer easement to assure continual access to City maintenance crews. The preliminary design of the sewage pumping station and force main is conceptual, and is intended to be finalized with the actual design of the sewage pumping station and force main. The preliminary alignment of the force main and the location of the sewage pumping station are illustrated on Plate 2.

According to the sewer improvement plan for the Sonoran Crest sewer system, the 8-inch outfall line is adequate to intercept the 28,000 gpd peak wastewater flow generated by sewer system 1 for both Options 1 and 2, with a surplus capacity of approximately 1.07 MG. Please refer to the Sonoran Crest sewer improvement plan. The 8-inch offsite sewer line along Alameda Road is capable of conveying the above flow to the Happy Valley Road gravity sewer system with a surplus capacity of 0.33 MG. Please refer to Table 2 under Appendices A and B for the pipe capacity calculations.

The outfall system within Granite Ridge has adequate capacity to intercept flows from the force-main, with a surplus capacity of roughly 0.41 MG. Information regarding the existing sewer system in Granite Ridge is obtained from the *Engineering Report for Sewer Construction Facilities for the Granite Ridge Subdivision*, prepared by Arcadis, dated January 23, 2003. Please refer to Table 2 under Appendices A and B for the pipe capacity calculations for the Granite Ridge sewer system. Provisions will be made to accommodate odor control of the receiving manhole in the Granite Ridge Sewer System with the actual design of the force main. The 8-inch offsite sewer line within the Desert Ridge at Troon Canyon development is more than capable of conveying the above flow from Granite Ridge to Happy Valley Road with a surplus capacity of 0.22 MG. Please refer to Table 2 under Appendices A and B for the pipe capacity calculations.

**6.0 IMPACT OF FUTURE DEVELOPMENT ON PROPOSED SEWER INFRASTRUCTURE**

Based on topographic constraints, it is anticipated that the properties north and east of the proposed development would contribute flow to the proposed sewage pumping station. A preliminary analysis of the impact of the future developments on the sewage pumping station, force main and the offsite sewer system is included. The number of dwelling units is estimated, based on the City of Scottsdale’s Zoning Map and associated residential density of 0.31 dwelling units per acre. Please refer to Plate 4 for the properties impacting the proposed sewage pumping station.

The average day and peak hour wastewater flows are estimated based on the design criteria discussed in Section 3.0 of this report. The total estimated peak wastewater flow collected at the proposed sewage pumping station at the ultimate condition totals 435,000 gpd (302 gpm). Please refer to Table 6-1 below and Appendix D – *Table 1 – Estimated Flow Calculations – Ultimate Condition* for flow calculations at full build-out (ultimate) conditions for both Options 1 and 2.

**Table 6-1: Summary of Flow Calculations**

	ADF		PHF	
	(gpd)	(gpm)	(gpd)	(gpm)
<b>LS- Ultimate Condition</b>	108,750	75.5	435,000	302

The sewage pumping station would be designed to pump the design flow of 302 gpm at the ultimate condition. The sewage pump proposed for this application is a FLYGT N3127, 10HP, 460 Volt. One (1) pump is capable to pump the 375 gpm design flow at a total head of 59 feet. Two (2) pumps (duplex configuration) are required for operation of the sewage pumping station, in the event that one pump is out of service.

The proposed 6 ft diameter by 17 ft deep wet well is adequately sized for the ultimate condition and the alarms for the water level elevations need to be adjusted. These dimensions result in a retention time of 11 minutes, which is within the required range of 10 to 30 minutes. Please refer to Appendix D for sewage pump specifications and details of wet well design.

A second 4-inch DIP force main is required to convey the design wastewater flow of 375 gpm at a velocity of 4.7 fps. It is recommended that this second force main be installed along with the initially proposed force main to avoid repetition of trenching and restoration. For details of the force main calculations, please refer to Appendix D. The preliminary design of the sewage pumping station and

force main is conceptual, and is intended to be finalized with the actual design of the sewage pumping station and force main. The preliminary alignment of the force main and the location of the sewage pumping station are illustrated on Plate 4.

The 8-inch offsite sewer line within the Desert Crest at Troon Canyon development does not have sufficient capacity to convey the peak flow at the ultimate condition to the Happy Valley Road gravity sewer system. Please refer to Table 2 under Appendix D for the pipe capacity calculations for both Options 1 and 2. It is proposed to monitor flows as the area builds out and recalculate capacity of the existing system. In the event of inadequate capacity, additional parallel pipes may be installed by others.

## 7.0 PAYBACK ELIGIBLE SEWER INFRASTRUCTURE

The following proposed sewer infrastructure may be eligible for payback, over sizing and impact fee credit agreements with the city of Scottsdale and the adjacent benefiting properties.

- Sewage Pumping Station and its components
- Force Main
- 8-inch gravity sewer line along 128<sup>th</sup> Street and Happy Valley Road alignment

Sereno Canyon Community will explore every opportunity to utilize the funds available through oversizing agreements with the City of Scottsdale for oversizing the sewage pumping station, wet well, and electrical so that future pumps can be installed without any changes to the motor control center and standby generator and for installing the second 4-inch force main for future development. Further, the community will apply for impact fee credit and payback agreements. The community will also seek to utilize any "in lieu of" funds by adjacent properties that have been collected or are soon to be collected in future.

Sereno Canyon may also try to form a community facilities district to fund the construction and upsizing of sewer infrastructure.

A detailed report will be provided as required, identifying the options sought by Sereno Canyon and the sewer infrastructure eligible for any of the above alternatives.



## 8.0 CONCLUSIONS

Based on the analysis of the *Conceptual Master Wastewater System Report*, the following conclusions can be made:

1. The wastewater demand and system criteria are consistent with the criteria established with the *City of Scottsdale Design Standards and Policies Manual*, *Arizona Department of Environmental Quality (ADEQ) Bulletin No. 11*, and *Arizona Administrative Code, Title 18, Chapter 9*.
2. Wastewater service will be supplied to the development through 8-inch diameter sewer lines.
3. Average-day flow and peak-hour flow calculations are developed in order to provide preliminary sizing for the capacity of the sewer lines.
4. Pipe capacities are such that the d/D ratio is not to exceed 0.65 during peak-hour conditions for Sereno Canyon development.
5. The system is designed at the minimum slopes required to achieve a velocity under full-flow conditions between 2.5 fps and 10.0 fps.
6. The existing 8-inch sewer along Alameda Road in Sonoran Crest and has adequate capacity to accommodate peak flows generated by Sereno Canyon development in the northwest direction for both Options 1 and 2.
7. The existing 8-inch Granite Ridge gravity sewer system has adequate capacity to accommodate peak flows generated by Sereno Canyon development conveyed by the proposed force main for both Options 1 and 2.
8. Finally, the existing sewer collector system along Happy Valley Road is more than capable of accommodating the additional flows from Sereno Canyon development for both Options 1 and 2.
9. The existing sewer system within the Desert Ridge development does not have sufficient capacity to accommodate the additional flows from the adjacent properties to the proposed development under full build-out conditions. Additional parallel pipes may need to be installed at locations of inadequate capacity by others.
10. The sewer infrastructure that may be eligible for payback, impact fee credit and over sizing agreements is outlined in this report.

**APPENDIX A**

**Option 1**

**Table 1: Estimated Wastewater Flow Calculations**

**TABLE 1: WASTEWATER FLOW CALCULATIONS**

Project: Master Wastewater Plan for Sereno Canyon

Project Number: 042054.15

Location: City of Scottsdale

Project Engineer: Gordon Wark, P.E

Date: 31-Oct-05

References: City of Scottsdale Design Standards and Policies Manual

Site Plan for Sonoran Crest dated: 2/22/1999

Engineering Report for Construction of Sewer Facilities. Granite Ridge Subdivision, Arizona. Dated: January 23, 2002.

Sewer Quarter Section Map (46-55). City of Scottsdale, Arizona.

Site Plan for Desert Crest at Troon Ridge dated: 5/24/1991

Site Plan for The Estates at Desert Crest dated: 5/2/1991

UPSTREAM NODE	DOWNSTREAM NODE	PIPE DIA. (IN)	PIPE SLOPE (FT / FT)	RESIDENTIAL		NON-RESIDENTIAL		SUB-AREA ADF (GPD)	EQUIVALENT POPULATION	TOTAL ADF (GPD)	PEAKING FACTOR	PEAK FLOW (GPD)
				DWELLING UNITS < 2 DU/ACRE	ADF/UNIT	AREA (SQ.FT)	ADF/SQ.FT					
<b>Gravity Outfall to Alameda Road:</b>												
A	B	8	0.0052	2	250			500	5.0	500	4.00	2,000
C	B	8	0.0052	5	250			1,250	12.5	1,250	4.00	5,000
B	E	8	0.0052	7	250			1,750	17.5	3,500	4.00	14,000
D	E	8	0.0052	5	250			1,250	12.5	1,250	4.00	5,000
E	F	8	0.0052	1	250			250	2.5	5,000	4.00	20,000
G	F	8	0.0052	4	250			1,000	10.0	1,000	4.00	4,000
F	H	8	0.0052	4	250			1,000	10.0	7,000	4.00	28,000
H	I	8	0.0052							7,000	4.00	28,000
<b>Subtotal</b>				<b>28</b>	<b>250</b>			<b>7,000</b>	<b>70.0</b>	<b>7,000</b>		<b>28,000</b>
<b>Gravity Outfall to 128th Street Alignment:</b>												
J	K	8	0.0052	6	250			1,500	15.0	1,500	4.00	6,000
L	K	8	0.0052	3	250			750	7.5	750	4.00	3,000
K	N	8	0.0052	2	250			500	5.0	2,750	4.00	11,000
M	N	8	0.0052	4	250			1,000	10.0	1,000	4.00	4,000
N	P	8	0.0052	6	250			1,500	15.0	5,250	4.00	21,000
O	P	8	0.0052	5	250			1,250	12.5	1,250	4.00	5,000
P	Q	8	0.0052		0			0	0.0	6,500	4.00	26,000
<b>Subtotal</b>				<b>26</b>				<b>6,500</b>	<b>65.0</b>	<b>6,500</b>		<b>26,000</b>
<b>Gravity Outfall to the Happy Valley Road Alignment:</b>												
R	S	8	0.0052	3	250	5000	0.9	5,250	52.5	5,250	4.00	21,000
T	U	8	0.0052	5	250			1,250	12.5	1,250	4.00	5,000
U	S	8	0.0052	2	250			500	5.0	1,750	4.00	7,000
S	AE	8	0.0052	3	250			750	7.5	7,750	4.00	31,000
AB	AC	8	0.0052	5	250			1,250	12.5	1,250	4.00	5,000
AD	AC	8	0.0052	4	250			1,000	10.0	1,000	4.00	4,000
AC	AE	8	0.0052		0			0	0.0	2,250	4.00	9,000
AE	AF	8	0.0052	6	250			1,500	15.0	11,500	4.00	46,000
AG	AF	8	0.0052	5	250			1,250	12.5	1,250	4.00	5,000
AF	AH	8	0.0052	2	250			500	5.0	13,250	4.00	53,000
AI	AH	8	0.0052	5	250			1,250	12.5	1,250	4.00	5,000

UPSTREAM NODE	DOWNSTREAM NODE	PIPE DIA. (IN)	PIPE SLOPE (FT / FT)	RESIDENTIAL		NON-RESIDENTIAL		SUB-AREA ADF (GPD)	EQUIVALENT POPULATION	TOTAL ADF (GPD)	PEAKING FACTOR	PEAK FLOW (GPD)
				DWELLING UNITS < 2 DU/ACRE	ADF/UNIT	AREA (SQ.FT)	ADF/SQ.FT					
AH	AJ	8	0.0052	2	250			500	5.0	15,000	4.00	60,000
V	X	8	0.0052	2	250			500	5.0	500	4.00	2,000
W	X	8	0.0052	3	250			750	7.5	750	4.00	3,000
X	Z	8	0.0052	6	250			1,500	15.0	2,750	4.00	11,000
Y	Z	8	0.0052	3	250			750	7.5	750	4.00	3,000
Z	AA	8	0.0052	4	250			1,000	10.0	4,500	4.00	18,000
AA	AJ	8	0.0052	4	250			1,000	10.0	5,500	4.00	22,000
AJ	AK	8	0.0052	3	250			750	7.5	21,250	4.00	85,000
AK	AM	8	0.0052	1	250			250	2.5	21,500	4.00	86,000
AM	AN	8	0.0052							21,500	4.00	86,000
<b>Subtotal</b>				<b>68</b>		<b>5000</b>	<b>0.9</b>	<b>21,500</b>	<b>215.0</b>	<b>21,500</b>		<b>86,000</b>
<b>Total</b>				<b>122</b>				<b>35,000</b>	<b>350.0</b>	<b>35,000</b>		<b>140,000</b>
<b>Outfall to Offsite Gravity Sewer System in Sonoran Crest to Happy Valley Road</b>												
I	NODE 1	8	0.0200					7,000	70.0	7,000	4.00	28,000
NODE 1	NODE 2	8	0.0239							7,000	4.00	28,000
NODE 2	NODE 3	8	0.0196							7,000	4.00	28,000
NODE 4	NODE 5	8	0.0052							7,000	4.00	28,000
NODE 5 <sup>(1)</sup>	NODE 6	8	0.0052	42	250			10,500	105.0	17,500	4.00	70,000
NODE 6	NODE 7	8	0.0250							17,500	4.00	70,000
NODE 7	NODE 8	8	0.0281							17,500	4.00	70,000
NODE 8 <sup>(2)</sup>	NODE 9	8	0.0052	90	250			22,500	225.0	40,000	4.00	160,000
NODE 9 <sup>(2)</sup>	NODE 10	8	0.0052	19	250			4,750	47.5	44,750	4.00	179,000
NODE 10 <sup>(2)</sup>	NODE 11	8	0.0052	48	250			12,000	120.0	56,750	4.00	227,000
<b>Outfall to Granite Ridge Sewer System to Happy Valley Road</b>												
Q	AN	8	0.0052		0			0	0	6,500	4.00	26,000
AM	AN	8	0.0052		0					21,500	4.00	86,000
AN	AO		FM		0					28,000	4.00	112,000
AO <sup>(3)</sup>	AP	8	0.0052	16	250			4000	40	32,000	4.00	128,000
AP	AQ	8	0.0052		0					32,000	4.00	128,000
AQ <sup>(4)</sup>	AR	8	0.0052	3	250			750	8	32,750	4.00	131,000
AR1	AR2	8	0.0055		0					32,750	4.00	131,000
AR2 <sup>(4)</sup>	AR3	8	0.0064	1	250			250	3	33,000	4.00	132,000
AR3	AR4	8	0.0442		0					33,000	4.00	132,000
AR4 <sup>(4)</sup>	AR5	8	0.0055	7	250			1750	18	34,750	4.00	139,000
AR5 <sup>(4)</sup>	AR6	8	0.0055	1	250			250	3	35,000	4.00	140,000
AR6	AS	8	0.0056		0					35,000	4.00	140,000
AS <sup>(5)</sup>	AT	8	0.0129	6	250			1500	15	36,500	4.00	146,000
AT	AU	8	0.0126		0			0	0	36,500	4.00	146,000
AU <sup>(6)</sup>	AV	8	0.0208	12	250			3000	30	39,500	4.00	158,000
AV	AW	8	0.0420	10	250			2500	25	42,000	4.00	168,000
AW	AX	8	0.0449	5	250			1250	13	43,250	4.00	173,000
AX	AY	8	0.0060	3	250			750	8	44,000	4.00	176,000
AY	AZ	8	0.0227	1	250			250	3	44,250	4.00	177,000
AZ <sup>(7)</sup>	AA1	8	0.0296	15	250			3750	38	48,000	4.00	192,000
AA1 <sup>(8)</sup>	AA2	8	0.0238	32	250			8000	80	56,000	4.00	224,000

UPSTREAM NODE	DOWNSTREAM NODE	PIPE DIA. (IN)	PIPE SLOPE (FT / FT)	RESIDENTIAL		NON-RESIDENTIAL		SUB-AREA ADF (GPD)	EQUIVALENT POPULATION	TOTAL ADF (GPD)	PEAKING FACTOR	PEAK FLOW (GPD)
				DWELLING UNITS < 2 DU/ACRE	ADF/UNIT	AREA (SQ.FT)	ADF/SQ.FT					
AA2 <sup>(9)</sup>	AA3	8	0.0282	4	250			1000	10	57,000	4.00	228,000
AA3 <sup>(10)</sup>	AA4	8	0.0164	10	250			2500	25	59,500	4.00	238,000
AA4 <sup>(11)</sup>	AA5	8	0.0351	2	250			500	5	60,000	4.00	240,000
AA5 <sup>(12)</sup>	AA6	8	0.0228	14	250			3500	35	63,500	4.00	254,000
AA6	Ex. MH	8	0.0040		0					63,500	4.00	254,000

**Note:**

- 1) Contributing flows include flows generated from 42 lots in Sonoran Crest.
- 2) Contributing flows include flows generated from lots south of Alameda within Quarter Sections 44-56 (Section 15 T4N R5E), 44-57 (Section 14 T4N R5E), 45-56, 46-56 (Section 10 T4N R5E).
- 3) Contributing flows include flows generated from 16 lots in Sonoran Crest.
- 4) Contributing flows include flows generated by lots in Granite Ridge.
- 5) Contributing flows include flows generated from 6 lots in The Estates at Desert Crest.
- 6) Contributing flows include flows generated from lots in Desert Crest at Troon Ridge
- 7) Contributing flows include flows generated from 7 Desert Crest at Troon Ridge and 8 lots from other property
- 8) Contributing flows include flows generated from 20 lots in Desert Crest at Troon Ridge, 8 lots in the estates at Desert Crest and 4 lots from other property
- 9) Contributing flows include flows generated from lots in Desert Crest at Troon Ridge
- 10) Contributing flows include flows generated from lots in Desert Crest at Troon Ridge
- 11) Contributing flows include flows generated from lots in Desert Crest at Troon Ridge
- 12) Contributing flows include flows generated from lots in Desert Crest at Troon Ridge

**Table 2: Estimated Pipe Capacities**

TABLE 2: ESTIMATED PIPE CAPACITIES

Project: Master Wastewater Plan for Sereno Canyon  
 Location: Scottsdale, Arizona  
 Date: October 31, 2005

Project Number: 042054.15  
 Project Engineer: Gordon Wark, P.E

FROM NODE	TO NODE	PIPE SIZE (IN)	PEAK FLOW (GPD)	PIPE SLOPE (FT/FT)	FULL FLOW VELOCITY, V <sub>0</sub> (FPS)	PARTIAL FLOW VELOCITY, V <sub>1</sub> (FPS)	PIPE CAPACITY (GPD)	SURPLUS CAPACITY (GPD)	d/D
<b>Gravity Outfall to Alameda Road</b>									
A	B	8	2,000	0.0052	2.5	0.6	564,339	562,339	0.04
C	B	8	5,000	0.0052	2.5	0.8	564,339	559,339	0.07
B	E	8	14,000	0.0052	2.5	1.1	564,339	550,339	0.11
D	E	8	5,000	0.0052	2.5	0.8	564,339	559,339	0.07
E	F	8	20,000	0.0052	2.5	1.2	564,339	544,339	0.13
G	F	8	4,000	0.0052	2.5	0.7	564,339	560,339	0.06
F	H	8	28,000	0.0052	2.5	1.3	564,339	536,339	0.15
H	I	8	28,000	0.0052	2.5	1.3	564,339	536,339	0.15
<b>Gravity Outfall to 128th Street Alignment</b>									
J	K	8	6,000	0.0052	2.5	0.8	564,339	558,339	0.07
L	K	8	3,000	0.0052	2.5	0.7	564,339	561,339	0.05
K	N	8	11,000	0.0052	2.5	1.0	564,339	553,339	0.10
M	N	8	4,000	0.0052	2.5	0.7	564,339	560,339	0.06
N	P	8	21,000	0.0052	2.5	1.2	564,339	543,339	0.13
O	P	8	5,000	0.0052	2.5	0.8	564,339	559,339	0.07
P	Q	8	26,000	0.0052	2.5	1.3	564,339	538,339	0.15
<b>Gravity Outfall to the Happy Valley Road Alignment</b>									
R	S	8	21,000	0.0052	2.5	1.2	564,339	543,339	0.13
T	U	8	5,000	0.0052	2.5	0.8	564,339	559,339	0.07
U	S	8	7,000	0.0052	2.5	0.9	564,339	557,339	0.08
S	AE	8	31,000	0.0052	2.5	1.3	564,339	533,339	0.16
AB	AC	8	5,000	0.0052	2.5	0.8	564,339	559,339	0.07
AD	AC	8	4,000	0.0052	2.5	0.7	564,339	560,339	0.06
AC	AE	8	9,000	0.0052	2.5	0.9	564,339	555,339	0.09
AE	AF	8	46,000	0.0052	2.5	1.5	564,339	518,339	0.19
AG	AF	8	5,000	0.0052	2.5	0.8	564,339	559,339	0.07
AF	AH	8	53,000	0.0052	2.5	1.6	564,339	511,339	0.21
AI	AH	8	5,000	0.0052	2.5	0.8	564,339	559,339	0.07
AH	AJ	8	60,000	0.0052	2.5	1.6	564,339	504,339	0.22
V	X	8	2,000	0.0052	2.5	0.6	564,339	562,339	0.04
W	X	8	3,000	0.0052	2.5	0.7	564,339	561,339	0.05
X	Z	8	11,000	0.0052	2.5	1.0	564,339	553,339	0.10
Y	Z	8	3,000	0.0052	2.5	0.7	564,339	561,339	0.05
Z	AA	8	18,000	0.0052	2.5	1.1	564,339	546,339	0.12
AA	AJ	8	22,000	0.0052	2.5	1.2	564,339	542,339	0.13
AJ	AK	8	85,000	0.0052	2.5	1.8	564,339	479,339	0.26
AK	AM	8	86,000	0.0052	2.5	1.8	564,339	478,339	0.26
AM	AN	8	86,000	0.0052	2.5	1.8	564,339	478,339	0.26
<b>Outfall to Offsite Gravity Sewer System in Sonoran Crest to Happy Valley Road</b>									
I	NODE 1	8	28,000	0.0200	4.9	2.1	1,106,761	1,078,761	0.11
NODE 1	NODE 2	8	28,000	0.0239	5.4	2.2	1,209,867	1,181,867	0.11
NODE 2	NODE 3	8	28,000	0.0196	4.9	2.1	1,095,637	1,067,637	0.11
NODE 4	NODE 5	8	28,000	0.0052	2.5	1.3	564,339	536,339	0.15
NODE 5 (1)	NODE 6	8	70,000	0.0052	2.5	1.7	564,339	494,339	0.24
NODE 6	NODE 7	8	70,000	0.0250	5.5	3.0	1,237,396	1,167,396	0.16
NODE 7	NODE 8	8	70,000	0.0281	5.8	3.1	1,311,873	1,241,873	0.16
NODE 8 (2)	NODE 9	8	160,000	0.0052	2.5	2.2	564,339	404,339	0.36
NODE 9 (2)	NODE 10	8	179,000	0.0052	2.5	2.2	564,339	385,339	0.39
NODE 10 (2)	NODE 11	8	227,000	0.0052	2.5	2.4	564,339	337,339	0.44
<b>Outfall to Granite Ridge Sewer System to Happy Valley Road</b>									
Q	AN	8	26,000	0.0052	2.5	1.3	564,339	538,339	0.15
AM	AN	8	86,000	0.0052	2.5	1.8	564,339	478,339	0.26



FROM NODE	TO NODE	PIPE SIZE (IN)	PEAK FLOW (GPD)	PIPE SLOPE (FT/FT)	FULL FLOW VELOCITY, V <sub>0</sub> (FPS)	PARTIAL FLOW VELOCITY, V <sub>1</sub> (FPS)	PIPE CAPACITY (GPD)	SURPLUS CAPACITY (GPD)	d/D
AN	AO	0	112,000	FM					
AO (3)	AP	8	128,000	0.0052	2.5	2.0	564,339	436,339	0.32
AP	AQ	8	128,000	0.0052	2.5	2.0	564,339	436,339	0.32
AQ (4)	AR	8	131,000	0.0052	2.5	2.0	564,339	433,339	0.33
AR1	AR2	8	131,000	0.0055	2.6	2.1	580,390	449,390	0.32
AR2 (4)	AR3	8	132,000	0.0064	2.8	2.2	626,078	494,078	0.31
AR3	AR4	8	132,000	0.0442	7.3	4.4	1,644,573	1,512,573	0.19
AR4 (4)	AR5	8	139,000	0.0055	2.6	2.1	580,390	441,390	0.33
AR5 (4)	AR6	8	140,000	0.0055	2.6	2.1	580,390	440,390	0.33
AR6	AS	8	140,000	0.0056	2.6	2.1	585,643	445,643	0.33
AS (5)	AT	8	146,000	0.0129	3.9	2.9	888,860	742,860	0.27
AT	AU	8	146,000	0.0126	3.9	2.9	878,464	732,464	0.28
AU (6)	AV	8	158,000	0.0208	5.0	3.5	1,128,679	970,679	0.25
AV	AW	8	168,000	0.0420	7.1	4.6	1,603,849	1,435,849	0.22
AW	AX	8	173,000	0.0449	7.4	4.8	1,658,295	1,485,295	0.22
AX	AY	8	176,000	0.0060	2.7	2.3	606,198	430,198	0.37
AY	AZ	8	177,000	0.0227	5.2	3.8	1,179,103	1,002,103	0.26
AZ (7)	AA1	8	192,000	0.0296	6.0	4.2	1,346,433	1,154,433	0.26
AA1 (8)	AA2	8	224,000	0.0238	5.4	4.1	1,207,333	983,333	0.29
AA2 (9)	AA3	8	228,000	0.0282	5.8	4.4	1,314,206	1,086,206	0.28
AA3 (10)	AA4	8	238,000	0.0164	4.4	3.6	1,002,214	764,214	0.33
AA4 (11)	AA5	8	240,000	0.0351	6.5	4.8	1,466,197	1,226,197	0.27
AA5 (12)	AA6	8	254,000	0.0226	5.2	4.2	1,176,503	922,503	0.31
AA6	Ex. MH	8	254,000	0.0040	2.2	2.2	494,958	240,958	0.51

**APPENDIX B**

**Option 2**

**Table 1: Estimated Wastewater Flow Calculations**

**TABLE 1: WASTEWATER FLOW CALCULATIONS**

Project: Master Wastewater Plan for Sereno Canyon  
 Location: City of Scottsdale  
 Date: 31-Oct-05  
 References: City of Scottsdale Design Standards and Policies Manual  
 Site Plan for Sonoran Crest dated: 2/22/1999  
 Engineering Report for Construction of Sewer Facilities. Granite Ridge Subdivision, Arizona. Dated: January 23, 2002.  
 Sewer Quarter Section Maps. City of Scottsdale, Arizona.  
 Site Plan for Desert Crest at Troon Ridge dated: 5/24/1991  
 Site Plan for The Estates at Desert Crest dated: 5/2/1991

Project Number: 042054.15  
 Project Engineer: Gordon Wark, P.E

UPSTREAM NODE	DOWNSTREAM NODE	PIPE DIA. (IN)	PIPE SLOPE (FT / FT)	RESIDENTIAL		NON-RESIDENTIAL		SUB-AREA ADF (GPD)	EQUIVALENT POPULATION	TOTAL ADF (GPD)	TOTAL EQUIVALENT POPULATION	PEAKING FACTOR	PEAK FLOW (GPD)
				DWELLING UNITS < 2 DU/ACRE	ADF/UNIT	AREA (SQ.FT)	ADF/SQ.FT						
<b>Gravity Outfall to the West</b>													
A	B	8	0.0052	2	250			500	5	500	5	4.00	2,000
C	B	8	0.0052	5	250			1,250	13	1,250	18	4.00	5,000
B	E	8	0.0052	7	250			1,750	18	3,500	35	4.00	14,000
D	E	8	0.0052	5	250			1,250	13	1,250	48	4.00	5,000
E	F	8	0.0052	2	250			500	5	5,250	53	4.00	21,000
G	F	8	0.0052	4	250			1,000	10	1,000	63	4.00	4,000
F	H	8	0.0052	3	250			750	8	7,000	70	4.00	28,000
H	I	8	0.0052		0			0	0	7,000	70	4.00	28,000
<b>Subtotal</b>				<b>28</b>	<b>250</b>			<b>7,000</b>		<b>7,000</b>	<b>70</b>		<b>28,000</b>
<b>Gravity Outfall to the East at Node Q</b>													
J	J1	8	0.0052	1	250			250	3	250	3	4.00	1,000
A1	J1	8	0.0052	6	250			1,500	15	1,500	15	4.00	6,000
J1	K	8	0.0052	5	250			1,250	13	3,000	30	4.00	12,000
A2	K	8	0.0052	1	250			250	3	250	3	4.00	1,000
L	K	8	0.0052	4	250			1,000	10	1,000	43	4.00	4,000
K	N	8	0.0052	1	250			250	3	4,500	45	4.00	18,000
M	N	8	0.0052	5	250			1,250	13	1,250	58	4.00	5,000
N	P	8	0.0052	5	250			1,250	13	7,000	13	4.00	28,000
O	P	8	0.0052	5	250			1,250	13	1,250	13	5.00	6,250
P	Q	8	0.0052	0	0			0	0	8,250	70	4.00	33,000
<b>Subtotal</b>				<b>33</b>				<b>8,250</b>		<b>8,250</b>	<b>70</b>		<b>33,000</b>
<b>Gravity Outfall to the East at Node AM</b>													
R	S	8	0.0052	3	250	5000	0.9	5,250	53	5,250	53	4.00	21,000
T	U	8	0.0052	6	250			1,500	15	1,500	68	4.00	6,000
U	S	8	0.0052	1	250			250	3	1,750	3	4.00	7,000
S	AE	8	0.0052	4	250			1,000	10	8,000	80	4.00	32,000
AB	AC	8	0.0052	5	250			1,250	13	1,250	13	4.00	5,000
AD	AC	8	0.0052	5	250			1,250	13	1,250	25	4.00	5,000
AC	AE	8	0.0052	0	0			0	0	2,500	0	4.00	10,000
AE	AF	8	0.0052	5	250			1,250	13	11,750	38	4.00	47,000
AG	AF	8	0.0052	8	250			2,000	20	2,000	138	4.00	8,000

UPSTREAM NODE	DOWNSTREAM NODE	PIPE DIA. (IN)	PIPE SLOPE (FT / FT)	DWELLING UNITS < 2 DU/ACRE	ADF/UNIT	AREA (SQ.FT)	ADF/SQ.FT	SUB-AREA ADF (GPD)	EQUIVALENT POPULATION	TOTAL ADF (GPD)	TOTAL EQUIVALENT POPULATION	PEAKING FACTOR	PEAK FLOW (GPD)
AF	AH	8	0.0052	3	250			750	8	14,500	93	5.00	72,500
AI	AH	8	0.0052	5	250			1,250	13	1,250	13	4.00	5,000
AH	AJ	8	0.0052	1	250			250	3	16,000	3	4.00	64,000
V	X	8	0.0052	2	250			500	5	500	20	4.00	2,000
W	X	8	0.0052	3	250			750	8	750	28	4.00	3,000
X	Z	8	0.0052	5	250			1,250	13	2,500	13	4.00	10,000
Y	Z	8	0.0052	3	250			750	8	750	48	4.00	3,000
Z	AA	8	0.0052	4	250			1,000	10	4,250	10	4.00	17,000
AA	AJ	8	0.0052	6	250			1,500	15	5,750	73	4.00	23,000
AJ	AK	8	0.0052	3	250			750	8	22,500	80	4.00	90,000
AK	AA2	8	0.0052	5	250			1,250	13	23,750	93	4.00	95,000
AA1	AA2	8	0.0052	8	250			2,000	20	2,000	158	4.00	8,000
AA2	AM	8	0.0052	0	250			0	0	25,750	238	4.00	103,000
<b>Subtotal</b>				<b>85</b>		<b>5,000</b>	<b>0.9</b>	<b>25,750</b>		<b>25,750</b>	<b>238</b>		<b>103,000</b>
<b>Total</b>				<b>146</b>				<b>41,000</b>		<b>41,000</b>	<b>378</b>		<b>164,000</b>

**Gravity Outfall to the Alameda Sewer Line in Sonoran Crest to Happy Valley Road**

I	NODE 1	8	0.0200							7,000	70	4	28,000
NODE 1	NODE 2	8	0.0239							7,000	70	4	28,000
NODE 2	NODE 3	8	0.0196							7,000	70	4	28,000
NODE 4	NODE 5	8	0.0052							7,000	70	4	28,000
NODE 5 <sup>(1)</sup>	NODE 6	8	0.0052	42	250			10,500	105	17,500	175	4	70,000
NODE 6	NODE 7	8	0.0250						0	17,500	175	4	70,000
NODE 7	NODE 8	8	0.0281						0	17,500	175	4	70,000
NODE 8 <sup>(2)</sup>	NODE 9	8	0.0052	90	250			22,500	225	40,000	175	4	160,000
NODE 9 <sup>(2)</sup>	NODE 10	8	0.0052	19	250			4,750	47.5	44,750	175	4	179,000
NODE 10 <sup>(2)</sup>	NODE 11	8	0.0052	48	250			12,000	120	56,750	175	4	227,000

**Outfall to the Granite Ridge Sewer System to Happy Valley Road**

Q	AM	8	0.0052		0			0	0	8,250	70	4	33,000
AM	AN	8	0.0052							34,000	308	4	136,000
AN	A0		FM							34,000	308	4	136,000
A0 <sup>(3)</sup>	AP	8	0.0052	16	250			4,000	40	38,000	348	4	152,000
AP	AQ	8	0.0052					0	0	38,000	348	4	152,000
AQ <sup>(4)</sup>	AR	8	0.0052	3	250			750	7.5	38,750	355	4	155,000
AR1	AR2	8	0.0055					0	0	38,750	355	4	155,000
AR2 <sup>(4)</sup>	AR3	8	0.0064	1	250			250	2.5	39,000	358	4	156,000
AR3	AR4	8	0.0442					0	0	39,000	358	4	156,000
AR4 <sup>(4)</sup>	AR5	8	0.0055	7	250			1,750	17.5	40,750	375	4	163,000
AR5 <sup>(4)</sup>	AR6	8	0.0055	1	250			250	2.5	41,000	378	4	164,000
AR6	AS	8	0.0056					0	0	41,000	378	4	164,000
AS <sup>(5)</sup>	AT	8	0.0129	6	250			1,500	15	42,500	393	4	170,000
AT	AU	8	0.0126					0	0	42,500	393	4	170,000
AU <sup>(6)</sup>	AV	8	0.0208	12	250			3,000	30	45,500	423	4	182,000
AV	AW	8	0.0420	10	250			2,500	25	48,000	448	4	192,000
AW	AX	8	0.0449	5	250			1,250	12.5	49,250	460	4	197,000
AX	AY	8	0.0060	3	250			750	7.5	50,000	468	4	200,000
AY	AZ	8	0.0227	1	250			250	2.5	50,250	470	4	201,000
AZ <sup>(7)</sup>	AA1	8	0.0296	15	250			3,750	37.5	54,000	508	4	216,000
AA1 <sup>(6)</sup>	AA2	8	0.0238	32	250			8,000	80	62,000	588	4	248,000
AA2 <sup>(6)</sup>	AA3	8	0.0282	4	250			1,000	10	63,000	598	4	252,000

UPSTREAM NODE	DOWNSTREAM NODE	PIPE DIA. (IN)	PIPE SLOPE (FT / FT)	DWELLING UNITS < 2 DU/ACRE	ADF/UNIT	AREA (SQ.FT)	ADF/SQ.FT	SUB-AREA ADF (GPD)	EQUIVALENT POPULATION	TOTAL ADF (GPD)	TOTAL EQUIVALENT POPULATION	PEAKING FACTOR	PEAK FLOW (GPD)
AA3 <sup>(10)</sup>	AA4	8	0.0164	10	250			2,500	25	65,500	623	4	262,000
AA4 <sup>(11)</sup>	AA5	8	0.0351	2	250			500	5	66,000	628	4	264,000
AA5 <sup>(12)</sup>	AA6	8	0.0226	14	250			3,500	35	69,500	663	4	278,000
AA6	Ex. MH	8	0.0040		-			0	0	69,500	663	4	278,000

Note:

- 1) Contributing flows include flows generated from 42 lots in Sonoran Crest.
- 2) Contributing flows include flows generated from lots south of Alameda within Quarter Sections 44-56 (Section 15 T4N R5E), 44-57 (Section 14 T4N R5E), 45-56, 46-56 (Section 10 T4N R5E).
- 3) Contributing flows include flows generated from 16 lots in Sonoran Crest.
- 4) Contributing flows include flows generated by lots in Granite Ridge.
- 5) Contributing flows include flows generated from 6 lots in The Estates at Desert Crest.
- 6) Contributing flows include flows generated from lots in Desert Crest at Troon Ridge
- 7) Contributing flows include flows generated from 7 Desert Crest at Troon Ridge and 8 lots from other property
- 8) Contributing flows include flows generated from 20 lots in Desert Crest at Troon Ridge, 8 lots in the estates at Desert Crest and 4 lots from other property
- 9) Contributing flows include flows generated from lots in Desert Crest at Troon Ridge
- 10) Contributing flows include flows generated from lots in Desert Crest at Troon Ridge
- 11) Contributing flows include flows generated from lots in Desert Crest at Troon Ridge
- 12) Contributing flows include flows generated from lots in Desert Crest at Troon Ridge

**Table 2: Estimated Pipe Capacities**

**TABLE 2: ESTIMATED PIPE CAPACITIES**

Project: Master Wastewater Plan for Sereno Canyon  
 Location: Scottsdale, Arizona  
 Date: 31-Oct-05

Project Number: 042054.15  
 Project Engineer: Gordon Wark, P.E

FROM NODE	TO NODE	PIPE SIZE (IN)	PEAK FLOW (GPD)	PIPE SLOPE (FT/FT)	FULL FLOW VELOCITY, V <sub>0</sub> (FPS)	PARTIAL FLOW VELOCITY, V <sub>1</sub> (FPS)	PIPE CAPACITY (GPD)	SURPLUS CAPACITY (GPD)	d/D
<b>Gravity Outfall to the West</b>									
A	B	8	2,000	0.0052	2.5	0.6	564,339	562,339	0.04
C	B	8	5,000	0.0052	2.5	0.9	564,339	559,339	0.08
B	E	8	14,000	0.0052	2.5	0.9	564,339	550,339	0.08
D	E	8	5,000	0.0052	2.5	0.8	564,339	559,339	0.07
E	F	8	21,000	0.0052	2.5	1.2	564,339	543,339	0.13
G	F	8	4,000	0.0052	2.5	0.7	564,339	560,339	0.06
F	H	8	28,000	0.0052	2.5	1.3	564,339	536,339	0.15
H	I	8	28,000	0.0052	2.5	1.3	564,339	536,339	0.15
<b>Gravity Outfall to the East at Node Q</b>									
J	J1	8	1,000	0.0052	2.5	0.5	564,339	563,339	0.03
A1	J1	8	6,000	0.0052	2.5	0.8	564,339	558,339	0.07
J1	K	8	12,000	0.0052	2.5	1.0	564,339	552,339	0.10
A2	K	8	1,000	0.0052	2.5	0.5	564,339	563,339	0.03
L	K	8	4,000	0.0052	2.5	0.7	564,339	560,339	0.06
K	N	8	18,000	0.0052	2.5	1.1	564,339	546,339	0.12
M	N	8	5,000	0.0052	2.5	0.8	564,339	559,339	0.07
N	P	8	28,000	0.0052	2.5	1.3	564,339	536,339	0.15
O	P	8	6,250	0.0052	2.5	0.8	564,339	558,089	0.07
P	Q	8	33,000	0.0052	2.5	1.4	564,339	531,339	0.16
<b>Gravity Outfall to the East at Node AM</b>									
R	S	8	21,000	0.0052	2.5	1.2	564,339	543,339	0.13
T	U	8	6,000	0.0052	2.5	0.8	564,339	558,339	0.07
U	S	8	7,000	0.0052	2.5	0.9	564,339	557,339	0.08
S	AE	8	32,000	0.0052	2.5	1.3	564,339	532,339	0.16
AB	AC	8	5,000	0.0052	2.5	0.8	564,339	559,339	0.07
AD	AC	8	5,000	0.0052	2.5	0.8	564,339	559,339	0.07
AC	AE	8	10,000	0.0052	2.5	1.0	564,339	554,339	0.09
AE	AF	8	47,000	0.0052	2.5	1.5	564,339	517,339	0.20
AG	AF	8	8,000	0.0052	2.5	0.9	564,339	556,339	0.08
AF	AH	8	72,500	0.0052	2.5	1.7	564,339	491,839	0.24
AI	AH	8	5,000	0.0052	2.5	0.8	564,339	559,339	0.07
AH	AJ	8	64,000	0.0052	2.5	1.7	564,339	500,339	0.23
V	X	8	2,000	0.0052	2.5	0.6	564,339	562,339	0.04
W	X	8	3,000	0.0052	2.5	0.7	564,339	561,339	0.05
X	Z	8	10,000	0.0052	2.5	1.0	564,339	554,339	0.10
Y	Z	8	3,000	0.0052	2.5	0.7	564,339	561,339	0.05
Z	AA	8	17,000	0.0052	2.5	1.1	564,339	547,339	0.12
AA	AJ	8	23,000	0.0052	2.5	1.2	564,339	541,339	0.14
AJ	AK	8	90,000	0.0052	2.5	1.8	564,339	474,339	0.27
AK	AA2	8	95,000	0.0052	2.5	1.9	564,339	469,339	0.28
AA1	AA2	8	8,000	0.0052	2.5	0.9	564,339	556,339	0.08
AA2	AM	8	103,000	0.0052	2.5	2	564,339	461,339	0.29
<b>Gravity Outfall to the Alameda Sewer Line in Sonoran Crest to Happy Valley Road</b>									
J	NODE 1	8	28,000	0.0200	4.9	2.1	1,106,761	1,078,761	0.11
NODE 1	NODE 2	8	28,000	0.0239	5.4	2.2	1,209,867	1,181,867	0.11
NODE 2	NODE 3	8	28,000	0.0196	4.9	2.1	1,095,637	1,067,637	0.11
NODE 4	NODE 5	8	28,000	0.0052	2.5	1.3	564,339	536,339	0.15
NODE 5(1)	NODE 6	8	70,000	0.0052	2.5	1.7	564,339	494,339	0.24
NODE 6	NODE 7	8	70,000	0.0250	5.5	3.0	1,237,396	1,167,396	0.16
NODE 7	NODE 8	8	70,000	0.0281	5.8	3.1	1,311,873	1,241,873	0.16



FROM NODE	TO NODE	PIPE SIZE (IN)	PEAK FLOW (GPD)	PIPE SLOPE (FT/FT)	FULL FLOW VELOCITY, V <sub>0</sub> (FPS)	PARTIAL FLOW VELOCITY, V <sub>1</sub> (FPS)	PIPE CAPACITY (GPD)	SURPLUS CAPACITY (GPD)	d/D
NODE 8 (2)	NODE 9	8	160,000	0.0052	2.5	2.2	564,339	404,339	0.36
NODE 9 (2)	NODE 10	8	179,000	0.0052	2.5	2.2	564,339	385,339	0.39
NODE 10 (2)	NODE 11	8	227,000	0.0052	2.5	2.4	564,339	337,339	0.44
<b>Outfall to the Granite Ridge Sewer System to Happy Valley Road</b>									
Q	AM	8	33,000	0.0052	2.5	1.4	564,339	531,339	0.16
AM	AN	8	136,000	0.0052	2.5	2.1	564,339	428,339	0.33
AN	AO	0	136,000	FM					
AO (3)	AP	8	152,000	0.0052	2.5	2.1	564,339	412,339	0.35
AP	AQ	8	152,000	0.0052	2.5	2.1	564,339	412,339	0.35
AQ (4)	AR	8	155,000	0.0052	2.5	2.1	564,339	409,339	0.36
AR1	AR2	8	155,000	0.0055	2.6	2.2	580,390	425,390	0.35
AR2 (4)	AR3	8	156,000	0.0064	2.8	2.3	626,078	470,078	0.34
AR3	AR4	8	156,000	0.0442	7.3	4.6	1,645,318	1,489,318	0.21
AR4 (4)	AR5	8	163,000	0.0055	2.6	2.2	580,390	417,390	0.36
AR5 (4)	AR6	8	164,000	0.0055	2.6	2.2	580,390	416,390	0.36
AR6	AS	8	164,000	0.0056	2.6	2.2	585,643	421,643	0.36
AS (5)	AT	8	170,000	0.0129	3.9	3.0	888,860	718,860	0.30
AT	AU	8	170,000	0.0126	3.9	3.0	878,464	708,464	0.30
AU (6)	AV	8	182,000	0.0208	5.0	3.7	1,128,679	946,679	0.27
AV	AW	8	192,000	0.0420	7.1	4.8	1,603,849	1,411,849	0.23
AW	AX	8	197,000	0.0449	7.4	4.9	1,658,295	1,461,295	0.23
AX	AY	8	200,000	0.0060	2.7	2.4	606,198	406,198	0.40
AY	AZ	8	201,000	0.0227	5.2	3.9	1,179,103	978,103	0.28
AZ (7)	AA1	8	216,000	0.0296	6.0	4.4	1,346,433	1,130,433	0.27
AA1 (8)	AA2	8	248,000	0.0238	5.4	4.2	1,207,333	959,333	0.31
AA2 (9)	AA3	8	252,000	0.0282	5.8	4.5	1,314,206	1,062,206	0.30
AA3 (10)	AA4	8	262,000	0.0164	4.4	3.7	1,002,214	740,214	0.35
AA4 (11)	AA5	8	264,000	0.0351	6.5	4.9	1,466,197	1,202,197	0.29
AA5 (12)	AA6	8	278,000	0.0226	5.2	4.3	1,176,503	898,503	0.33
AA6	Ex. MH	8	278,000	0.0040	2.2	2.3	494,958	216,958	0.54

**APPENDIX C**

**Sewage Pump Specifications**

Duty Analysis - Performance curves

Project: MDMBB-InterIm-01  
Created by: Network Administrator

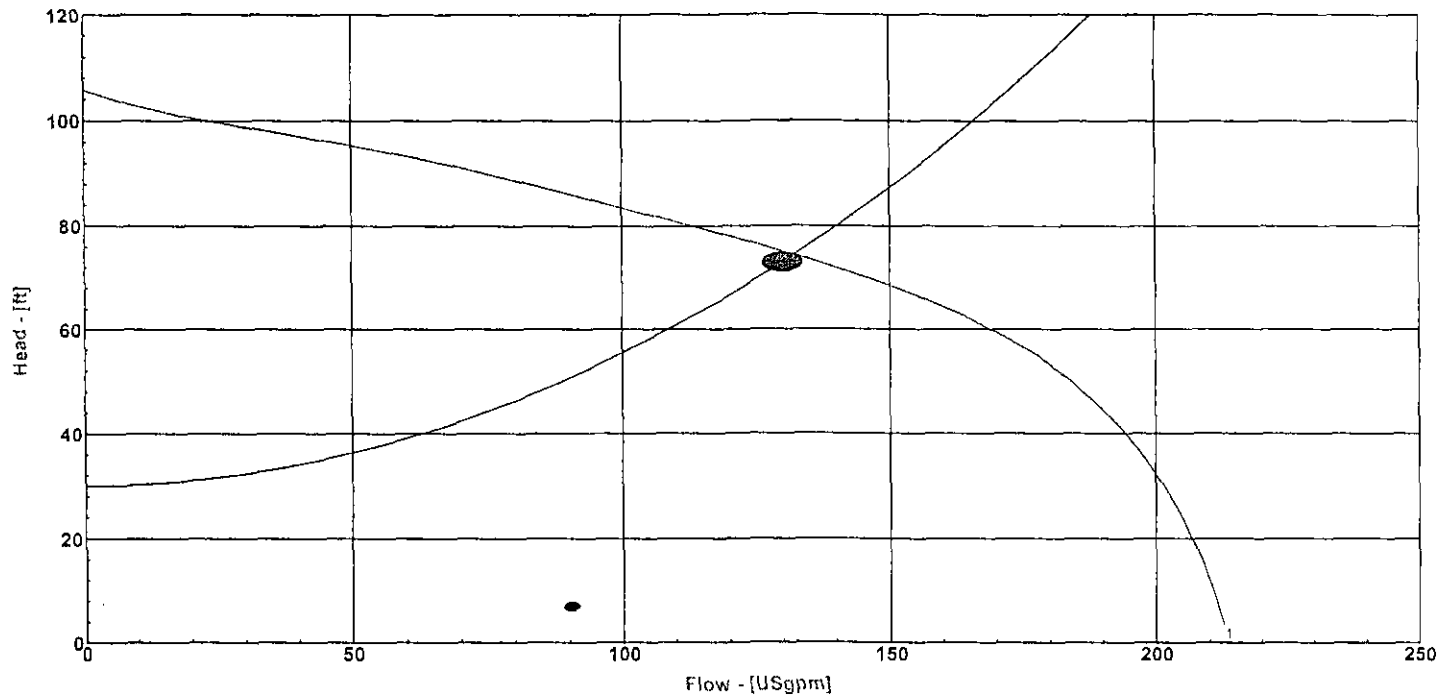

Performance

1. MF 3127 - 63-216-00-5210 11 hp 159 mm



# PERFORMANCE CURVE

PRODUCT  
**MP3127.170**

TYPE  
**LT**

DATE  
**2005-09-26**

PROJECT  
**MDMBB-Interim-01**

CURVE NO  
**63-216-00-5210**

ISSUE  
**1**

POWER FACTOR 0.91	1/1-LOAD	3/4-LOAD	1/2-LOAD	RATED POWER ..... 11 hp	IMPELLER DIAMETER 159 mm			
	EFFICIENCY 84.0 %	83.5 %	80.5 %		STARTING CURRENT ... 113 A	MOTOR # 21-11-2AL	STATOR 38D	REV 11
MOTOR DATA	---	---	---	RATED CURRENT ... 13 A	FREQ. 60 Hz	PHASES 3	VOLTAGE 460 V	POLES 2
COMMENTS	INLET/OUTLET - / 2 inch		RATED SPEED ..... 3510 rpm	TOT.MOM.OF INERTIA ... ---	GEARTYPE		RATIO	
	IMP. THROUGHLET ---				---		---	

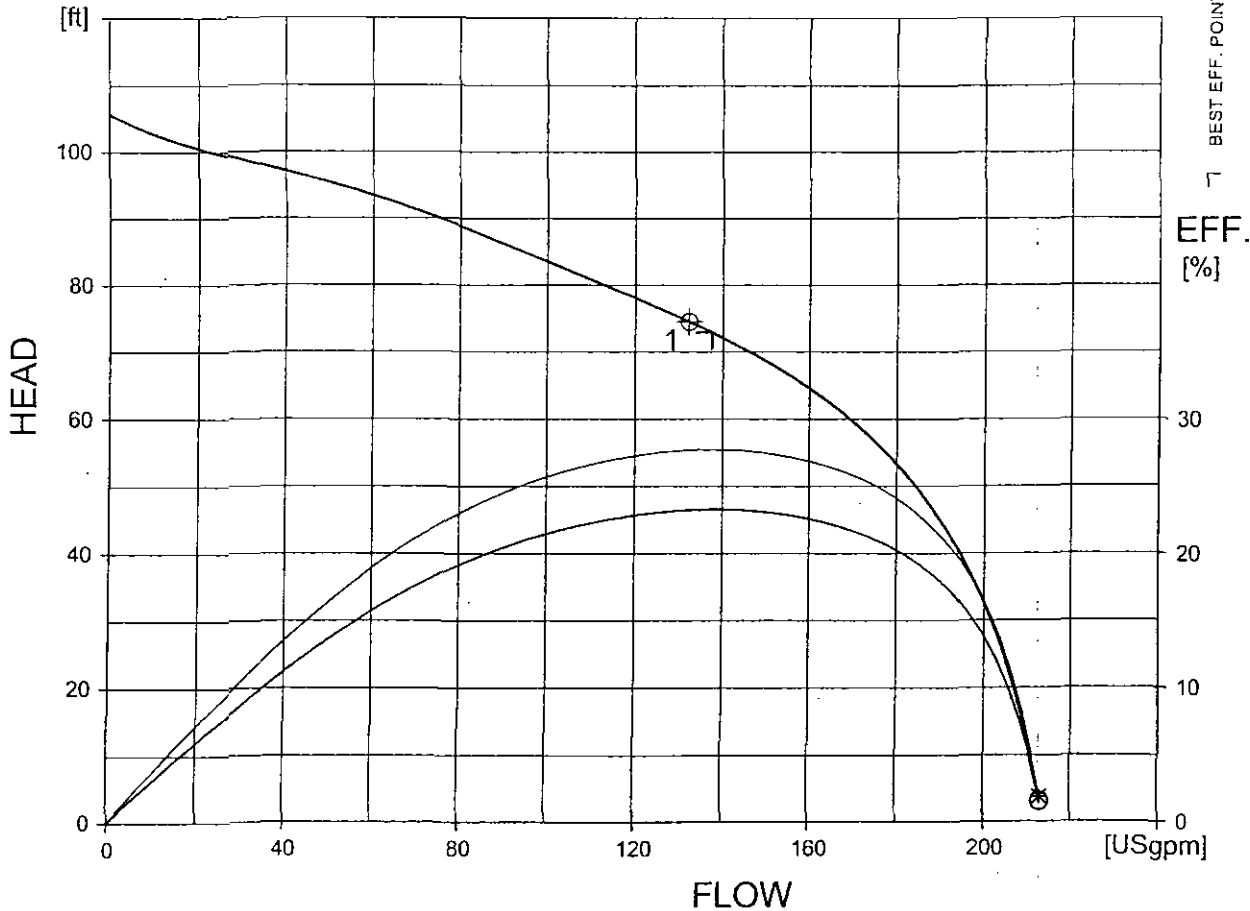
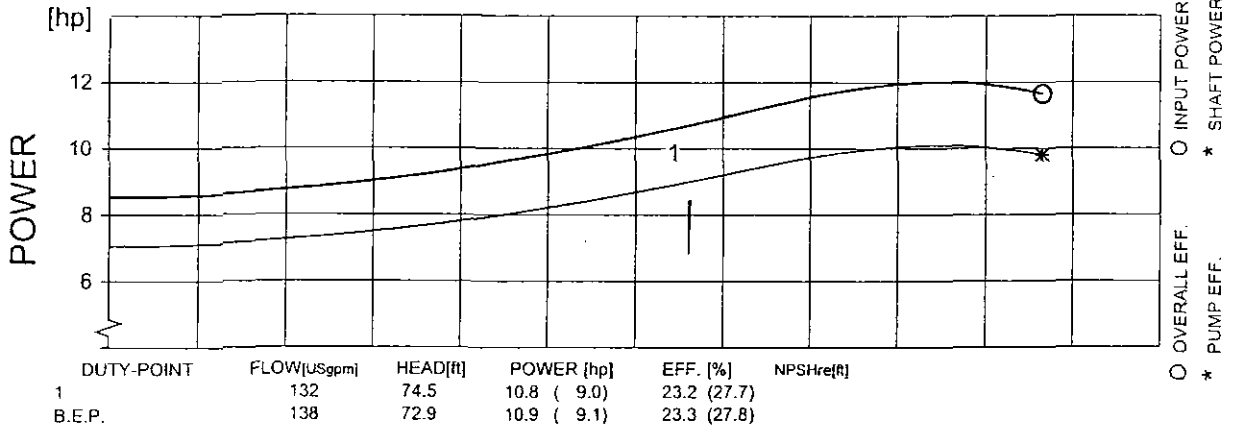

FLYPS2.19.6.0 (20040913)



**CURVE**

Performance with clear water and ambient temp 40 °C

# M-3127

## Submersible Wastewater Grinder Pump

SECTION	PAGE
9	3
SUPERSEDES	ISSUED
6/90	6/94

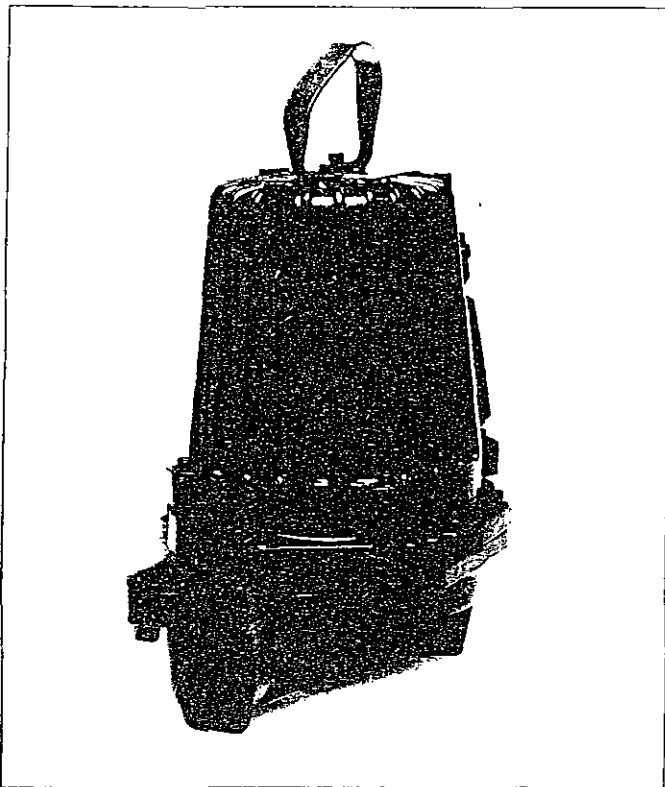

durable sealing performance and maximum resistance to abrasion and thermal shock.

- F Oil Casing:** Oil filled housing for lubricating and cooling mechanical seal units provides an additional leakage barrier.
- G Pump Volute:** Volute incorporates replaceable hardened cutting ring at the inlet.
- H Impeller:** Multi-vane semi-open impeller with replaceable cutting head.

### Grinder Pump:

7.5 HP 3Ø and 5.0 HP 1Ø

Available in the following configurations:

**Type MP** - Wet pit installation. Pump lowered via guide bars to automatically connect to a permanently mounted discharge connection.

**Type MF** - Portable, free standing. For pipeline connection in restricted sumps.

### Design Features:

**A Junction chamber:** In the cable entry, water sealing is functionally separated from strain relief, (no epoxy). Grommet's controlled compression assures leakproof sealing. Beyond the cable entry, a rubber lead-through compressed by a gland provides a secondary seal between junction chamber and motor housing.

**B Motor:** Squirrel cage induction motor NEMA type B. Class F (155°C) insulated stator winding. Capable of starting up to 15 times/hour (max.).

Cooling: Motor casings with integral cooling ribs for maximum heat dissipation.

**C Pump/motor shaft:** Common pump/motor shaft and compact seal design permit short overhang minimizing shaft deflection.

**D Shaft mounting:** Robust maintenance free design, comprising pre-greased ball bearings.

**E Shaft sealing:** Two independent mechanical face seals assembled in tandem provide reliable and

### Application:

The M-3127 is designed for residential and commercial wastewater.

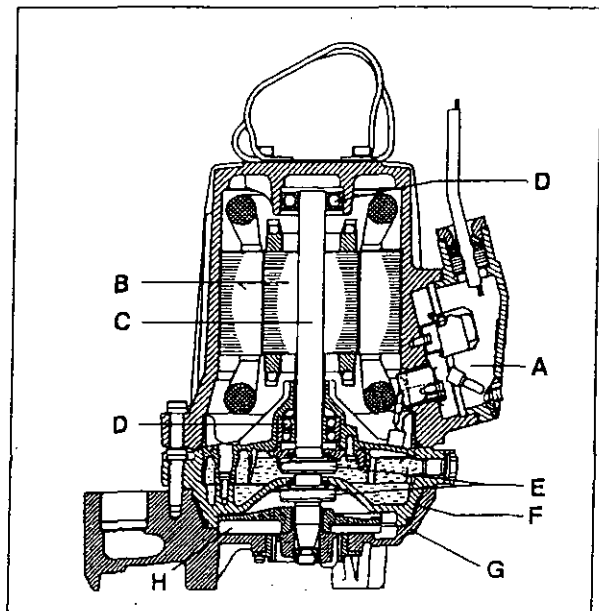

# M-3127

## Family of Performance Curves

SECTION      PAGE

**9**                      **5**

SUPERSEDES      ISSUED

2/88                      6/94

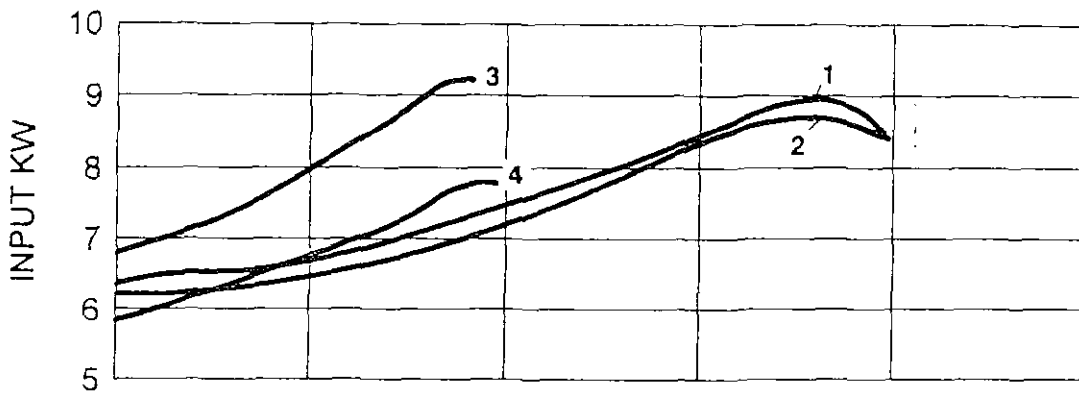

**NOTE:**

Family of performance curves are for pre-selection only.  
See individual curves in this section for final selection

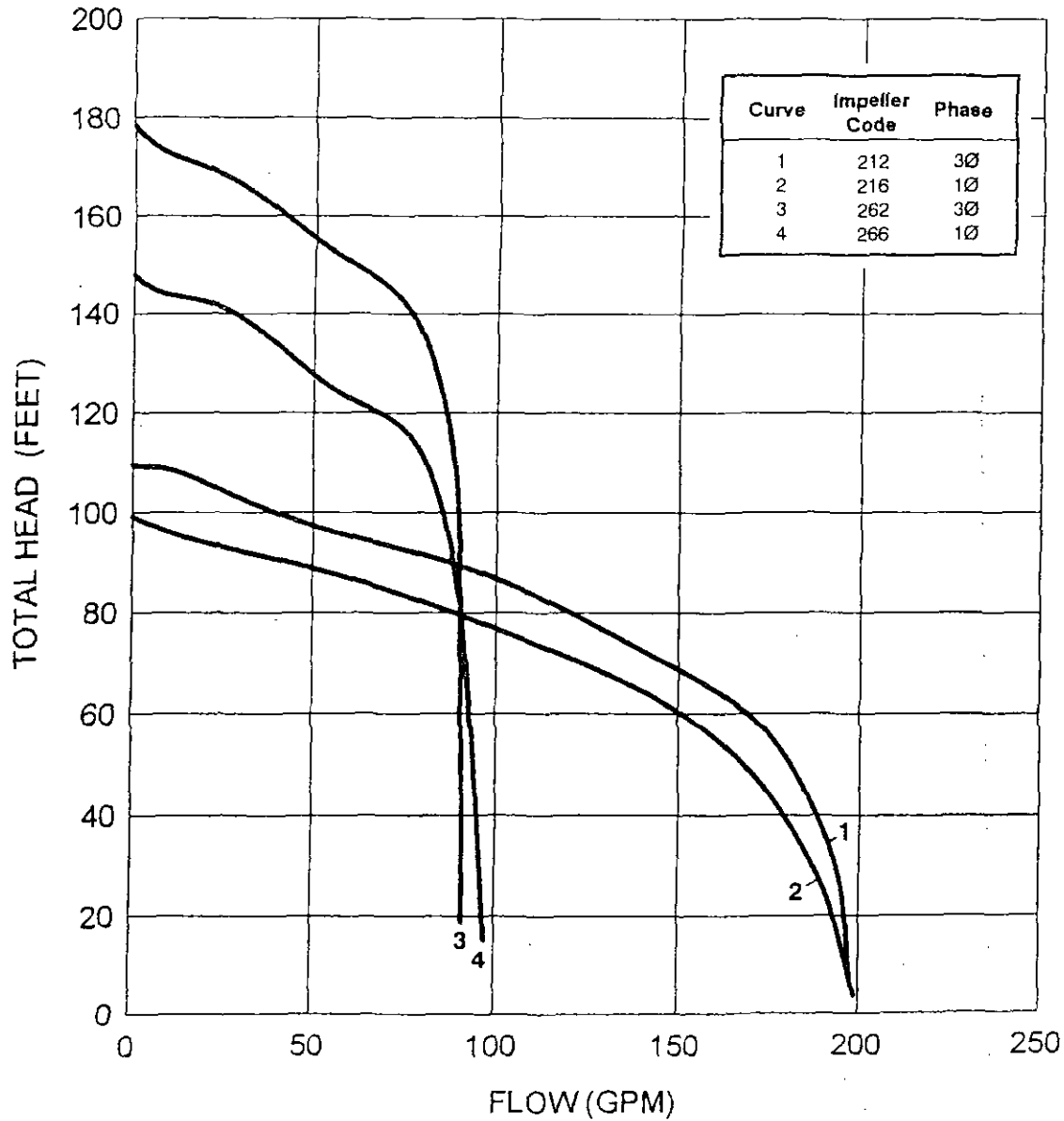

CONFIG.

MP/MF

PHASE

VANES

1

--

# M-3127 216 Impeller

SECTION

PAGE

9

7

SUPERSEDES

ISSUED

2/88

6/94

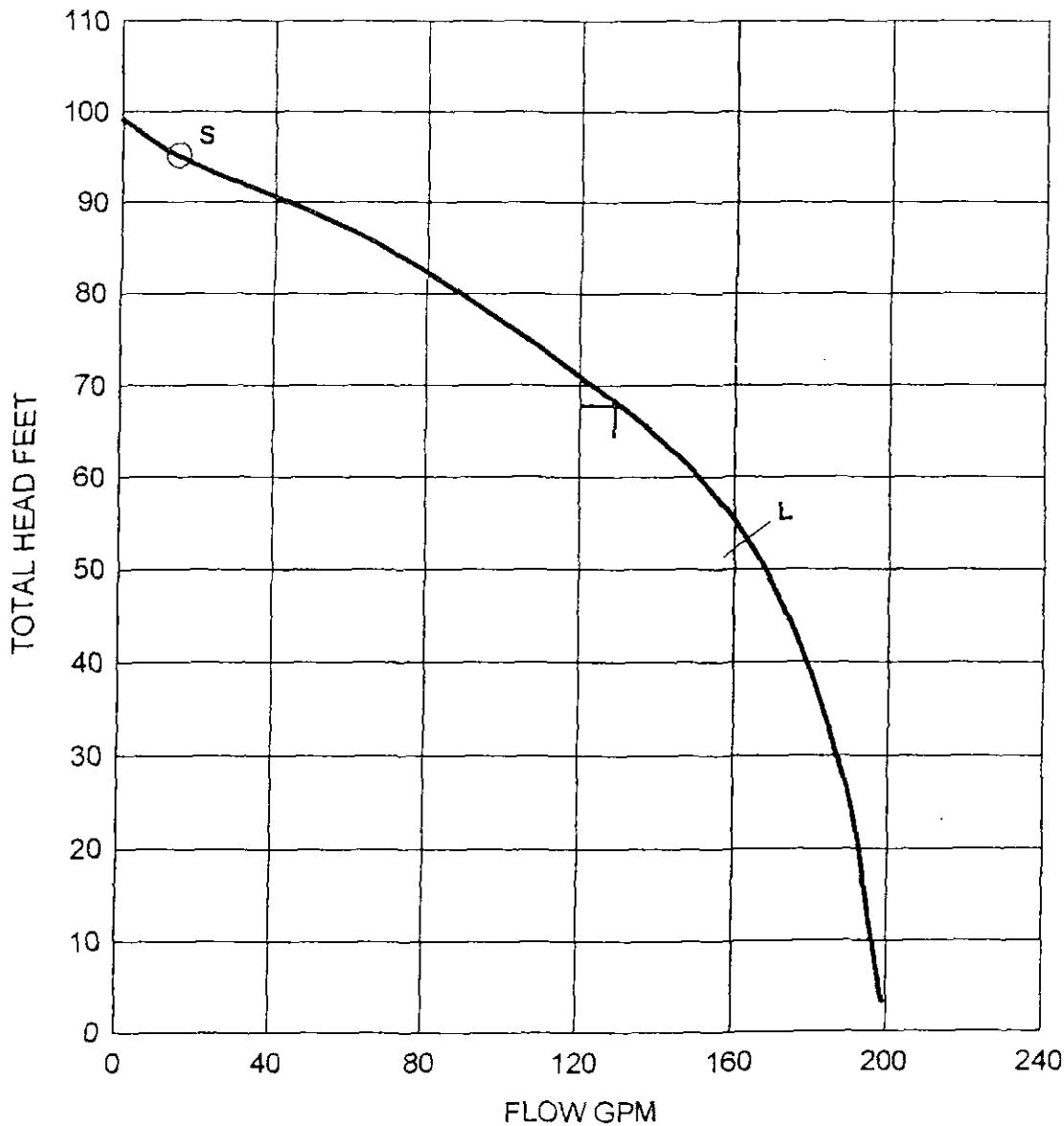
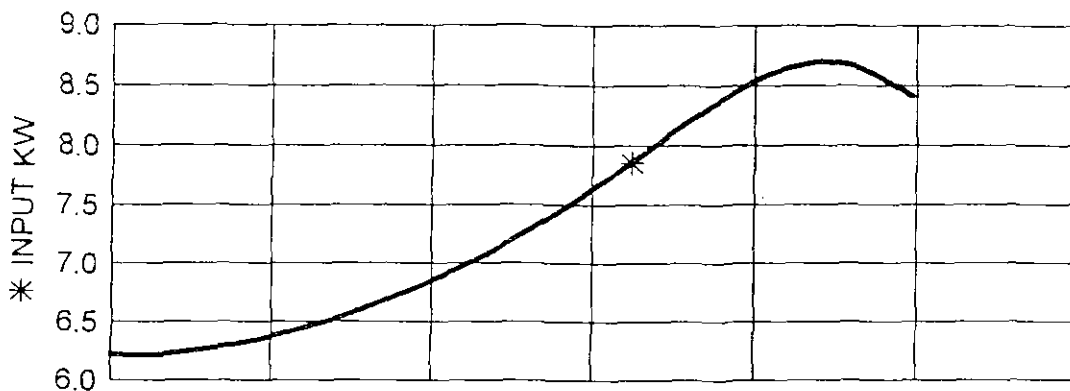

L = Limited to intermittent duty  
 S = Risk of sedimentation at velocity  
 below 2 ft/sec.



CONFIG.

MP/MF

PHASE

VANES

1

--

# M-3127 266 Impeller

SECTION

9

SUPERSEDES

2/88

PAGE

9

ISSUED

6/94

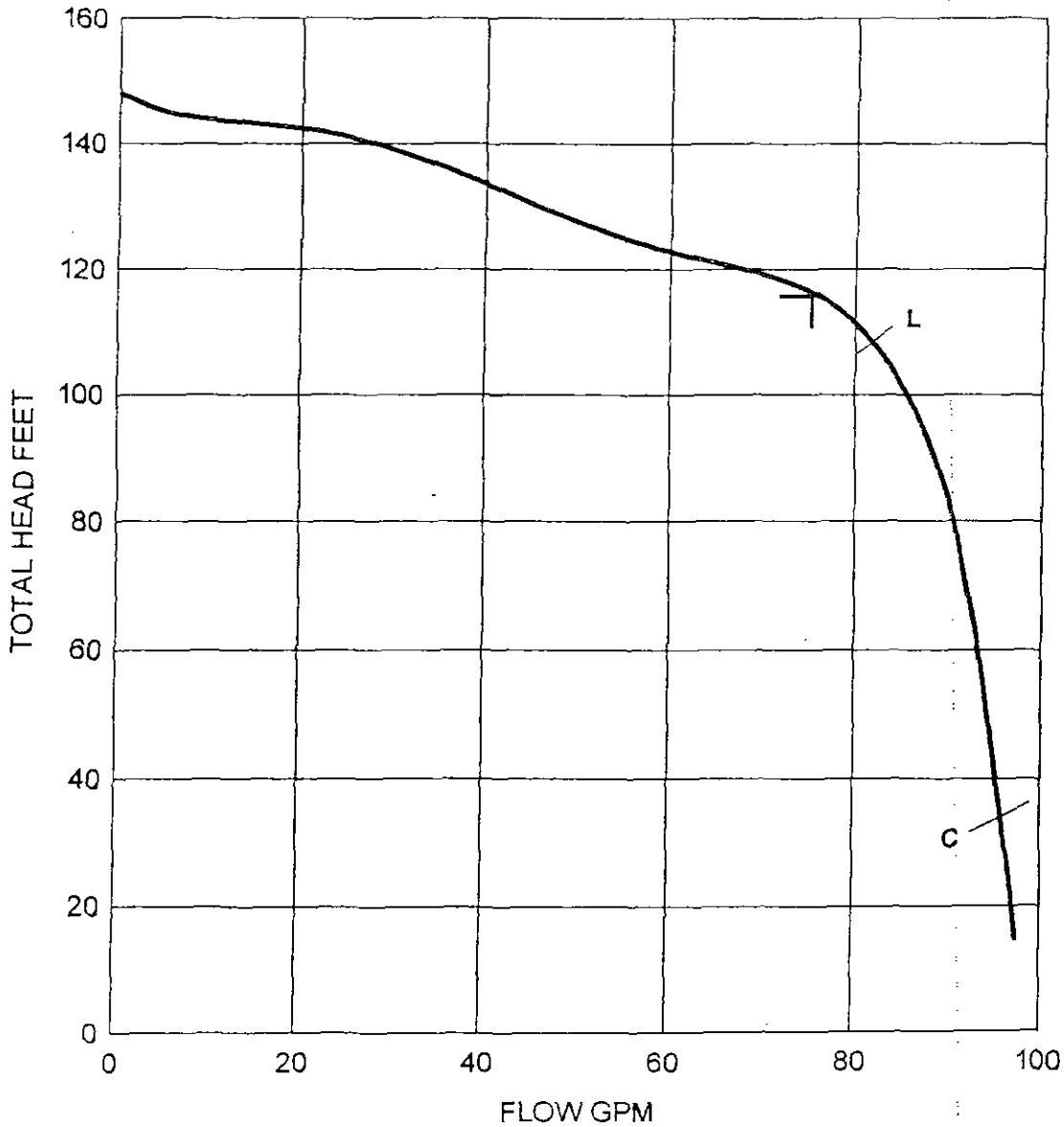
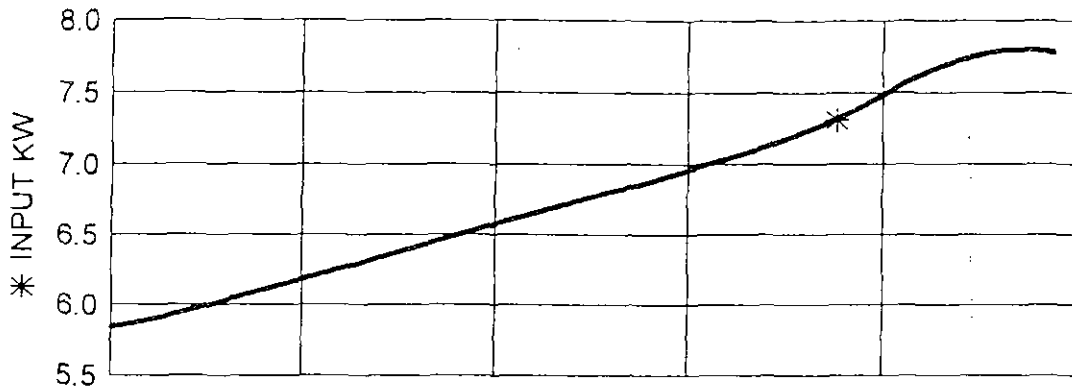

L = Limited to intermittent duty  
C = Cavitation Limit

# MP-3127

## Outline Dimensions

SECTION	PAGE
<b>9</b>	<b>11</b>
SUPERSEDES	ISSUED
6/90	6/94

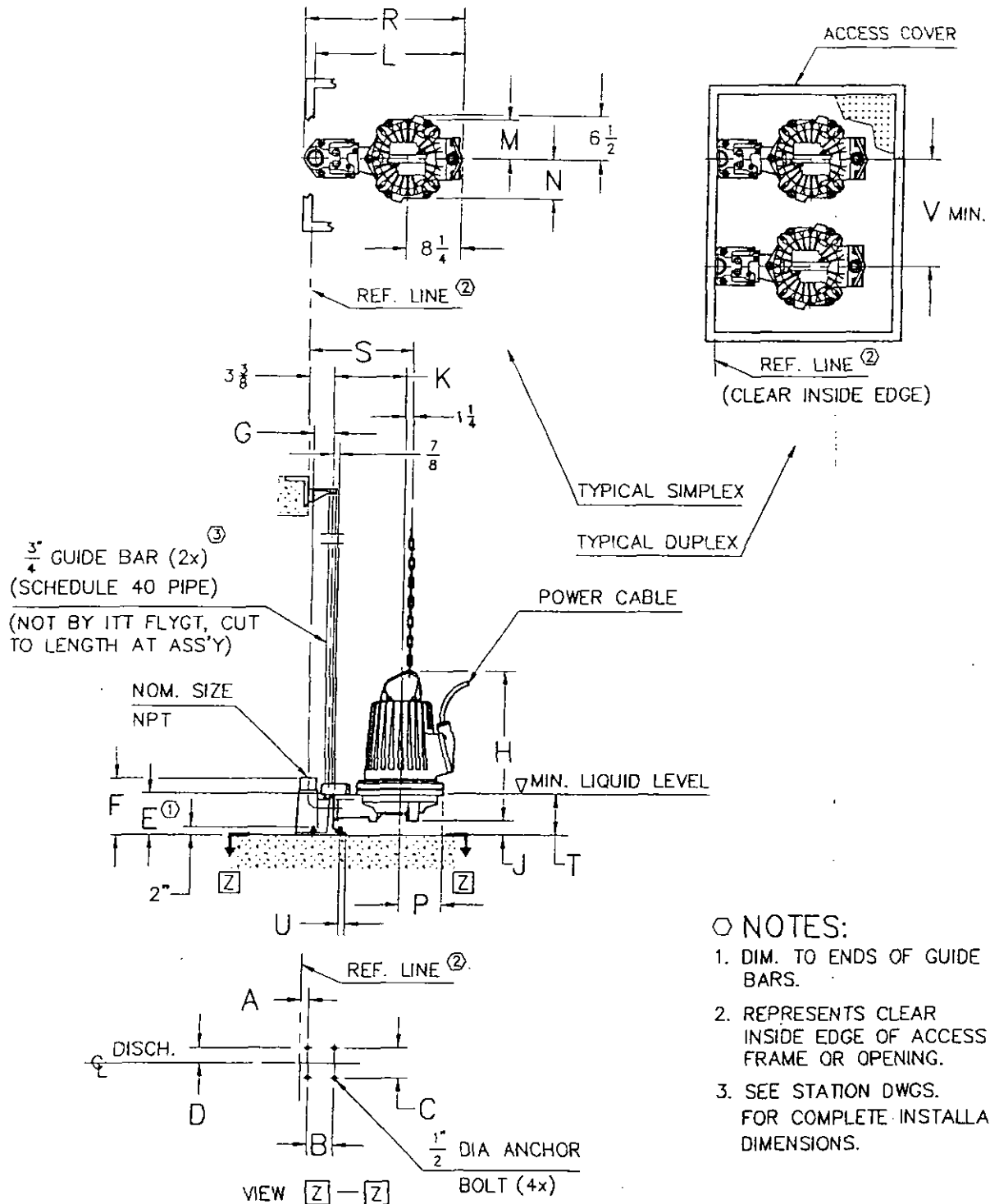

NOM. SIZE	VERSION	WEIGHT(LBS)	
		PUMP	DISCH
2"	HT/LT	250	15

ALL DIMENSIONS IN INCHES

NOM. SIZE	VERSION	DIMENSIONAL CHART																		
		A	B	C	D	E	F	G	H	J	K	L	M	N	P	R	S	T	U	V
2"	HT/LT	$1\frac{1}{4}$	4	$4\frac{1}{2}$	$2\frac{1}{4}$	$5\frac{1}{2}$	$8\frac{1}{4}$	3	22	$2\frac{1}{2}$	$10\frac{3}{4}$	$22\frac{1}{2}$	$5\frac{3}{4}$	$5\frac{3}{4}$	$6\frac{1}{2}$	$23\frac{3}{4}$	$15\frac{1}{4}$	7	$\frac{3}{4}$	$15\frac{3}{4}$



# M-3127

## Basic Arrangements (Fiberglass or steel)

SECTION	PAGE
9	13
SUPERSEDES	ISSUED
6/90	6/94

### Type MP

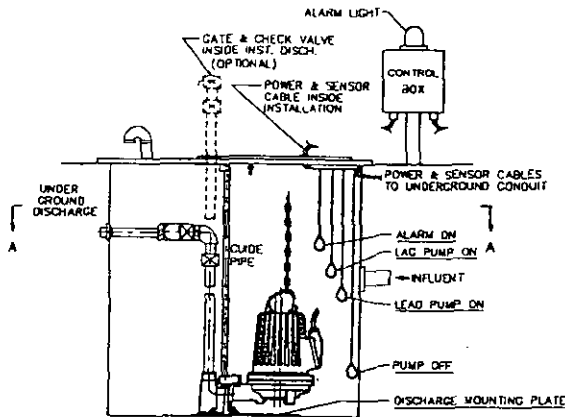
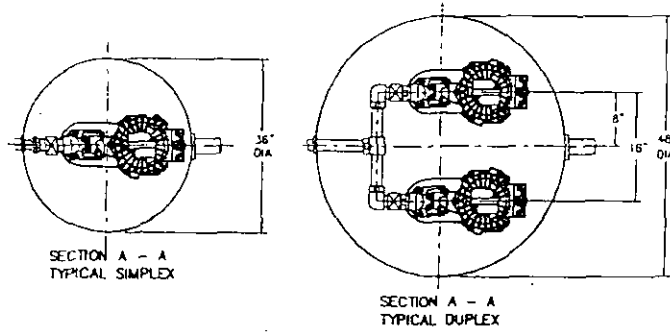

### Type MF

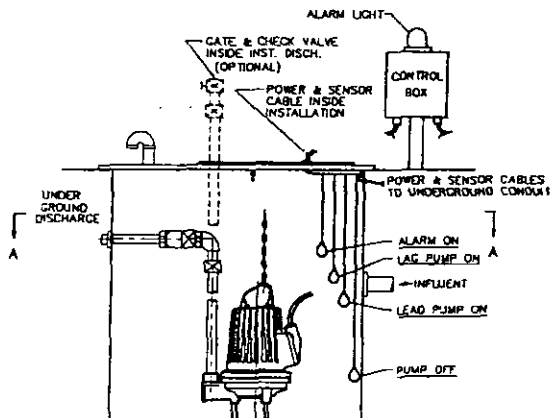
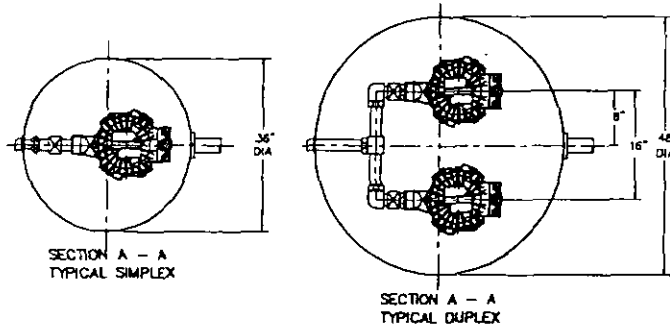

# Simplex

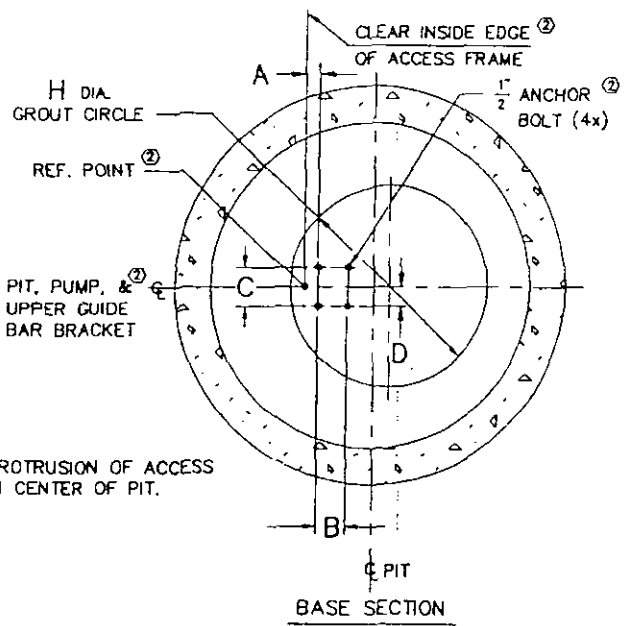
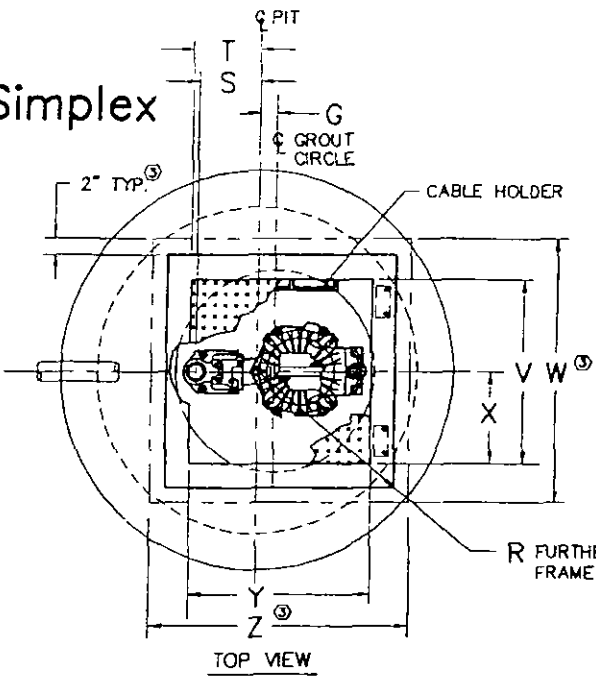

ALL DIMENSIONS IN INCHES

NOM. SIZE	VERSION	STATION											COVER								
		A	B	C	D	F	G	H	R	S	T	U	C	V	M	W	SIZE ⑥	V	W	X	Y
2"	HT/LT	1 1/2	4	4 1/2	2 1/4	8 1/2	2	25	21 1/2	11 1/2	11 1/2	60	8 7/8	7	FAPS-27 x 25	24	35	12	24	37	3

# Duplex

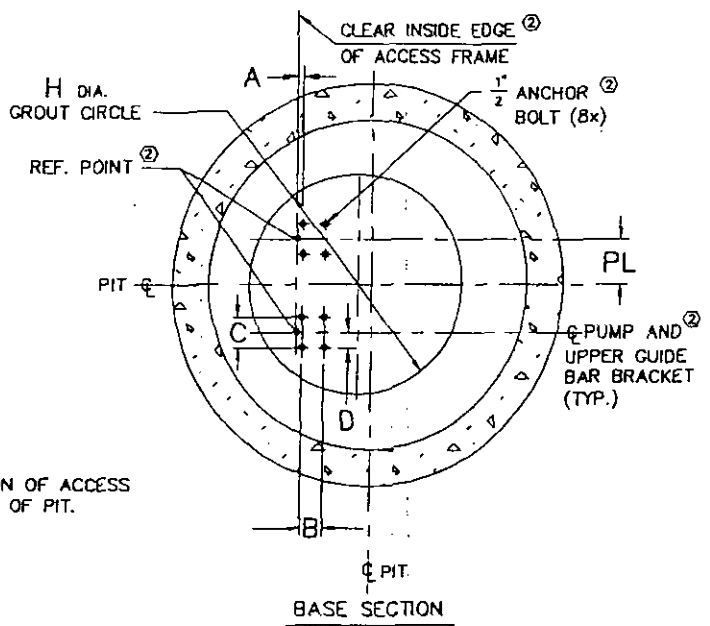
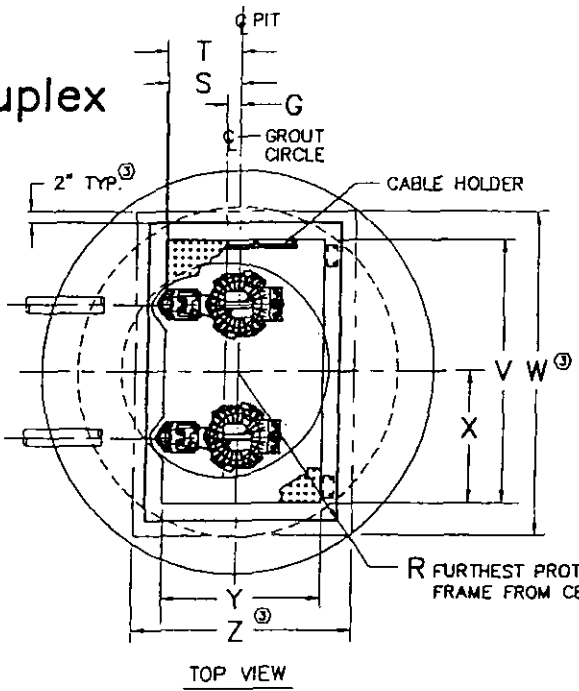

ALL DIMENSIONS IN INCHES

NOM. SIZE	VERSION	STATION													COVER							
		A	B	C	D	F	G	H	R	S	T	U	C	V	M	W	SIZE ⑥	V	W	X	Y	Z
2"	HT/LT	1 1/2	4	4 1/2	2 1/4	8 1/4	3	39	32 1/2	14 1/2	15	60	8 7/8	7	12	FAPS-34 x 49	48	59	24	30	44	3

# M-3127

## Performance Specification

SECTION	PAGE
9	17
SUPERSEDES	ISSUED
12/91	6/94

### GRINDER

Each grinder pump shall be a **heavy duty pump** modified to be used as a grinder. Each grinder pump shall contain special cutters to reduce sewage to a fine slurry. The stationary cutter shall consist of **hardened 316 "L" stainless steel** and the rotary cutter shall consist of chrome alloyed cast iron. The cutter materials shall provide maximum corrosion and abrasion resistance. The remaining portion of the grinder pumps, with the exception of seal materials and wet end, shall be similar to the heavy duty pumps used in larger pump stations for daily operation.

### REQUIREMENTS

Furnish and install \_\_\_ submersible non-clog wastewater pump(s). Each pump shall be equipped with \_\_\_ HP, submersible electric motor connected for operation on volts, \_\_\_ phase, 60 hertz, \_\_\_ wire service, with 25 feet of submersible cable (SUBCAB) suitable for submersible pump applications. The power cable shall be sized according to NEC and ICEA standards and also meet with P-MSHA Approval. The pump shall be supplied with a mating cast iron \_\_\_ inch discharge connection and be capable of delivering \_\_\_ GPM at \_\_\_ TDH. An additional point on the same curve shall be \_\_\_ GPM at \_\_\_ feet total head. Shut off head shall be \_\_\_ feet (minimum). Each pump shall be fitted with \_\_\_ feet of \_\_\_ lifting chain or stainless steel cable. The working load of the lifting system shall be 50% greater than the pump unit weight.

### PUMP DESIGN

Grinder pump(s) shall be available in the following three configurations:

1. MP - Guide Bar Mounting - 2" Discharge.
2. MF - Free Standing - 1 1/2" Discharge.

The MP Grinder pump(s) shall be automatically and firmly connected to the discharge connection, guided by no less than two guide bars extending from the top of the station to the discharge connection. There shall be no need for personnel to enter the wet-well. Sealing of the pumping unit to the discharge connection shall be accomplished by a machined metal to metal watertight contact. **Sealing of the discharge interface with a diaphragm, O-ring or profile gasket will not be acceptable.** No portion of the pump shall bear directly on the sump floor.

### PUMP CONSTRUCTION

Major pump components shall be of grey cast iron, ASTM A-48, Class 35B, with smooth surfaces devoid of blow holes or other irregularities. All exposed nuts or bolts shall be AISI type 304 stainless steel or brass construction. All metal surfaces coming into contact with the pumpage,

other than stainless steel or brass, shall be protected by a factory applied spray coating of acrylic dispersion zinc phosphate primer with a polyester resin paint finish on the exterior of the pump.

Sealing design shall incorporate **metal-to-metal contact** between machined surfaces. Critical mating surfaces where watertight sealing is required shall be machined and fitted with Nitrile or Viton rubber O-rings. Fittings will be the result of controlled compression of rubber O-rings in two planes and O-ring contact of four sides without the requirement of a specific torque limit.

Rectangular cross sectioned gaskets requiring specific torque limits to achieve compression shall not be considered as adequate or equal. No secondary sealing compounds, elliptical O-rings, grease or other devices shall be used.

### COOLING SYSTEM

Motors are sufficiently cooled by the environmental atmosphere or pumped media. A water jacket is not required.

### CABLE ENTRY SEAL

The cable entry seal design shall preclude specific torque requirements to insure a watertight and submersible seal. The cable entry shall consist of a single cylindrical elastomer grommet, flanked by washers, all having a close tolerance fit against the cable outside diameter and the entry inside diameter and compressed by the body containing a strain relief function, separate from the function of sealing the cable. The assembly shall provide ease of changing the cable when necessary using the same entry seal. **The cable entry junction chamber and motor shall be separated by a stator lead sealing gland or terminal board, which shall isolate the interior from foreign material gaining access through the pump top. Epoxies, silicones, or other secondary sealing systems shall not be considered acceptable.**

### MOTOR

The pump motor shall be induction type with a squirrel cage rotor, shell type design, housed in an air filled, watertight chamber, Nema B type. The stator windings and stator leads shall be insulated with moisture resistant Class F insulation rated for 155°C (311°F). The stator shall be dipped and baked three times in Class F varnish and shall be heat-shrink fitted into the stator housing. The use of bolts, pins or other fastening devices requiring penetration of the stator housing is not acceptable. The motor shall be designed for continuous duty handling pumped media of 40°C (104°F) and capable of up to 15 evenly spaced starts per hour. The rotor bars and short circuit rings shall be

# M-3127

## Performance Specification

SECTION	PAGE
9	19
SUPERSEDES	ISSUED
6/90	12/91

the pump manufacturer upon request. Impeller(s) shall be taper collet fitted and retained with an allen head bolt. All impellers shall be coated with an acrylic dispersion zinc phosphate primer.

### VOLUTE

Pump volute(s) shall be single-piece grey cast iron, Class 35B, non-concentric design with smooth passages large enough to pass any media that may enter the impeller. Minimum inlet and discharge size shall be as specified.

### PROTECTION

All stators shall incorporate thermal switches in series to monitor the temperature of each phase winding. At 125°C (260°F) the thermal switches shall open, stop the motor and activate an alarm.

A leakage sensor shall be available as an option to detect water in the stator chamber. The Float Leakage Sensor (FLS) is a small float switch used to detect the presence of water in the stator chamber. When activated, the FLS will send an alarm and, if desired, stop the motor. **USE OF VOLTAGE SENSITIVE SOLID STATE SENSORS AND TRIP TEMPERATURE ABOVE 125°C (260°F) SHALL NOT BE ALLOWED.**

The thermal switches and FLS shall be connected to a Mini CAS (Control and Status) monitoring unit. The Mini CAS is designed to be mounted in any control panel.

### MODIFICATIONS

1. Explosion-proof Pumps (X).

Refer to the General Guide Specifications in Tab Section 7 for additional information.

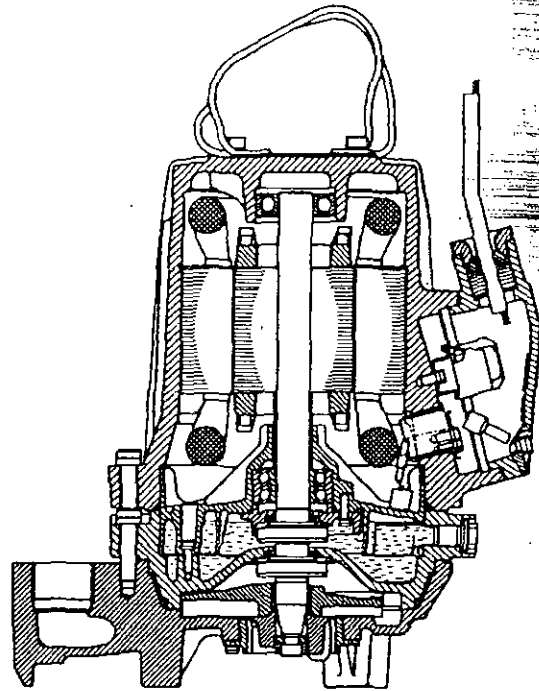

**Wet Well Calculations**

Project: McDowell Mountain Back Bowl Project Number: 042054.15  
 Location: City of Scottsdale Project Engineer: Gordon Wark, P.E.  
 Date: 10/31/2005  
 References: City of Scottsdale Design Standards  
 ADEQ Bulletin No. 11  
 Second Amended Wastewater System Study

**Fixed Parameters**

PARAMETER	VALUE	UNITS	NOTES
Maximum Retention Time	30	Min.	Max. time without odor control.
Minimum Pump Cycle Time**	10	Min.	
Wet Well Inside Diameter	6	Ft.	
Wet Well Base Elevation	2623	Ft.	
Finish Grade Elevation	2640	Ft.	
Wet Well Depth	17	Ft.	
Influent Line Invert Elevation	2630	Ft.	
Wet Well X-sectional Area	28.3	Ft <sup>2</sup>	
Pump Operating Capacity	132.2	GPM	

**Design Parameters**

PARAMETER	VALUE	UNITS	NOTES
<b>General:</b>			
Alarm Elevation	2629	Ft.	
High-High Water Elevation	2628	Ft.	(Both Pumps On)
High Water Elevation	2626	Ft.	(Pump On)
Low Water Elevation	2624	Ft.	(Pump Off)
Working Depth	2.0	Ft.	= High Water Elevation - Low Water Elevation
Wet Well Retention Depth	7.0	Ft.	= Influent Line Invert Elev. - Wet Well Base Elevation
Minimum Wet Well Volume Req't	331	Gal.	= .25 * Min. Pump Cycle Time * Pump Capacity per R18 Requirement
Wet Well Retention Volume	1480	Gal.	= Wet Well Retention Depth * X-Sectional Area * 7.48 gal/ft3
Wet Well Retention Time - Pump Failure Event	1.3	Hours	= Wet Well Retention Vol / ADWF / 60
<b>Average Daily Flow Rates:</b>			
ADWF Influent Rate	28,000	GPD	
Net Flowrate Out	19	GPM	
Wet Well Working Volume	423	Gal.	= ((High water elev. - Low water elev.)*Wet Well X-Sectional Area*7.48
Actual Pump On Time	3.8	Min.	= Wet Well Working Volume / Net Flow Rate Out
Actual Pump Off Time (ADWF Retention Time)	21.8	Min.	= Wet Well Working Volume / ADWF Influent Rate
Cycle Time*	25.5	Min.	= Pump On Time + Pump Off Time
<b>Max Daily Flow Rates:</b>			
Max Daily Influent Rate	112,000	GPD	
Max Daily Influent Rate	78	GPM	
Net Flowrate Out	54	GPM	= Pump Capacity - Max Daily Influent Rate
Wet Well Working Volume	423	Gal.	= ((High water elev. - Low water elev.)*Wet Well X-Sectional Area*7.48
Actual Pump On Time	7.8	Min.	= Wet Well Working Volume / Net Flow Rate Out
Actual Pump Off Time (ADWF Retention Time)	5.4	Min.	= Wet Well Working Volume / ADWF Influent Rate
Cycle Time*	13.2	Min.	= Pump On Time + Pump Off Time

\*Cycle times shown are for single-pump operation. The design is intended for pumps to operate in a lead-lag scenario, alternating after each cycle.

\*\*Cycle times for single-pump operation assume the pumps run in a lead-lag configuration. According to the Flygt Pump representative, Flygt pump motors can withstand cycle times as low as or lower than 2 minutes on an occasional basis to accommodate scenarios such as swimming pool drainage.



Project: Sereno Canyon Project Number: 042054.15  
 Location: City of Scottsdale Project Engineer: Gordon Wark, P.E.  
 Date: 10/31/2005  
 References: City of Scottsdale Design Standards  
 ADEQ Bulletin No. 11  
 Second Amended Wastewater System Study

**Fixed Parameters**

PARAMETER	VALUE	UNITS	NOTES
Maximum Retention Time	30	Min.	Max. time without odor control.
Minimum Pump Cycle Time**	10	Min.	
Wet Well Inside Diameter	6	Ft.	
Wet Well Base Elevation	2623	Ft.	
Finish Grade Elevation	2640	Ft.	
Wet Well Depth	17	Ft.	
Influent Line Invert Elevation	2630	Ft.	
Wet Well X-sectional Area	28.3	Ft <sup>2</sup>	
Pump Operating Capacity	132.2	GPM	

**Design Parameters**

PARAMETER	VALUE	UNITS	NOTES
<b>General:</b>			
Alarm Elevation	2629	Ft.	
High-High Water Elevation	2628	Ft.	(Both Pumps On)
High Water Elevation	2626.5	Ft.	(Pump On)
Low Water Elevation	2624	Ft.	(Pump Off)
Working Depth	2.5	Ft.	= High Water Elevation - Low Water Elevation
Wet Well Retention Depth	7.0	Ft.	= Influent Line Invert Elev. - Wet Well Base Elevation
Minimum Wet Well Volume Req'd	331	Gal.	= .25 * Min. Pump Cycle Time * Pump Capacity per R18 Requirement
Wet Well Retention Volume	1480	Gal.	= Wet Well Retention Depth * X-Sectional Area * 7.48 gal/ft <sup>3</sup>
Wet Well Retention Time - Pump Failure Event	1.0	Hours	= Wet Well Retention Vol / ADWF / 60
<b>Average Daily Flow Rates:</b>			
ADWF Influent Rate	34,000	GPD	
	24	GPM	
Net Flowrate Out	109	GPM	= Pump Capacity - ADWF Influent Rate
Wet Well Working Volume	529	Gal.	= ((High water elev. - Low water elev.)*Wet Well X-Sectional Area*7.48
Actual Pump On Time	4.9	Min.	= Wet Well Working Volume / Net Flow Rate Out
Actual Pump Off Time	22.4	Min.	= Wet Well Working Volume / ADWF Influent Rate
(ADWF Retention Time) Cycle Time*	27.3	Min.	= Pump On Time + Pump Off Time
<b>Max Daily Flow Rates:</b>			
Max Daily Influent Rate	136,000	GPD	
Max Daily Influent Rate	94	GPM	
Net Flowrate Out	38	GPM	= Pump Capacity - Max Daily Influent Rate
Wet Well Working Volume	529	Gal.	= ((High water elev. - Low water elev.)*Wet Well X-Sectional Area*7.48
Actual Pump On Time	14.0	Min.	= Wet Well Working Volume / Net Flow Rate Out
Actual Pump Off Time	5.6	Min.	= Wet Well Working Volume / ADWF Influent Rate
(ADWF Retention Time) Cycle Time*	19.6	Min.	= Pump On Time + Pump Off Time

\*Cycle times shown are for single-pump operation. The design is intended for pumps to operate in a lead-lag scenario, alternating after each cycle.

\*\*Cycle times for single-pump operation assume the pumps run in a lead-lag configuration. According to the Flygt Pump representative, Flygt pump motors can withstand cycle times as low as or lower than 2 minutes on an occasional basis to accommodate scenarios such as swimming pool drainage.

**Force Main Calculations**

# WOOD/PATEL

CIVIL ENGINEERS \* HYDROLOGISTS \* LAND SURVEYORS \* CONSTRUCTION MANAGERS

## Force Main Calculations

Project: Master Wastewater Plan for Sereno Canyon

Location: Scottsdale, Arizona

Date: October 31, 2005

References: City of Scottsdale Design Standards and Policies Manual

References: Hazen-Williams formula

Project Number: 042054.15

Project Engineer: Gordon Wark, P.E.

### Known Values:

Hazen-Williams coefficient, C =	120	DIP Force Main, "C" = 120
Initial Elevation (low water elevation in wet well)=	2,622	located at proposed sewage pumping station
Final Elevation =	2,655	Existing Stub of Granite Ridge Gravity Sewer System
Forcemain Length (ft) =	5,030	
Minor Loss Equivalent Length (10% of Length) =	503	

### Calculated Values:

Referenced Equations:

$$v = Q / A \quad (1 \text{ cfs} = 449 \text{ gpm})$$

$$A = \pi * [(D / 12) ^2] / 4$$

$$H_f = 3022 * [(v / C) ^1.85] / [(D / 12) ^1.165]$$

where: v = velocity, feet per second (fps)

Q = flow rate, gallons per minute (gpm)

A = conveyance area, square feet

D = inside pipe diameter, inches

H<sub>f</sub> = head loss, feet per thousand feet of pipe

Peak Flow (gpm)	Peak Flow (gpd)	Pipe Dia. (in.)	Velocity (fps)	Head Loss per 1,000 ft (ft)	Total Friction Head Loss (ft)	Total Dynamic Head Loss (ft)	Pressure Loss (psi)
120.0	172,800	4	3.06	12.28	17.0	50.0	22
130.0	187,200	4	3.32	14.24	18.4	51.4	22
140.0	201,600	4	3.57	16.33	19.8	52.8	23
150.0	216,000	4	3.83	18.56	21.2	54.2	23
160.0	230,400	4	4.08	20.91	22.6	55.6	24
170.0	244,800	4	4.34	23.39	24.0	57.0	25
132.2	190,368	4	3.38	14.69	18.7	51.7	22

Pump Operating Point

### Notes:

- 1) The velocity and head loss calculations are based on the peak flow rate. The pump capacity should be used for the actual flow rate during the final lift station design.
- 2) Wet well sizing, pump cycling and pump discharge rates would be designed such that the minimum flow velocity in the forcemain is not less than 4 fps.
- 4) For higher-velocity force mains, it may be required to increase the size of the forcemain prior to discharging to a manhole, etc. in order to reduce the discharge velocity.
- 5) Surge calculations should be performed to ensure that the proper pipe class is being used.
- 6) When wastewater is pumped over a considerable distance, increasing the forcemain size may reduce horsepower requirements (and operation & maintenance costs) of the lift station pumps, due to reduced friction

**APPENDIX D**

**Ultimate Buildout Condition in Area**

**Option 1**

**Table 1: Estimated Wastewater Flow Calculations – Ultimate Condition**

TABLE 1: WASTEWATER FLOW CALCULATIONS - Ultimate Condition

Project: Master Wastewater Plan for Sereno Canyon

Location: City of Scottsdale

Project Number: 042054.15

Date: 31-Oct-05

Project Engineer: Gordon Wark, P.E

References: City of Scottsdale Design Standards and Policies Manual

Site Plan for Sonoran Crest dated: 2/22/1999

Engineering Report for Construction of Sewer Facilities. Granite Ridge Subdivision, Arizona. Dated: January 23, 2002.

Sewer Quarter Section Map (46-55). City of Scottsdale, Arizona.

Site Plan for Desert Crest at Troon Ridge dated: 5/24/1991

Site Plan for The Estates at Desert Crest dated: 5/2/1991

UPSTREAM NODE	DOWNSTREAM NODE	PIPE DIA. (IN)	PIPE SLOPE (FT / FT)	RESIDENTIAL		NON-RESIDENTIAL		SUB-AREA ADF (GPD)	EQUIVALENT POPULATION	TOTAL ADF (GPD)	PEAKING FACTOR	PEAK FLOW (GPD)
				DWELLING UNITS < 2 DU/ACRE	ADF/UNIT	AREA (SQ.FT)	ADF/SQ.FT					
<b>Gravity Outfall to Alameda Road</b>												
A <sup>(1)</sup>	B	8	0.0052	14	250			3,500	35.0	3,500	4.00	14,000
C	B	8	0.0052	5	250			1,250	12.5	1,250	4.00	5,000
B	E	8	0.0052	7	250			1,750	17.5	6,500	4.00	26,000
D	E	8	0.0052	5	250			1,250	12.5	1,250	4.00	5,000
E	F	8	0.0052	1	250			250	2.5	8,000	4.00	32,000
G	F	8	0.0052	4	250			1,000	10.0	1,000	4.00	4,000
F	H	8	0.0052	4	250			1,000	10.0	10,000	4.00	40,000
H	I	8	0.0052							10,000	4.00	40,000
<b>Subtotal</b>				<b>40</b>	<b>250</b>			<b>10,000</b>	<b>100.0</b>	<b>10,000</b>		<b>40,000</b>
<b>Gravity Outfall to 128th Street Alignment</b>												
J <sup>(2)</sup>	K	8	0.0052	13	250			3,250	32.5	3,250	4.00	13,000
L	K	8	0.0052	3	250			750	7.5	750	4.00	3,000
K	N	8	0.0052	2	250			500	5.0	4,500	4.00	18,000
M	N	8	0.0052	4	250			1,000	10.0	1,000	4.00	4,000
N	P	8	0.0052	6	250			1,500	15.0	7,000	4.00	28,000
O	P	8	0.0052	5	250			1,250	12.5	1,250	4.00	5,000
P	Q	8	0.0052		0			0	0.0	8,250	4.00	33,000
<b>Subtotal</b>				<b>33</b>				<b>8,250</b>	<b>82.5</b>	<b>8,250</b>		<b>33,000</b>
<b>Gravity Outfall to the Happy Valley Road Alignment</b>												
R	S	8	0.0052	3	250	5000	0.9	5,250	52.5	5,250	4.00	21,000
T	U	8	0.0052	5	250			1,250	12.5	1,250	4.00	5,000
U	S	8	0.0052	2	250			500	5.0	1,750	4.00	7,000
S	AE	8	0.0052	3	250			750	7.5	7,750	4.00	31,000
AB	AC	8	0.0052	5	250			1,250	12.5	1,250	4.00	5,000
AD	AC	8	0.0052	4	250			1,000	10.0	1,000	4.00	4,000
AC	AE	8	0.0052		0			0	0.0	2,250	4.00	9,000
AE	AF	8	0.0052	6	250			1,500	15.0	11,500	4.00	46,000
AG <sup>(3)</sup>	AF	8	0.0052	9	250			2,250	22.5	2,250	4.00	9,000
AF	AH	8	0.0052	2	250			500	5.0	14,250	4.00	57,000
AI	AH	8	0.0052	5	250			1,250	12.5	1,250	4.00	5,000

UPSTREAM NODE	DOWNSTREAM NODE	PIPE DIA. (IN)	PIPE SLOPE (FT / FT)	RESIDENTIAL		NON-RESIDENTIAL		SUB-AREA ADF (GPD)	EQUIVALENT POPULATION	TOTAL ADF (GPD)	PEAKING FACTOR	PEAK FLOW (GPD)	
				DWELLING UNITS < 2 DU/ACRE	ADF/UNIT	AREA (SQ.FT)	ADF/SQ.FT						
AH	AJ	8	0.0052	2	250			500	5.0	16,000	4.00	64,000	
V	X	8	0.0052	2	250			500	5.0	500	4.00	2,000	
W	X	8	0.0052	3	250			750	7.5	750	4.00	3,000	
X	Z	8	0.0052	6	250			1,500	15.0	2,750	4.00	11,000	
Y	Z	8	0.0052	3	250			750	7.5	750	4.00	3,000	
Z	AA	8	0.0052	4	250			1,000	10.0	4,500	4.00	18,000	
AA	AJ	8	0.0052	4	250			1,000	10.0	5,500	4.00	22,000	
AJ	AK	8	0.0052	3	250			750	7.5	22,250	4.00	89,000	
AK	AM	8	0.0052	1	250			250	2.5	22,500	4.00	90,000	
AM	AN	8	0.0052							22,500	4.00	90,000	
<b>Subtotal</b>				<b>72</b>		<b>5000</b>	<b>0.9</b>	<b>22,500</b>	<b>225.0</b>	<b>22,500</b>			<b>90,000</b>
<b>Total</b>				<b>145</b>				<b>40,750</b>	<b>407.5</b>	<b>40,750</b>			<b>163,000</b>
<b>Outfall to Offsite Gravity Sewer System in Sonoran Crest to Happy Valley Road</b>													
I	NODE 1	8	0.0200					10,000	100.0	10,000	4.00	40,000	
NODE 1	NODE 2	8	0.0239							10,000	4.00	40,000	
NODE 2	NODE 3	8	0.0196							10,000	4.00	40,000	
NODE 4	NODE 5	8	0.0052							10,000	4.00	40,000	
NODE 5 <sup>(4)</sup>	NODE 6	8	0.0052	42	250			10,500	105.0	20,500	4.00	82,000	
NODE 6	NODE 7	8	0.0250							20,500	4.00	82,000	
NODE 7	NODE 8	8	0.0281							20,500	4.00	82,000	
NODE 8 <sup>(5)</sup>	NODE 9	8	0.0052	90	250			22,500	225.0	43,000	4.00	172,000	
NODE 9 <sup>(5)</sup>	NODE 10	8	0.0052	19	250			4,750	47.5	47,750	4.00	191,000	
NODE 10 <sup>(5)</sup>	NODE 11	8	0.0052	48	250			12,000	120.0	59,750	4.00	239,000	
<b>Outfall to Grannite Ridge Sewer System to Happy Valley Road</b>													
Q <sup>(6)</sup>	AN	8	0.0052	52	250			13000	130	21,250	4.00	85,000	
AM	AN	8	0.0052		0					22,500	4.00	90,000	
AN1 <sup>(7)</sup>	AN	8	0.0052	94	250			23500	235	23,500	4.00	94,000	
AN2 <sup>(8)</sup>	AN	8	0.0052	166	250			41500	415	41,500	4.00	166,000	
AN	AO		FM		0					108,750	4.00	435,000	
AO <sup>(9)</sup>	AP	8	0.0052	16	250			4000	40	112,750	4.00	451,000	
AP	AQ	8	0.0052		0					112,750	4.00	451,000	
AQ <sup>(10)</sup>	AR	8	0.0052	3	250			750	8	113,500	4.00	454,000	
AR1	AR2	8	0.0055		0					113,500	4.00	454,000	
AR2 <sup>(10)</sup>	AR3	8	0.0064	1	250			250	3	113,750	4.00	455,000	
AR3	AR4	8	0.0442		0					113,750	4.00	455,000	
AR4 <sup>(10)</sup>	AR5	8	0.0055	7	250			1750	18	115,500	4.00	462,000	
AR5 <sup>(10)</sup>	AR6	8	0.0055	1	250			250	3	115,750	4.00	463,000	
AR6	AS	8	0.0056		0					115,750	4.00	463,000	
AS <sup>(11)</sup>	AT	8	0.0129	6	250			1500	15	117,250	4.00	469,000	
AT	AU	8	0.0126		0			0	0	117,250	4.00	469,000	
AU <sup>(12)</sup>	AV	8	0.0208	12	250			3000	30	120,250	4.00	481,000	
AV	AW	8	0.0420	10	250			2500	25	122,750	4.00	491,000	
AW	AX	8	0.0449	5	250			1250	13	124,000	4.00	496,000	
AX	AY	8	0.0060	3	250			750	8	124,750	4.00	499,000	
AY	AZ	8	0.0227	1	250			250	3	125,000	4.00	500,000	

UPSTREAM NODE	DOWNSTREAM NODE	PIPE DIA. (IN)	PIPE SLOPE (FT / FT)	RESIDENTIAL		NON-RESIDENTIAL		SUB-AREA ADF (GPD)	EQUIVALENT POPULATION	TOTAL ADF (GPD)	PEAKING FACTOR	PEAK FLOW (GPD)
				DWELLING UNITS < 2 DU/ACRE	ADF/UNIT	AREA (SQ.FT)	ADF/SQ.FT					
AZ <sup>(13)</sup>	AA1	8	0.0296	15	250			3750	38	128,750	4.00	515,000
AA1 <sup>(14)</sup>	AA2	8	0.0238	32	250			8000	80	136,750	4.00	547,000
AA2 <sup>(15)</sup>	AA3	8	0.0282	4	250			1000	10	137,750	4.00	551,000
AA3 <sup>(15)</sup>	AA4	8	0.0164	10	250			2500	25	140,250	4.00	561,000
AA4 <sup>(15)</sup>	AA5	8	0.0351	2	250			500	5	140,750	4.00	563,000
AA5 <sup>(15)</sup>	AA6	8	0.0226	14	250			3500	35	144,250	4.00	577,000
AA6	Ex. MH	8	0.0040		0					144,250	4.00	577,000

Note:

- 1) Contributing flows include flows generated from 12 lots south of Crown Property
- 2) Contributing flows include flows generated from 7 lots south of Crown Property
- 3) Contributing flows include flows generated from 4 lots west of Crown Property
- 4) Contributing flows include flows generated from 42 lots in Sonoran Crest.
- 5) Contributing flows include flows generated from lots south of Alameda within Quarter Sections 44-56 (Section 15 T4N R5E), 44-57 (Section 14 T4N R5E), 45-56, 46-56 (Section 10 T4N R5E)
- 6) Contributing flows include flows generated from 118 acres east of crown property and 47 acres south east of the property boundary. The number of lots estimated at .31 DU/acre.
- 7) Contributing flows include flows generated from 300 acres. The number of lots estimated at .31 DU/acre
- 8) Contributing flows include flows generated from 537 acres. The number of lots estimated at .31 DU/acre
- 9) Contributing flows include flows generated from 16 lots in Sonoran Crest.
- 10) Contributing flows include flows generated by lots in Granite Ridge.
- 11) Contributing flows include flows generated from 6 lots in The Estates at Desert Crest.
- 12) Contributing flows include flows generated from lots in Desert Crest at Troon Ridge
- 13) Contributing flows include flows generated from 7 Desert Crest at Troon Ridge and 8 lots from other property
- 14) Contributing flows include flows generated from 20 lots in Desert Crest at Troon Ridge, 8 lots in the estates at Desert Crest and 4 lots from other property
- 15) Contributing flows include flows generated from lots in Desert Crest at Troon Ridge



Option 1

**Table 2: Estimated Pipe Capacities – Ultimate Condition**

**TABLE 2: ESTIMATED PIPE CAPACITIES - Ultimate Condition**

Project: Master Wastewater Plan for Sereno Canyon  
 Location: Scottsdale, Arizona  
 Date: 31-Oct-05

Project Number: 042054.15  
 Project Engineer: Gordon Wark, P.E

FROM NODE	TO NODE	PIPE SIZE (IN)	PEAK FLOW (GPD)	PIPE SLOPE (FT/FT)	FULL FLOW VELOCITY, V <sub>0</sub> (FPS)	PARTIAL FLOW VELOCITY, V <sub>1</sub> (FPS)	PIPE CAPACITY (GPD)	SURPLUS CAPACITY (GPD)	d/D
<b>Gravity Outfall to Alameda Road</b>									
A(1)	B	8	14,000	0.0052	2.5	1.1	564,339	550,339	0.11
C	B	8	5,000	0.0052	2.5	0.8	564,339	559,339	0.07
B	E	8	26,000	0.0052	2.5	1.3	564,339	538,339	0.15
D	E	8	5,000	0.0052	2.5	0.8	564,339	559,339	0.07
E	F	8	32,000	0.0052	2.5	1.4	564,339	532,339	0.16
G	F	8	4,000	0.0052	2.5	0.7	564,339	560,339	0.06
F	H	8	40,000	0.0052	2.5	1.4	564,339	524,339	0.18
H	I	8	40,000	0.0052	2.5	1.4	564,339	524,339	0.18
<b>Gravity Outfall to 128th Street Alignment</b>									
J(2)	K	8	13,000	0.0052	2.5	1.0	564,339	551,339	0.10
L	K	8	3,000	0.0052	2.5	0.7	564,339	561,339	0.05
K	N	8	18,000	0.0052	2.5	1.1	564,339	546,339	0.12
M	N	8	4,000	0.0052	2.5	0.7	564,339	560,339	0.06
N	P	8	28,000	0.0052	2.5	1.3	564,339	536,339	0.15
O	P	8	5,000	0.0052	2.5	0.8	564,339	559,339	0.07
P	Q	8	33,000	0.0052	2.5	1.4	564,339	531,339	0.16
<b>Gravity Outfall to the Happy Valley Road Alignment</b>									
R	S	8	21,000	0.0052	2.5	1.2	564,339	543,339	0.13
T	U	8	5,000	0.0052	2.5	0.8	564,339	559,339	0.07
U	S	8	7,000	0.0052	2.5	0.9	564,339	557,339	0.08
S	AE	8	31,000	0.0052	2.5	1.3	564,339	533,339	0.16
AB	AC	8	5,000	0.0052	2.5	0.8	564,339	559,339	0.07
AD	AC	8	4,000	0.0052	2.5	0.7	564,339	560,339	0.06
AC	AE	8	9,000	0.0052	2.5	0.9	564,339	555,339	0.09
AE	AF	8	46,000	0.0052	2.5	1.5	564,339	518,339	0.19
AG(3)	AF	8	9,000	0.0052	2.5	0.9	564,339	555,339	0.09
AF	AH	8	57,000	0.0052	2.5	1.6	564,339	507,339	0.21
AI	AH	8	5,000	0.0052	2.5	0.8	564,339	559,339	0.07
AH	AJ	8	64,000	0.0052	2.5	1.7	564,339	500,339	0.23
V	X	8	2,000	0.0052	2.5	0.6	564,339	562,339	0.04
W	X	8	3,000	0.0052	2.5	0.7	564,339	561,339	0.05
X	Z	8	11,000	0.0052	2.5	1.0	564,339	553,339	0.10
Y	Z	8	3,000	0.0052	2.5	1.5	564,339	561,339	0.18
Z	AA	8	18,000	0.0052	2.5	1.1	564,339	546,339	0.12
AA	AJ	8	22,000	0.0052	2.5	1.2	564,339	542,339	0.13
AJ	AK	8	89,000	0.0052	2.5	1.8	564,339	475,339	0.27
AK	AM	8	90,000	0.0052	2.5	1.8	564,339	474,339	0.27
AM	AN	8	90,000	0.0052	2.5	1.8	564,339	474,339	0.27
<b>Outfall to Offsite Gravity Sewer System in Sonoran Crest to Happy Valley Road</b>									
I	NODE 1	8	40,000	0.0200	4.9	2.3	1,106,761	1,066,761	0.13
NODE 1	NODE 2	8	40,000	0.0239	5.4	2.5	1,209,867	1,169,867	0.12
NODE 2	NODE 3	8	40,000	0.0196	4.9	2.3	1,095,637	1,055,637	0.13
NODE 4	NODE 5	8	40,000	0.0052	2.5	1.4	564,339	524,339	0.18
NODE 5 (4)	NODE 6	8	82,000	0.0052	2.5	1.8	564,339	482,339	0.26
NODE 6	NODE 7	8	82,000	0.0250	5.5	3.1	1,237,396	1,155,396	0.17
NODE 7	NODE 8	8	82,000	0.0281	5.8	3.2	1,311,873	1,229,873	0.17
NODE 8 (5)	NODE 9	8	172,000	0.0052	2.5	2.2	564,339	392,339	0.38
NODE 9 (5)	NODE 10	8	191,000	0.0052	2.5	2.3	564,339	373,339	0.40
NODE 10 (5)	NODE 11	8	239,000	0.0052	2.5	2.4	564,339	325,339	0.45
<b>Outfall to Grannite Ridge Sewer System to Happy Valley Road</b>									

FROM NODE	TO NODE	PIPE SIZE (IN)	PEAK FLOW (GPD)	PIPE SLOPE (FT/FT)	FULL FLOW VELOCITY, V <sub>0</sub> (FPS)	PARTIAL FLOW VELOCITY, V <sub>1</sub> (FPS)	PIPE CAPACITY (GPD)	SURPLUS CAPACITY (GPD)	d/D
Q (6)	AN	8	85,000	0.0052	2.5	1.8	564,339	479,339	0.26
AM	AN	8	90,000	0.0052	2.5	1.8	564,339	474,339	0.27
AN1 (7)	AN	8	94,000	0.0052	2.5	1.9	564,339	470,339	0.28
AN2 (8)	AN	8	166,000	0.0052	2.5	2.2	564,339	398,339	0.37
AN	AO	0	435,000	FM					
AO (9)	AP	8	451,000	0.0052	2.5	2.8	564,339	113,339	0.67
AP	AQ	8	451,000	0.0052	2.5	2.8	564,339	113,339	0.67
AQ (10)	AR	8	454,000	0.0052	2.5	2.8	564,339	110,339	0.67
AR1	AR2	8	454,000	0.0055	2.6	2.8	580,390	126,390	0.66
AR2 (10)	AR3	8	455,000	0.0064	2.8	3.0	626,078	171,078	0.63
AR3	AR4	8	455,000	0.0442	7.3	6.2	1,644,573	1,189,573	0.36
AR4 (10)	AR5	8	462,000	0.0055	2.6	2.9	580,390	118,390	0.67
AR5 (10)	AR6	8	463,000	0.0055	2.6	2.9	580,390	117,390	0.67
AR6	AS	8	463,000	0.0056	2.6	2.9	585,643	122,643	0.67
AS (11)	AT	8	469,000	0.0129	3.9	4.0	888,860	419,860	0.51
AT	AU	8	469,000	0.0126	3.9	3.9	878,464	409,464	0.52
AU (12)	AV	8	481,000	0.0208	5.0	4.8	1,128,679	647,679	0.45
AV	AW	8	491,000	0.0420	7.1	6.2	1,603,849	1,112,849	0.38
AW	AX	8	496,000	0.0449	7.4	6.4	1,658,295	1,162,295	0.37
AX	AY	8	499,000	0.0060	2.7	3.0	606,198	107,198	0.69
AY	AZ	8	500,000	0.0227	5.2	5.0	1,179,103	679,103	0.45
AZ (13)	AA1	8	515,000	0.0296	6.0	5.6	1,346,433	831,433	0.43
AA1 (14)	AA2	8	547,000	0.0238	5.4	5.2	1,207,333	660,333	0.47
AA2 (15)	AA3	8	551,000	0.0282	5.8	5.6	1,314,206	763,206	0.45
AA3 (15)	AA4	8	561,000	0.0164	4.4	4.6	1,002,214	441,214	0.53
AA4 (15)	AA5	8	563,000	0.0351	6.5	6.1	1,466,197	903,197	0.43
AA5 (15)	AA6	8	577,000	0.0226	5.2	5.2	1,176,503	599,503	0.49
AA6	Ex. MH	8	577,000	0.0040	2.2	2.4	494,958	-82,042	0.94

Option 2

**Table 1: Estimated Wastewater Flow Calculations – Ultimate Condition**

**TABLE 1: WASTEWATER FLOW CALCULATIONS - Ultimate Condition**

Project: Master Wastewater Plan for Sereno Canyon

Project Number: 042054.15

Location: City of Scottsdale

Project Engineer: Gordon Wark, P.E

Date: 31-Oct-05

References: City of Scottsdale Design Standards and Policies Manual

Site Plan for Sonoran Crest dated: 2/22/1999

Engineering Report for Construction of Sewer Facilities. Granite Ridge Subdivision, Arizona. Dated: January 23, 2002.

Sewer Quarter Section Maps. City of Scottsdale, Arizona.

Site Plan for Desert Crest at Troon Ridge dated: 5/24/1991

Site Plan for The Estates at Desert Crest dated: 5/2/1991

UPSTREAM NODE	DOWNSTREAM NODE	PIPE DIA. (IN)	PIPE SLOPE (FT / FT)	RESIDENTIAL		NON-RESIDENTIAL		SUB-AREA ADF (GPD)	EQUIVALENT POPULATION	TOTAL ADF (GPD)	TOTAL EQUIVALENT POPULATION	PEAKING FACTOR	PEAK FLOW (GPD)
				DWELLING UNITS < 2 DU/ACRE	ADF/UNIT	AREA (SQ.FT)	ADF/SQ.FT						
<b>Gravity Outfall to the West</b>													
A <sup>(1)</sup>	B	8	0.0052	14	250			3,500	35	3,500	35	4.00	14,000
C	B	8	0.0052	5	250			1,250	13	1,250	13	4.00	5,000
B	E	8	0.0052	7	250			1,750	18	6,500	65	4.00	26,000
D	E	8	0.0052	5	250			1,250	13	1,250	13	4.00	5,000
E	F	8	0.0052	2	250			500	5	8,250	83	4.00	33,000
G	F	8	0.0052	4	250			1,000	10	1,000	10	4.00	4,000
F	H	8	0.0052	3	250			750	8	10,000	100	4.00	40,000
H	I	8	0.0052		0			0	0	10,000	100	4.00	40,000
<b>Subtotal</b>				<b>40</b>	<b>250</b>			<b>10,000</b>		<b>10,000</b>	<b>100</b>		<b>40,000</b>
<b>Gravity Outfall to the East at Node Q</b>													
J	J1	8	0.0052	1	250			250	3	250	3	4.00	1,000
A1	J1	8	0.0052	6	250			1,500	15	1,500	15	4.00	6,000
J1	K	8	0.0052	5	250			1,250	13	3,000	30	4.00	12,000
A2	K	8	0.0052	1	250			250	3	250	3	4.00	1,000
L	K	8	0.0052	4	250			1,000	10	1,000	10	4.00	4,000
K	N	8	0.0052	1	250			250	3	4,500	45	4.00	18,000
M	N	8	0.0052	5	250			1,250	13	1,250	13	4.00	5,000
N	P	8	0.0052	5	250			1,250	13	7,000	70	4.00	28,000
O	P	8	0.0052	5	250			1,250	13	1,250	13	4.00	5,000
P	Q	8	0.0052		0			0	0	8,250	83	4.00	33,000
<b>Subtotal</b>				<b>33</b>				<b>8,250</b>		<b>8,250</b>	<b>83</b>		<b>33,000</b>
<b>Gravity Outfall to the East at Node AM</b>													
R	S	8	0.0052	3	250	5000	0.9	5,250	53	5,250	53	4.00	21,000
T	U	8	0.0052	6	250			1,500	15	1,500	15	4.00	6,000
U	S	8	0.0052	1	250			250	3	1,750	18	4.00	7,000
S	AE	8	0.0052	4	250			1,000	10	8,000	80	4.00	32,000
AB	AC	8	0.0052	5	250			1,250	13	1,250	13	4.00	5,000
AD	AC	8	0.0052	5	250			1,250	13	1,250	13	4.00	5,000
AC	AE	8	0.0052		0			0	0	2,500	25	4.00	10,000
AE	AF	8	0.0052	5	250			1,250	13	11,750	118	4.00	47,000
AG	AF	8	0.0052	8	250			2,000	20	2,000	20	4.00	8,000

UPSTREAM NODE	DOWNSTREAM NODE	PIPE DIA. (IN)	PIPE SLOPE (FT / FT)	DWELLING UNITS < 2 DU/ACRE	ADF/UNIT	AREA (SQ.FT)	ADF/SQ.FT	SUB-AREA ADF (GPD)	EQUIVALENT POPULATION	TOTAL ADF (GPD)	TOTAL EQUIVALENT POPULATION	PEAKING FACTOR	PEAK FLOW (GPD)
AF	AH	8	0.0052	3	250			750	8	14,500	145	4.00	58,000
AI	AH	8	0.0052	5	250			1,250	13	1,250	13	5.00	6,250
AH	AJ	8	0.0052	1	250			250	3	16,000	160	4.00	64,000
V	X	8	0.0052	2	250			500	5	500	5	4.00	2,000
W	X	8	0.0052	3	250			750	8	750	8	4.00	3,000
X	Z	8	0.0052	5	250			1,250	13	2,500	25	4.00	10,000
Y	Z	8	0.0052	3	250			750	8	750	8	4.00	3,000
Z	AA	8	0.0052	4	250			1,000	10	4,250	43	4.00	17,000
AA	AJ	8	0.0052	6	250			1,500	15	5,750	58	4.00	23,000
AJ	AK	8	0.0052	3	250			750	8	22,500	225	4.00	90,000
AK	AA2	8	0.0052	5	250			1,250	13	23,750	238	4.00	95,000
AA1	AA2	8	0.0052	8	250			2,000	20	2,000	20	4.00	8,000
AA2	AM	8	0.0052							25,750	258	4.00	103,000
<b>Subtotal</b>				<b>85</b>		<b>5,000</b>	<b>0.9</b>	<b>25,750</b>		<b>25,750</b>	<b>258</b>		<b>103,000</b>
<b>Total</b>				<b>158</b>				<b>44,000</b>		<b>44,000</b>	<b>440</b>		<b>176,000</b>

**Gravity Outfall to the Alameda Sewer Line in Sonoran Crest to Happy Valley Road**

I	NODE 1	8	0.0200					-	-	10,000	100	4	40,000
NODE 1	NODE 2	8	0.0239							10,000	100	4	40,000
NODE 2	NODE 3	8	0.0196							10,000	100	4	40,000
NODE 4	NODE 5	8	0.0052							10,000	100	4	40,000
NODE 5 <sup>(2)</sup>	NODE 6	8	0.0052	42	250			10,500	105	20,500	205	4	82,000
NODE 6	NODE 7	8	0.0250						0	20,500	205	4	82,000
NODE 7	NODE 8	8	0.0281						0	20,500	205	4	82,000
NODE 8 <sup>(3)</sup>	NODE 9	8	0.0052	90	250			22,500	225	43,000	205	4	172,000
NODE 9 <sup>(3)</sup>	NODE 10	8	0.0052	19	250			4,750	47.5	47,750	205	4	191,000
NODE 10 <sup>(3)</sup>	NODE 11	8	0.0052	48	250			12,000	120	59,750	205	4	239,000

**Outfall to the Granite Ridge Sewer System to Happy Valley Road**

Q <sup>(4)</sup>	AM	8	0.0052	39	250			9,750	97.5	18,000	83	4	72,000
AM	AN	8	0.0052							43,750	340	4	175,000
AN1 <sup>(5)</sup>	AN	8	0.0052	94	250			23,500	235	23,500	780	4	94,000
AN2 <sup>(6)</sup>	AN	8	0.0052	166	250			41,500	415	41,500	780	4	166,000
AN	A0		FM							108,750	340	4	435,000
A0 <sup>(7)</sup>	AP	8	0.0052	16	250			4,000	40	112,750	380	4	451,000
AP	AQ	8	0.0052					0	0	112,750	380	4	451,000
AQ <sup>(8)</sup>	AR	8	0.0052	3	250			750	7.5	113,500	388	4	454,000
AR1	AR2	8	0.0055					0	0	113,500	388	4	454,000
AR2 <sup>(8)</sup>	AR3	8	0.0064	1	250			250	2.5	113,750	390	4	455,000
AR3	AR4	8	0.0442					0	0	113,750	390	4	455,000
AR4 <sup>(8)</sup>	AR5	8	0.0055	7	250			1,750	17.5	115,500	408	4	462,000
AR5 <sup>(8)</sup>	AR6	8	0.0055	1	250			250	2.5	115,750	410	4	463,000
AR6	AS	8	0.0056					0	0	115,750	410	4	463,000
AS <sup>(8)</sup>	AT	8	0.0129	6	250			1,500	15	117,250	425	4	469,000
AT	AU	8	0.0126					0	0	117,250	425	4	469,000
AU <sup>(10)</sup>	AV	8	0.0208	12	250			3,000	30	120,250	455	4	481,000
AV	AW	8	0.0420	10	250			2,500	25	122,750	480	4	491,000
AW	AX	8	0.0449	5	250			1,250	12.5	124,000	493	4	496,000
AX	AY	8	0.0060	3	250			750	7.5	124,750	500	4	499,000
AY	AZ	8	0.0227	1	250			250	2.5	125,000	503	4	500,000
AZ <sup>(11)</sup>	AA1	8	0.0296	15	250			3,750	37.5	128,750	540	4	515,000

UPSTREAM NODE	DOWNSTREAM NODE	PIPE DIA. (IN)	PIPE SLOPE (FT / FT)	DWELLING UNITS < 2 DU/ACRE	ADF/UNIT	AREA (SQ.FT)	ADF/SQ.FT	SUB-AREA ADF (GPD)	EQUIVALENT POPULATION	TOTAL ADF (GPD)	TOTAL EQUIVALENT POPULATION	PEAKING FACTOR	PEAK FLOW (GPD)
AA1 <sup>(12)</sup>	AA2	8	0.0238	32	250			8,000	80	136,750	620	4	547,000
AA2 <sup>(13)</sup>	AA3	8	0.0282	4	250			1,000	10	137,750	630	4	551,000
AA3 <sup>(14)</sup>	AA4	8	0.0164	10	250			2,500	25	140,250	655	4	561,000
AA4 <sup>(15)</sup>	AA5	8	0.0351	2	250			500	5	140,750	660	4	563,000
AA5 <sup>(18)</sup>	AA6	8	0.0226	14	250			3,500	35	144,250	695	4	577,000
AA6	Ex. MH	8	0.0040					0	0	144,250	695	4	577,000

Note:

- 1) Contributing Flow includes flow generated from 12 lots from south of the property.
- 2) Contributing flows include flows generated from 42 lots in Sonoran Crest.
- 3) Contributing flows include flows generated from lots south of Alameda within Quarter Sections 44-56 (Section 15 T4N R5E), 44-57 (Section 14 T4N R5E), 45-56, 46-56 (Section 10 T4N R5E).
- 4) Contributing flows include flows generated from 76 acres east and 47 acres south east of crown property. The number of lots estimated at 0.31 DU/acre.
- 5) Contributing flows include flows generated from 300 acres. The number of lots estimated at .30 DU/acre
- 6) Contributing flows include flows generated from 537 acres. The number of lots estimated at .30 DU/acre
- 7) Contributing flows include flows generated from 16 lots in Sonoran Crest.
- 8) Contributing flows include flows generated by lots in Granite Ridge.
- 9) Contributing flows include flows generated from 6 lots in The Estates at Desert Crest.
- 10) Contributing flows include flows generated from lots in Desert Crest at Troon Ridge
- 11) Contributing flows include flows generated from 7 Desert Crest at Troon Ridge and 8 lots from other property
- 12) Contributing flows include flows generated from 20 lots in Desert Crest at Troon Ridge, 8 lots in the estates at Desert Crest and 4 lots from other property
- 13) Contributing flows include flows generated from lots in Desert Crest at Troon Ridge
- 14) Contributing flows include flows generated from lots in Desert Crest at Troon Ridge
- 15) Contributing flows include flows generated from lots in Desert Crest at Troon Ridge

Option 2

**Table 2: Estimated Pipe Capacities – Ultimate Condition**



**TABLE 2: ESTIMATED PIPE CAPACITIES - Ultimate Condition**

Project: Master Wastewater Plan for Sereno Canyon  
 Location: Scottsdale, Arizona  
 Date: 31-Oct-05

Project Number: 042054.15  
 Project Engineer: Gordon Wark, P.E

FROM NODE	TO NODE	PIPE SIZE (IN)	PEAK FLOW (GPD)	PIPE SLOPE (FT/FT)	FULL FLOW VELOCITY, V <sub>0</sub> (FPS)	PARTIAL FLOW VELOCITY, V <sub>1</sub> (FPS)	PIPE CAPACITY (GPD)	SURPLUS CAPACITY (GPD)	d/D
<b>Gravity Outfall to the West</b>									
A(1)	B	8	14,000	0.0052	2.5	1.1	564,339	550,339	0.11
C	B	8	5,000	0.0052	2.5	0.8	564,339	559,339	0.07
B	E	8	26,000	0.0052	2.5	1.3	564,339	538,339	0.15
D	E	8	5,000	0.0052	2.5	0.8	564,339	559,339	0.07
E	F	8	33,000	0.0052	2.5	1.4	564,339	531,339	0.16
G	F	8	4,000	0.0052	2.5	0.7	564,339	560,339	0.06
F	H	8	40,000	0.0052	2.5	1.4	564,339	524,339	0.18
H	I	8	40,000	0.0052	2.5	1.4	564,339	524,339	0.18
<b>Gravity Outfall to the East at Node Q</b>									
J	J1	8	1,000	0.0052	2.5	0.5	564,339	563,339	0.03
A1	J1	8	6,000	0.0052	2.5	0.8	564,339	558,339	0.07
J1	K	8	12,000	0.0052	2.5	1.0	564,339	552,339	0.10
L	K	8	4,000	0.0052	2.5	0.7	564,339	560,339	0.06
K	N	8	18,000	0.0052	2.5	1.1	564,339	546,339	0.12
M	N	8	5,000	0.0052	2.5	0.8	564,339	559,339	0.07
N	P	8	28,000	0.0052	2.5	1.3	564,339	536,339	0.15
O	P	8	5,000	0.0052	2.5	0.8	564,339	559,339	0.07
P	Q	8	33,000	0.0052	2.5	1.4	564,339	531,339	0.16
<b>Gravity Outfall to the East at Node AM</b>									
R	S	8	21,000	0.0052	2.5	1.2	564,339	543,339	0.13
T	U	8	6,000	0.0052	2.5	0.8	564,339	558,339	0.07
U	S	8	7,000	0.0052	2.5	0.9	564,339	557,339	0.08
AB	AC	8	5,000	0.0052	2.5	0.8	564,339	559,339	0.07
AD	AC	8	5,000	0.0052	2.5	0.8	564,339	559,339	0.07
AC	AE	8	10,000	0.0052	2.5	1.0	564,339	554,339	0.09
AE	AF	8	47,000	0.0052	2.5	1.5	564,339	517,339	0.20
AG	AF	8	8,000	0.0052	2.5	0.9	564,339	556,339	0.08
AF	AH	8	58,000	0.0052	2.5	1.6	564,339	506,339	0.22
AI	AH	8	6,250	0.0052	2.5	0.8	564,339	558,089	0.07
AH	AJ	8	64,000	0.0052	2.5	1.7	564,339	500,339	0.23
V	X	8	2,000	0.0052	2.5	0.6	564,339	562,339	0.04
W	X	8	3,000	0.0052	2.5	0.7	564,339	561,339	0.05
X	Z	8	10,000	0.0052	2.5	1.0	564,339	554,339	0.09
Y	Z	8	3,000	0.0052	2.5	0.7	564,339	561,339	0.05
Z	AA	8	17,000	0.0052	2.5	1.1	564,339	547,339	0.12
AA	AJ	8	23,000	0.0052	2.5	1.2	564,339	541,339	0.14
AJ	AK	8	90,000	0.0052	2.5	1.8	564,339	474,339	0.27
AK	AA2	8	95,000	0.0052	2.5	1.9	564,339	469,339	0.28
AA1	AA2	8	8,000	0.0052	2.5	0.9	564,339	556,339	0.08
AA2	AM	8	103,000	0.0052	2.5	2	564,339	461,339	0.29
<b>Gravity Outfall to the Alameda Sewer Line in Sonoran Crest to Happy Valley Road</b>									
I	NODE 1	8	40,000	0.0200	4.9	2.3	1,106,761	1,066,761	0.13
NODE 1	NODE 2	8	40,000	0.0239	5.4	2.5	1,209,867	1,169,867	0.12
NODE 2	NODE 3	8	40,000	0.0196	4.9	2.3	1,095,637	1,055,637	0.13
NODE 4	NODE 5	8	40,000	0.0052	2.5	1.4	564,339	524,339	0.18
NODE 5(2)	NODE 6	8	82,000	0.0052	2.5	1.8	564,339	482,339	0.26
NODE 6	NODE 7	8	82,000	0.0250	5.5	3.1	1,237,396	1,155,396	0.17
NODE 7	NODE 8	8	82,000	0.0281	5.8	3.2	1,311,873	1,229,873	0.17
NODE 8 (3)	NODE 9	8	172,000	0.0052	2.5	2.2	564,339	392,339	0.38

FROM NODE	TO NODE	PIPE SIZE (IN)	PEAK FLOW (GPD)	PIPE SLOPE (FT/FT)	FULL FLOW VELOCITY, V <sub>0</sub> (FPS)	PARTIAL FLOW VELOCITY, V <sub>1</sub> (FPS)	PIPE CAPACITY (GPD)	SURPLUS CAPACITY (GPD)	d/D
NODE 9 (3)	NODE 10	8	191,000	0.0052	2.5	2.3	564,339	373,339	0.40
NODE 10 (3)	NODE 11	8	239,000	0.0052	2.5	2.4	564,339	325,339	0.45
<b>Outfall to the Granite Ridge Sewer System to Happy Valley Road</b>									
Q (4)	AM	8	72,000	0.0052	2.5	1.7	564,339	492,339	0.24
AM	AN	8	175,000	0.0052	2.5	2.2	564,339	389,339	0.38
AN1 (5)	AN	8	94,000	0.0052	2.5	1.9	564,339	470,339	0.28
AN2 (6)	AN	8	166,000	0.0052	2.5	2.2	564,339	398,339	0.37
AN	A0	0	435,000	FM					
A0 (7)	AP	8	451,000	0.0052	2.5	2.8	564,339	113,339	0.68
AP	AQ	8	451,000	0.0052	2.5	2.8	564,339	113,339	0.68
AQ (8)	AR	8	454,000	0.0052	2.5	2.8	564,339	110,339	0.68
AR1	AR2	8	454,000	0.0055	2.6	2.8	580,390	126,390	0.67
AR2 (8)	AR3	8	455,000	0.0064	2.8	3.0	626,078	171,078	0.63
AR3	AR4	8	455,000	0.0442	7.3	6.2	1,645,318	1,190,318	0.36
AR4 (8)	AR5	8	462,000	0.0055	2.6	2.9	580,390	118,390	0.67
AR5 (8)	AR6	8	463,000	0.0055	2.6	2.9	580,390	117,390	0.68
AR6	AS	8	463,000	0.0056	2.6	2.9	585,643	122,643	0.67
AS (9)	AT	8	469,000	0.0129	3.9	4.0	888,860	419,860	0.52
AT	AU	8	469,000	0.0126	3.9	4.0	878,464	409,464	0.52
AU (10)	AV	8	481,000	0.0208	5.0	4.8	1,128,679	647,679	0.46
AV	AW	8	491,000	0.0420	7.1	6.2	1,603,849	1,112,849	0.38
AW	AX	8	496,000	0.0449	7.4	6.4	1,658,295	1,162,295	0.37
AX	AY	8	499,000	0.0060	2.7	3.0	606,198	107,198	0.69
AY	AZ	8	500,000	0.0227	5.2	5.0	1,179,103	679,103	0.45
AZ (11)	AA1	8	515,000	0.0296	6.0	5.6	1,346,433	831,433	0.43
AA1 (12)	AA2	8	547,000	0.0238	5.4	5.2	1,207,333	660,333	0.47
AA2 (13)	AA3	8	551,000	0.0282	5.8	5.6	1,314,206	763,206	0.45
AA3 (14)	AA4	8	561,000	0.0164	4.4	4.6	1,002,214	441,214	0.53
AA4 (15)	AA5	8	563,000	0.0351	6.5	6.1	1,466,197	903,197	0.43
AA5 (16)	AA6	8	577,000	0.0226	5.2	5.2	1,176,503	599,503	0.49
AA6	Ex. MH	8	577,000	0.0040	2.2	2.4	494,958	-82,042	0.94

**Ultimate Condition Sewage Pump Specifications**

		<b>PERFORMANCE CURVE</b>		PRODUCT	TYPE
DATE 2005-04-07		PROJECT Mcdowell Mountain Lift Station,		CURVE NO 63-488-00-3755	HT
1/1-LOAD	3/4-LOAD	1/2-LOAD	RATED POWER ....	IMPELLER DIAMETER	
0.89	0.87	0.81	10 hp	215 mm	
EFFICIENCY	83.5 %	85.0 %	STARTING CURRENT ...	MOTOR #	STATOR REV
MOTOR DATA	---	---	128 A	21-12-4AL	12Y// 11
COMMENTS	INLET/OUTLET		RATED CURRENT ...	FREQ.	PHASES
	- /100 mm		25 A	60 Hz	3
	IMP. THROUGHLET		RATED SPEED ....	VOLTAGE	POLES
	---		1735 rpm	230 V	4
			TOT.MOM.OF INERTIA ...	GEARTYPE	RATIO
			0.054 kgm2	---	---
			NO. OF BLADES		
			2		

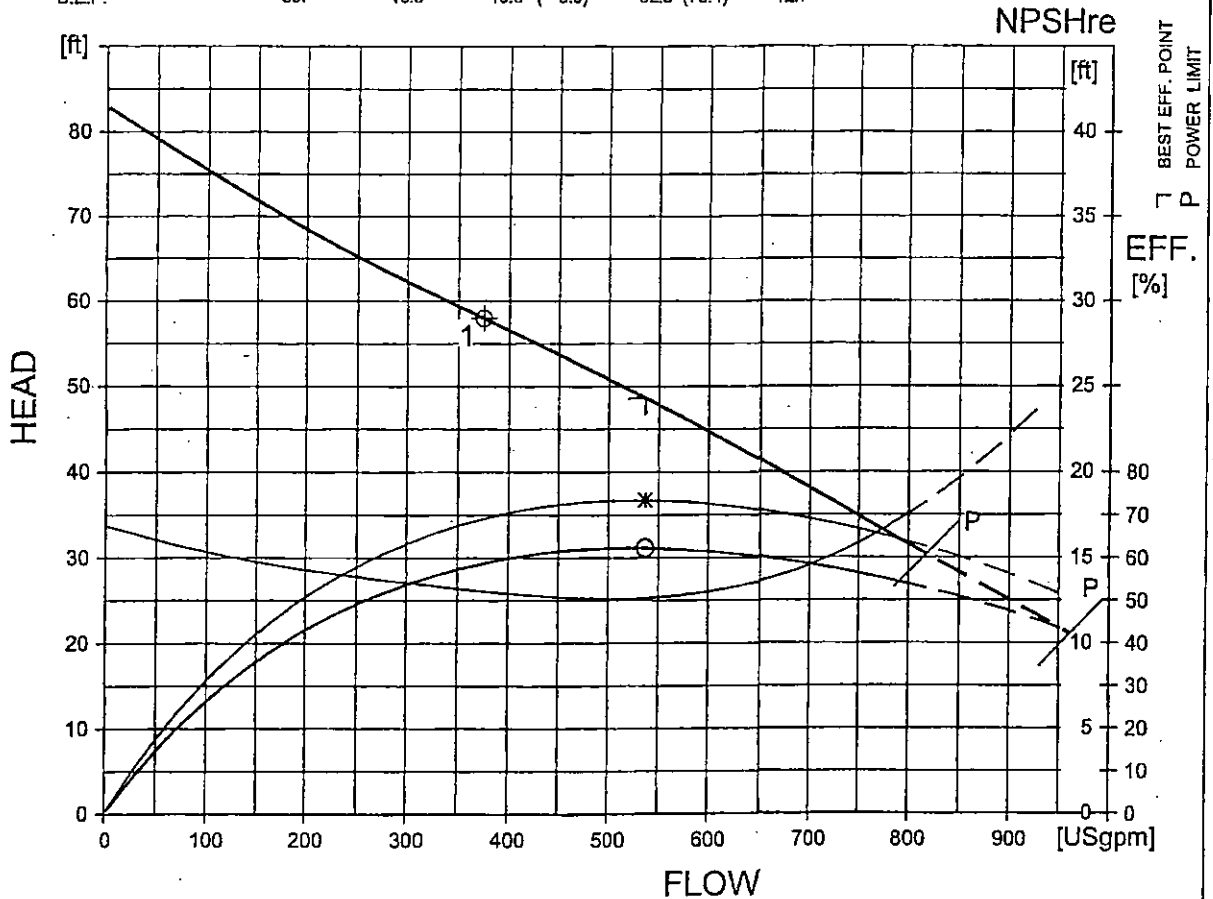
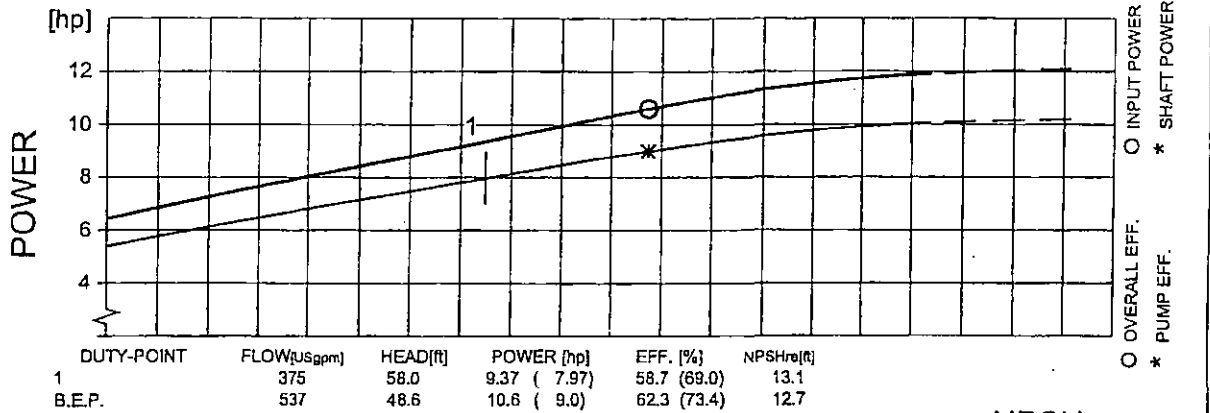

NPSHre = NPSH3% + min. operational margin  
 Performance with clear water and ambient temp 40 °C



**CURVE**

FLYPSZ.19 (20021016)

# N-3127

## Section 3



## Impeller/Motor/Nominal Sizes

Issued: 5/02

Supersedes: 8/00

PUMP MODEL	IMPELLER CODE	HP RATING				VAC	D1	D2	D3	D4
		NP	NS	NT	NZ					
3127 3Ø	421 LT	10.0	10.0	-	-	200 230/460 575	8"	6"	8"	-
	422 LT	7.5,10	7.5,10	7.4	7.4		8"	6"	8"	8"
	438 MT	10.0	10.0	-	-		4,6,8	4,6"	4,6"	6"
	439 MT	7.5,10	7.5,10	7.4	7.4		4,6,8	4,6"	4,6"	6"
	487 HT	10	10	-	-		4"	4"	4"	-
	488 HT	10	10	-	-		4"	4"	4"	-
	489 HT	7.5,10	7.5,10	7.4	7.4		4"	4"	4"	4"

PUMP MODEL	IMPELLER CODE	HP RATING				VAC	D1	D2	D3	D4
		NP	NS	NT	NZ					
3127 1Ø	422 LT	7.5	7.5	-	-	230	8"	6"	8"	-
	439 MT	7.5	7.5	-	-		4,6,8	4,6"	4,6"	-
	489 HT	7.5	7.5	-	-		4"	4"	4"	-

LT= High Volume MT= Standard HT= High Head

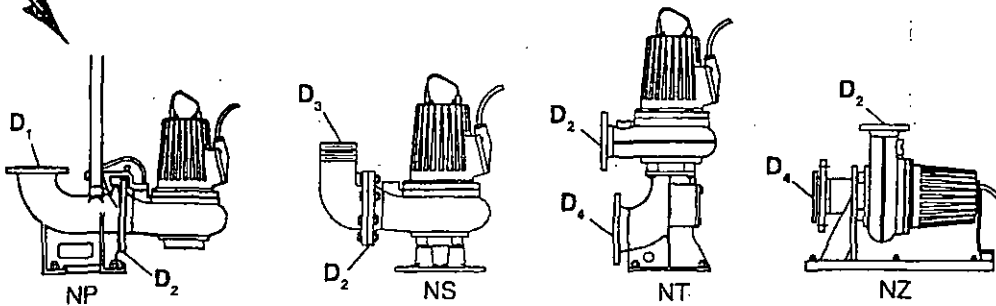

# CP/NP-3127

Section 4



Outline Dimensions

Issued: 8/02

Supersedes: 11/00

D0235

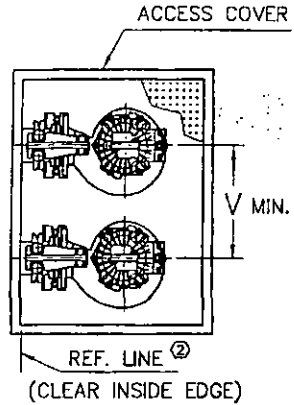
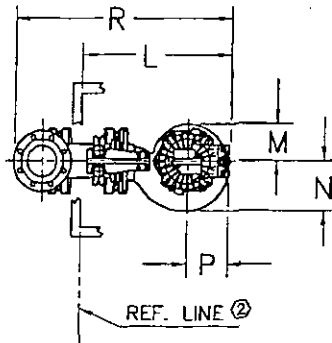

2" GUIDE BAR (2x)  
(SCHEDULE 40 PIPE)  
(NOT BY ITT FLYGT, CUT  
TO LENGTH AT ASS'Y)

STD. CLASS 125  
C.I. FLANGE  
(NOM. SIZE)

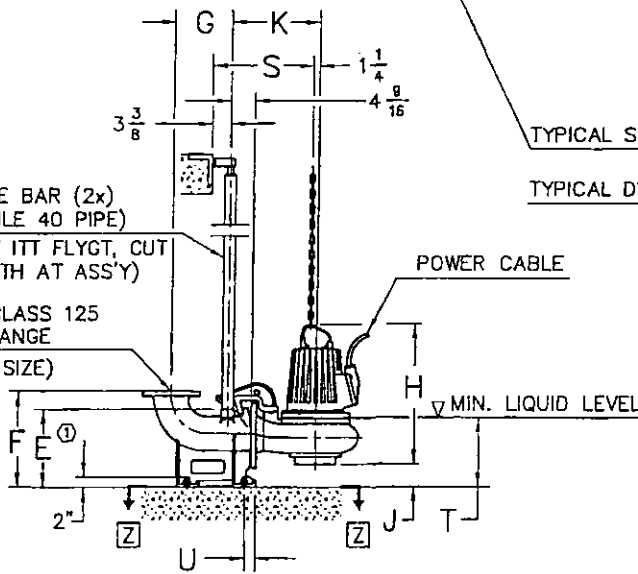

○ NOTES:

1. DIM. TO ENDS OF GUIDE BARS.
2. REPRESENTS CLEAR INSIDE EDGE OF ACCESS FRAME OR OPENING.
3. SEE STATION DWG. FOR COMPLETE INSTALLATION DIMENSIONS.

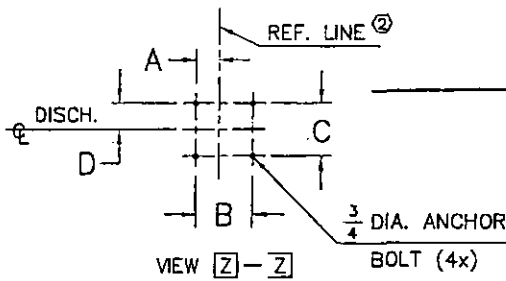

NOM. SIZE	TYPE	VERSION	WEIGHT(LBS)		
			PUMP	DISCH	
3"	CP	SH	325	80	
4"	CP/NP	HT	325	80	
4"	CP/NP	MT	340	80	
*	6"	CP/NP	MT	340	120
**	6"	CP/NP	MT	340	120
8"	CP/NP	LT	325	145	
8"	CP/NP	MT	315	145	

\* WITH 4" DIA. INLET  
\*\* WITH 6" DIA. INLET

ALL DIMENSIONS IN INCHES

TYPE	NOM. SIZE	VERSION	DIMENSIONAL CHART																		
			A	B	C	D	E	F	G	H	J	K	L	M	N	P	R	S	T	U	V
CP	3"	SH	2 1/2	10	8	4	10 3/4	15 3/4	9 1/2	24 1/4	3 1/2	16 3/4	28 1/2	6 1/2	7 1/4	8 1/4	38 1/2	19	11	2 3/4	17
CP/NP	4"	HT	2 3/4	10	8	4	10 1/4	15 3/4	10	25	3 1/4	16 3/4	28 1/2	7 3/4	9 1/4	8 1/4	39 1/2	19	11	2 3/4	20
CP/NP	4"	MT	2 3/4	10	8	4	10 1/4	15 3/4	10	26	3	16 3/4	28 1/2	7 1/4	8 1/2	8 1/4	39 1/2	19	12	2 3/4	20
*	6"	MT	4 1/4	11	10	5	14 1/2	17 3/4	11	26	5 3/4	16 3/4	28 1/2	8 1/2	8 1/2	8	41 1/2	19	15	2 1/4	22
**	6"	MT	4 1/4	11	10	5	14 1/2	17 3/4	11	26	4 1/4	16 3/4	28 1/2	7 1/4	8 1/2	8 1/4	41 1/2	19	13	2 1/4	22
CP/NP	8"	LT	5 1/2	11	10	5	15	17 3/4	12 1/4	26 3/4	4 1/4	18 1/2	30 1/4	7 1/4	10	8 1/2	45 1/2	20 1/2	14	2 1/4	22
CP/NP	8"	MT	5 1/2	11	10	5	15	17 3/4	12 1/4	26	4 1/4	16 3/4	28 1/2	7 1/4	8 1/2	8 1/4	44	19	13	2 1/4	22

# C/N-3127

**Section 6**



**Electrical Data**

Issued: 8/02

Supersedes: 7/02

### Motor Data

RATED OUTPUT POWER HP (kW)	Ø	VOLTS NOM.	FULL LOAD AMPS	LOCKED ROTOR AMPS	LOCKED ROTOR KVA	LOCKED ROTOR CODE LETTER KVA/HP	RATED INPUT POWER kW	POLES/RPM
10.0 (7.5)	3	200	29.0	173	60	G	8.9	4/1745
		230	26.0	150				
		460	13.0	75				
		575	10.0	60				
11.0 (8.2)	3	200	30.0	258	89	K	9.8	2/3495
		230	26.0	192	76	H		
		460	13.0	96	76	H		
		575	11.0	85	85	J		

PUMP MOTOR HP	EFFICIENCY			POWER FACTOR		
	100% LOAD	75% LOAD	50% LOAD	100% LOAD	75% LOAD	50% LOAD
10.0	84.0	85.0	84.0	0.87	0.85	0.77
11.0	83.5	84.0	82.5	0.93	0.92	0.88

### Cable Data

HP	VOLTS	MAX. LENGTH FT.	CABLE SIZE/ NOMINAL DIA.	CONDUCTORS (IN ONE CABLE)	PART NUMBER
10.0	200	165	8/3-2-1-GC 28.2mm (1.11")	(3) 8 AWG (PWR) (2) 10 AWG (CTRL) (1) 8 AWG (GND) (1) 10 AWG (GC)	94 21 08
10.0	230	135	10/3-2-1-GC 21.3mm (0.84")	(3) 10 AWG (PWR) (2) 12 AWG (CTRL) (1) 10 AWG (GND) (1) 12 AWG (GC)	94 21 06
	460	535			
	575	870			
11.0	200	150	8/3-2-1-GC 28.2mm (1.11")	(3) 8 AWG (PWR) (2) 10 AWG (CTRL) (1) 8 AWG (GND) (1) 10 AWG (GC)	94 21 08
	230	200			
	460	795			
	575	1,175			

# C/N-3127

Section 7



Performance Specifications

Issued: 9/00

Supersedes: 5/97

## REQUIREMENTS

Furnish and install \_\_\_ submersible non-clog wastewater pump(s). Each pump shall be equipped with an \_\_\_ HP submersible electric motor connected for operation on \_\_\_ volts, \_\_\_ phase, 60 hertz, \_\_\_ wire service, with \_\_\_ feet of submersible cable (SUBCAB) suitable for submersible pump applications. The power cable shall be sized according to NEC and ICEA standards and have P-MSHA Approval. The pump shall be supplied with a mating cast iron \_\_\_ inch discharge connection and be capable of delivering \_\_\_ GPM at \_\_\_ TDH. An additional point on the same curve shall be \_\_\_ GPM at \_\_\_ feet total head. Shut off head shall be \_\_\_ feet (minimum). Each pump shall be fitted with \_\_\_ feet of \_\_\_ lifting chain or stainless steel cable. The working load of the lifting system shall be 50% greater than the pump unit weight.

## PUMP DESIGN

The pump(s) shall be automatically and firmly connected to the discharge connection, guided by no less than two guide bars extending from the top of the station to the discharge connection. There shall be no need for personnel to enter the wet-well. Sealing of the pumping unit to the discharge connection shall be accomplished by a machined metal to metal watertight contact. **Sealing of the discharge interface with a diaphragm, O-ring or profile gasket will not be acceptable.** No portion of the pump shall bear directly on the sump floor.

## PUMP CONSTRUCTION

Major pump components shall be of grey cast iron, ASTM A-48, Class 35B, with smooth surfaces devoid of blow holes or other irregularities. All exposed nuts or bolts shall be AISI type 304 stainless steel construction. All metal surfaces coming into contact with the pumpage, other than stainless steel or brass, shall be protected by a factory applied spray coating of acrylic dispersion zinc phosphate primer with a polyester resin paint finish on the exterior of the pump.

Sealing design shall incorporate **metal-to-metal contact** between machined surfaces. Critical mating surfaces where watertight sealing is required shall be machined and fitted with Nitrile or Viton rubber O-rings. Fittings will be the result of controlled compression of rubber O-rings in two planes and O-ring contact of four sides without the requirement of a specific torque limit.

Rectangular cross sectioned gaskets requiring specific torque limits to achieve compression shall not be

considered as adequate or equal. No secondary sealing compounds, elliptical O-rings, grease or other devices shall be used.

## COOLING SYSTEM

Motors are sufficiently cooled by the surrounding environment or pumped media. A water jacket is not required.

## CABLE ENTRY SEAL

The cable entry seal design shall preclude specific torque requirements to insure a watertight and submersible seal. The cable entry shall consist of a single cylindrical elastomer grommet, flanked by washers, all having a close tolerance fit against the cable outside diameter and the entry inside diameter and compressed by the body containing a strain relief function, separate from the function of sealing the cable. The assembly shall provide ease of changing the cable when necessary using the same entry seal. **The cable entry junction chamber and motor shall be separated by a stator lead sealing gland or terminal board, which shall isolate the interior from foreign material gaining access through the pump top. Epoxies, silicones, or other secondary sealing systems shall not be considered acceptable.**

## MOTOR

The pump motor shall be a NEMA B design, induction type with a squirrel cage rotor, shell type design, housed in an air filled, watertight chamber. The stator windings shall be insulated with moisture resistant Class H insulation rated for 180°C (356°F). The stator shall be insulated by the trickle impregnation method using Class H monomer-free polyester resin resulting in a winding fill factor of at least 95%. The stator shall be heat-shrink fitted into the cast iron stator housing. The use of multiple step dip and bake-type stator insulation process is not acceptable. The use of bolts, pins or other fastening devices requiring penetration of the stator housing is not acceptable. The motor shall be designed for continuous duty handling pumped media of 40°C (104°F) and capable of up to 15 evenly spaced starts per hour. The rotor bars and short circuit rings shall be made of cast aluminum. Thermal switches set to open at 125°C (260°F) shall be embedded in the stator lead coils to monitor the temperature of each phase winding. These thermal switches shall be used in conjunction with and supplemental to external motor overload protection and shall be connected to the control panel. The junction chamber containing the terminal board, shall be hermetically sealed from the



# C/N-3127

## Section 7



## Performance Specifications

Issued: 9/00

Supersedes: 5/97

motor by an elastomer compression seal. Connection between the cable conductors and stator leads shall be made with threaded compression type binding posts permanently affixed to a terminal board. The motor and the pump shall be produced by the same manufacturer.

The combined service factor (combined effect of voltage, frequency and specific gravity) shall be a minimum of 1.15. The motor shall have a voltage tolerance of plus or minus 10%. The motor shall be designed for operation up to 40°C (104°F) ambient and with a temperature rise not to exceed 80°C. A performance chart shall be provided upon request showing curves for torque, current, power factor, input/output kW and efficiency. This chart shall also include data on starting and no-load characteristics.

The power cable shall be sized according to the NEC and ICEA standards and shall be of sufficient length to reach the junction box without the need of any splices. The outer jacket of the cable shall be oil resistant chloroprene rubber. The motor and cable shall be capable of continuous submergence underwater without loss of watertight integrity to a depth of 65 feet.

The motor horsepower shall be adequate so that the pump is non-overloading throughout the entire pump performance curve from shut-off through run-out.

### BEARINGS

The pump shaft shall rotate on two bearings. Motor bearings shall be permanently grease lubricated. The upper bearing shall be a single deep groove ball bearing. The lower bearing shall be a two row angular contact bearing to compensate for axial thrust and radial forces. **Single row lower bearings are not acceptable.**

### MECHANICAL SEAL

Each pump shall be provided with a tandem mechanical shaft seal system consisting of two totally independent seal assemblies. The seals shall operate in an lubricant reservoir that hydrodynamically lubricates the lapped seal faces at a constant rate. The lower, primary seal unit, located between the pump and the lubricant chamber, shall contain one stationary and one positively driven rotating, corrosion resistant tungsten-carbide ring. The upper, secondary seal unit, located between the lubricant chamber and the motor housing, shall contain one stationary and one positively driven rotating, corrosion resistant tungsten-carbide seal ring. Each seal interface shall be held in contact by its own spring

system. The seals shall require neither maintenance nor adjustment nor **depend on direction of rotation for sealing.** The position of both mechanical seals shall depend on the shaft. Mounting of the lower mechanical seal on the impeller hub will not be acceptable. For special applications, other seal face materials shall be available.

**The following seal types shall not be considered acceptable nor equal to the dual independent seal specified:** shaft seals without positively driven rotating members, or conventional double mechanical seals containing either a common single or double spring acting between the upper and lower seal faces. No system requiring a pressure differential to offset pressure and to effect sealing shall be used.

Each pump shall be provided with an lubricant chamber for the shaft sealing system. The lubricant chamber shall be designed to prevent overfilling and to provide lubricant expansion capacity. The drain and inspection plug, with positive anti-leak seal shall be easily accessible from the outside. The seal system shall not rely upon the pumped media for lubrication. **The motor shall be able to operate dry without damage while pumping under load.**

**Seal lubricant shall be FDA Approved, nontoxic.**

### PUMP SHAFT

Pump and motor shaft shall be the same unit. The pump shaft is an extension of the motor shaft. Couplings shall not be acceptable. The shaft shall be AISI type 431 stainless steel.

If a shaft material of lower quality than 431 stainless steel is used, a shaft sleeve of 431 stainless steel is used to protect the shaft material. However, shaft sleeves only protect the shaft around the lower mechanical seal. No protection is provided in the oil housing and above. Therefore, the use of stainless steel sleeves will not be considered equal to stainless steel shafts.

### IMPELLER (for C - pumps)

The impeller(s) shall be of gray cast iron, Class 35B, dynamically balanced, double shrouded non-clogging design having a long throughlet without acute turns. The impeller(s) shall be capable of handling solids, fibrous materials, heavy sludge and other matter found in wastewater. Whenever possible, a full vaned, not vortex, impeller shall be used for maximum hydraulic efficiency; thus, reducing operating costs. Mass

# C/N-3127

## Section 7



## Performance Specifications

Issued: 9/00

Supersedes: 5/97

moment of inertia calculations shall be provided by the pump manufacturer upon request. Impeller(s) shall be keyed to the shaft, retained with an Allen head bolt and shall be capable of passing a minimum \_\_\_\_ inch diameter solid. All impellers shall be coated with an acrylic dispersion zinc phosphate primer.

### WEAR RINGS (for C - pumps)

A wear ring system shall be used to provide efficient sealing between the volute and suction inlet of the impeller. Each pump shall be equipped with a brass, or nitrile rubber coated steel ring insert that is drive fitted to the volute inlet.

### VOLUTE (for C - pumps)

Pump volute(s) shall be single-piece grey cast iron, Class 35B, non-concentric design with smooth passages large enough to pass any solids that may enter the impeller. Minimum inlet and discharge size shall be as specified.

### IMPELLER (for N - pumps)

The impeller(s) shall be of gray cast iron, Class 35B, dynamically balanced, semi-open, multi-vane, back-swept, non-clog design. The impeller vane leading edges shall be mechanically self-cleaned upon each rotation as they pass across a spiral groove located on the volute suction which shall keep them clear of debris, maintaining an unobstructed leading edge. The impeller(s) vanes shall have screw-shaped leading edges that are hardened to Rc 45 and shall be capable of handling solids, fibrous materials, heavy sludge and other matter found in waste water. The screw shape of the impeller inlet shall provide an inducing effect for the handling of sludge and rag-laden wastewater. Impellers shall be locked to the shaft and shall be coated with alkyd resin primer.

### VOLUTE BOTTOM/INSERT RING (for N - pumps)

The pump volute shall be of A48 Class 35B gray cast iron and shall have (an) integral spiral shaped cast groove(s) at the suction of the volute. The internal volute bottom or insert ring shall provide effective sealing between the pump volute and the multi-vane, semi-open impeller. The sharp spiral groove(s) shall provide the shearing edge(s) across which each impeller vane leading edge shall cross during its rotation in order to remain unobstructed. The clearance between the internal volute bottom and the impeller leading edges shall be adjustable.

### PROTECTION

All stators shall incorporate thermal switches in series to monitor the temperature of each phase winding. The thermal switches shall open at 125°C (260°F), stop the motor and activate an alarm.

A leakage sensor shall be available as an option to detect water in the stator chamber. The Float Leakage Sensor (FLS) is a small float switch used to detect the presence of water in the stator chamber. When activated, the FLS will stop the motor and send an alarm both local and/or remote. **USE OF VOLTAGE SENSITIVE SOLID STATE SENSORS AND TRIP TEMPERATURE ABOVE 125°C (260°F) SHALL NOT BE ALLOWED.**

The thermal switches and FLS shall be connected to a Mini CAS (Control and Status) monitoring unit. The Mini CAS shall be designed to be mounted in any control panel.

Note: FLS not available in CZ/NZ Configuration.

### MODIFICATIONS

1. Explosion-proof Pumps (X).
2. Warm Liquid Applications (WL).
3. Dry Pit Installations (CT).

Refer to the General Guide Specifications for additional information.

C-3127

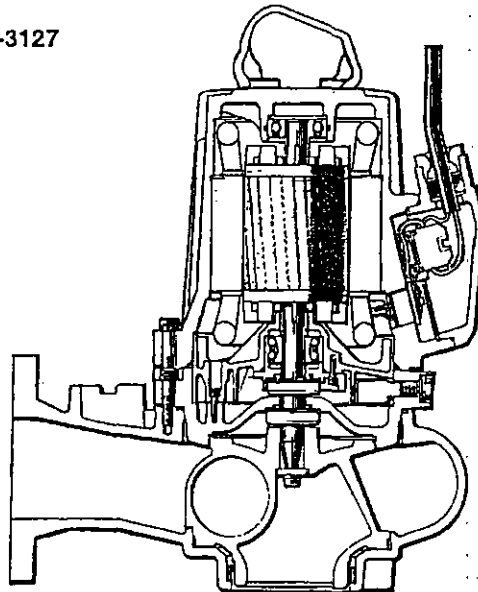

# General Guide Specifications

Section 7



Issued: 5/97

Supersedes: 5/96

## GENERAL

The general guide specifications is intended to cover the items applying to all Flygt pumps for this project. Pump specifications follow the general section. Thus; Quality, Technical Support, Testing, and Experience apply to all Flygt pumps for this project.

## SCOPE

The specifications shall govern all work necessary to furnish, install and place into operation the electrical submersible pump(s) required to complete this project. This section includes electric submersible pump(s) to be supplied with motor, close coupled volute, cast iron discharge elbow, guide bar brackets, power cable and accessories. The pumps are available for wet pit (CP), dry pit (CT) and portable (CS) installations.

## QUALITY ASSURANCE

The pump(s) shall be heavy duty, electric submersible, centrifugal non-clog units designed for handling raw, unscreened sewage and wastewater and shall be fully guaranteed for this use. The pumps provided shall be capable of operating in an ambient liquid temperature of 104°F. Since the high temperature of 104°F is specified by the National Electrical Manufacturers Association (NEMA) and Factory Mutual (FM), motors with a maximum ambient temperature rating below 104°F shall not be acceptable.

The pump and motor unit shall be suitable for continuous operation at full nameplate load while the motor is completely submerged, partially submerged or totally non-submerged. The use of shower systems, secondary pumps or cooling fans to cool the motor shall not be acceptable.

The pump, mechanical seals and motor units provided under this specification shall be from the same manufacturer in order to achieve standardization of operation, maintenance, spare parts, manufacturer's service and warranty.

## SUBMITTALS

Submittal data shall be provided to show compliance with these specifications, plans or other specifications that will influence the proper operation of the pump(s).

Standard submittal data for approval must consist of:

- a. Pump Performance Curves.
- b. Pump Outline Drawing.
- c. Station Drawing for Accessories.
- d. Electrical Motor Data.
- e. Control Drawing and Data.
- f. Access Frame Drawing.
- g. Typical Installation Guides.
- h. Technical Manuals.
- i. Parts List.
- j. Printed Warranty.
- k. Manufacturer's Equipment Storage Recommendations.
- l. Manufacturer's Standard Recommended Start-Up Report Form.

Lack of the above requested submittal data is cause for rejection.

## TESTING

Testing performed upon each pump shall include the following inspections:

- a. Impeller, motor rating and electrical connections shall be checked for compliance with this specification.
- b. Prior to submergence, each pump shall be run dry to establish correct rotation.
- c. Each pump shall be run submerged in water.
- d. Motor and cable insulation shall be tested for moisture content or insulation defects.

Upon request, a written quality assurance record confirming the above testing/inspections shall be supplied with each pump at the time of shipment.

Each pump (when specified) shall be tested in accordance with the latest test code of the Hydraulic Institute (HI) at the manufacturer to determine head vs. capacity and kilowatt draw required. Witness tests shall be available at the factory upon request.

The pump(s) shall be rejected if the above requirements are not satisfied.

## START-UP SERVICE

The equipment manufacturer shall furnish the services of a qualified factory trained field service engineer for 8-hour working day(s) at the site to inspect the installation and instruct the owner's personnel on the operation and maintenance of the pumping units. After the pumps have been completely installed and wired, the contractor shall have the manufacturer do the following:

# General Guide Specifications

Section 7



Issued: 5/97

Supersedes: 5/96

- a. Megger stator and power cables.
- b. Check seal lubrication.
- c. Check for proper rotation.
- d. Check power supply voltage.
- e. Measure motor operating load and no load current.
- f. Check level control operation and sequence.

During this initial inspection, the manufacturer's service representative shall review recommended operation and maintenance procedures with the owner's personnel.

## FACTORY SERVICE

Factory-Approved service facilities with qualified factory-trained mechanics shall be available for prompt emergency and routine service.

## GUARANTEE

See *individual market sector Warranty Policies* as presented in section 1 of this catalog.

*The warranty shall be in printed form and previously published as the manufacturer's standard warranty for all similar units manufactured.*

## EXPERIENCE

The pump manufacturer shall have a minimum of 10,000 heavy-duty submersible wastewater pumps installed and operating for no less than 5 years in the United States.

## MANUFACTURERS

- a. The pump, mechanical seals and motor shall be from the same manufacturer.
- b. The pump, mechanical seals and motor manufacturer shall be Flygt.

## MODIFICATIONS:

### a. EXPLOSION-PROOF PUMPS (X):

The pump system including the pump, motor and power cable shall be approved for use in areas classified as hazardous locations in accordance with the NEC Class I, Div. 1, Group C and D service as determined and approved by a U.S. nationally recognized testing laboratory (U.L., FM, CSA) at the time of the bidding of the project. As required by Factory Mutual (FM) the motor shall be capable of operating in pumped media up to 104°F. Motor

thermal switches shall monitor and protect the motor from excessive temperature. An internal Float Switch shall be available, as an option, in the motor chamber. Service of explosion-proof submersible units shall be performed by qualified FM experienced personnel. **The pump manufacturer must provide training schools to qualify personnel in the proper service and repair of explosion-proof pumps.**

### b. DRY PIT INSTALLATION (CT):

Motor cooling shall be sufficient for continuous operation under full nameplate load in a dry environment. The pump(s) shall be capable of handling pumped media up to 104°F.

**OIL FILLED MOTORS** - Since the complete motor requires total oil immersion for adequate heat dissipation, **oil filled motors shall not be considered for dry pit installations.**

### DRY TYPE - EXTERNAL FAN COOLED

**MOTORS** - When external fan cooling is required, two **Separate** motors are required one for the pump and one for the fan. This results in higher input power, increased operating costs and possible fan motor failure. A submersible pump is used for dry pit installation because of the high possibility of flooding. If the fan motor is operating when submerged, the down thrust developed will damage the fan motor. A pump motor of about **200 HP Depends** on the performance of a **3 HP** fan motor. **Thus, air cooled fans shall not be considered for dry pit installations.**

### c. WARM LIQUID APPLICATIONS (WL):

Higher temperature units shall be available for pumped media temperatures of 140°F, 160°F and 195°F. Alternative cable, O-rings, seal materials, etc. may be used for the higher temperature applications. *On certain pump models and for some higher temperatures, an external source of cooling water may be required.*

### d. STAINLESS STEEL PUMPS (SS):

Complete pump models shall be available in stainless steel. In addition, pump portions including impeller, volute, hydraulic end and motor shall be available in stainless steel. The pump models shall be capable of handling pumped media up to 104°F.

# TOP Fiberglass Basin 100/150

(Duplex DP-3067 thru CP-3152)

Section 10



Accessories

Issued: 11/00

Supersedes:

**NOTE:**

DISCHARGE CONNECTIONS ARE NOT SUPPLIED WITH TOP FIBERGLASS BASIN OR MOUNTING HARDWARE KIT. THEY MUST BE ORDERED SEPARATELY.

BASIN MODEL NO.	FIBERGLASS BASIN PART #	MOUNTING HARDWARE KIT
TOP 100	13-50 70 08	13-52 06 16
TOP 150	13-50 70 09	13-52 06 16

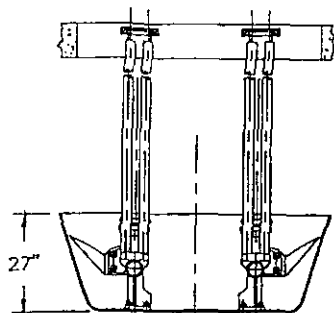

SECTION B-B

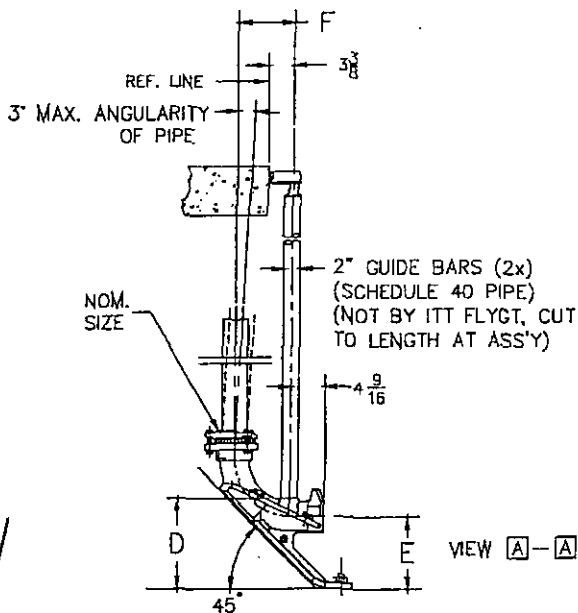
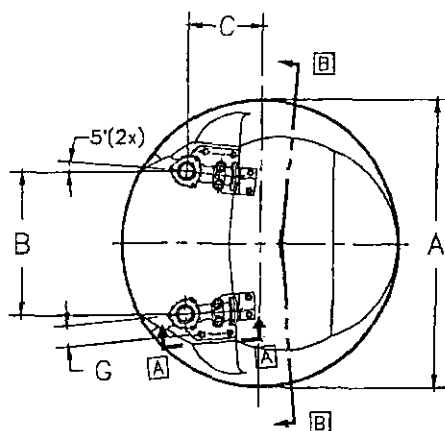

VIEW A-A

PUMP MODEL	NOMINAL SIZE	MODEL NO.		DIMENSIONAL CHART						
		100	150	A	B	C	D	E	F	G
DP 3067-MT	2-1/2"	X		59"	24"	17-1/2"	11	9"	7-1/2"	4-3/4"
CP 3075-MT	3"	X		59"	24"	17-1/2"	12	9-3/4"	7-1/2"	4-3/4"
CP 3085-HT	3"	X		59"	24"	17-1/2"	12	9-3/4"	7-1/2"	4-3/4"
CP 3085-MT	4"	X		59"	24"	17-1/2"	12-1/2"	9-3/4"	7-1/2"	4-3/4"
CP 3102-MT	4"	X		59"	24"	17-1/2"	12-1/2"	9-3/4"	7-1/2"	4-3/4"
CP 3102-MT	4"		X	67"	32"	17"	12-1/2"	9-3/4"	7-1/2"	4-3/4"
CP 3102-LT	6"		X	67"	30"	18-3/4"	15-3/4"	12"	9"	5-3/4"
CP 3127-HT	4"	X		59"	24"	17-1/2"	12-1/2"	9-3/4"	7-1/2"	4-3/4"
CP 3127-HT	4"		X	67"	32"	17"	12-1/2"	9-3/4"	7-1/2"	4-3/4"
CP 3127-MT	4"	X		59"	24"	17-1/2"	12-1/2"	9-3/4"	7-1/2"	4-3/4"
CP 3127-MT	4"		X	67"	32"	17"	12-1/2"	9-3/4"	7-1/2"	4-3/4"
CP 3127-MT	6"		X	67"	30"	18-3/4"	15-3/4"	12"	9"	5-3/4"
CP 3140-HT	4"	X		59"	24"	17-1/2"	12-1/2"	9-3/4"	7-1/2"	4-3/4"
CP 3140-HT	4"		X	67"	32"	17"	12-1/2"	9-3/4"	7-1/2"	4-3/4"
CP 3140-MT	6"		X	67"	30"	18-3/4"	15-3/4"	12"	9"	5-3/4"
CP 3152-HT	4"		X	67"	32"	17"	12-1/2"	9-3/4"	7-1/2"	4-3/4"
CP 3152-HT	6"		X	67"	30"	18-3/4"	15-3/4"	12"	9"	5-3/4"
CP 3152-MT	6"		X	67"	30"	18-3/4"	15-3/4"	12"	9"	5-3/4"

# TOP Fiberglass Basin 100/150 (Duplex Station)

(Fiberglass Basin - 3067 thru 3152)

Section 10



Accessories

Issued: 11/00

Supersedes:

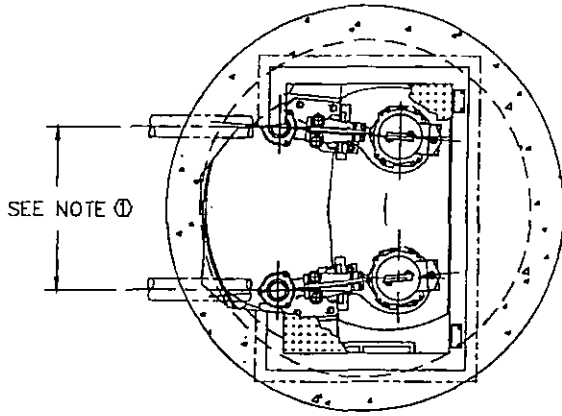

- NOTE:  
1. SEE OUTLINE DIMENSIONAL DRAWING OF TOP FIBERGLASS BASIN FOR DISTANCE BETWEEN DISCHARGE PIPES.

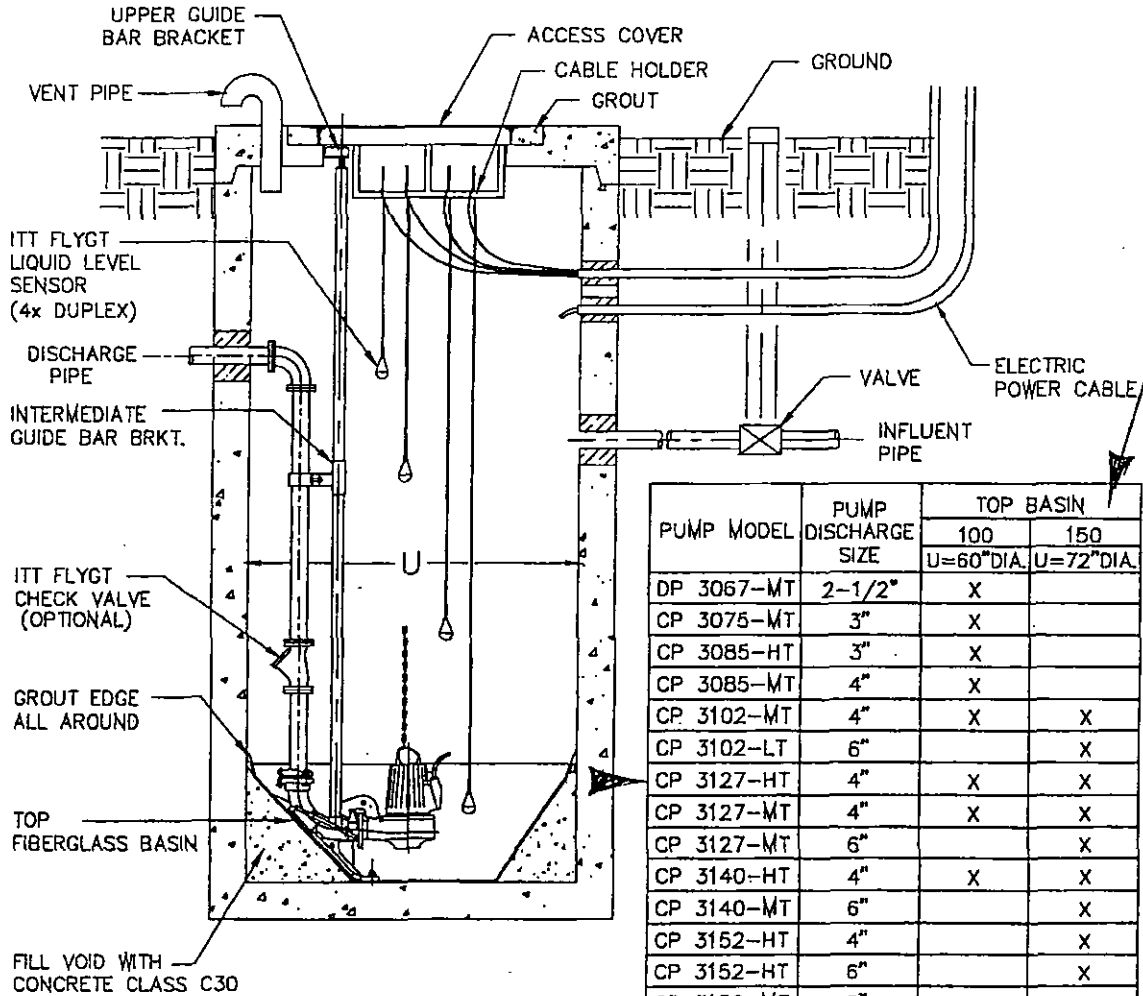

PUMP MODEL	PUMP DISCHARGE SIZE	TOP BASIN	
		100	150
DP 3067-MT	2-1/2"	X	
CP 3075-MT	3"	X	
CP 3085-HT	3"	X	
CP 3085-MT	4"	X	
CP 3102-MT	4"	X	X
CP 3102-LT	6"		X
CP 3127-HT	4"	X	X
CP 3127-MT	4"	X	X
CP 3127-MT	6"		X
CP 3140-HT	4"	X	X
CP 3140-MT	6"		X
CP 3152-HT	4"		X
CP 3152-HT	6"		X
CP 3152-MT	6"		X

**Ultimate Condition Wet Well Calculations**

Project: SERENO CANYON Project Number: 042054.15  
 Location: City of Scottsdale Project Engineer: Gordon Wark, P.E.  
 Date: 10/31/2005  
 References: City of Scottsdale Design Standards  
 ADEQ Bulletin No. 11  
 Second Amended Wastewater System Study

**Fixed Parameters**

PARAMETER	VALUE	UNITS	NOTES
Maximum Retention Time	30	Min.	Max. time without odor control.
Minimum Pump Cycle Time**	10	Min.	
Wet Well Inside Diameter	6	Ft.	
Wet Well Base Elevation	2623	Ft.	
Finish Grade Elevation	2640	Ft.	
Wet Well Depth	17	Ft.	
Influent Line Invert Elevation	2630	Ft.	
Wet Well X-sectional Area	28.3	Ft <sup>2</sup>	
Pump Operating Capacity	375.0	GPM	

**Design Parameters**

PARAMETER	VALUE	UNITS	NOTES
<b>General:</b>			
Alarm Elevation	2629	Ft.	
High-High Water Elevation	2628	Ft.	(Both Pumps On)
High Water Elevation	2627	Ft.	(Pump On)
Low Water Elevation	2624	Ft.	(Pump Off)
Working Depth	3.0	Ft.	= High Water Elevation - Low Water Elevation
Wet Well Retention Depth	7.0	Ft.	= Influent Line Invert Elev. - Wet Well Base Elevation
Minimum Wet Well Volume Req't	938	Gal.	= .25 * Min. Pump Cycle Time * Pump Capacity per R18 Requirement
Wet Well Retention Volume	1480	Gal.	= Wet Well Retention Depth * X-Sectional Area * 7.48 gal/ft3
Wet Well Retention Time - Pump Failure Event	0.33	Hours	= Wet Well Retention Vol / ADWF / 60
<b>Average Daily Flow Rates:</b>			
ADWF Influent Rate	108,750	GPD	
	76	GPM	
Net Flowrate Out	299	GPM	= Pump Capacity - ADWF Influent Rate
Wet Well Working Volume	634	Gal.	= ((High water elev. - Low water elev.)*Wet Well X-Sectional Area)*7.48
Actual Pump On Time	2.1	Min.	= Wet Well Working Volume / Net Flow Rate Out
Actual Pump Off Time	8.4	Min.	= Wet Well Working Volume / ADWF Influent Rate
(ADWF Retention Time) Cycle Time*	10.5	Min.	= Pump On Time + Pump Off Time
<b>Max Daily Flow Rates:</b>			
Max Daily Influent Rate	435,000	GPD	
Max Daily Influent Rate	302	GPM	
Net Flowrate Out	73	GPM	= Pump Capacity - Max Daily Influent Rate
Wet Well Working Volume	634	Gal.	= ((High water elev. - Low water elev.)*Wet Well X-Sectional Area)*7.48
Actual Pump On Time	8.7	Min.	= Wet Well Working Volume / Net Flow Rate Out
Actual Pump Off Time	2.1	Min.	= Wet Well Working Volume / ADWF Influent Rate
(ADWF Retention Time) Cycle Time*	10.8	Min.	= Pump On Time + Pump Off Time

\*Cycle times shown are for single-pump operation. The design is intended for pumps to operate in a lead-lag scenario, alternating after each cycle.

\*\*Cycle times for single-pump operation assume the pumps run in a lead-lag configuration. According to the Flygt Pump representative, Flygt pump motors can withstand cycle times as low as or lower than 2 minutes on an occasional basis to accommodate scenarios such as swimming pool drainage.



**Ultimate Condition Force Main Calculations**

# WOOD/PATEL

CIVIL ENGINEERS \* HYDROLOGISTS \* LAND SURVEYORS \* CONSTRUCTION MANAGERS

## Force Main Calculations

Project: Master Wastewater Plan for Sereno Canyon

Location: Scottsdale, Arizona

Date: October 31, 2005

References: City of Scottsdale Design Standards and Policies Manual

Project Number: 042054.15

References: Hazen-Williams formula

Project Engineer: Gordon Wark, P.E.

### Known Values:

Hazen-Williams coefficient, C =	120	DIP Force Main, "C" = 120
Initial Elevation (low water elevation in wet well)=	2,622	located at proposed sewage pumping station
Final Elevation =	2,655	Existing Stub of Granite Ridge Gravity Sewer System
Forcemain Length (ft) =	5,030	
Minor Loss Equivalent Length (10% of Length) =	503	

### Calculated Values:

Referenced Equations:

$$v = Q / A \quad (1 \text{ cfs} = 449 \text{ gpm})$$

$$A = \pi * [(D / 12) ^2] / 4$$

$$H_f = 3022 * [(v / C) ^1.85] / [(D / 12) ^1.165]$$

where: v = velocity, feet per second (fps)

Q = flow rate, gallons per minute (gpm)

A = conveyance area, square feet

D = inside pipe diameter, inches

H<sub>f</sub> = head loss, feet per thousand feet of pipe

Peak Flow (gpm)	Peak Flow (gpd)	Pipe Dia. (in.)	Velocity (fps)	Head Loss per 1,000 ft (ft)	Total Friction Head Loss (ft)	Total Dynamic Head Loss (ft)	Pressure Loss (psi)
120.0	172,800	4	3.06	12.28	17.0	50.0	22
130.0	187,200	4	3.32	14.24	18.4	51.4	22
140.0	201,600	4	3.57	16.33	19.8	52.8	23
150.0	216,000	4	3.83	18.56	21.2	54.2	23
160.0	230,400	4	4.08	20.91	22.6	55.6	24
170.0	244,800	4	4.34	23.39	24.0	57.0	25
187.5	270,000	4	4.79	28.04	26.5	59.5	26

Pump Operating Point

### Notes:

- 1) The velocity and head loss calculations are based on the peak flow rate. The pump capacity should be used for the actual flow rate during the final lift station design.
- 2) Wet well sizing, pump cycling and pump discharge rates would be designed such that the minimum flow velocity in the forcemain is not less than 4 fps.
- 4) For higher-velocity force mains, it may be required to increase the size of the forcemain prior to discharging to a manhole, etc. in order to reduce the discharge velocity.
- 5) Surge calculations should be performed to ensure that the proper pipe class is being used.
- 6) When wastewater is pumped over a considerable distance, increasing the forcemain size may reduce horsepower requirements (and operation & maintenance costs) of the lift station pumps, due to reduced friction

**APPENDIX E**

**References**

# WOOD/PATEL

CIVIL ENGINEERS \* HYDROLOGISTS \* LAND SURVEYORS \* CONSTRUCTION MANAGERS

## References

Project: Master Wastewater Plan for Sereno Canyon Project Number: 042054.06  
Location: Scottsdale, Arizona Project Engineer: Tim Huval, P.E.  
Date: September 26, 2005  
References: City of Scottsdale Design Standards and Policies Manual

Land Use	Average Day Flow	Type	Pipe Size (IN)	Min Slope (FT/FT)	Design Flow (GPCD)	Peaking Factor	Manhole Spacing
Residential	250 gpd/DU	Residential	8	0.00520	100	4	500
Commercial	0.90 gpd/sf	Commercial	10	0.00400	100	4	500
General Office	0.50 gpd/sf	Retail	12	0.00300	100	4	500
Hotel	402 gpd/room	Resort	15	0.00220	105	Harmons	500
		Cultural/Institutional			105	Harmons	600
					105	Harmons	600
					105	Harmons	600

Minimum Pipe Velocity 2.5 FPS  
Maximum Pipe Velocity 10 FPS

Source: ADEQ Bulletin

**PLATE 1**

**Vicinity Map**

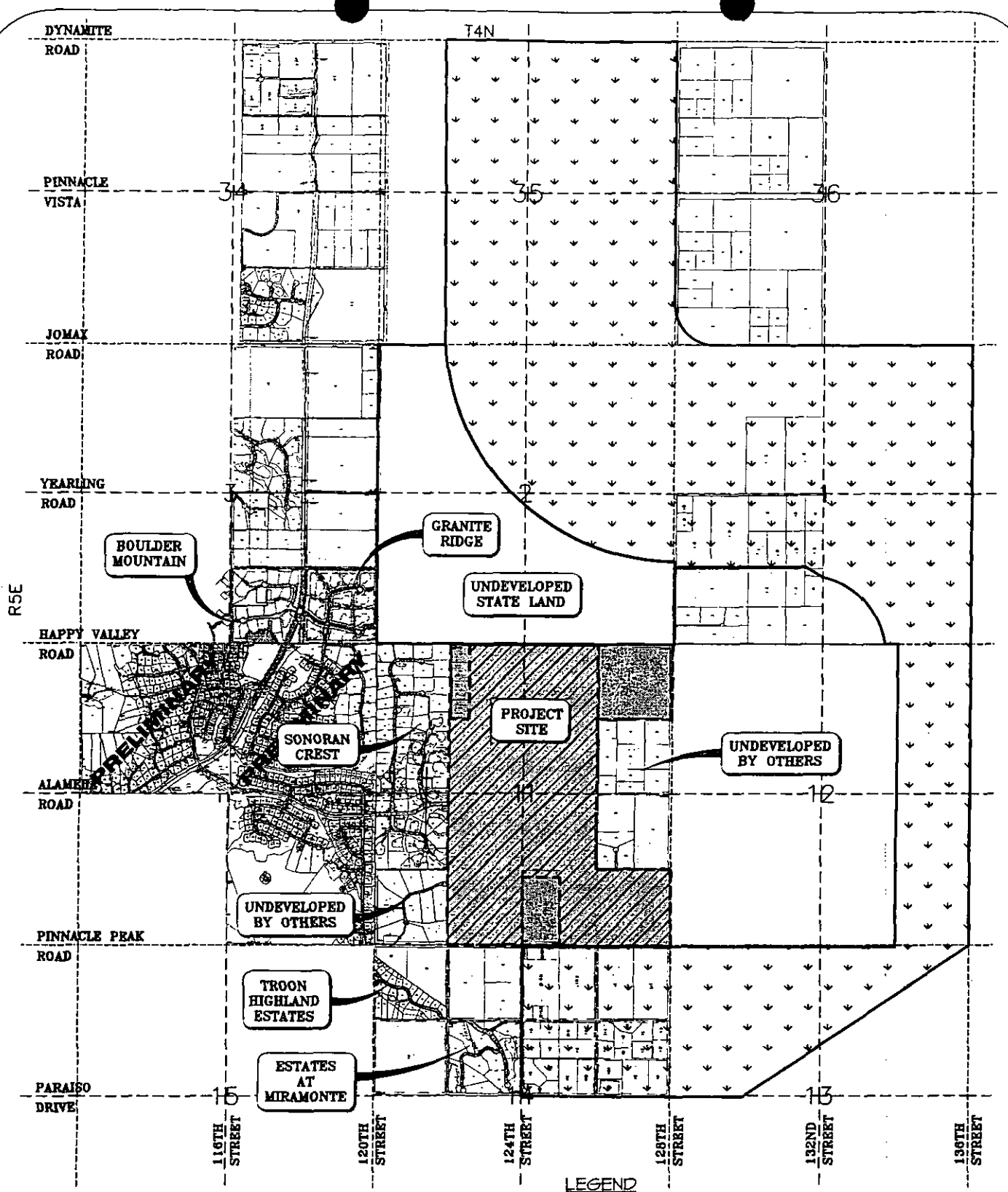

**LEGEND**

- - - Project Boundary
- [Hatched Box] Project Site - Option 1
- [Dotted Box] Project Site - Option 2
- [Arrow Pattern Box] McDowell Sonoran Preserve

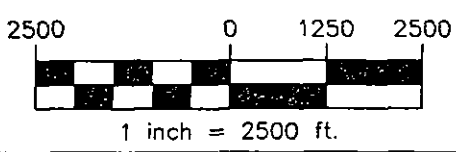

**CROWN**  
COMMUNITY DEVELOPMENT  
*A Honey Creek Company*

**SERENO CANYON**  
Plate I  
"Vicinity Map"

**WOOD/PATEL ASSOCIATES**  
Civil Engineers  
Hydrologists  
Land Surveyors  
(802) 335-8500

**PLATE 1A**

**Phasing Map**

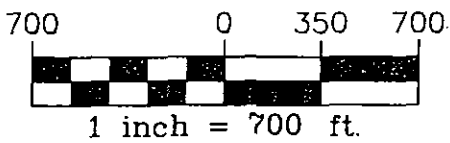
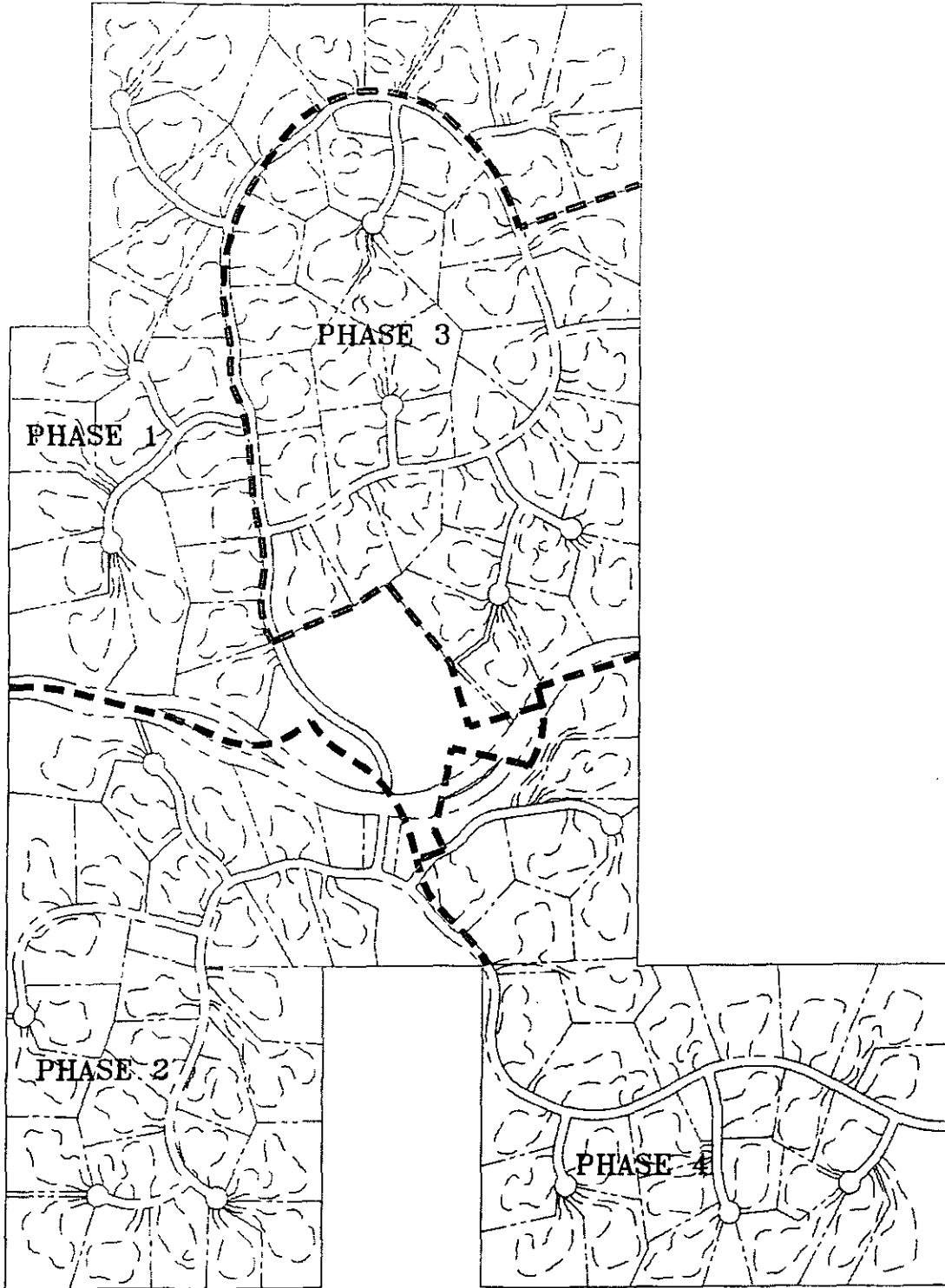

**CROWN**  
 COMMUNITY DEVELOPMENT  
*A Henry Crown Company*

**SERENO CANYON**  
 Plate 1A  
 "Phasing Map"

**WOOD/PATEL**  
**ASSOCIATES**  
 Civil Engineers  
 Hydrologists  
 Land Surveyors  
 (802) 335-8500



**PLATE 2**

**Option 1 Master Wastewater System**

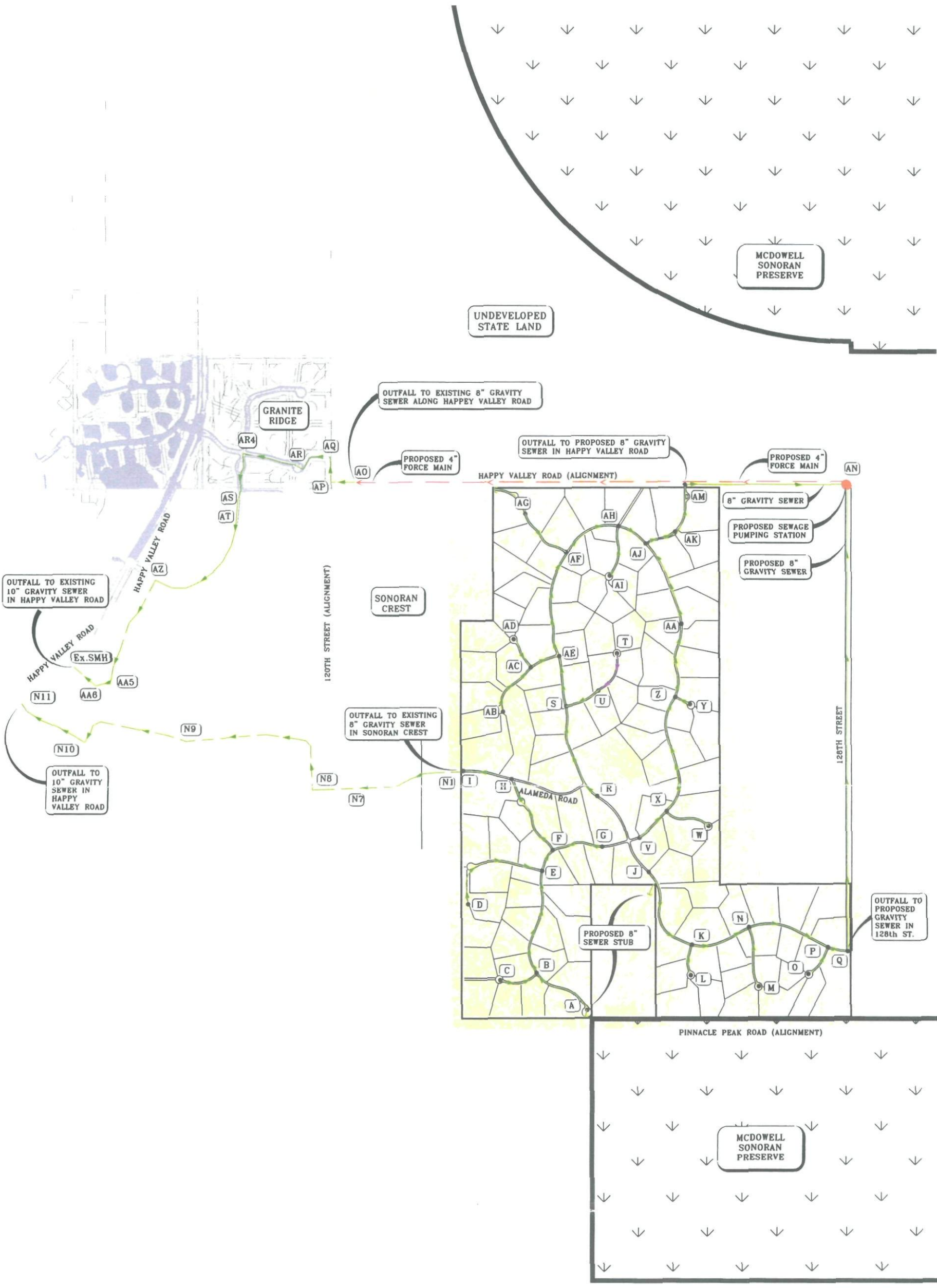

**LEGEND**

- DIRECTION OF FLOW
- 8-INCH SEWER LINE
- FORCE MAIN
- GRAVITY SEWER
- EXISTING SEWER
- 2-INCH INJECTOR LINE

- PROJECT BOUNDARY
- SEWER NODE
- LIFT STATION
- EXISTING 1 FOOT CONTOURS
- EXISTING 5 FOOT CONTOURS
- McDowell Sonoran Preserve

**NOTE**

LOTING AND ROADWAY LAYOUTS ARE CONCEPTUAL AND SUBJECT TO CHANGE. THE SEWER SYSTEM LAYOUT IS A CONCEPTUAL DESIGN ILLUSTRATING THE PIPE SIZES NECESSARY TO SERVE THE DEVELOPMENT AND IS NOT SPECIFIC TO ITS LOCATION.

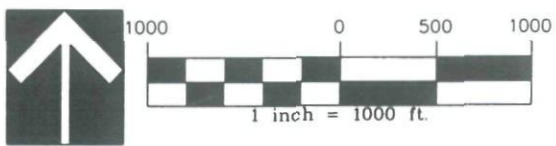

**SERENO CANYON**

Plate 2

"Option 1 - Conceptual Master Wastewater System"

**WOOD/PATEL ASSOCIATES**  
Civil Engineers  
Hydrologists  
Land Surveyors  
(602) 335-8500

**PLATE 3**

**Option 2 Master Wastewater System**



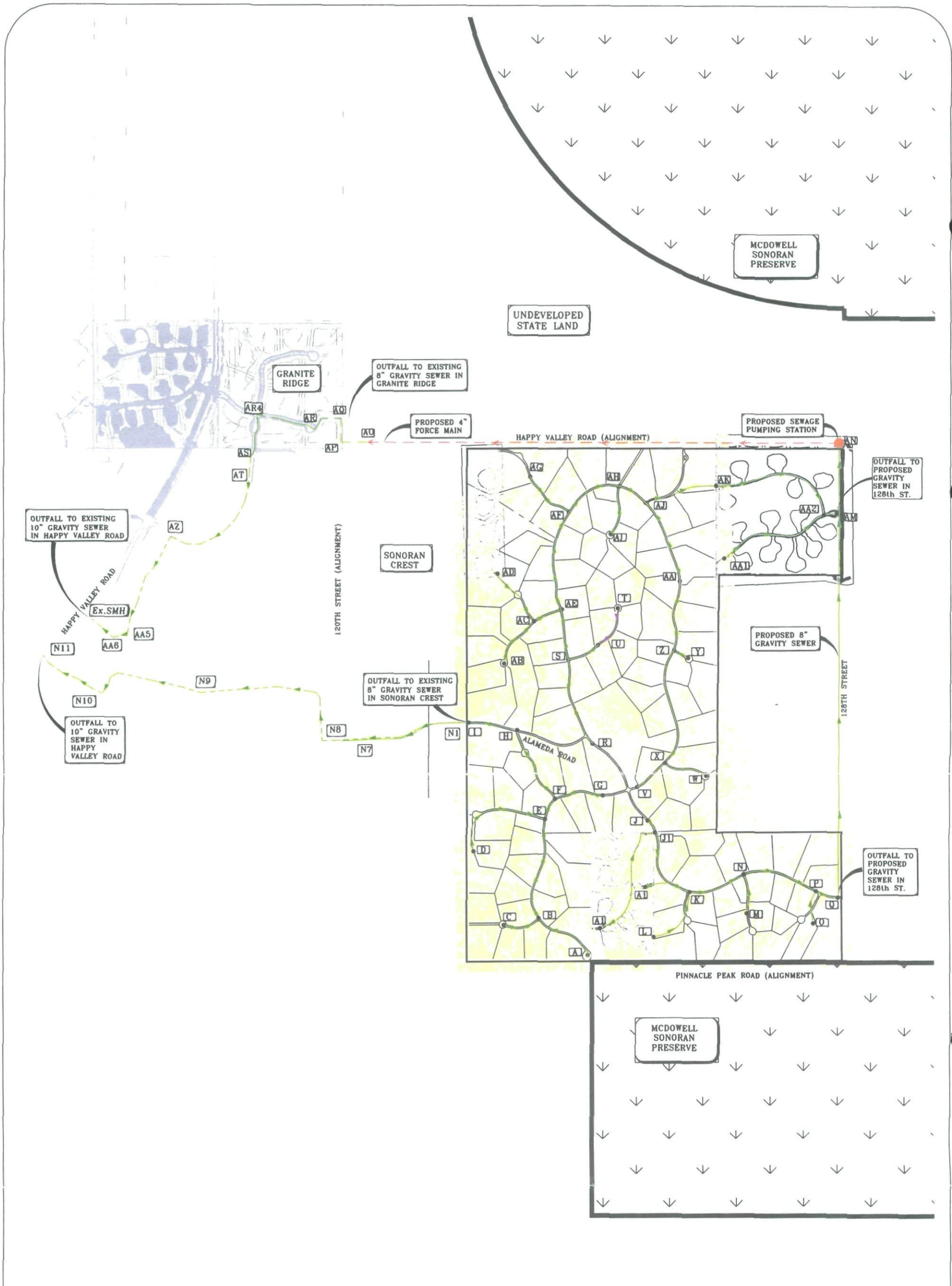

**LEGEND**

- DIRECTION OF FLOW
- 8-INCH SEWER LINE
- FORCE MAIN
- GRAVITY SEWER
- EXISTING SEWER
- PROJECT BOUNDARY
- SEWER NODE
- LIFT STATION
- EXISTING 1 FOOT CONTOURS
- EXISTING 5 FOOT CONTOURS
- McDowell Sonoran Preserve

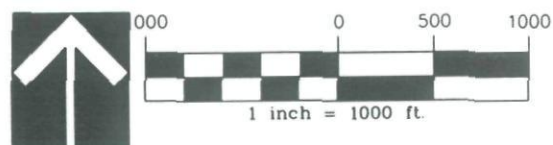

**NOTE**  
 LOTTING AND ROADWAY LAYOUTS ARE CONCEPTUAL AND SUBJECT TO CHANGE. THE SEWER SYSTEM LAYOUT IS A CONCEPTUAL DESIGN ILLUSTRATING THE PIPES SIZE NECESSARY TO SERVE THE DEVELOPMENT AND IS NOT SPECIFIC TO ITS LOCATION.



**SERENO CANYON**

Plate 3

"Option 2 - Conceptual Master Wastewater System"

**WOOD/PATEL ASSOCIATES**  
 Civil Engineers  
 Hydrologists  
 Land Surveyors  
 (602) 335-8500

**PLATE 4**

**Conceptual Master Wastewater System –  
Ultimate Condition**



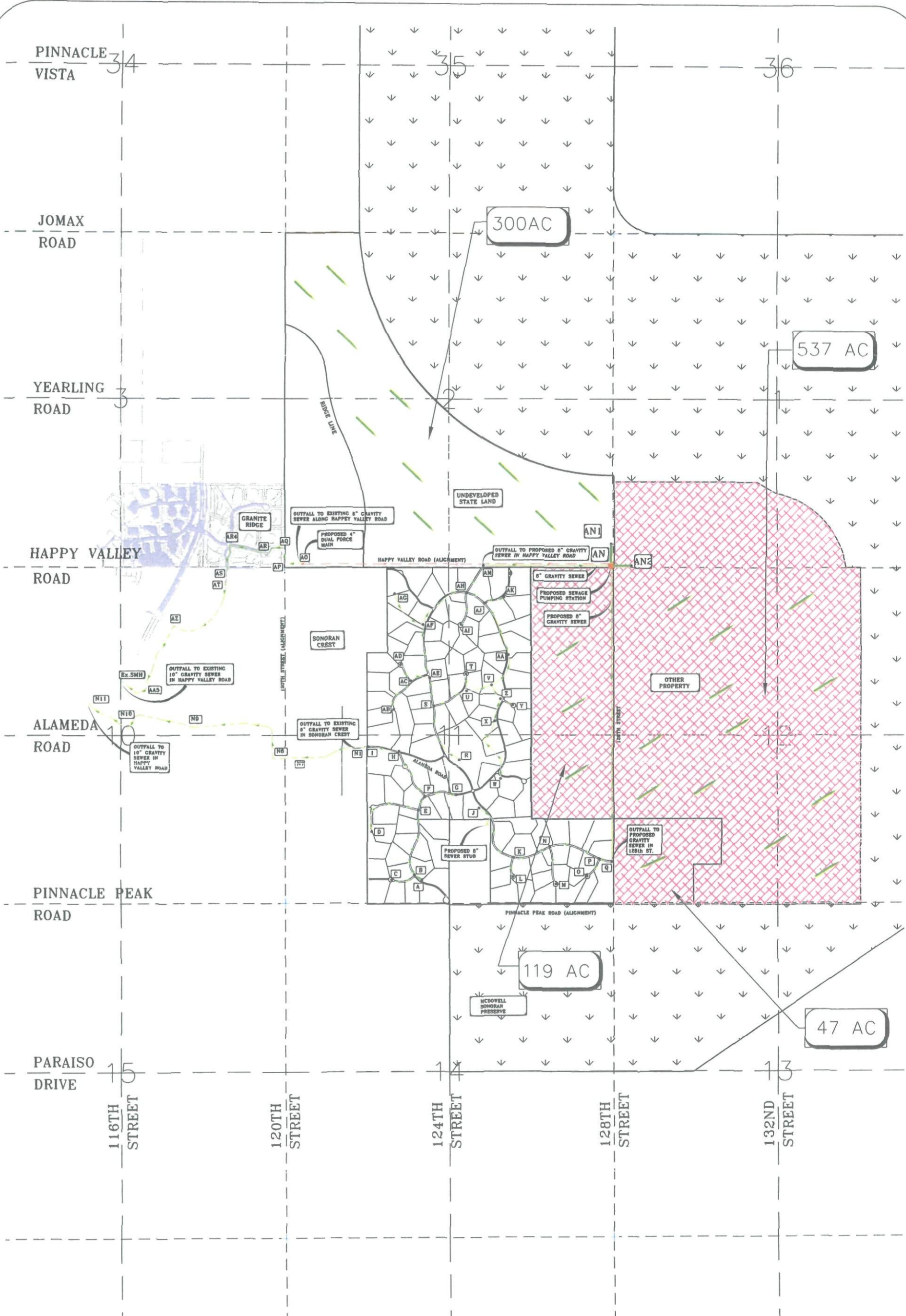

**LEGEND**

- |  |                   |  |                             |
|--|-------------------|--|-----------------------------|
|  | DIRECTION OF FLOW |  | PROJECT BOUNDARY            |
|  | 8-INCH SEWER LINE |  | LIFT STATION                |
|  | FORCE MAIN        |  | Contributing State Land     |
|  | GRAVITY SEWER     |  | Contributing Other Property |
|  | EXISTING SEWER    |  | McDowell Sonoran Preserve   |

**NOTE**  
 LOTTING AND ROADWAY LAYOUTS ARE CONCEPTUAL AND SUBJECT TO CHANGE. THE SEWER SYSTEM LAYOUT IS A CONCEPTUAL DESIGN ILLUSTRATING THE PIPE SIZES NECESSARY TO SERVE THE DEVELOPMENT AND IS NOT SPECIFIC TO ITS LOCATION.

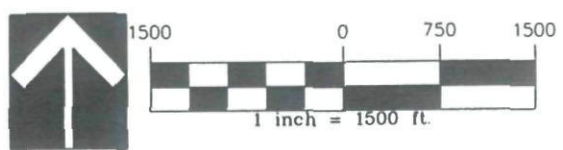

**SERENO CANYON**

Plate 4

"Conceptual Master Wastewater System - Ultimate Condition"

**WOOD/PATEL ASSOCIATES**  
 Civil Engineers  
 Hydrologists  
 Land Surveyors  
 (602) 335-8500



# WOOD/PATEL

LAND DEVELOPMENT • WATER RESOURCES • WATER/WASTEWATER • TRANSPORTATION/TRAFFIC • SURVEYING • CONSTRUCTION MANAGEMENT

Darrel E. Wood, P.E., R.L.S.  
Ashok C. Patel, P.E., R.L.S., CFM  
Gordon W. R. Wark, P.E.  
James S. Campbell, P.E.  
Thomas R. Gettings, R.L.S.  
Timothy A. Huval, P.E.  
Michael T. Young, P.E.  
Peter Hemingway, P.E.  
Jeffrey R. Minch, P.E.  
Robert D. Gofonia, P.E., R.L.S.  
Patrick W. Marum, P.E.

April 11, 2007

Mr. Don Hadder, Sr.  
Planning Director  
City of Scottsdale  
7447 East Indian School Road  
Suite 300  
Scottsdale, AZ 85251

Phone: (480) 312-2352  
Fax: (480) 312-2672  
Email: [dhadder@scottsdaleaz.gov](mailto:dhadder@scottsdaleaz.gov)

Re: **Sereno Canyon – Community Center**  
**Sanitary Sewer Planning Concept Verification**  
WP# 072965

Dear Mr. Hadder:

The purpose of this letter is to provide sanitary sewer planning concept verification in conjunction with the Sereno Canyon Community Center Development Review Board application. The Sereno Canyon Community Center is located within Tract E of the Sereno Canyon Phase 1 Subdivision. The wastewater flows generated by this tract are addressed in Section 2.0 of the approved *Conceptual Master Wastewater System Report for Sereno Canyon Section*. The wastewater flows generated by this site were based on 10,000 s.f. of Community Center (5,000 s.f. building and 5,000 s.f. lawn). This concept is still valid with the current plan for the Community Center as it is currently planned with a 1,700 s.f. building and low-water use landscape area. A copy of the approved *Conceptual Master Wastewater System Report for Sereno Canyon* has been included with this application package.

I am available to answer any questions you may have regarding this matter.

Sincerely,

WOOD, PATEL & ASSOCIATES, INC.

Michael J. Samer, P.E., R.L.S.  
Project Manager

MJS/km

Enclosure(s)

Y:\WP\General Correspondence\072965 Sereno Canyon Community Center Sewer System Concept Verification Letter.doc

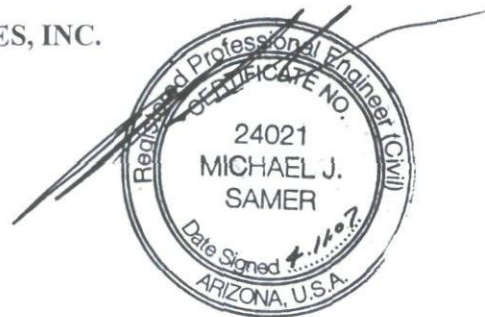

113-DR-2005#2  
5/15/2007