

KEYNOTES

- 1 12x12 SANDSTONE PAVERS ON 1" MORTAR SETTING BED, 4" CONCRETE SLAB & 4" A.B.C. FILL, GROUT ALL JOINTS WITH INTEGRAL COLORED GROUT.
- 2 24x24" SANDSTONE PAVERS PIER KEYNOTE #1.
- 3 INTEGRAL COLORED CONCRETE STAIRS BRONZE TACTILE HOUSINGS.
- 4 6" WIDE CONCRETE EDGE ADJACENT TO PAVERS, ADJ. GRADE TO BE FLUSH WITH FINISH GRADE.
- 5 4" THICK INTEGRAL COLORED CONCRETE WALK SLAB TO EDGE OF PERFORMANCE PLAZA & TURNED DOWN.
- 6 3'-0" W x 1'-6" H CONTINUOUS SEATWALL W/ STONE CAP.
- 7 INTEGRAL COLORED CONCRETE RETAINING WALL WITH SANDBLAST FINISH.
- 8 4" THICK INTEGRAL COLORED CONCRETE WALK SLAB ON 4" A.B.C. SEE SCHEDULE FOR COLOR & FINISH.
- 9 TREE GRATE & FRAME TO BE CAST IN PLACE WITH CONCRETE POUR OF RETAINING WALL.
- 10 STL. RAILINGS, PAINTED, SEE 2/A1.5.
- 11 INTEGRAL COLORED CONCRETE RETAINING WALL WITH TREE GRATE FRAME CAST IN PLACE.
- 12 PLANTER.
- 13 4" THICK INTEGRAL COLORED CONCRETE RAMP SLAB ON 4" A.B.C. & SANDBLASTED FINISH.
- 14 CONTINUOUS CURVED STL. RAILING TO SLOPE DOWN RAMP, SEE 3/A1.5.
- 15 LINE OF FOOTING BEYOND.
- 16 1" PROTECTION BOARD OVER CEMENTATIONS WATERPROOFING TO TOP OF FOOTINGS.
- 17 PLANTER POT SET ON TOP OF CONCRETE CAP.

Ellermann Schick
 architecture planning
 727 E. MARYLAND AVE
 Phoenix, AZ 85014
 phone: 602.266.6202
 fax: 602.265.6212

THIS DRAWING IS AN INSTRUMENT OF SERVICE. IT IS THE PROPERTY OF ELLERMANN & SCHICK, INC. AND MAY NOT BE REPRODUCED WITHOUT WRITTEN PERMISSION.

THE PROMENADE - PHASE 2
 HARDSCAPE AND PERFORMANCE PLAZA
 AT
 S.E.C. OF FRANK LLOYD WRIGHT & SCOTTSDALE ROAD
 FOR
THE PEDERSON GROUP

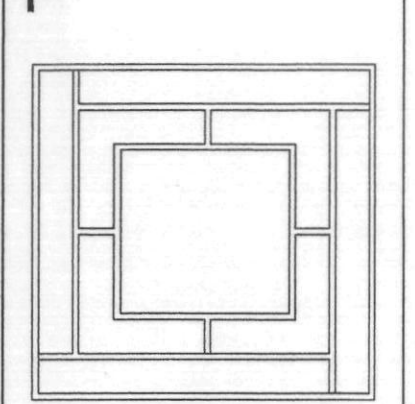

Pederson GROUP, INC.
 ARCHITECT
 1100 N. CENTRAL AVENUE
 SUITE 100
 PHOENIX, AZ 85004
 TEL: 602.266.6202
 FAX: 602.265.6212

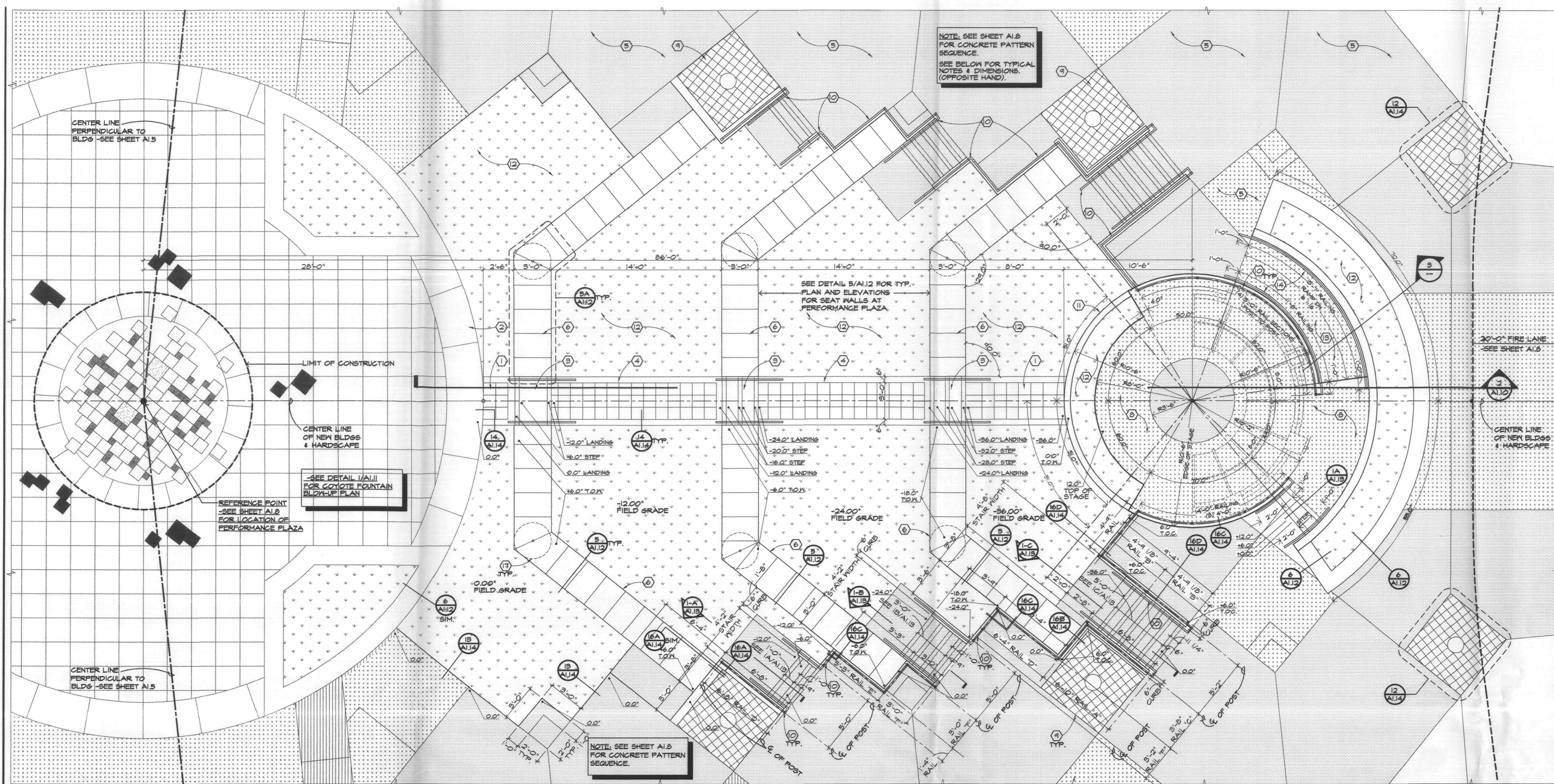

1 PLAN @ PERFORMANCE PLAZA
 SCALE: 1/4"=1'-0"
 PLAZA PLAN.DWG

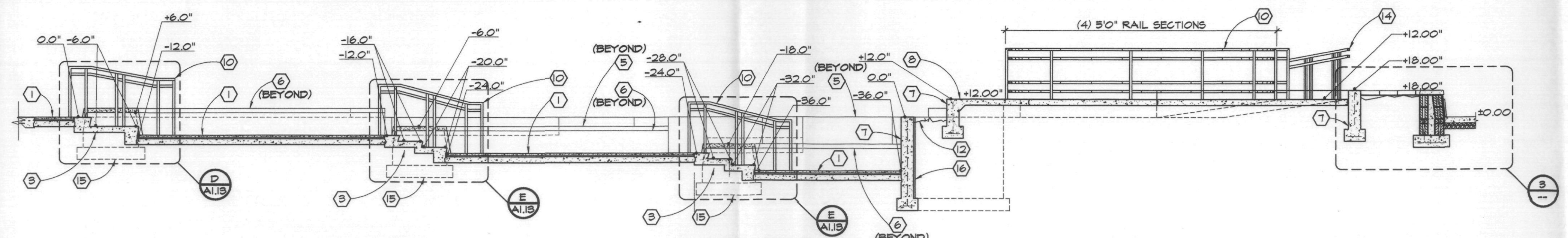

2 SECTION @ PERFORMANCE PLAZA
 SCALE: 1/4"=1'-0"
 PLAZA PLAN.DWG

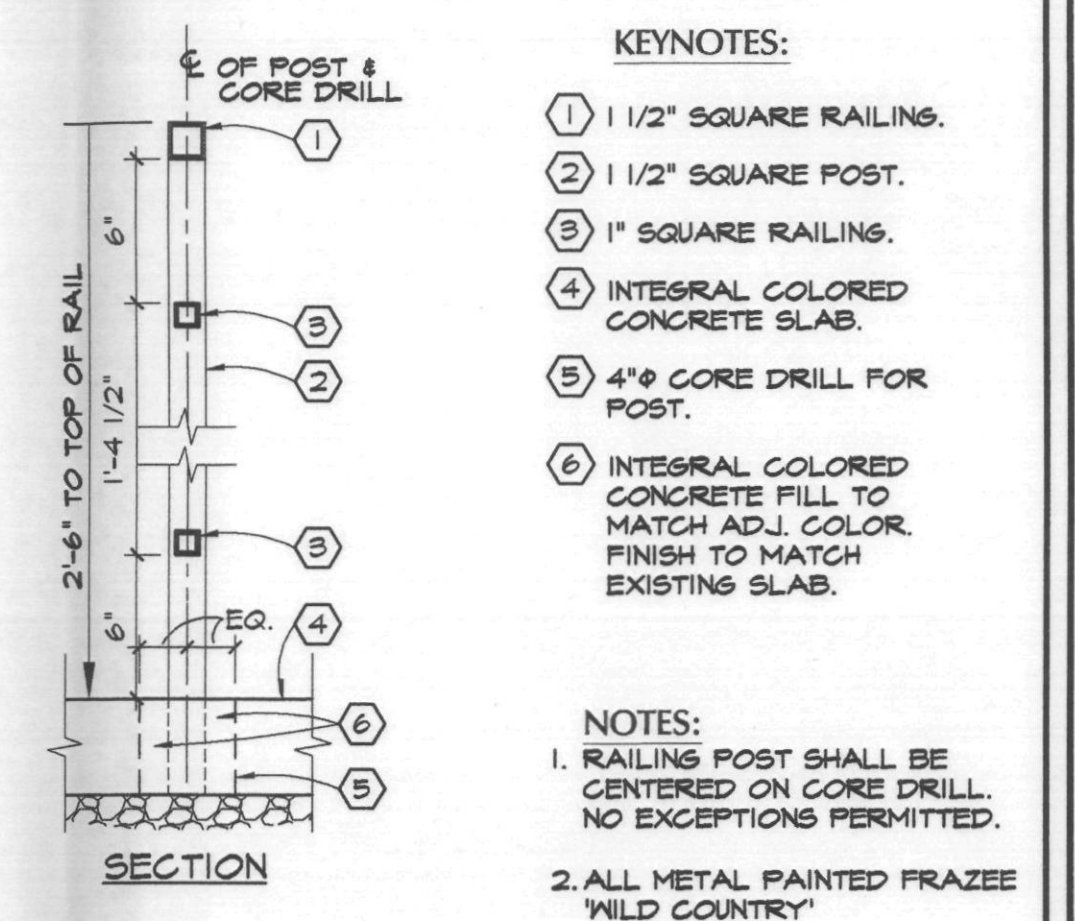

5 RAIL @ CONCRETE
 SCALE: 1 1/2"=1'-0"
 A11005.DWG

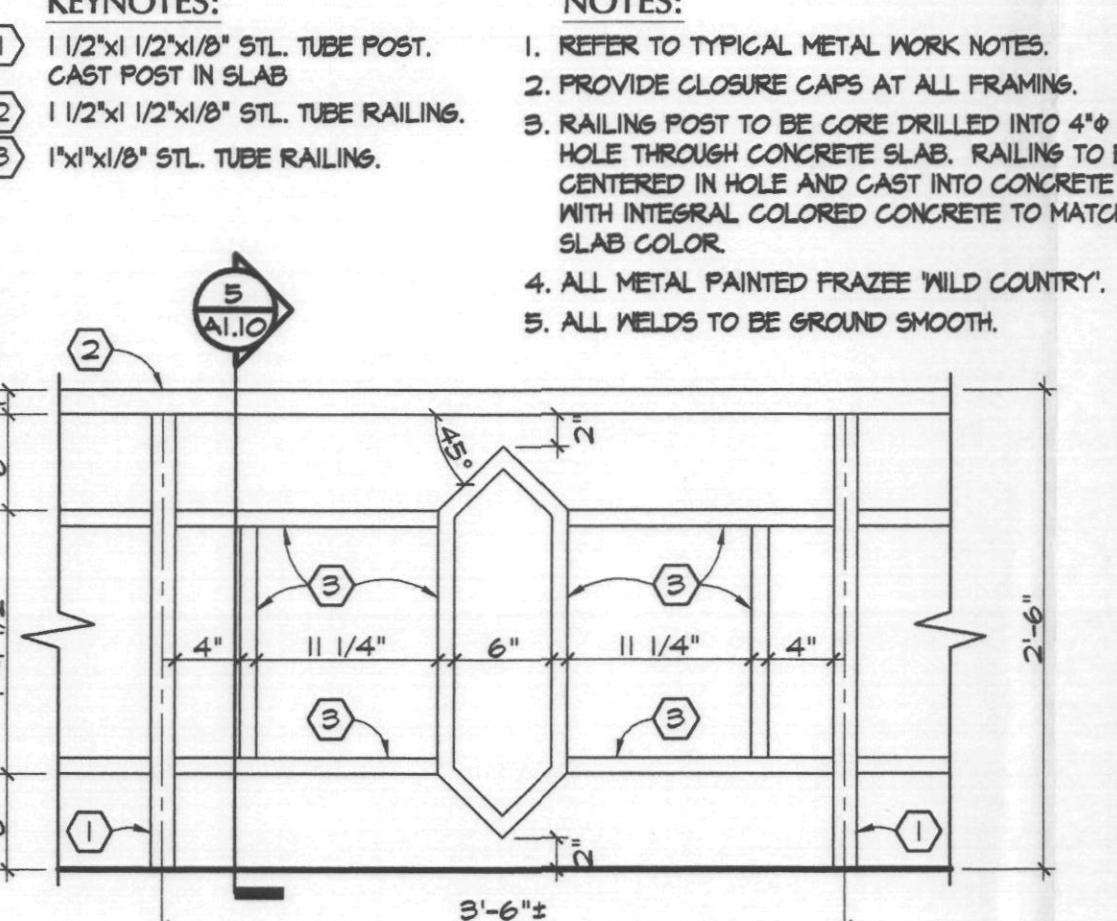

4 RAILING ELEVATION
 SCALE: 1"=1'-0"
 A11004.DWG

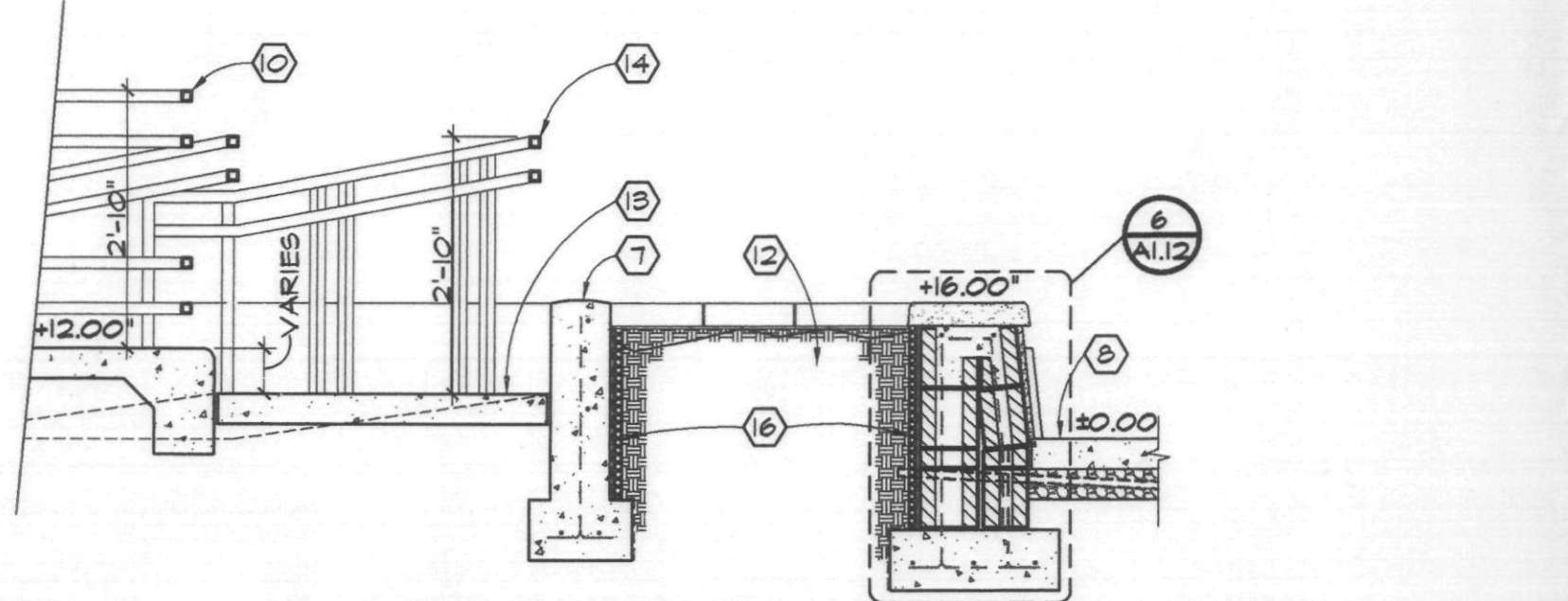

3 RAMP @ PERFORMANCE PLAZA
 SCALE: 1/2"=1'-0"
 RAMP.DWG

SHEET NOTES

- A. ALL ELEVATIONS ARE REFERENCED FROM TO OF HARDSCAPE ADJACENT TO PERFORMANCE PLAZA BEING 0.00'. REFER TO CIVIL PLANS FOR ACTUAL GRADES.
- B. ALL INTEGRAL COLORED CONCRETE AT EDGE OF PERFORMANCE PLAZA SHALL CONTINUE TO RUN DOWN INSIDE FACE OR PERFORMANCE PLAZA. FINISH TO BE LIGHT SANDBLAST.
- C. ALL RETAINING WALLS SHALL RECEIVE CEMENTATIONS WATERPROOFING TO BOTTOM OF FOOTING & 1" PROTECTION BOARD TO TOP OF FOOTING ON RETAINING SIDE OF WALL.
- D. STAIR & RAMP LANDINGS SHALL BE SLOPED TO DRAIN AT 1:50 AWAY FROM STAIRS & RAMP.
- E. ALL RAILING DIMENSIONS SHALL BE FIELD VERIFIED PRIOR TO FABRICATION, S.C. TO VERIFY AT TIME OF INSTALLATION THAT RAILINGS/GUARDRAILS SHALL CONFORM TO ALL APPLICABLE CODES AND SAFETY STANDARDS PRIOR TO FINAL INSTALLATION.

APPROVED
 ORIGINAL PLANS
 DATE: 05/24/04
 DATE: 07/11/04

HARDSCAPE LEGEND

- 1 4" INTEGRAL COLORED 'MAHA TAN' CONCRETE ON 4" A.B.C. FINISH TO BE LIGHT SWIRL WITH 3" SMOOTH STEEL TROVEL BORDER AT JOINT. SEE KEYNOTES FOR CONCRETE IN TRAFFIC LANES.
- 2 4" INTEGRAL COLORED 'FLASSTONE BROWN' CONCRETE ON 4" A.B.C. FINISH TO BE LIGHT SWIRL WITH 3" SMOOTH STEEL TROVEL BORDER AT JOINT. SEE KEYNOTES FOR CONCRETE IN TRAFFIC LANES.
- 3 4" NATURAL GREY CONCRETE ON 4" A.B.C. FINISH TO BE MEDIUM BROOK AND RUN IN DIRECTION PERPENDICULAR TO BUILDING. 3" STL. TROVEL BORDER AROUND EACH PANEL AT JOINT.
- 4 CUT SANDSTONE PAVERS, 1 SINGLE STONE OR 2'-0" x 2'-0" AS SHOWN BY GRID. STONES SET ON 1" MORTAR SETTING BED OVER 4" CONC. SUB SLAB ON 4" A.B.C. JOINTS TO BE INTEGRAL COLOR GROUT TO MATCH.
- 5 RANDOM SANDSTONE PAVERS.
- 6 LANDSCAPE PLANTER.

| CITY COMMENTS | COORDINATION | OFFICE 1B REVISIONS | HARDSCAPE REVISIONS |
|---------------|--------------|---------------------|---------------------|
| | | | |
| | | | |
| | | | |

| DESIGN DEVELOPMENT |
|-------------------------|
| CONSTRUCTION DOCUMENTS |
| BID/PRICING PACKAGE |
| BUILDING DEPT. APPROVAL |

DATE ISSUED: 03.05.03
 DRAWN BY: DCR/CG
 CHECKED BY: SMP/RHS
 PROJECT NO.: 22000
 CADD FILE:
 SCALE: AS NOTED
 DRAWING NO.:

A1.10
 PERFORMANCE PLAZA

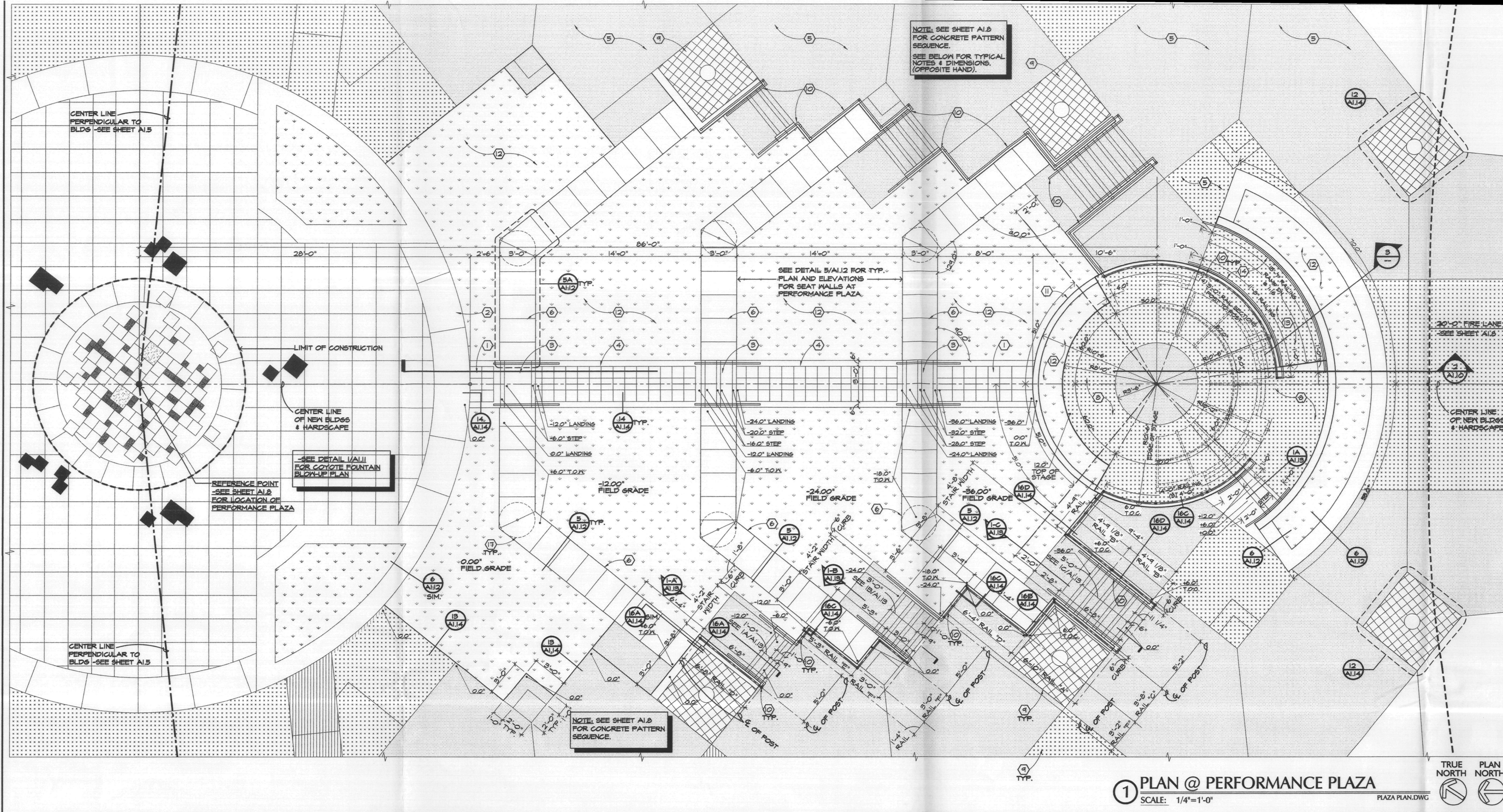

1 PLAN @ PERFORMANCE PLAZA
SCALE: 1/4"=1'-0"
PLAZA PLAN.DWG

- KEYNOTES**
- 12x12 SANDSTONE PAVERS ON 1" MORTAR SETTING BED, 4" CONCRETE SLAB & 4" A.B.C. FILL, GROUT ALL JOINTS WITH INTEGRAL COLORED GROUT.
 - 24x24" SANDSTONE PAVERS PIER KEYNOTE #1.
 - INTEGRAL COLORED CONCRETE STAIRS BRONZE TACTILE HOUSINGS.
 - 6" WIDE CONCRETE EDGE ADJACENT TO PAVERS, ADJ. GRADE TO BE FLUSH WITH FINISH GRADE.
 - 4" THICK INTEGRAL COLORED CONCRETE MALK SLAB TO EDGE OF PERFORMANCE PLAZA & TURNED DOWN.
 - 3'-0" H x 1'-6" W CONTINUOUS SEATWALL W/ STONE CAP
 - INTEGRAL COLORED CONCRETE RETAINING WALL WITH SANDBLAST FINISH.
 - 4" THICK INTEGRAL COLORED CONCRETE MALK SLAB ON 4" A.B.C., SEE SCHEDULE FOR COLOR & FINISH
 - TREE GRATE & FRAME, FRAME TO BE CAST IN PLACE WITH CONCRETE FOUR OF RETAINING WALL.
 - STL. RAILINGS, PAINTED, SEE 2/A1.15
 - INTEGRAL COLORED CONCRETE RETAINING WALL WITH TREE GRATE FRAME CAST IN PLACE.
 - PLANTER.
 - 4" THICK INTEGRAL COLORED CONCRETE RAMP SLAB ON 4" A.B.C. & SANDBLAST FINISH.
 - CONTINUOUS CURVED STL. RAILINGS TO SLOPE DOWN RAMP, SEE 3/A1.15
 - LINE OF FOOTING BEYOND.
 - 1" PROTECTION BOARD OVER GENERATIONS WATERPROOFING TO TOP OF FOOTING.
 - PLANTER POT SET ON TOP OF CONCRETE CAP.

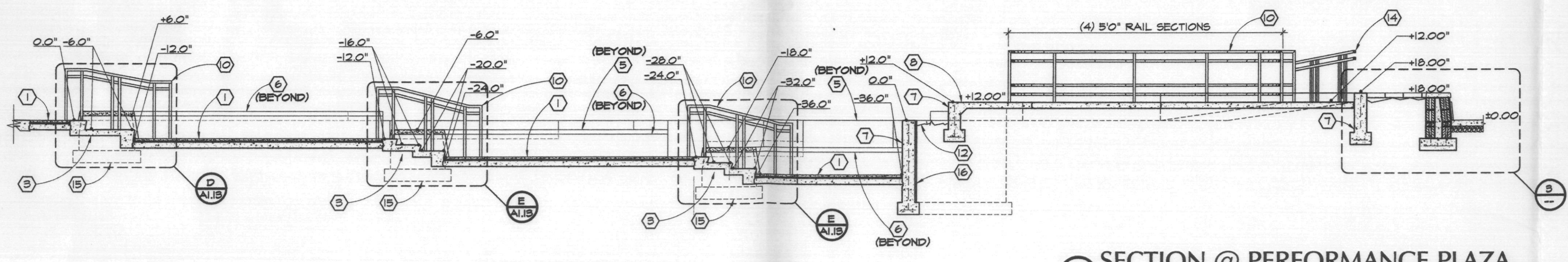

2 SECTION @ PERFORMANCE PLAZA
SCALE: 1/4"=1'-0"
PLAZA PLAN.DWG

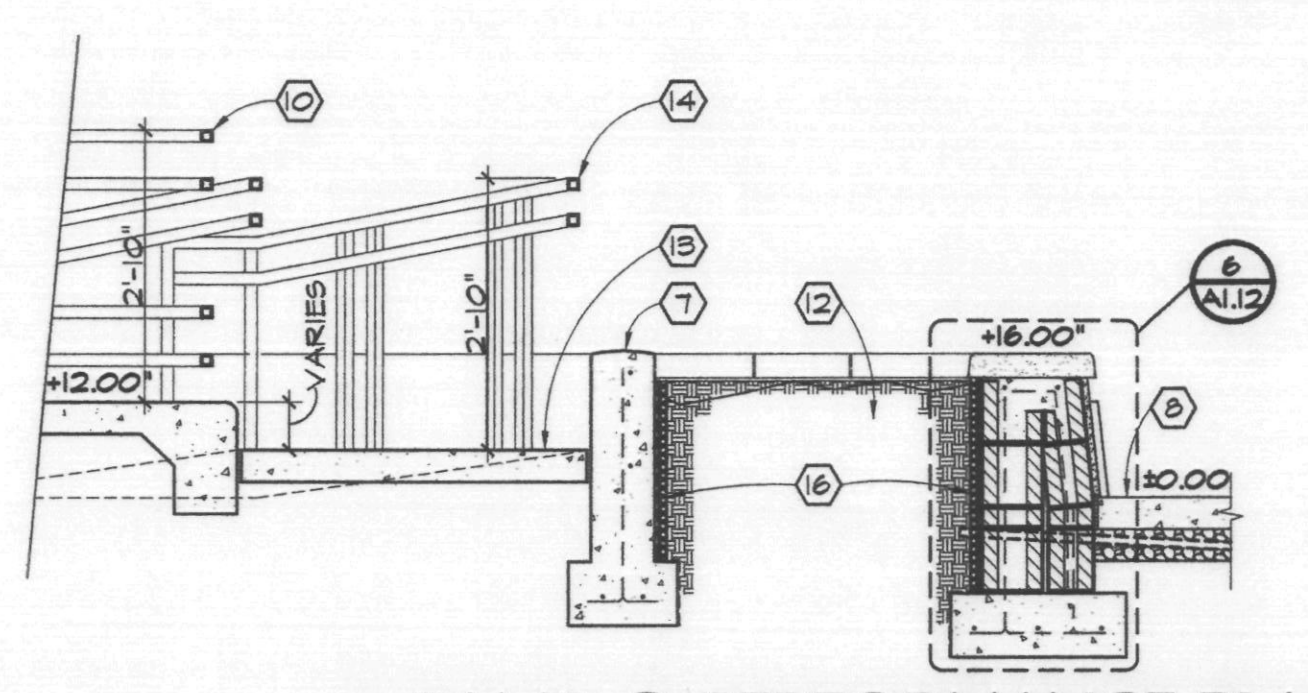

3 RAMP @ PERFORMANCE PLAZA
SCALE: 1/2"=1'-0"
RAMP.DWG

SHEET NOTES

- ALL ELEVATIONS ARE REFERENCED FROM TO OF HARDSCAPE ADJACENT TO PERFORMANCE PLAZA BEING 0.00'. REFER TO CIVIL PLANS FOR ACTUAL GRADES.
- ALL INTEGRAL COLORED CONCRETE AT EDGE OF PERFORMANCE PLAZA SHALL CONTINUE TO RUN DOWN INSIDE FACE OR PERFORMANCE PLAZA, FINISH TO BE LIGHT SANDBLAST.
- ALL RETAINING WALLS SHALL RECEIVE GENERATIONS WATERPROOFING TO BOTTOM OF FOOTING & 1" PROTECTION BOARD TO TOP OF FOOTING ON RETAINING SIDE OF WALL.
- STAIR & RAMP LANDINGS SHALL BE SLOPED TO DRAIN AT 1:50 AWAY FROM STAIRS & RAMP.
- ALL RAILING DIMENSIONS SHALL BE FIELD VERIFIED PRIOR TO FABRICATION, G.C. TO VERIFY AT TIME OF INSTALLATION THAT RAILINGS/GUARDRAILS SHALL CONFORM TO ALL APPLICABLE CODES AND SAFETY STANDARDS PRIOR TO FINAL INSTALLATION.

Richard H. Schick
APPROVED
FINAL PLANS PLANNING
6/12/03

HARDSCAPE LEGEND

- 4" INTEGRAL COLORED "OMAHA TAN" CONCRETE ON 4" A.B.C., FINISH TO BE LIGHT SWIRL WITH 3" SMOOTH STEEL TROWEL BORDER AT JOINT. SEE KEYNOTES FOR CONCRETE IN TRAFFIC LANES.
- 4" INTEGRAL COLORED "LAGSTONE BROWN" CONCRETE ON 4" A.B.C., FINISH TO BE LIGHT SWIRL WITH 3" SMOOTH STEEL TROWEL BORDER AT JOINT. SEE KEYNOTES FOR CONCRETE IN TRAFFIC LANES.
- 4" NATURAL GREY CONCRETE ON 4" A.B.C., FINISH TO BE MEDIUM BROOM AND RUN IN DIRECTION PERPENDICULAR TO BUILDING, 3" STL. TROWEL BORDER AROUND EACH PANEL AT JOINT.
- CUT SANDSTONE PAVERS, 1 SINGLE STONE OR 2'-0" x 2'-0" AS SHOWN BE GRID. STONES SET ON 1" MORTAR SETTING BED OVER 4" CONC. SUB SLAB ON 4" A.B.C., JOINTS TO BE INTEGRAL COLOR GROUT TO MATCH.
- RANDOM SANDSTONE PAVERS.
- LANDSCAPE PLANTER

727 E. MARYLAND AVE
Phoenix, AZ 85014
phone: 602.266.6202
facsimile: 602.265.6212

THIS DRAWING IS AN INSTRUMENT OF SERVICE. IT IS THE PROPERTY OF ELLERMANN & SCHICK, INC. AND MAY NOT BE REPRODUCED WITHOUT WRITTEN PERMISSION.

THE PROMENADE - PHASE 2
HARDSCAPE AND PERFORMANCE PLAZA
S.E.C. OF FRANK LYONDS WRIGHT & SCOTTSDALE ROAD
SCOTTSDALE, ARIZONA
FOR
THE PEDERSON GROUP

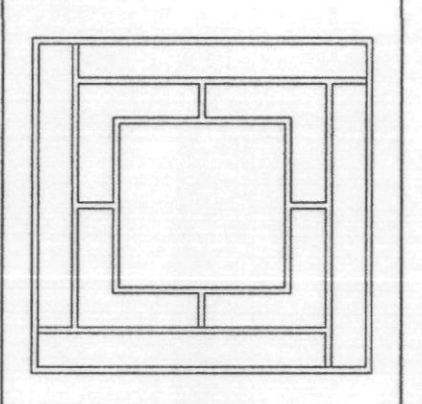

Pederson
GROUP, INC.

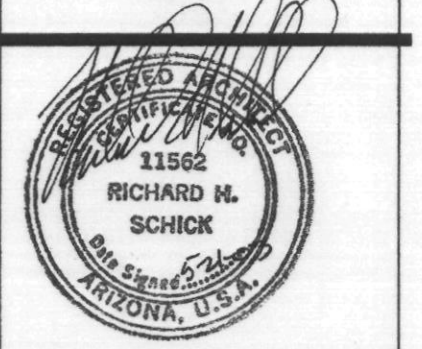

| | |
|---------------|----------|
| CITY COMMENTS | |
| DATE ISSUED | 03.05.03 |
| DRAWN BY | DCR/CG |
| CHECKED BY | SMP/RHS |
| PROJECT NO. | 22000 |
| CADD FILE | |
| SCALE: | AS NOTED |
| DRAWING NO. | |

| | |
|-------------------------|--|
| SCHEMATIC | |
| DESIGN DEVELOPMENT | |
| CONSTRUCTION DOCUMENTS | |
| BID/PRICING PACKAGE | |
| BUILDING DEPT. APPROVAL | |

A1.10
PERFORMANCE PLAZA