

△ Main Entry Gates Elevation 1/2" = 1-0

- KEYNOTES:**
1. 8" CMU SITEWALLS W/ INTEGRALLY COLORED, TROWELED FINISH ELASTOMERIC STUCCO. COLOR TO BE SIMILAR TO DUNN EDWARDS DE 6201 RATTAN BASKET LRV 27 TYPICAL UNLESS NOTED OTHERWISE. ALSO SEE DETAIL.
  2. NATURAL SITE HARVESTED BOULDERS INTEGRATED WITH THE WALL CONSTRUCTION. MUD SET VARIOUS SIZE. GENERAL CONTRACTOR SHALL COORDINATE EXACT PLACEMENT WITH ARCHITECT.
  3. NATURAL SITE HARVESTED BOULDERS
  4. ELECTRIC REMOTE GATE OPERATORS
  5. CUSTOM WROUGHT IRON GATES - FABRICATOR SHALL SUBMIT SHOP DRAWINGS FOR REVIEW & APPROVAL BY ARCHITECT PRIOR TO FABRICATION
  6. EDGE OF ROAD
  7. 6" SQUARE STEEL GATE SUPPORT COLUMNS WITH DECORATIVE STEEL APPLIQUES
  8. NATURAL STONE VENEER SIMILAR TO APACHE STONE'S DC COBBLE. MUD SET MORTAR WASHED WITH COLORED MORTAR TO MATCH BUILDING COLOR.
  9. FINISH GRADE
  10. LOCATION OF KNOX-BOX - ALSO SEE FIRE ORDINANCE REQUIREMENTS SHEET T.

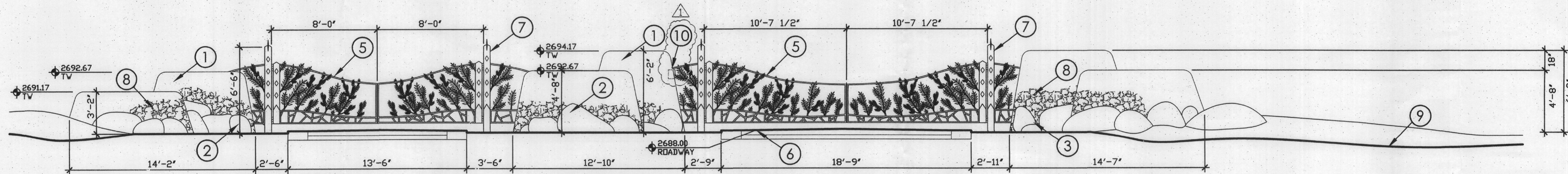

△ (A) Main Entry Gates & Site Walls Elevations 1/4" = 1-0

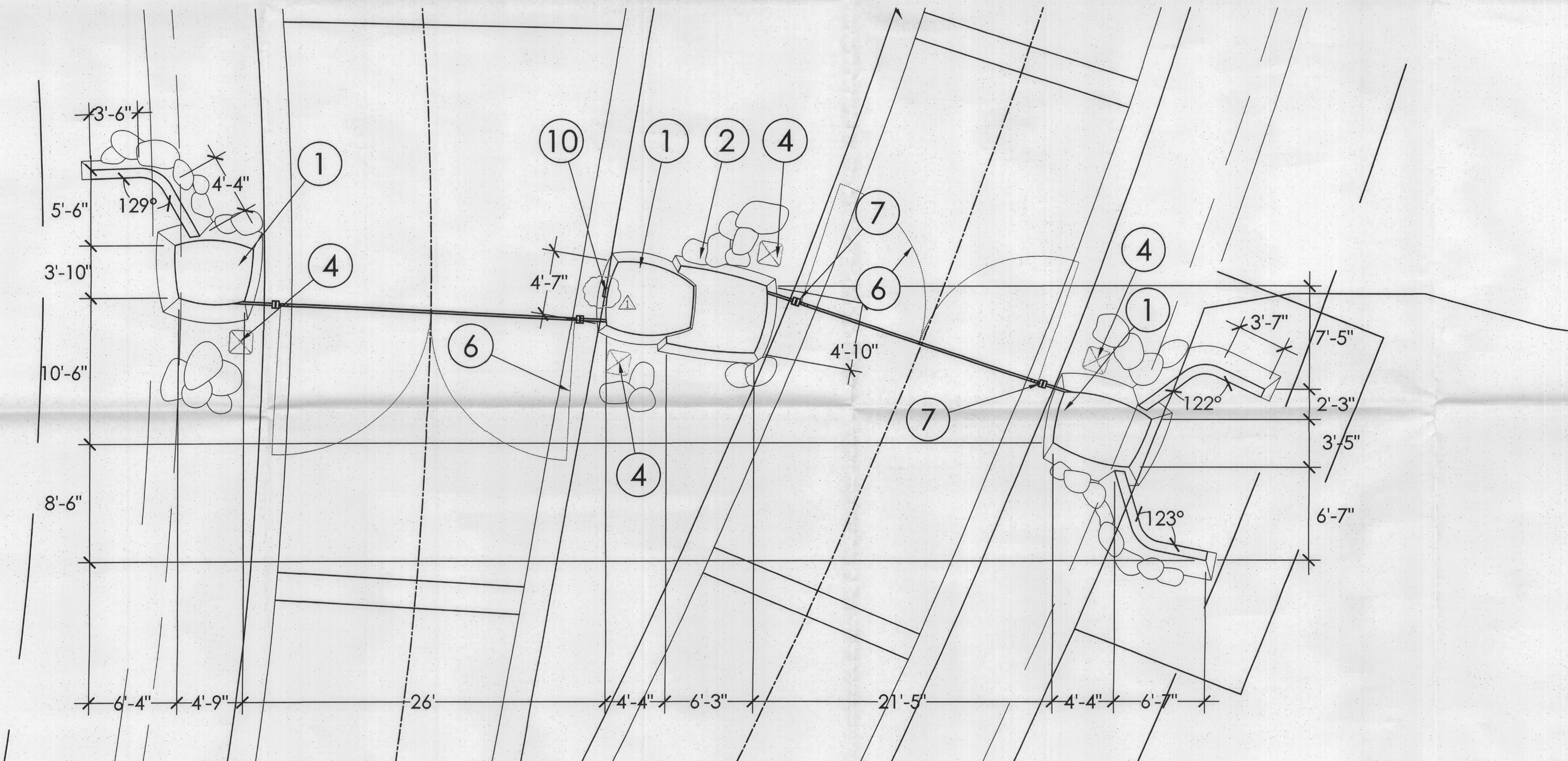

**NOTE:**  
INTEGRATED BOULDER PLACEMENT IN SITEWALLS  
FIELD VERIFY WITH ARCHITECT

1655-07-3  
**APPROVED**  
FINAL PLANS PLANNING  
1-16-08  
113-DE-2005-42 30-SA-2008  
NORTH

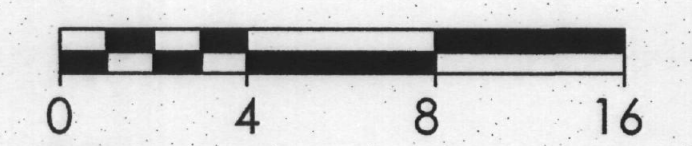

Main Entry Gates Plans 1/4" = 1'-0"

**Craig Wickersham Architects**  
15821 N. 79th Street  
Suite 2  
Scottsdale, AZ 85260  
480 609-6766

**DISCLAIMER:**  
These drawings are prepared by the Architect and are not to be used for any other purpose without the written consent of the Architect.

**REVISIONS:**

NO.	DATE	BY	DESCRIPTION
1	DEC 18 2007	WICKERSHAM	ISSUED FOR PERMITS
2	JAN 2008	WICKERSHAM	ISSUED FOR PERMITS

**Sereno Canyon**  
Crown Community Development

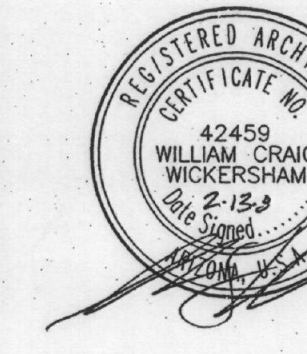

JOB NO. 0702  
DATE DEC 18 07  
SCALE(S) SHOWN  
DRAWN SJR  
CHECKED WCW  
PLAN CHECK NO. 1655-07-0



**DISCLAIMER:**  
 These drawings are prepared by the Architect and are intended to be used for the construction of the project. The Architect does not warrant the accuracy of the information provided herein, and the user of these drawings assumes all liability for the use of these drawings.

**REVISIONS:**

NO.	DATE	BY	DESCRIPTION
1	DEC 18 2007	WICKERSHAM	ISSUED FOR PERMIT
2	JAN 2008	WICKERSHAM	REVISED PER COMMENTS

**KEYNOTES:**

1. 8" CMU SITEWALLS W/ INTEGRALLY COLORED, TROWELED FINISH ELASTOMERIC STUCCO. COLOR TO BE SIMILAR TO DUNN EDWARDS DE 6201 RATTAN BASKET LRV 27 TYPICAL UNLESS NOTED OTHERWISE. ALSO SEE DETAIL
2. NATURAL SITE HARVESTED BOULDERS INTEGRATED WITH THE WALL CONSTRUCTION. MUD SET VARIOUS SIZE. GENERAL CONTRACTOR SHALL COORDINATE EXACT PLACEMENT WITH ARCHITECT.
3. CURB (SEE CIVIL)
4. SIDEWALK (SEE CIVIL)
5. ENTRY SIGNAGE WALLS
6. ENTRY/EXIT GATES
7. ELECTRIC REMOTE GATE OPERATORS
8. NATURAL STONE VENEER SIMILAR TO APACHE STONES DC COBBLE. MUD SET MORTAR WASHED WITH COLORED MORTAR TO MATCH BUILDING COLOR.
9. LOCATION OF KNOX-BOX - ALSO SEE FIRE ORDINANCE REQUIREMENTS SHEET T.

**GENERAL NOTES:**

- A. SEE STRUCTURAL CALCULATIONS FOR STRUCTURAL ENGINEERING ON SITE WALLS, TYP.

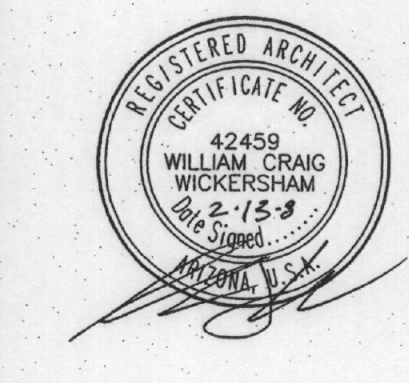
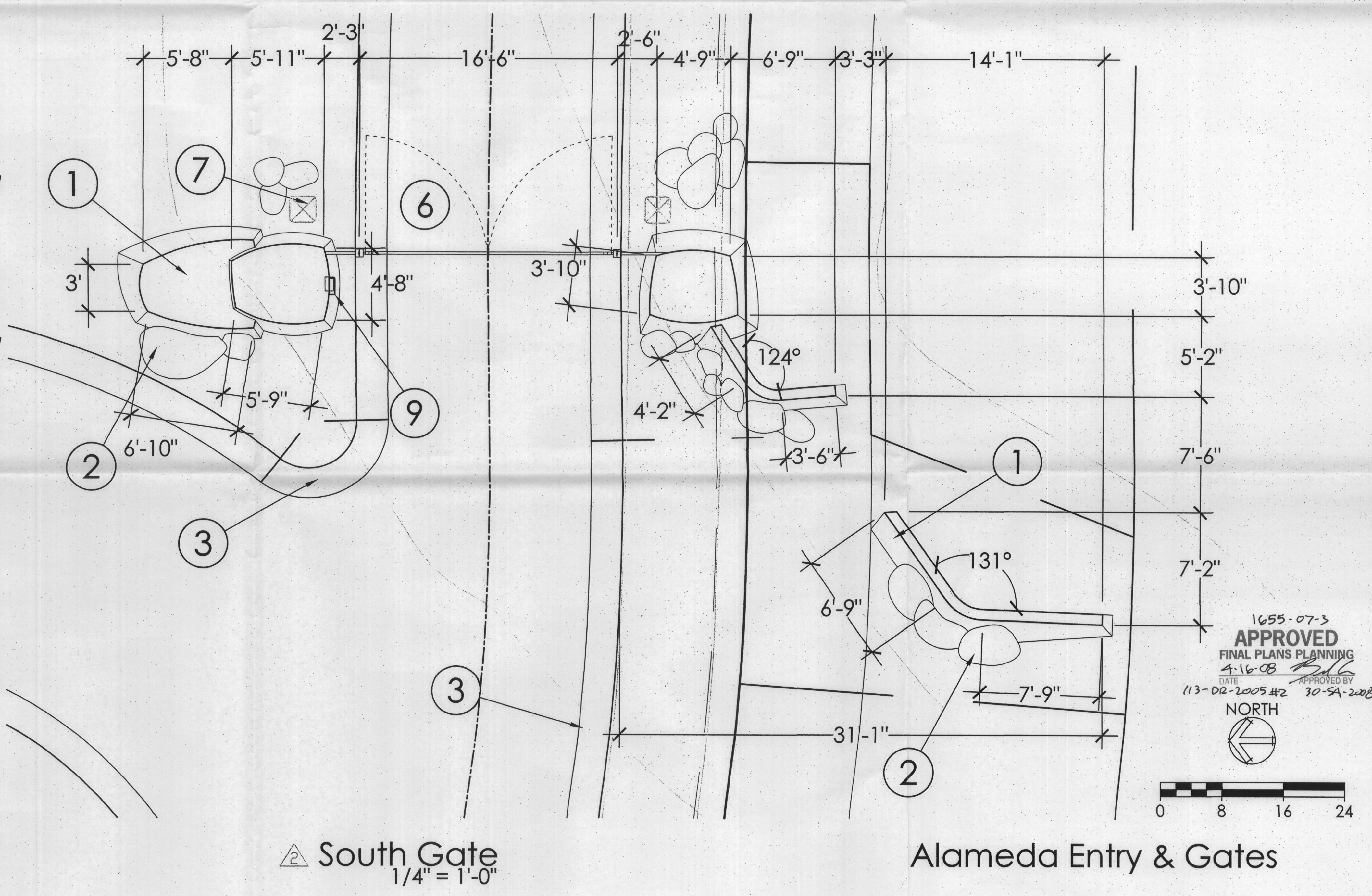
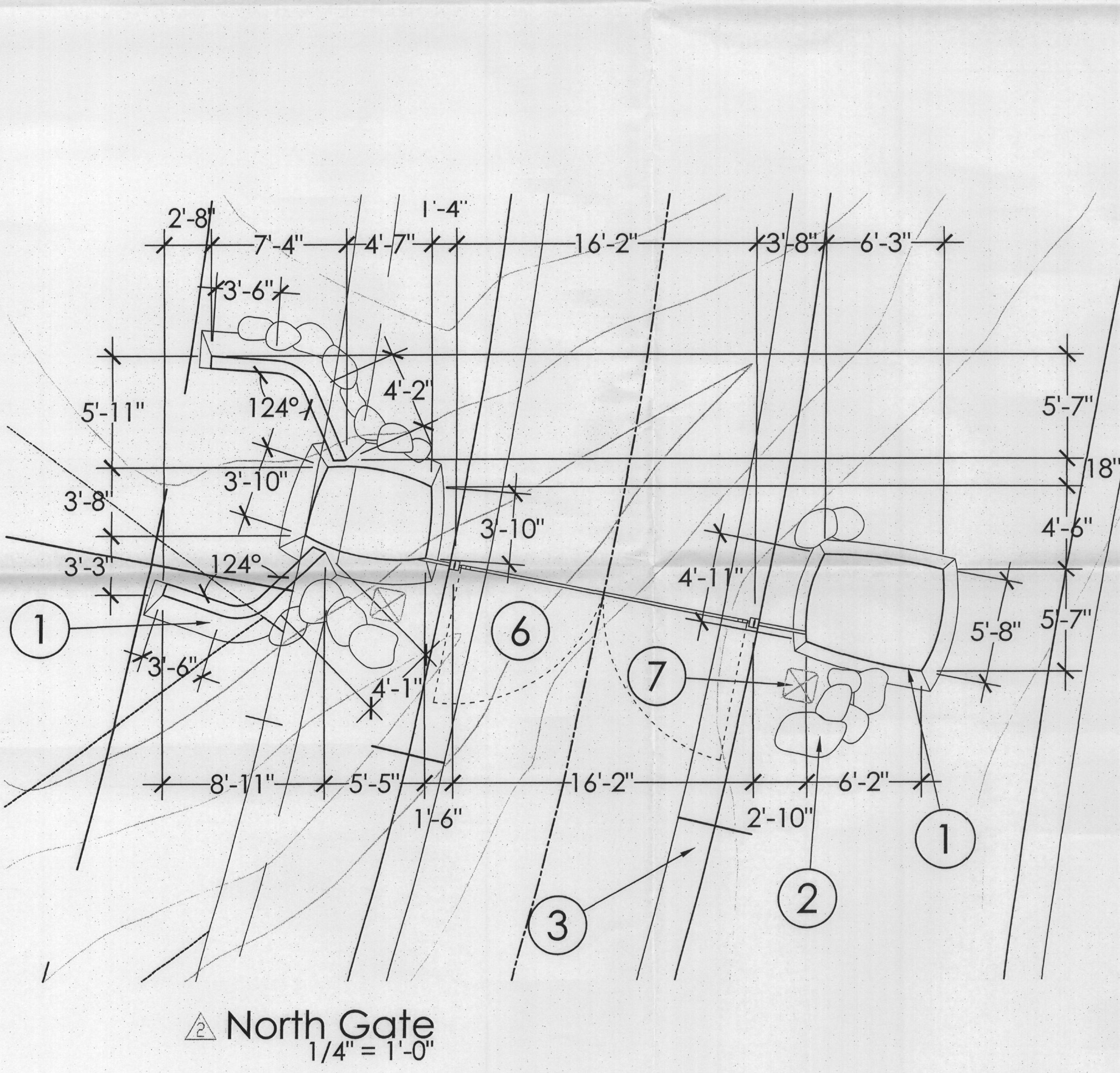
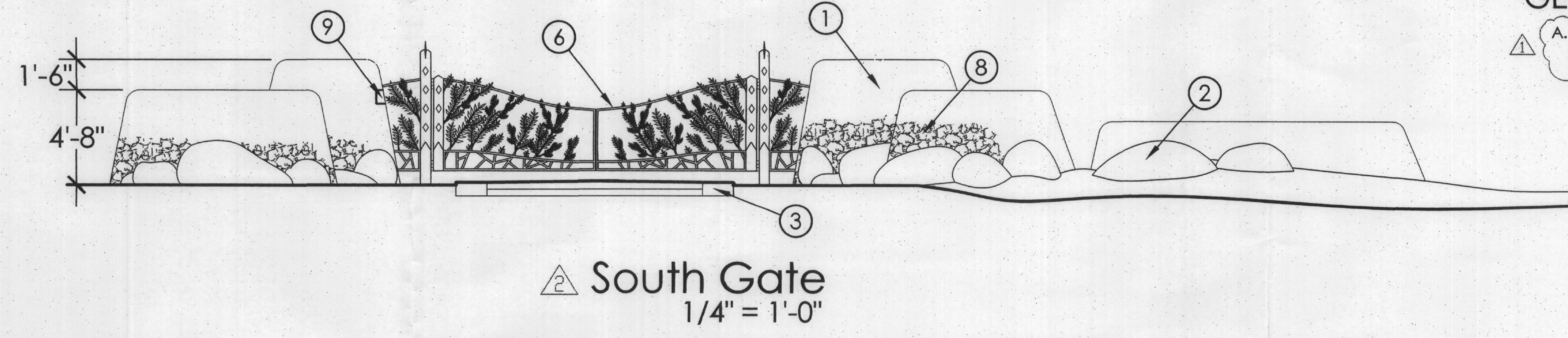
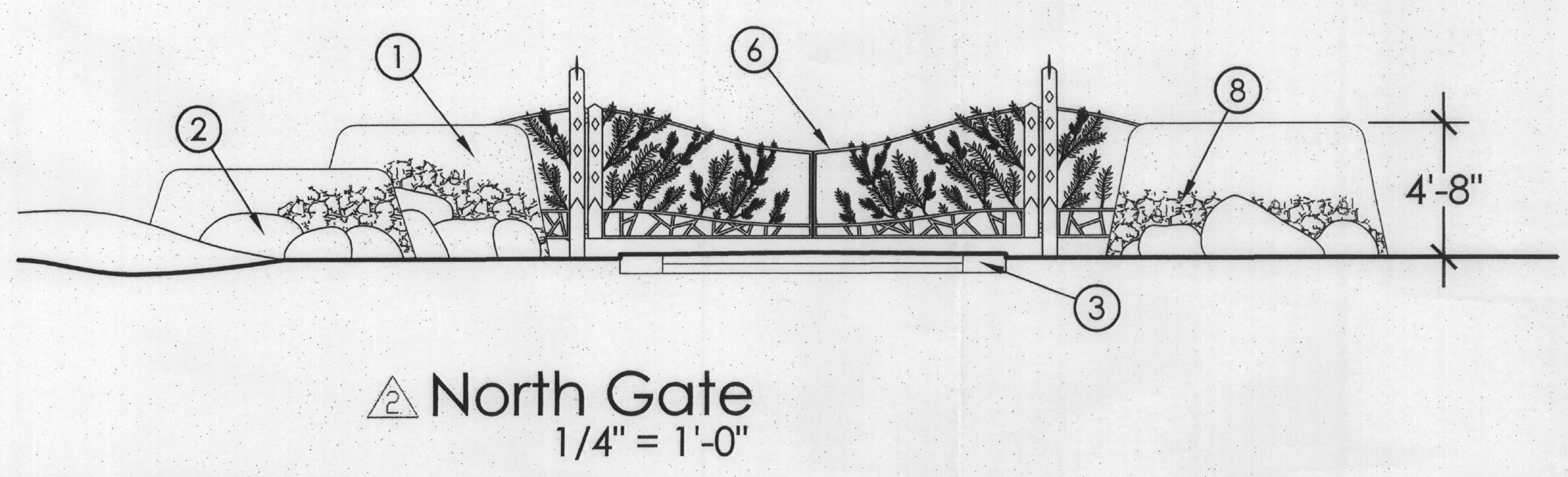
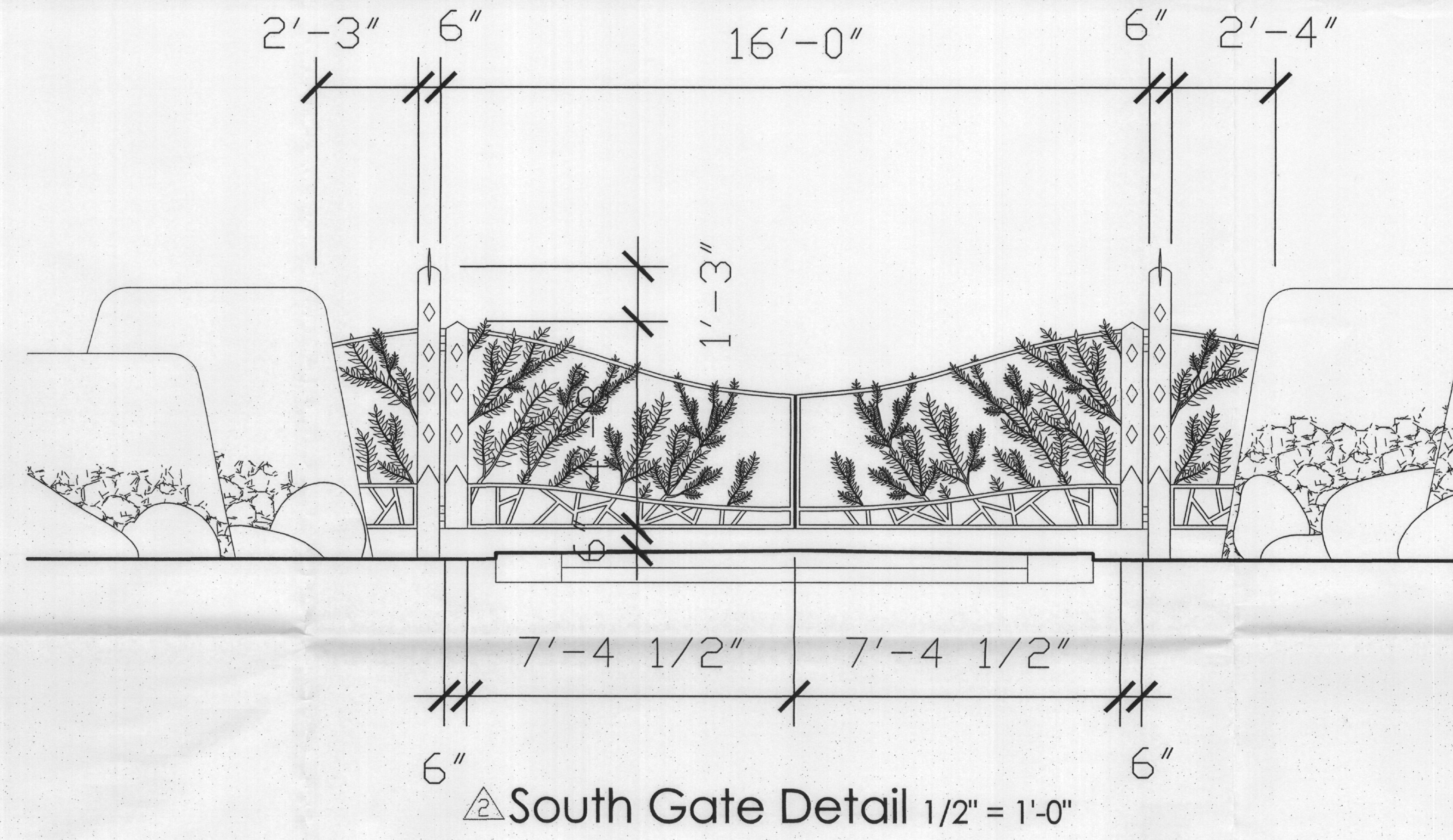
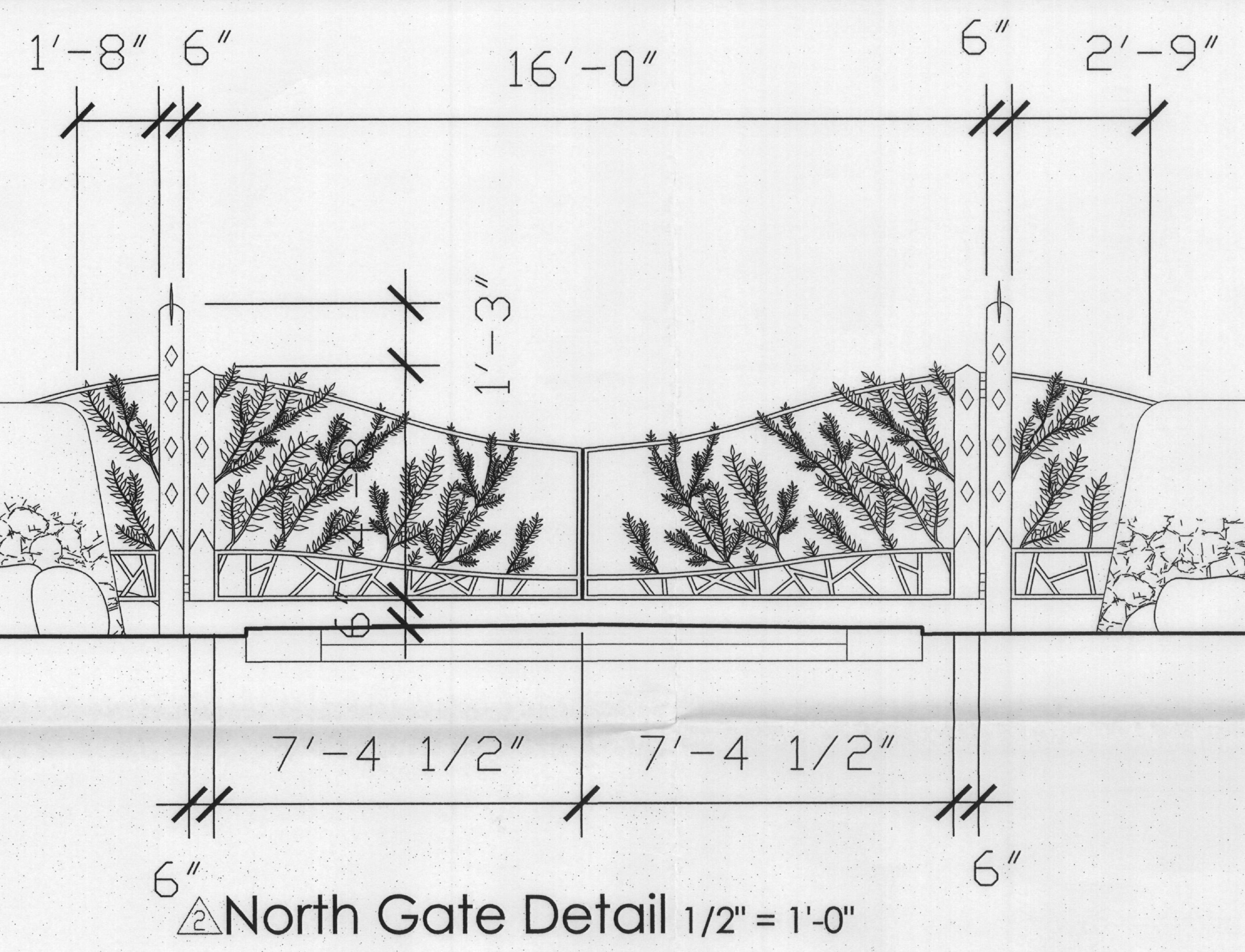



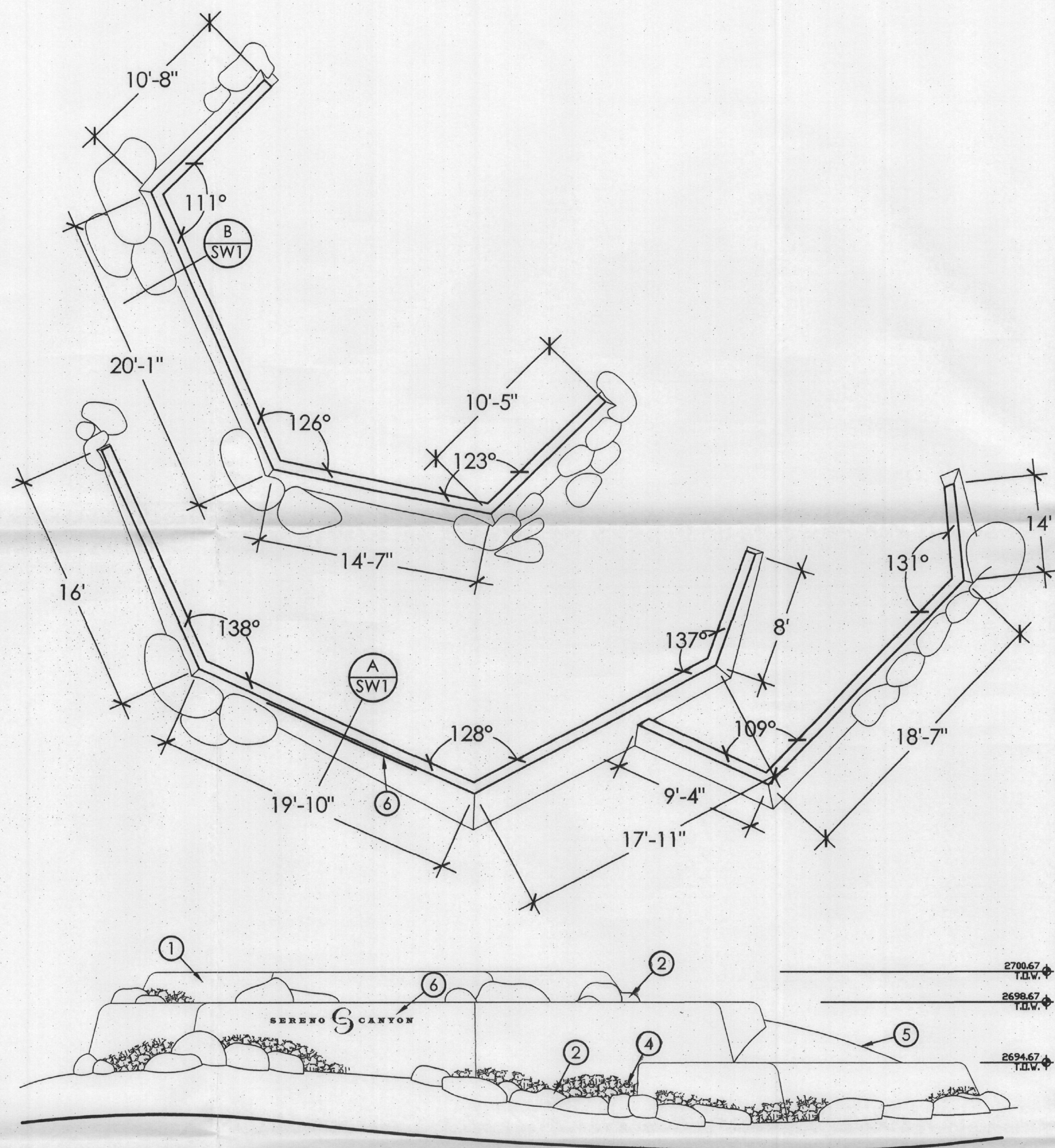

Ⓒ Main Entry Signage 3/16" = 1-0

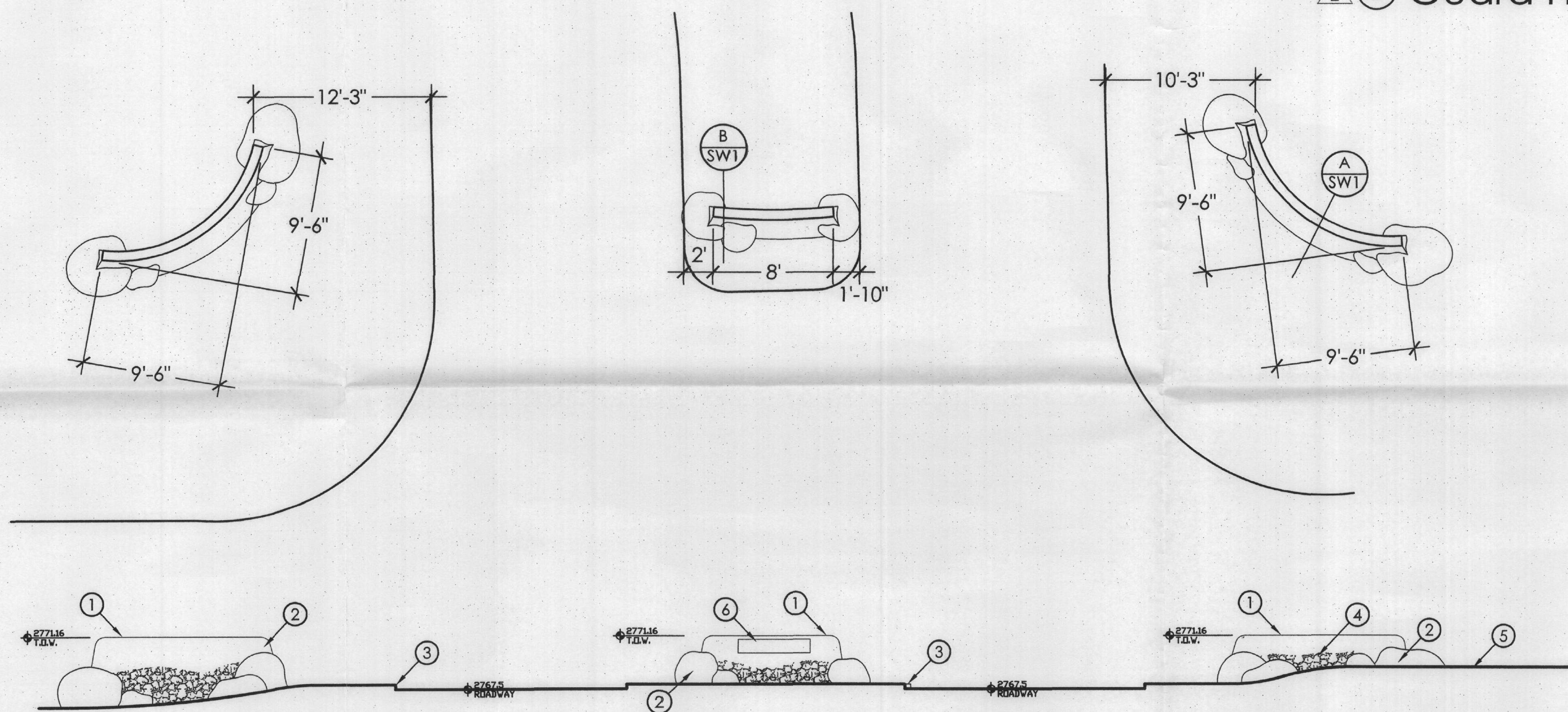

Ⓓ Retreat Sign Walls 3/16" = 1'-0"

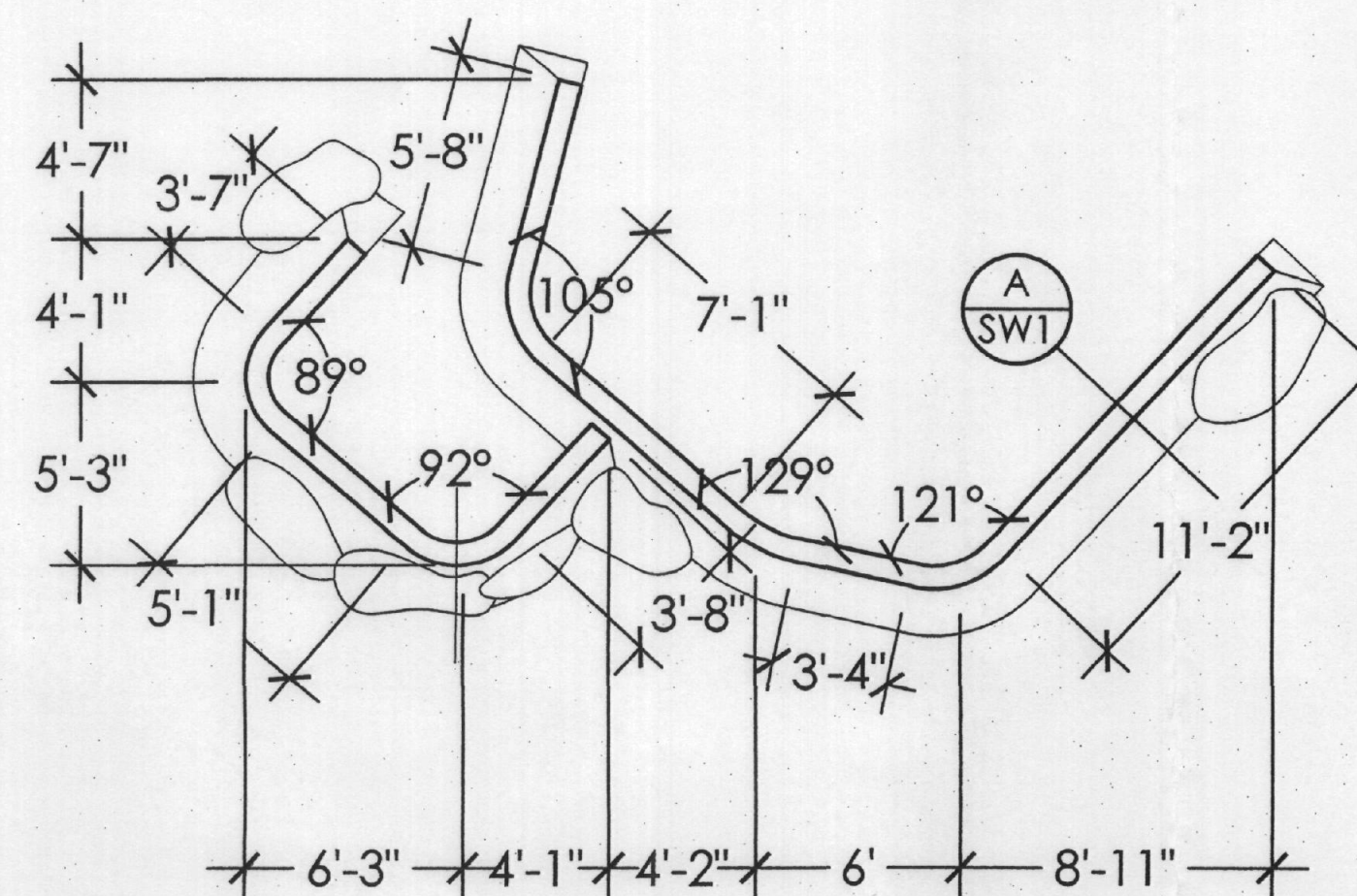

Ⓐ Guard House Site Walls 3/16" = 1-0

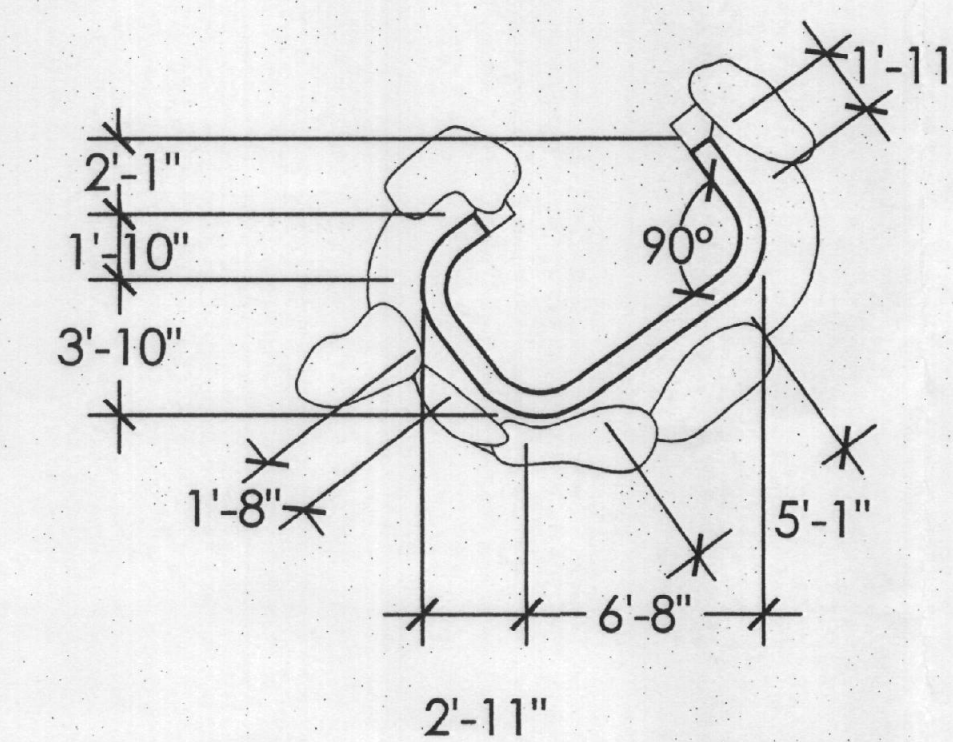

Ⓑ Guard House Site Walls 3/16" = 1-0

KEYNOTES:

1. 8" CMU SITEWALLS W/ INTEGRALLY COLORED, TROWELED FINISH ELASTOMERIC STUCCO. COLOR TO BE SIMILAR TO DUNN EDWARDS DE 6201 RATTAN BASKET LRV 27 TYPICAL UNLESS NOTED OTHERWISE. ALSO SEE DETAIL.
2. NATURAL SITE HARVESTED BOULDERS INTEGRATED WITH THE WALL CONSTRUCTION. MUD SET VARIOUS SIZE. GENERAL CONTRACTOR SHALL COORDINATE EXACT PLACEMENT WITH ARCHITECT.
3. EDGE OF ROAD
4. NATURAL STONE VENEER SIMILAR TO APACHE STONES DC COBBLE. MUD SET MORTAR WASHED WITH COLORED MORTAR TO MATCH BUILDING COLOR.
5. FINISH GRADE
6. PROJECT SIGNAGE UNDER SEPARATE PERMIT

Craig Wickersham Inc. Architects  
15821 N. 79th Street  
Suite 2  
Scottsdale, AZ 85260  
480 609-6766

DISCLAIMER:  
These drawings are the property of Craig Wickersham Inc. and are not to be used for any other project without the written consent of Craig Wickersham Inc. The user of these drawings is responsible for obtaining all necessary permits and for coordinating with all other professionals involved in the project. The user of these drawings is also responsible for obtaining all necessary approvals from the appropriate authorities. The user of these drawings is also responsible for obtaining all necessary approvals from the appropriate authorities. The user of these drawings is also responsible for obtaining all necessary approvals from the appropriate authorities.

REVISIONS:

NO.	DATE	DESCRIPTION
1	DEC 18 2007	ISSUED FOR PERMIT
2	JAN 2008	REVISIONS

GENERAL NOTES:

- A. SEE STRUCTURAL CALCULATIONS FOR STRUCTURAL ENGINEERING ON SITE WALLS, TYP.

1655-07-3  
APPROVED  
FINAL PLANS PLANNING  
DATE 1-16-08  
113-DE-2005 #2 30-5A-2008  
0 8 16 24

Sereno Canyon  
Crown Community Development  
Scottsdale, Arizona

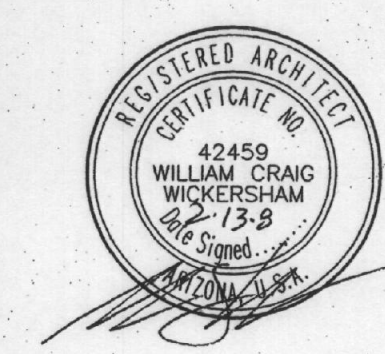

JOB NO. 0702  
DATE DEC 18 07  
SCALE AS SHOWN  
DRAWN S.J.R.  
CHECKED W.C.W.  
PLAN CHECK NO.  
1655-07-02



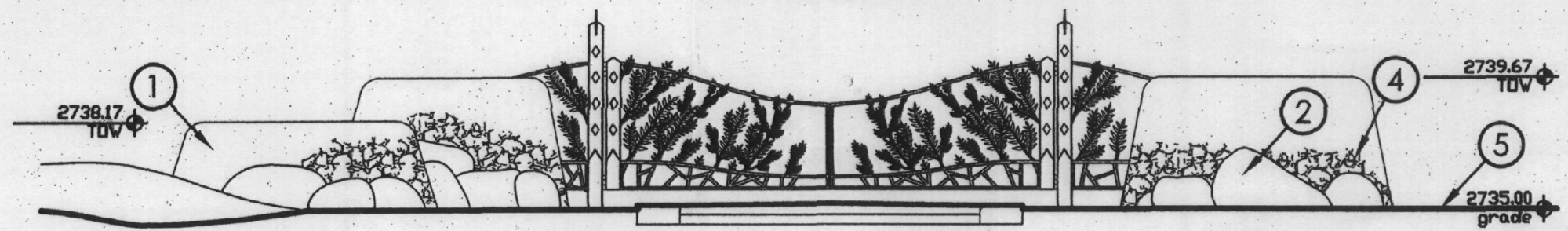
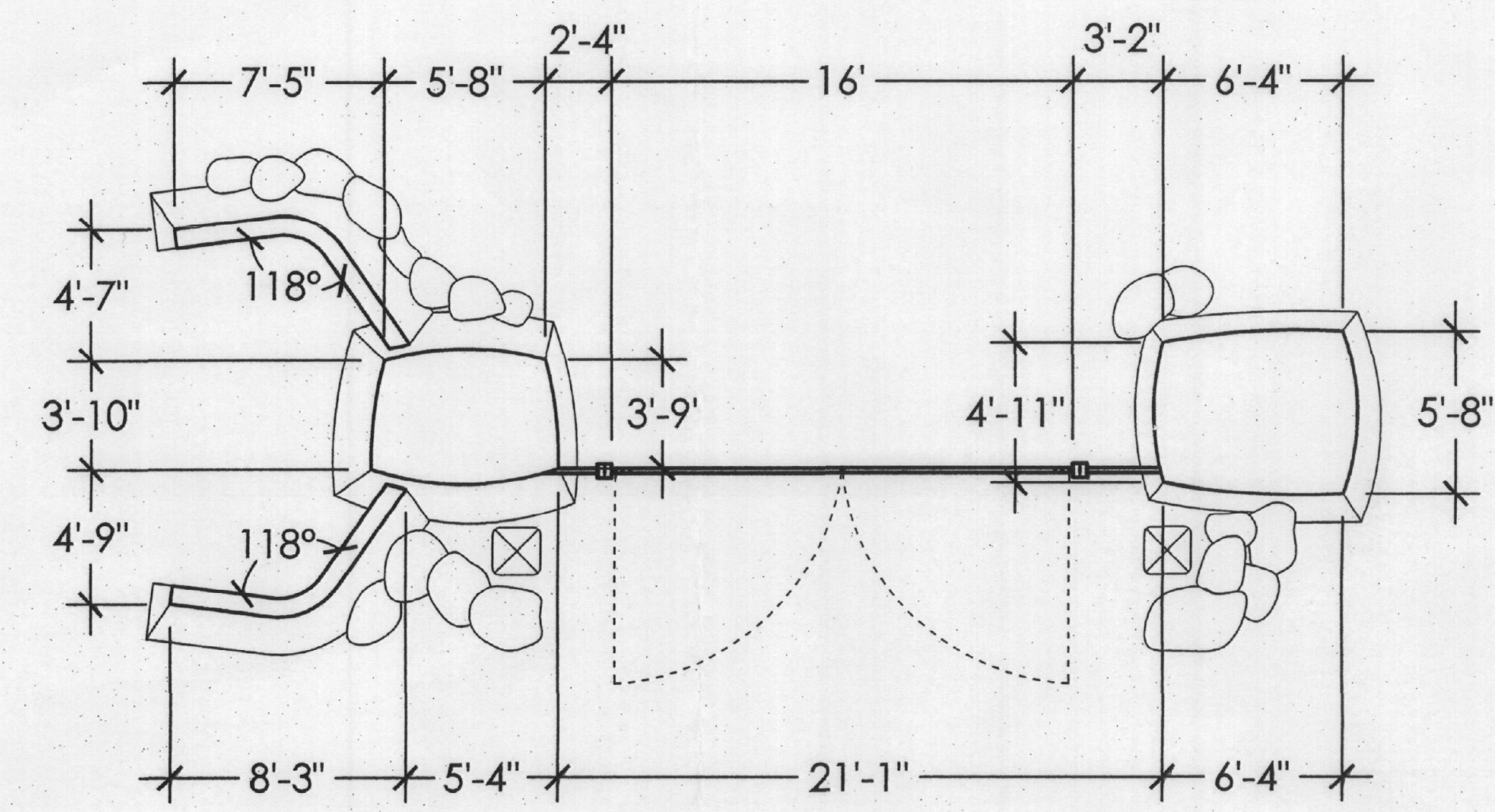

Ⓐ ⓓ Alameda Exit Site Walls 3/16" = 1'-0"

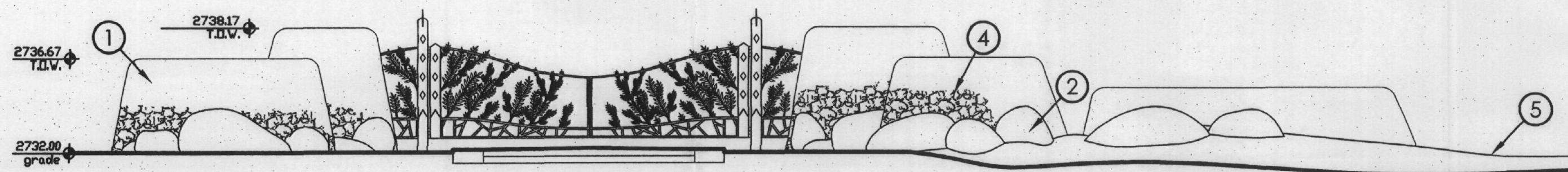
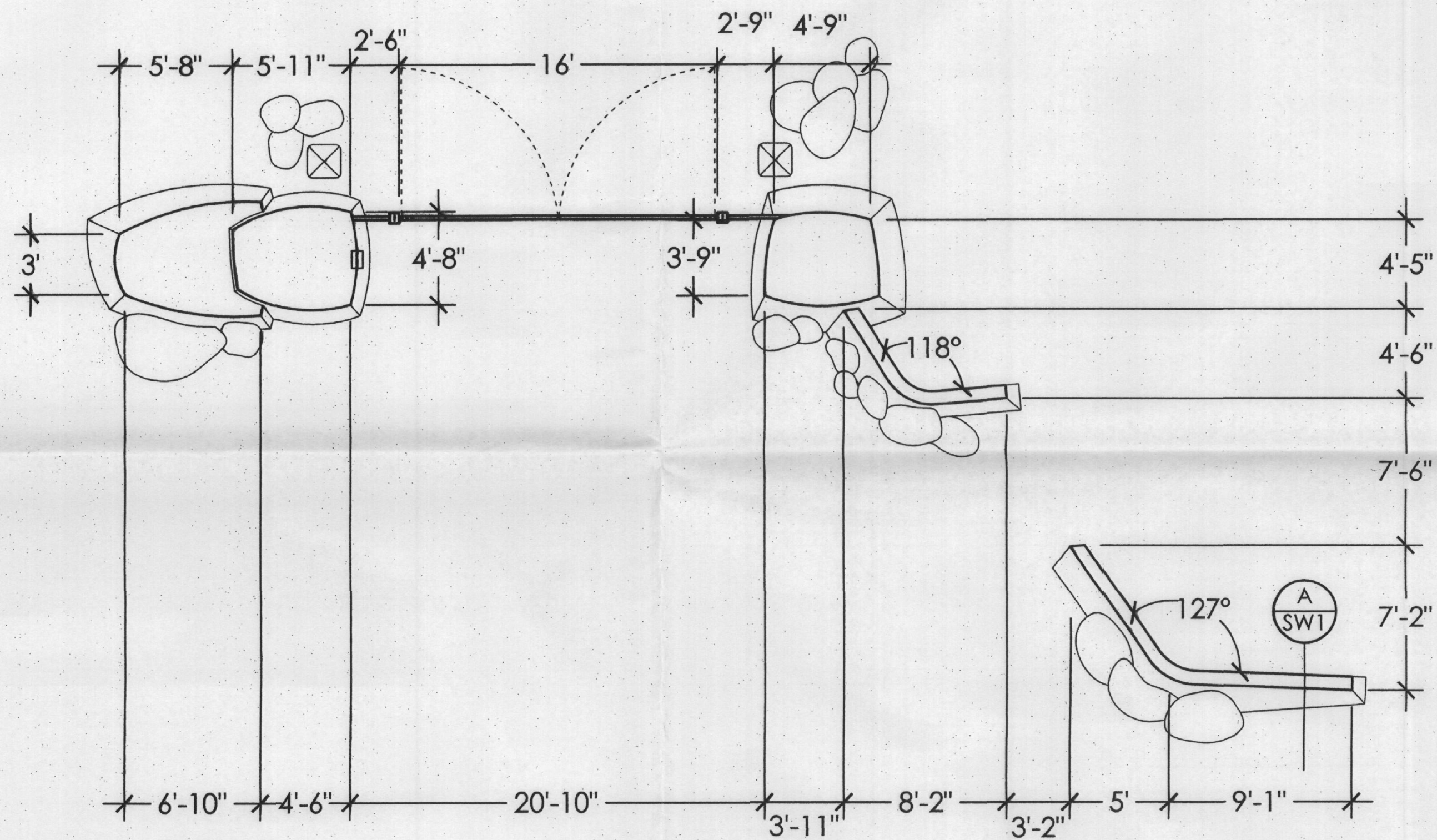

Ⓐ ⓔ Alameda Entrance Site Walls 3/16" = 1'-0"

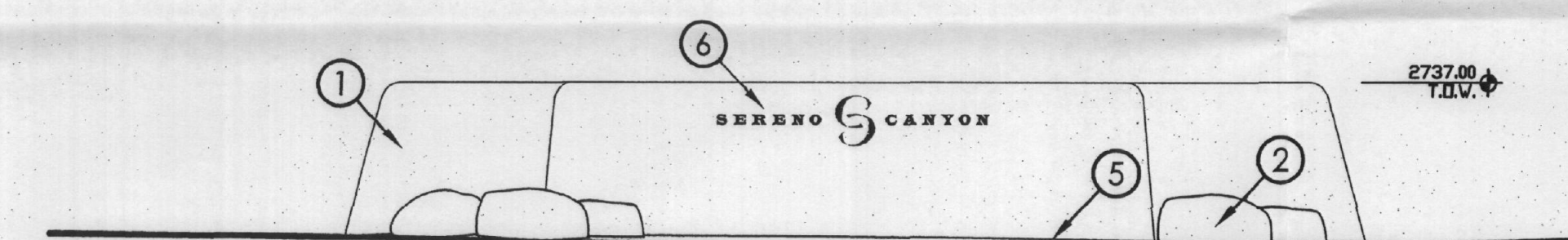
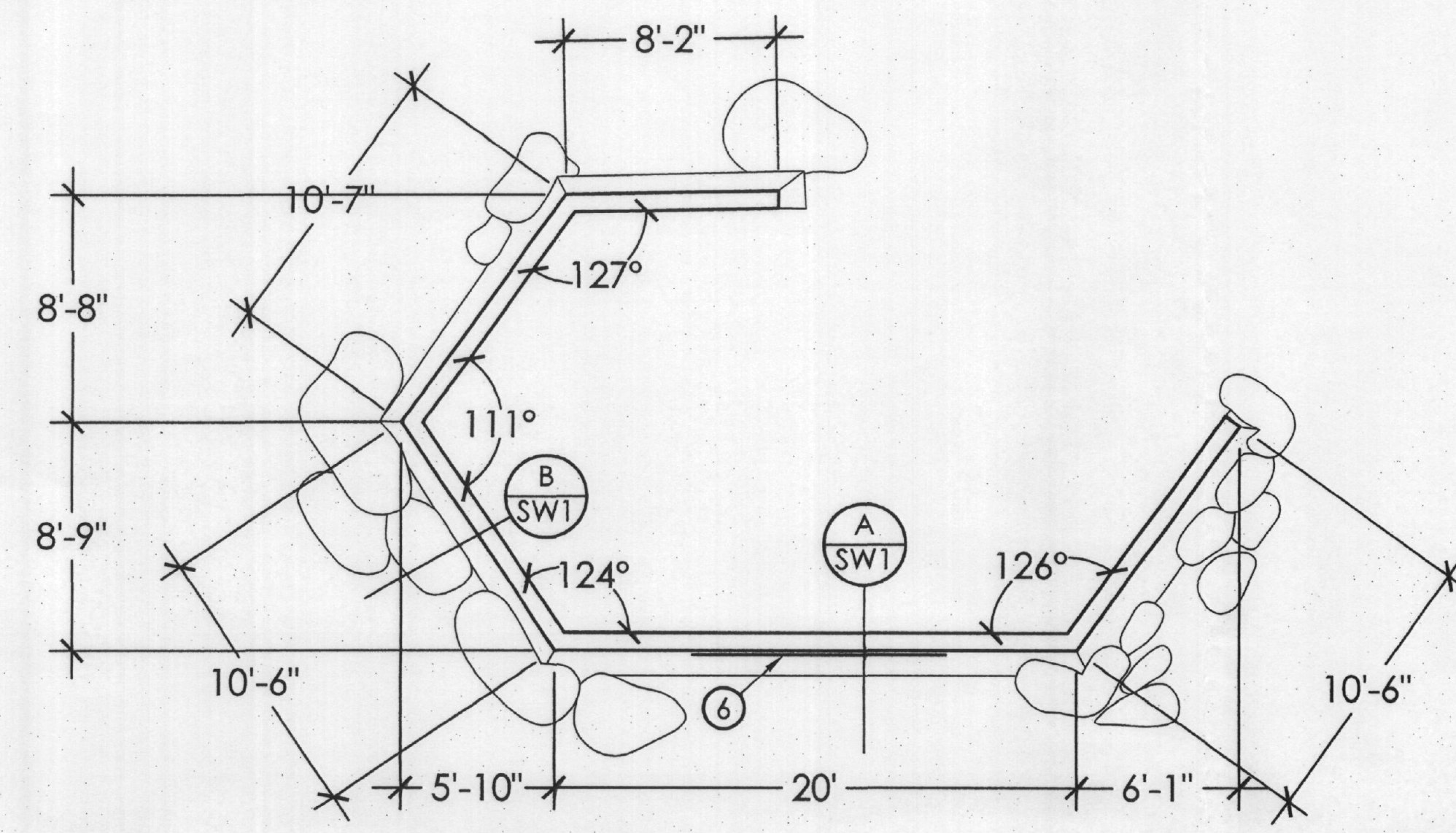

Ⓐ ⓐ Alameda Entrance Site Walls 3/16" = 1-0

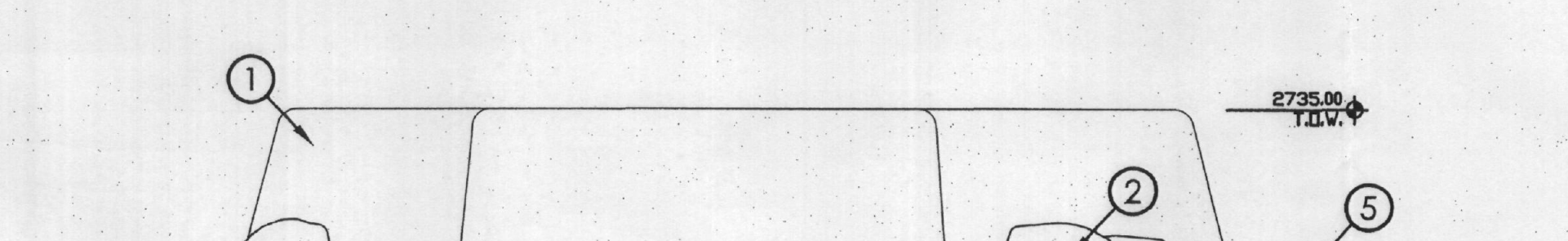
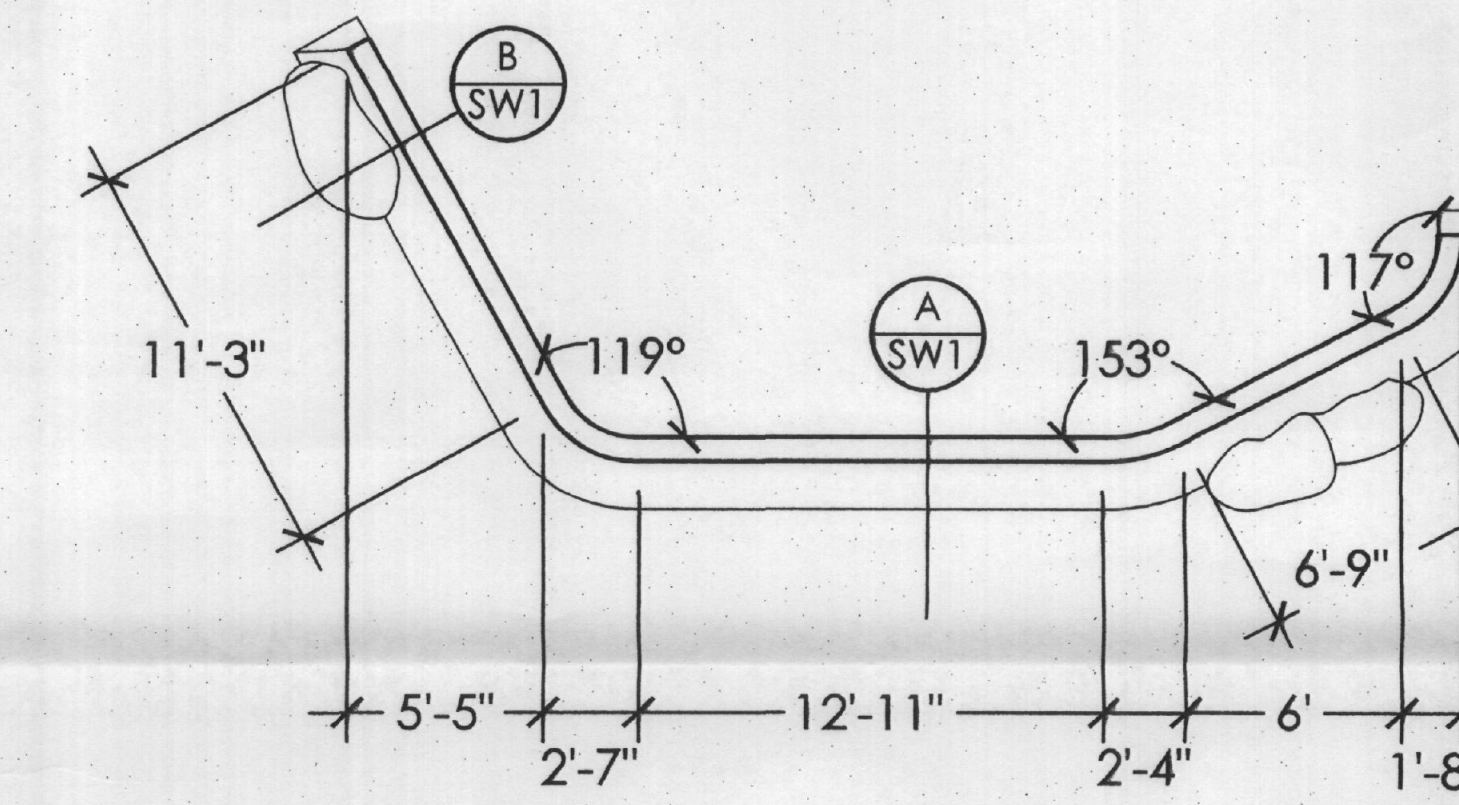

Ⓐ ⓑ Alameda Entrance Site Walls 3/16" = 1-0

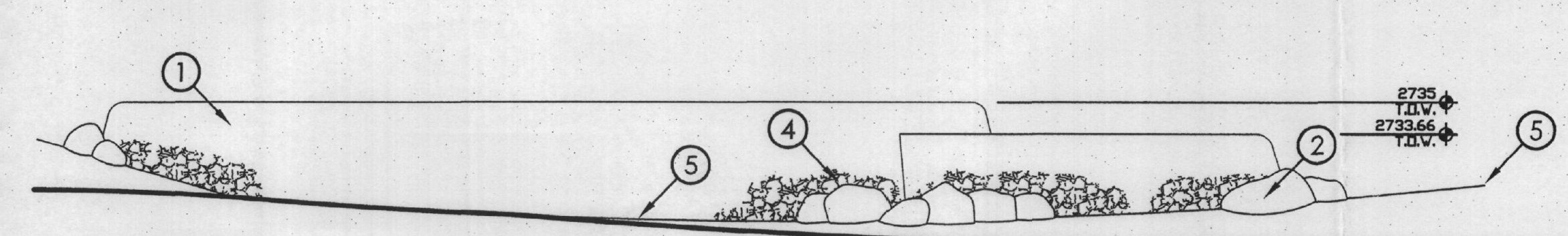
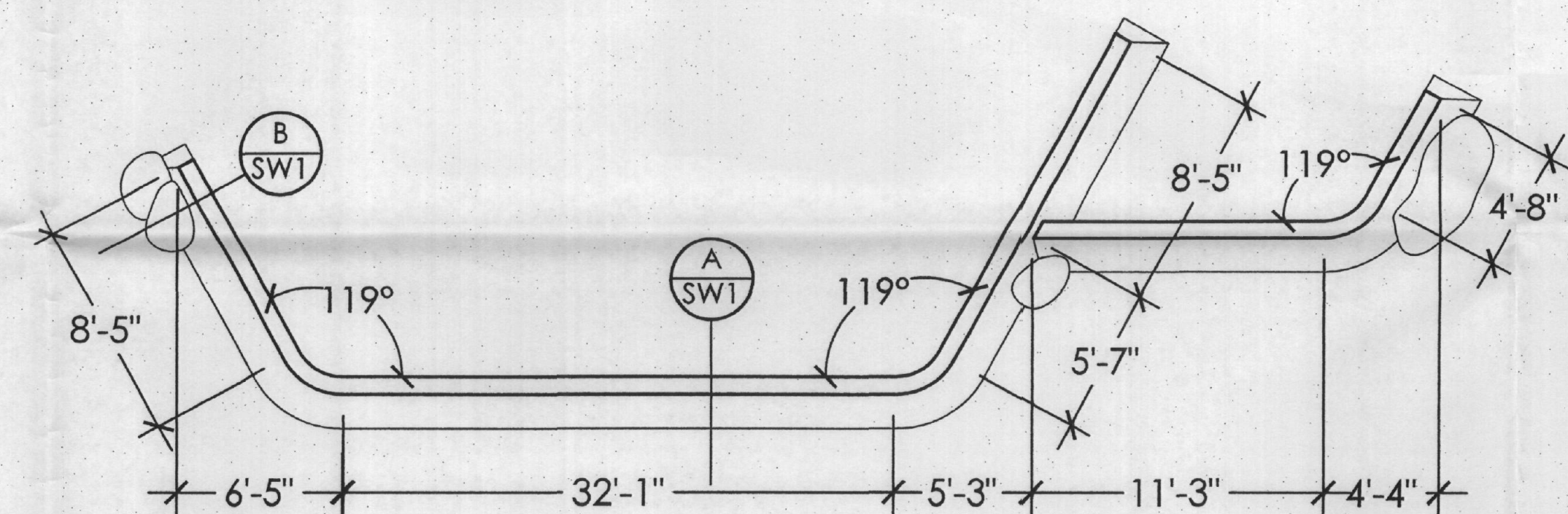

Ⓐ Ⓒ Alameda Entrance Site Walls 3/16" = 1-0

- KEYNOTES:**
- 8" CMU SITEWALLS W/ INTEGRALLY COLORED, TROWELED FINISH ELASTOMERIC STUCCO. COLOR TO BE SIMILAR TO DUNN EDWARDS DE 6201 RATTAN BASKET LRV 27 TYPICAL UNLESS NOTED OTHERWISE. ALSO SEE DETAIL.
  - NATURAL SITE HARVESTED BOULDERS INTEGRATED WITH THE WALL CONSTRUCTION. MUD SET VARIOUS SIZE. GENERAL CONTRACTOR SHALL COORDINATE EXACT PLACEMENT WITH ARCHITECT.
  - EDGE OF ROAD
  - NATURAL STONE VENEER SIMILAR TO APACHE STONE'S DC COBBLE. MUD SET MORTAR WASHED WITH COLORED MORTAR TO MATCH BUILDING COLOR.
  - FINISH GRADE
  - PROJECT SIGNAGE UNDER SEPARATE PERMIT

Craig Wickersham Inc. Architects  
15821 N. 79th Street  
Suite 2  
Scottsdale, AZ 85260  
480 609-6766

**DISCLAIMER:**  
These drawings are the property of Craig Wickersham Inc. and shall remain the property of Craig Wickersham Inc. No part of these drawings shall be reproduced or transmitted in any form or by any means, electronic, mechanical, photocopying, recording, or by any information storage and retrieval system, without the prior written permission of Craig Wickersham Inc.

**REVISIONS:**

NO.	DATE	DESCRIPTION
1	DEC 18 2007	ISSUED FOR PERMIT
2	JAN 2008	OWNER

**Sereno Canyon**  
Crown Community Development  
Scottsdale, Arizona

**GENERAL NOTES:**

- SEE STRUCTURAL CALCULATIONS FOR STRUCTURAL ENGINEERING ON SITE WALLS, TYP.

1655-07-3  
**APPROVED**  
FINAL PLANS PLANNING  
4-16-08  
DATE  
1/3-02-2008 #2 50-SA-2008  
SCALE: AS SHOWN  
DRAWN: S.R.  
CHECKED: W.C.W.  
PLAN CHECK NO.

0 8 16 24

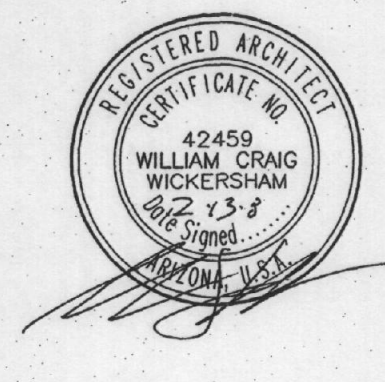

JOB NO. 0702 SHEET NO. SW3  
DATE: DEC 18 07  
SCALE: AS SHOWN  
DRAWN: S.R.  
CHECKED: W.C.W.  
PLAN CHECK NO. 1655-07-02