

5 AS-BUILT IMAGE
S2

N.T.S.

10 YEAR UV WARRANTY
POLYTEX™ 230
PREMIUM FIRE RATED SHADE FABRIC

TECHNICAL SPECIFICATIONS

Color Range	Warp		Weft	
	UVA	UVB	Mean UPF	Shade Factor
Aquamarine	92.5%	92.5%	14	55%
Black	96.9%	96.9%	33	97%
Bronze	90.4%	90.3%	10	80%
Claret	89.6%	91.7%	11	82%
Midnight Green	86.9%	84.9%	19	83%
Navy Blue	95.7%	95.9%	25	87%
Pomegranate	84.9%	85.7%	23	73%
Bluet	83.4%	83.7%	6	87%
Sage	92.4%	92.4%	3	85%
Sandstone	92.4%	92.4%	3	72%
Silver	84.5%	84.8%	7	87%
Slate	94.2%	94.3%	18	82%
White	91.0%	91.2%	17	69%

FIRE STANDARD COMPLIANT
POLYTEX™ is made to the following standards:
NFPA 701 - 1995
ASTM E-119 Class (A)
CAL 119
ASTM E-136 Class 1
ASTM E-136 Class 2
ASTM E-136 Class 3
ASTM E-136 Class 4
ASTM E-136 Class 5
ASTM E-136 Class 6
ASTM E-136 Class 7
ASTM E-136 Class 8
ASTM E-136 Class 9
ASTM E-136 Class 10
ASTM E-136 Class 11
ASTM E-136 Class 12
ASTM E-136 Class 13
ASTM E-136 Class 14
ASTM E-136 Class 15
ASTM E-136 Class 16
ASTM E-136 Class 17
ASTM E-136 Class 18
ASTM E-136 Class 19
ASTM E-136 Class 20
ASTM E-136 Class 21
ASTM E-136 Class 22
ASTM E-136 Class 23
ASTM E-136 Class 24
ASTM E-136 Class 25
ASTM E-136 Class 26
ASTM E-136 Class 27
ASTM E-136 Class 28
ASTM E-136 Class 29
ASTM E-136 Class 30
ASTM E-136 Class 31
ASTM E-136 Class 32
ASTM E-136 Class 33
ASTM E-136 Class 34
ASTM E-136 Class 35
ASTM E-136 Class 36
ASTM E-136 Class 37
ASTM E-136 Class 38
ASTM E-136 Class 39
ASTM E-136 Class 40
ASTM E-136 Class 41
ASTM E-136 Class 42
ASTM E-136 Class 43
ASTM E-136 Class 44
ASTM E-136 Class 45
ASTM E-136 Class 46
ASTM E-136 Class 47
ASTM E-136 Class 48
ASTM E-136 Class 49
ASTM E-136 Class 50
ASTM E-136 Class 51
ASTM E-136 Class 52
ASTM E-136 Class 53
ASTM E-136 Class 54
ASTM E-136 Class 55
ASTM E-136 Class 56
ASTM E-136 Class 57
ASTM E-136 Class 58
ASTM E-136 Class 59
ASTM E-136 Class 60
ASTM E-136 Class 61
ASTM E-136 Class 62
ASTM E-136 Class 63
ASTM E-136 Class 64
ASTM E-136 Class 65
ASTM E-136 Class 66
ASTM E-136 Class 67
ASTM E-136 Class 68
ASTM E-136 Class 69
ASTM E-136 Class 70
ASTM E-136 Class 71
ASTM E-136 Class 72
ASTM E-136 Class 73
ASTM E-136 Class 74
ASTM E-136 Class 75
ASTM E-136 Class 76
ASTM E-136 Class 77
ASTM E-136 Class 78
ASTM E-136 Class 79
ASTM E-136 Class 80
ASTM E-136 Class 81
ASTM E-136 Class 82
ASTM E-136 Class 83
ASTM E-136 Class 84
ASTM E-136 Class 85
ASTM E-136 Class 86
ASTM E-136 Class 87
ASTM E-136 Class 88
ASTM E-136 Class 89
ASTM E-136 Class 90
ASTM E-136 Class 91
ASTM E-136 Class 92
ASTM E-136 Class 93
ASTM E-136 Class 94
ASTM E-136 Class 95
ASTM E-136 Class 96
ASTM E-136 Class 97
ASTM E-136 Class 98
ASTM E-136 Class 99
ASTM E-136 Class 100

SOLARFAB
WWW.SOLARFAB.COM
SMART FABRIC SOLUTIONS IN ENVIRONMENTAL CONTROL

1 FABRIC (FIRE RESISTANCE)
S2 N.T.S.

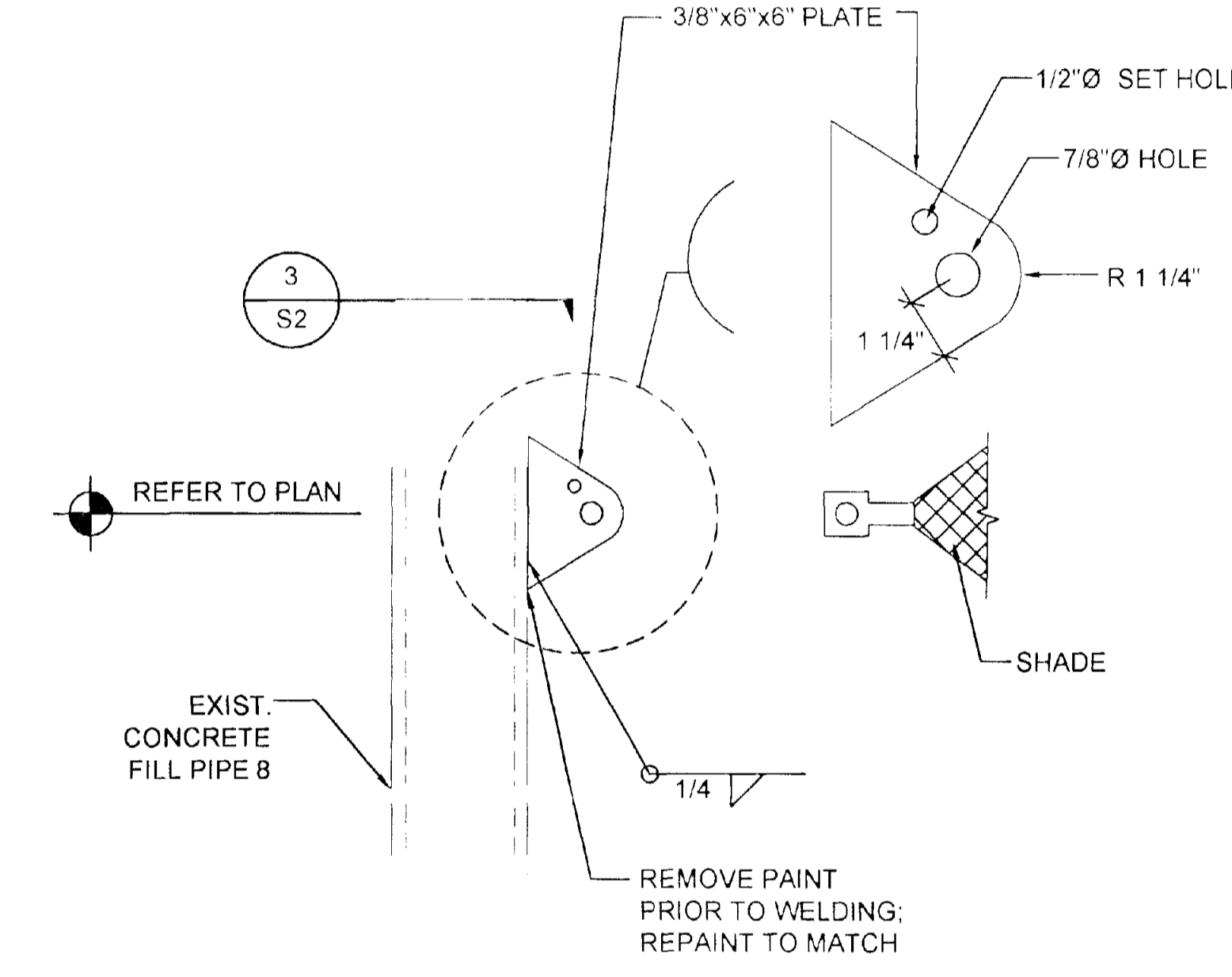

2 FABRIC CABLE SYSTEM CONNECTION TO POLE
S2 N.T.S.

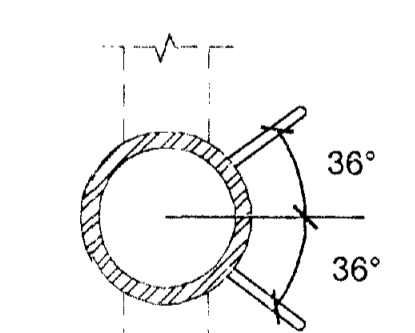

3 PLATE LAYOUT
S2 N.T.S.

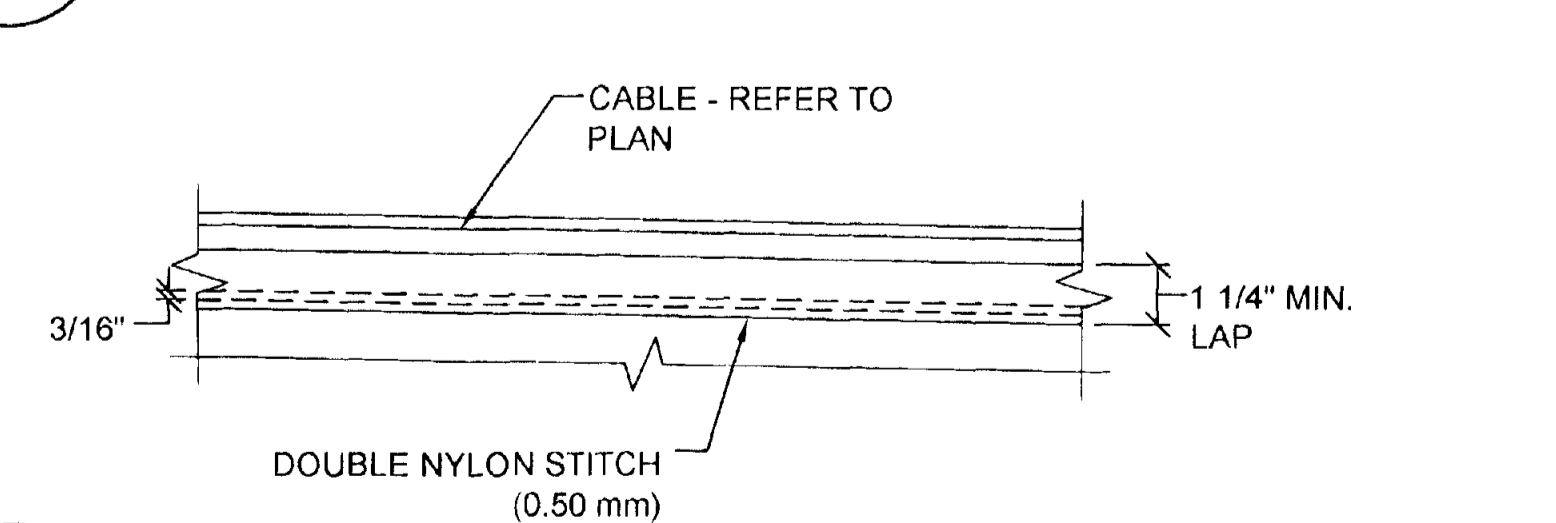

4 SHADE ATTACHMENT TO CABLES
S2 N.T.S.

3260 NORTH HAYDEN ROAD
SUITE 108
SCOTTSDALE, AZ 85251
PH: 480-425-2250
FX: 480-425-2225

TRUKTUR
STUDIO

URBAN SHADOW

W HOTEL
SHADE STRUCTURE
7277 EAST CAMELBACK
SCOTTSDALE, AZ 85251

REVISIONS

NO.	DESCRIPTION	DATE

OWNERSHIP OF DOCUMENTS
DRAWINGS AND SPECIFICATIONS AS INSTRUMENTS OF SERVICE ARE AND SHALL REMAIN THE PROPERTY OF THE ENGINEER WHETHER THE PROJECT FOR WHICH THEY WERE PREPARED IS EXECUTED OR NOT. THEY ARE NOT TO BE USED ON OTHER PROJECTS OR EXTENSIONS TO THIS PROJECT EXCEPT BY AGREEMENT IN WRITING AND WITH APPROPRIATE COMPENSATION TO STRUKTUR STUDIO, L.L.C.

SHEET TITLE
IMAGES AND DETAILS

JOB NUMBER: 100207
DRAWN BY: TB
CHECKED BY: DL
ISSUE DATE: 04/28/10

Professional Engineer
35222
DAVID P. LUNENG
State of Arizona
Arizona, U.S.A.

SHEET NUMBER
S2

\\s2\1\1000\100207\THE W HOTEL\STRUCTURE\100207-PLAN_DETAILS.dwg
PLN 28 04/28/10 10:28:10