

Simulations
Photos
All Graphics (no plans)



Photo 1

15-DR-2017
3/30/2017



Photo 2



Photo 3



Photo 4



Photo 5



Photo 6



Photo 7

Photo 8





Photo 9

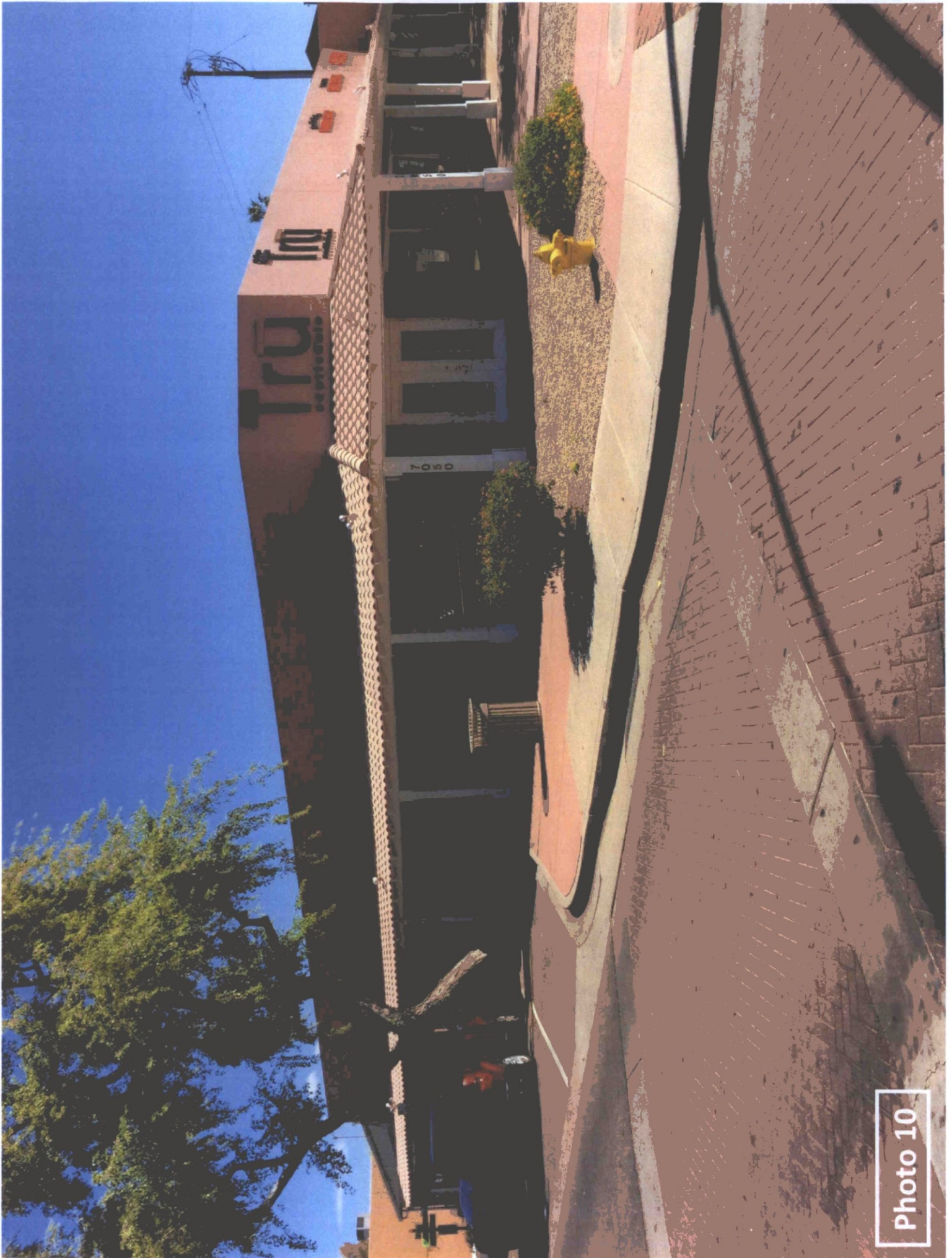

Photo 10



Photo 11

Photo 12

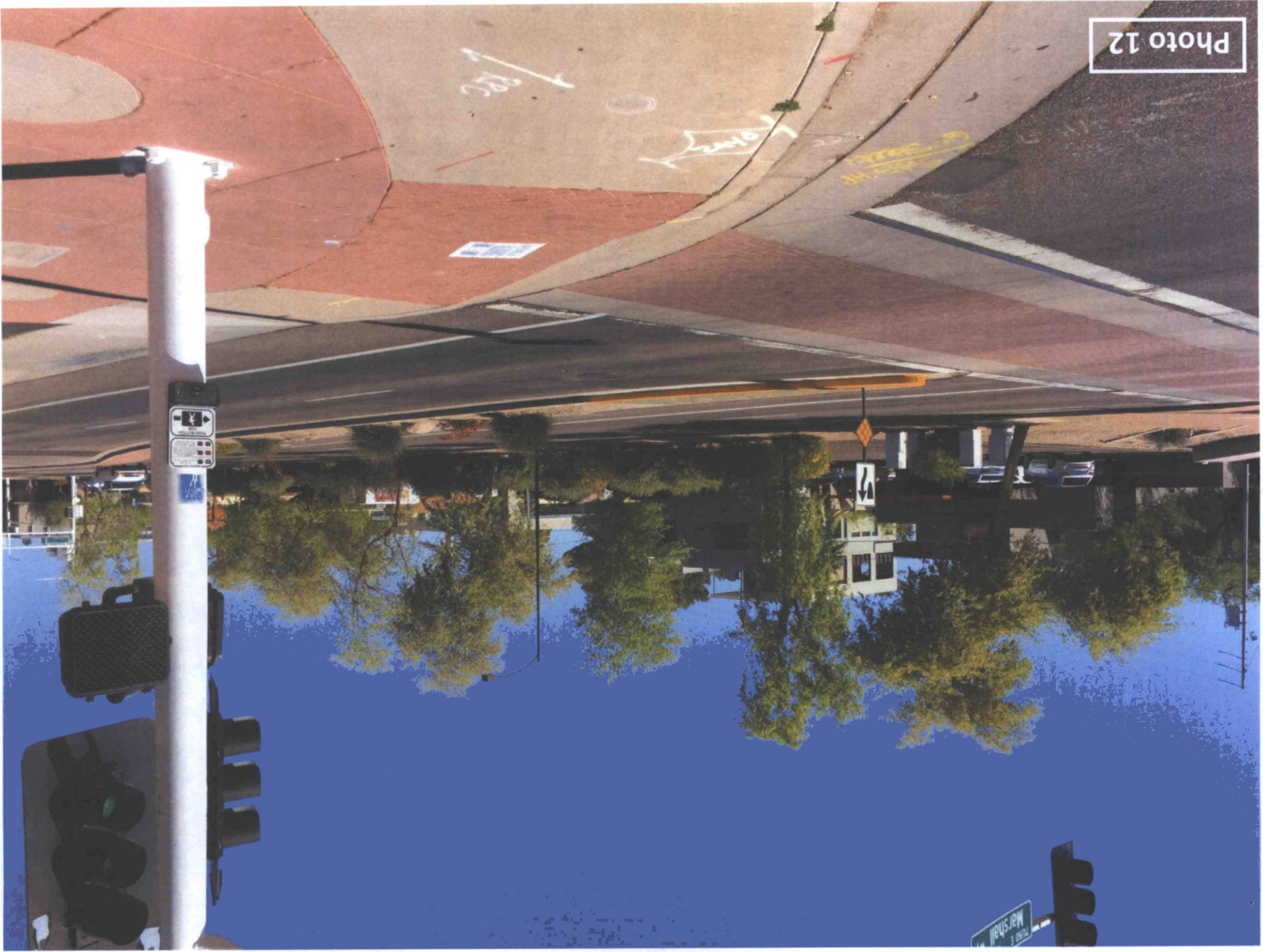



Photo 13



Photo 14

Photo 15



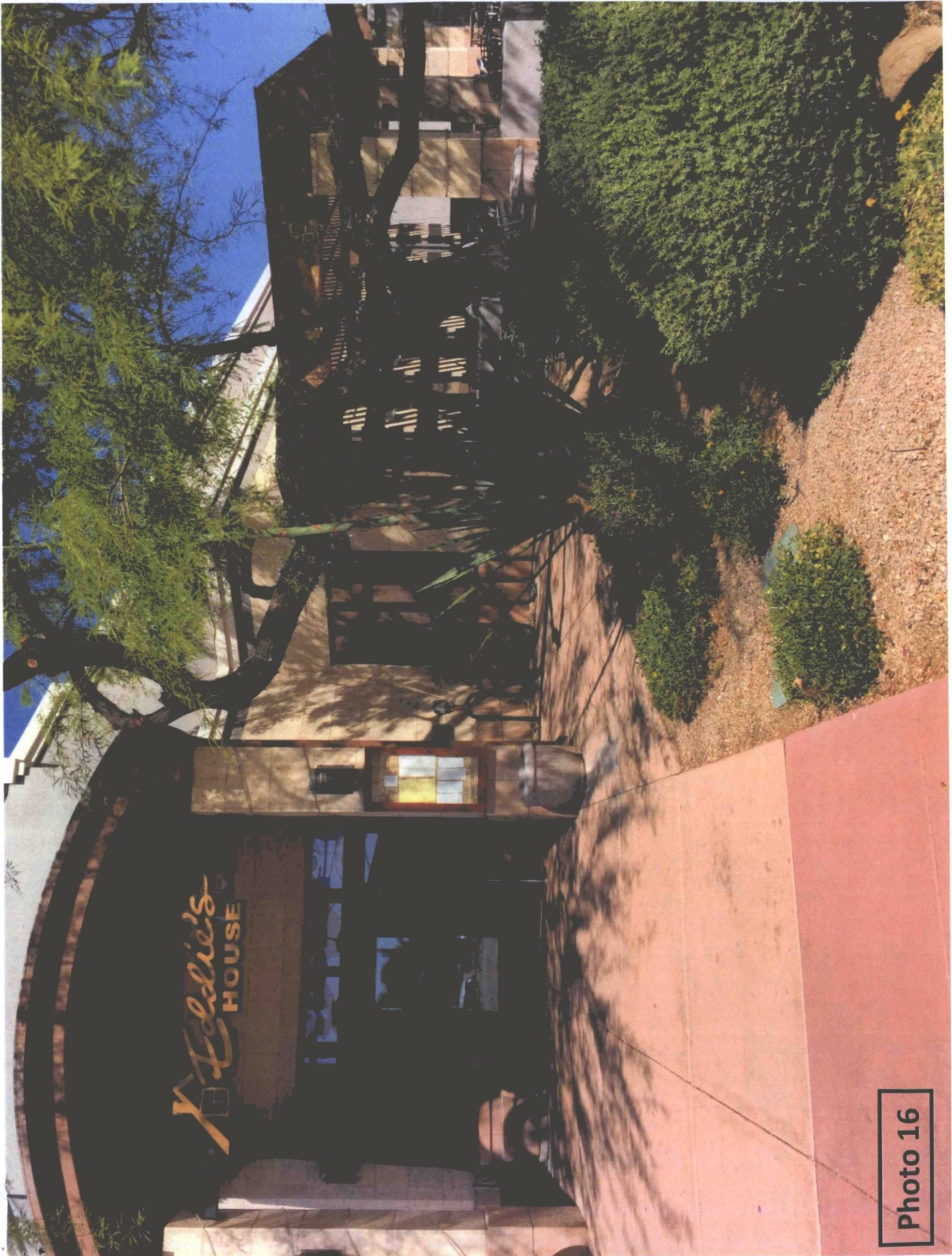
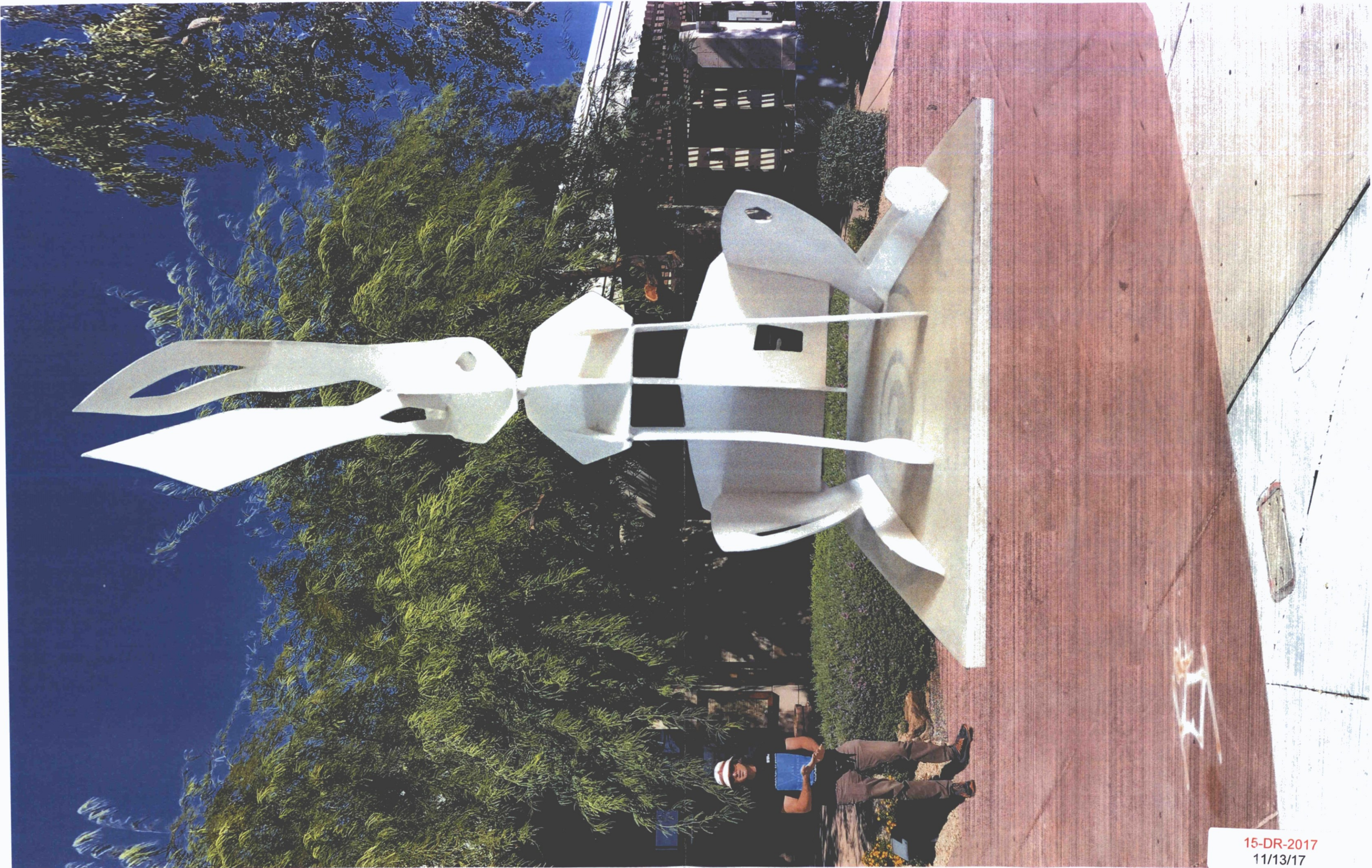
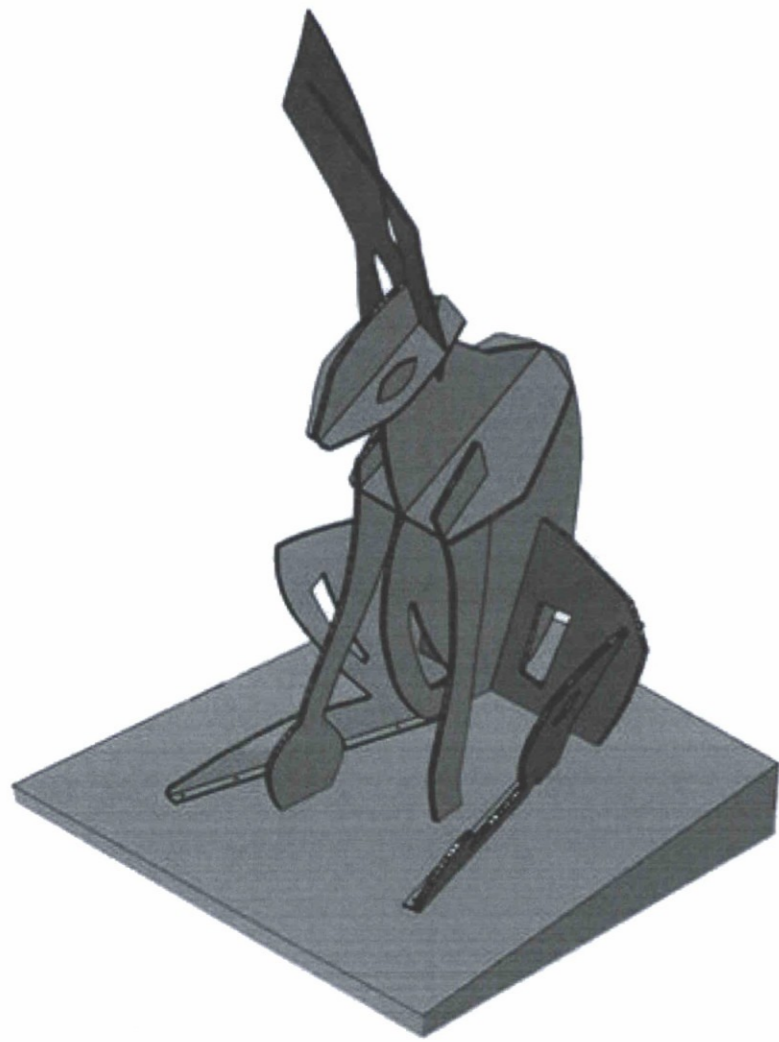

Photo 16



15-DR-2017
11/13/17



ISOMETRIC - FRONT

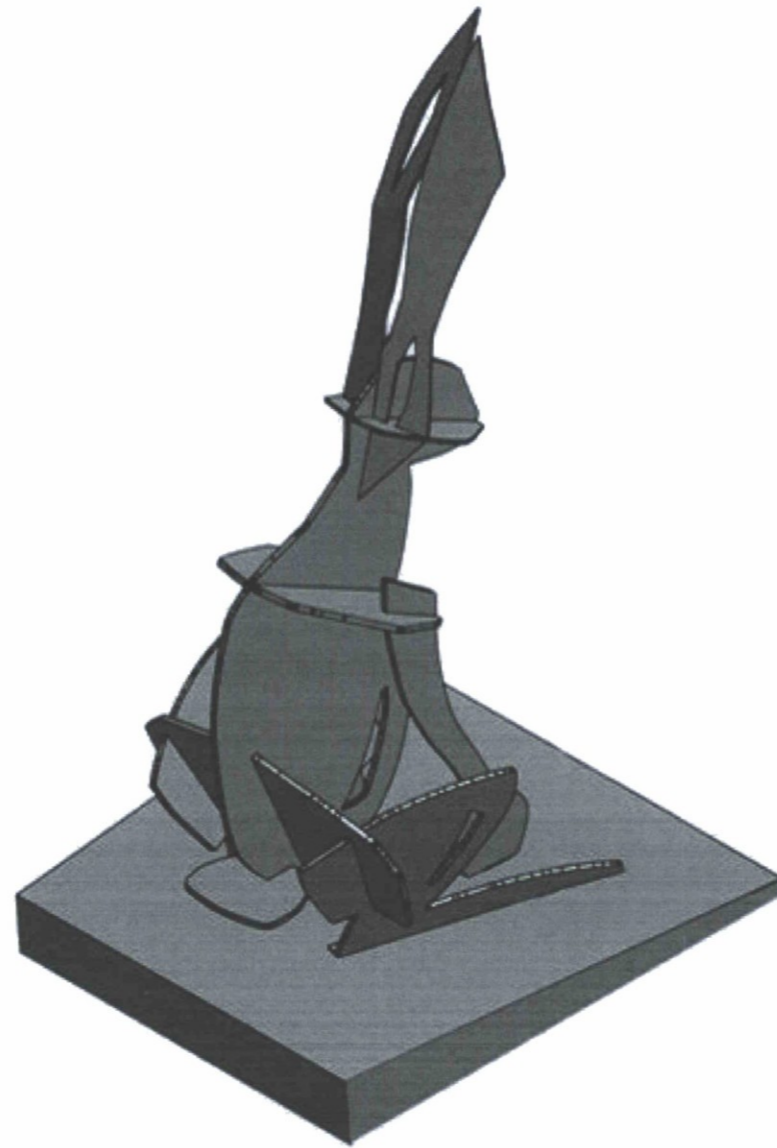

ISOMETRIC - REAR



SECTION ZZ-ZZ

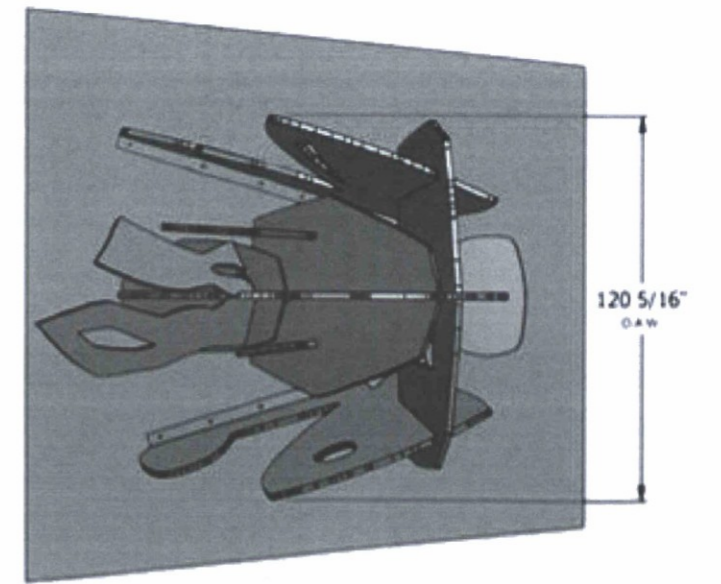

PLAN

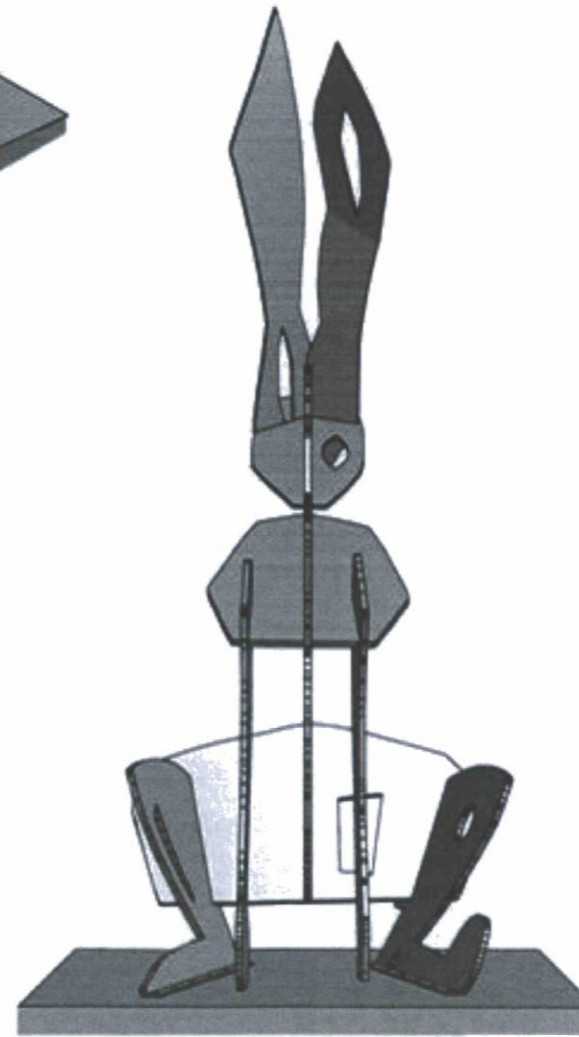

ELEVATION

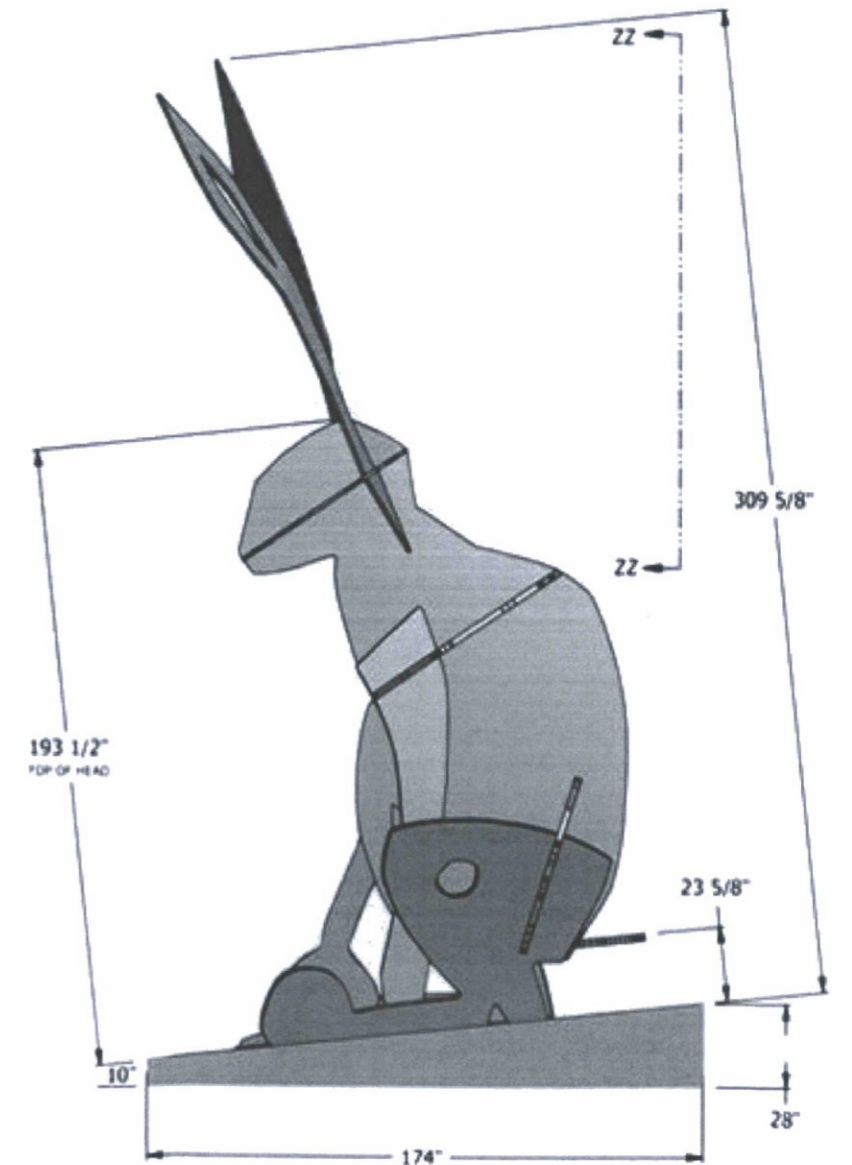

PROFILE

SONORAN JACK ASSEMBLY

REVISION 04

MATERIAL: ASTM A36 PLATE
WEIGHT: 20,800 LBS. (APPROX.)

