

SITE DATA	
GROSS AREA:	129.03 ACRES
NET AREA:	127.82 ACRES
EXISTING ZONING:	R-48/ESL
PROPOSED ZONING:	UNCHANGED
LOT COUNTS:	MOUNTAIN ESTATES 5
	MOUNTAIN HOUSE COTTAGES 29
	MOUNTAIN HOMES (60'x130') 129
	MOUNTAIN HOME DUPLEX (50'x100') 134
	TOTAL 297
GROSS DENSITY:	2.32 DU/AC
APNs: 217-01-010, 217-01-011A, 217-01-011C, 217-01-011D, 217-01-016F, 217-01-016K, 217-01-016L, 217-01-161, 217-01-162, 217-01-180 TO 217-01-189, 217-01-194 TO 217-01-199, 217-01-216, 217-01-217	

LEGEND	
	MATCHLINE
	PHASE LINE
	PARCEL LINE
	ROADWAY CENTERLINE
	RIGHT-OF-WAY
	LOT LINE
	BOUNDARY LINE
	CURB AND GUTTER
	EXISTING CURB AND GUTTER
	8" W PROPOSED WATER LINE
	8" S PROPOSED SEWER LINE
	8" W EXISTING WATER LINE
	8" S EXISTING SEWER LINE
	SS SANITARY SEWER MANHOLE
	(2800) EXISTING CONTOUR (5-FT)
	EXISTING CONTOUR (1-FT)
	2800 PROPOSED CONTOUR (5-FT)
	PROPOSED CONTOUR (1-FT)
	FIRE HYDRANT ASSEMBLY
	SITE VISIBILITY TRIANGLE
	ROCK OUTCROPPING
	RETAINING WALL
	FILL CUT CUT/FILL TRANSITION LINE
	2800 WSE WATER SURFACE ELEVATION
	89.82 PAD TOP OF CURB ELEVATION
	0.71% SLOPE FLOW ARROW
	EXISTING FLOW LINE
	LOT FLOW DIRECTION
	404 WASH
	HEAD WALL
	PROPOSED STORM PIPE 18" UNLESS OTHER WISE NOTED
	PROPOSED STORM DRAIN CATCH BASIN
	PROPOSED RETAINING WALL
	Q100 PEAK FLOW 9 CFS
	PROPOSED RIP-RAP

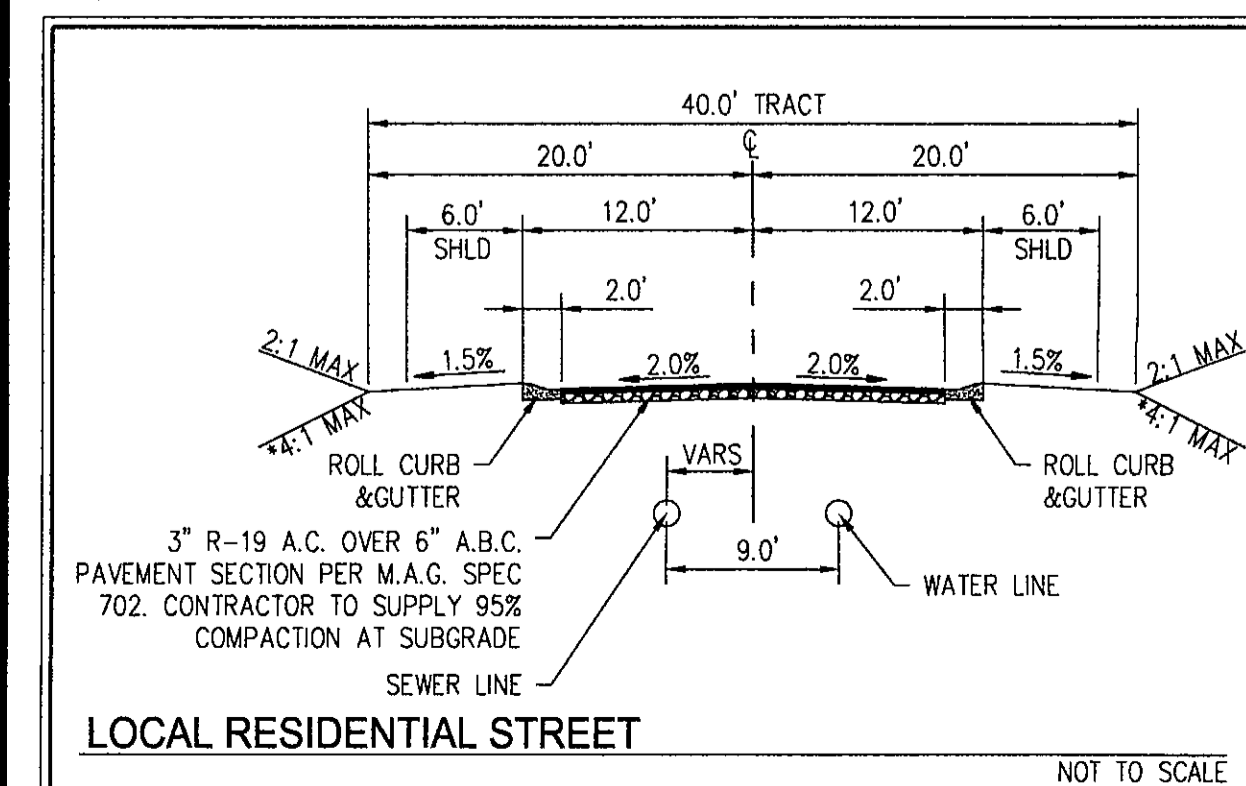
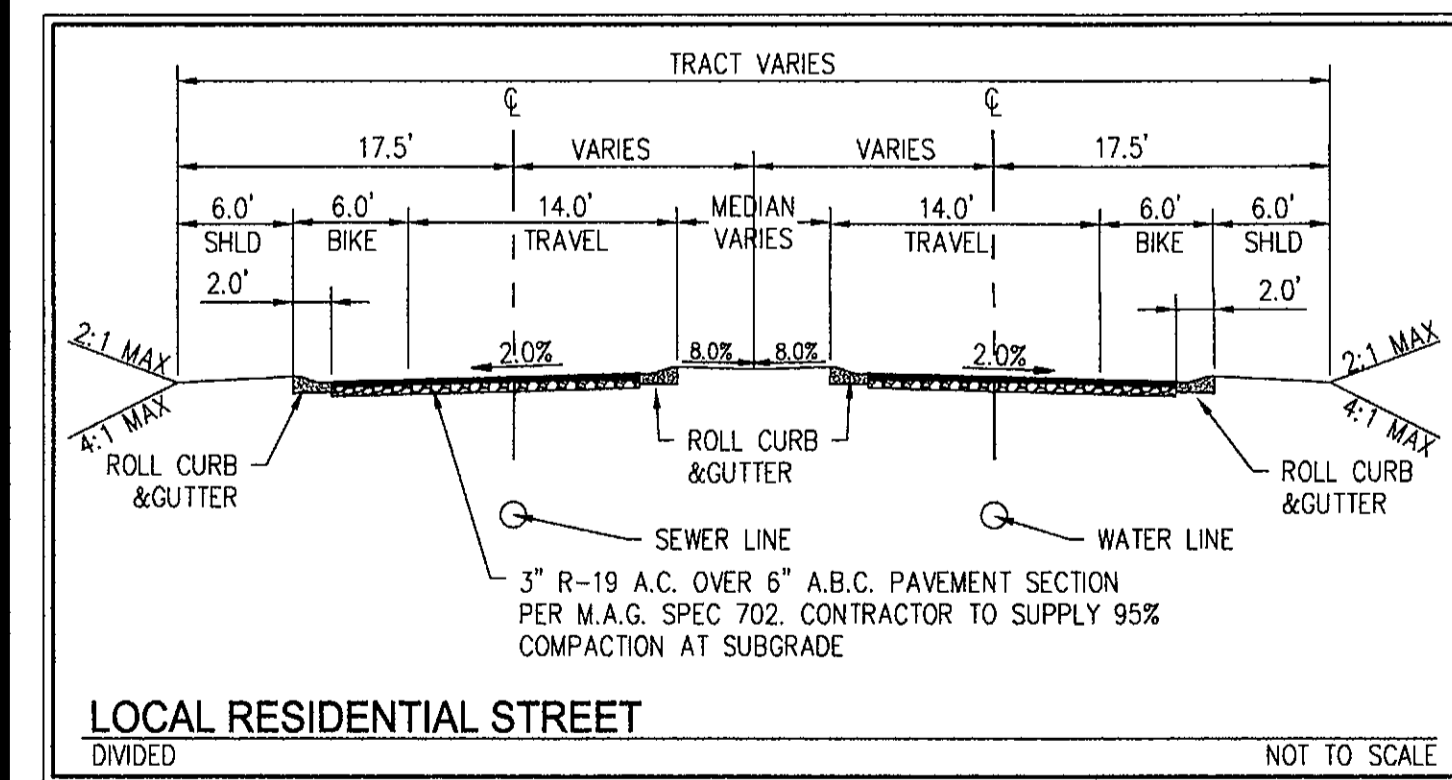

PRELIMINARY GRADING FOR SERENO CANYON PHASE 4 SCOTTSDALE, ARIZONA

125TH STREET & ALAMEDA RD.

A PORTION OF THE LAND LYING WITHIN SECTION 11, TOWNSHIP 4 NORTH, RANGE 5 EAST OF THE GILA AND SALT BASE AND MERIDIAN, MARICOPA COUNTY, ARIZONA

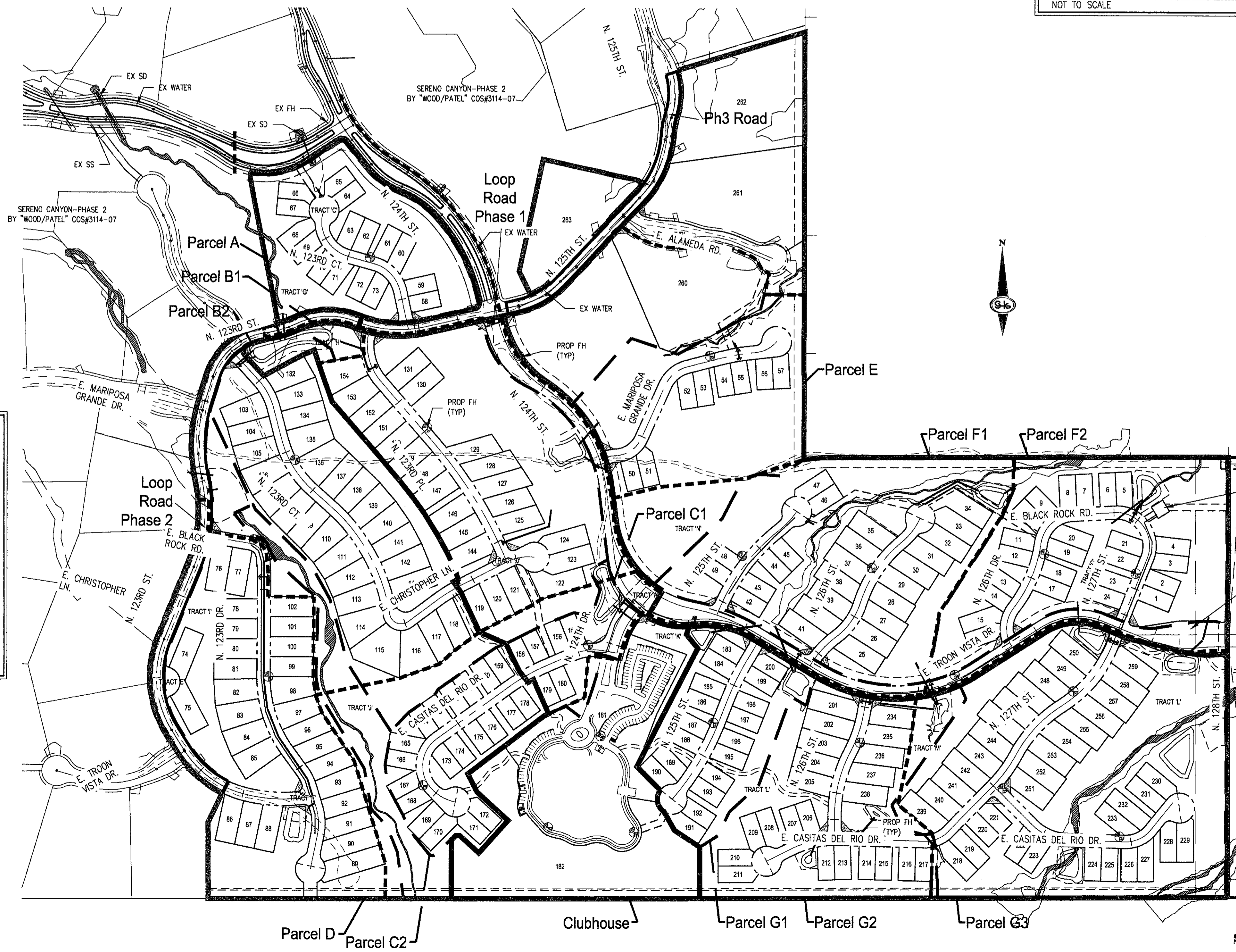
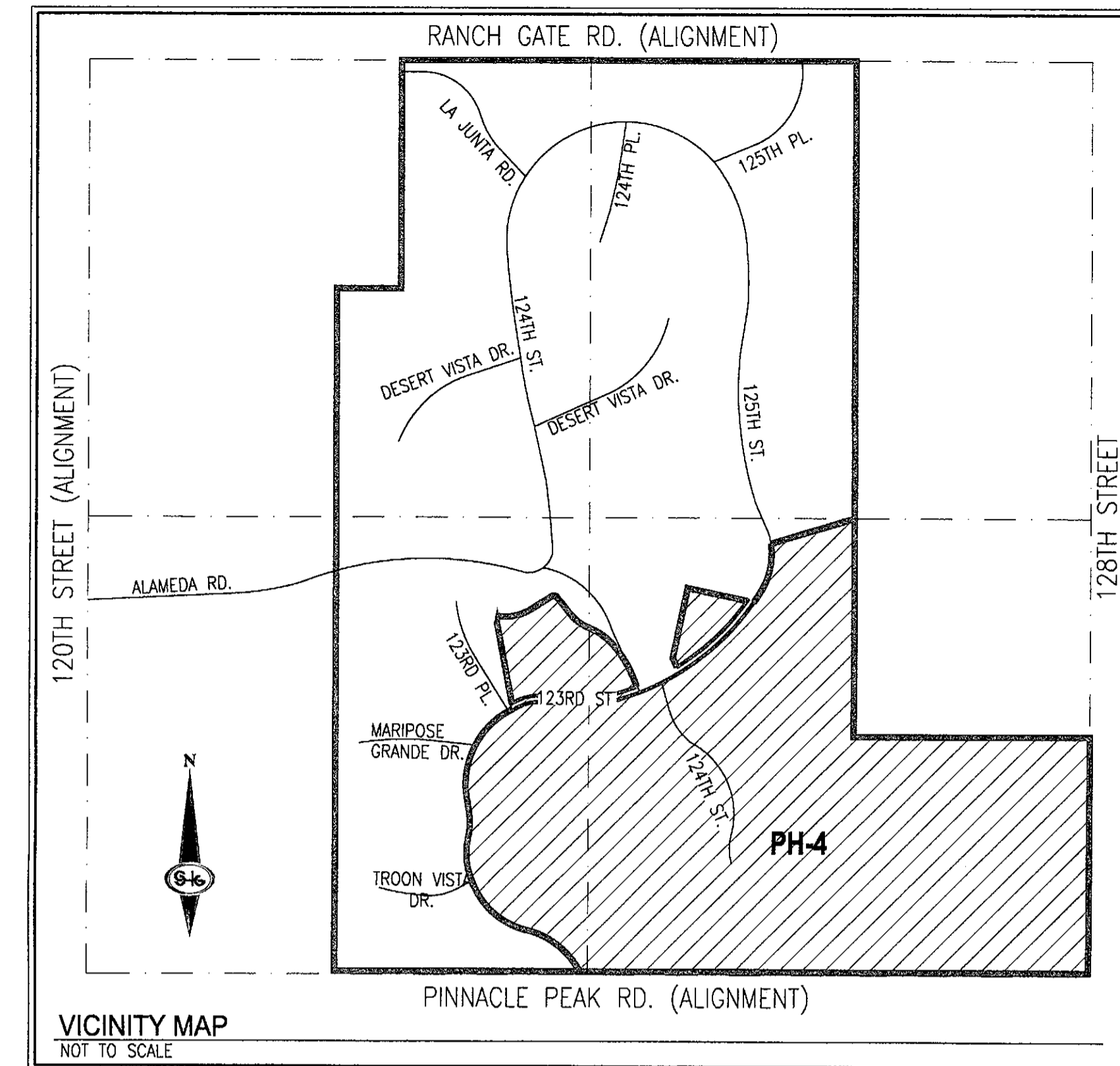

OWNER
CROWN COMMUNITY DEVELOPMENT
1751 WEST DIEHL RD. #A
NAPERVILLE, IL 60563
PHONE: 630-351-5490
CONTACT: MARVIN BAILEY
CONTACT EMAIL: M.BAILEY@CROWN-CHICAGO.COM

DEVELOPER
TOLL BROTHERS, INC
8767 E. VIA DE VENTURA, SUITE 390
SCOTTSDALE, AZ 85258
PHONE: 480-314-6711
CONTACT: OSCAR DOMINGUEZ
CONTACT EMAIL: ODOMINGUEZ@TOLLBROTHERS.COM

ENGINEER
SLATER HANIFAN GROUP
11201 N. TATUM BLVD., SUITE 250
PHOENIX, AZ 85028
PHONE: 602-687-9664
CONTACT: PATRICK LOWRY
CONTACT EMAIL: PLOWRY@SHG-INC.COM

LAND PLANNER
SWABACK PARTNERS
7550 E. McDONALD DR.
SCOTTSDALE, AZ 85250
PHONE: 480-367-2100
CONTACT: JEFF DENZAK
CONTACT EMAIL: JDENZAK@SWABACKPARTNERS.COM

SHEET INDEX

SHEET 01	- COVER SHEET
SHEET 02	- INDEX MAP, DETAILS & QUANTITIES
SHEETS 03-15	- PRELIMINARY GRADING PLANS

BASIS OF BEARING
THE EAST LINE OF THE SOUTHEAST ONE-QUARTER OF SECTION 11, TOWNSHIP 4 NORTH, RANGE 5 EAST PER THE GILA AND SALT RIVER BASE AND MERIDIAN, MARICOPA COUNTY, BEARING: S00°04'54"E

BENCHMARK
DESCRIPTION: CITY OF SCOTTSDALE BRASS CAP FLUSH: INTERSECTION OF HAPPY VALLEY DRIVE AND 120TH STREET FENCE RUNS S & W, UP 1.1' ELEVATION: 2,691.39' NAVD' 88 DATUM

16-PP-2017
05/07/18
M. Baronas 5/23/18
Date



SLATER HANIFAN GROUP
CONSULTING ENGINEERS & PLANNERS
11201 N. TATUM BOULEVARD #250, PHOENIX, AZ 85028
PHONE: (602) 687-9664

NO.	DESCRIPTION	DATE	BY	APC	APC

SCOTTSDALE, AZ

TOLL BROTHERS LAND DEVELOPMENT
SERENO CANYON PHASE 4
PRELIMINARY GRADING COVER SHEET

DATE: 03/26/2018
DRAFTER: SB
DESIGNER: GR/AAL
CHECKED: LB
PROJECT NO.
TOL1702-000

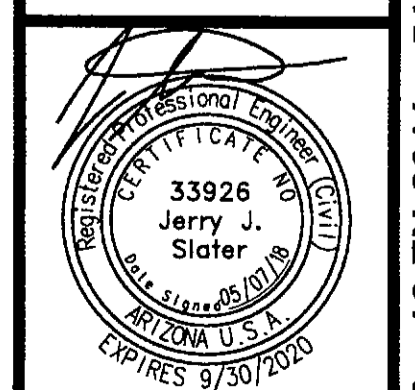

16-PP-2017
05/07/18
M. Baronas 5/23/18
Date

PG01
SHEET 1 OF 15

I:\1702-000-accrns\canyon phase 4\slater\hmf\preliminary grading\plan\1702-000-pre-accrns-01.dwg 5/7/2018 9:48 AM Ben. Ross

1-ZN-2005 #2 16-ZN-2011 51-DR-2017 16-PP-2017

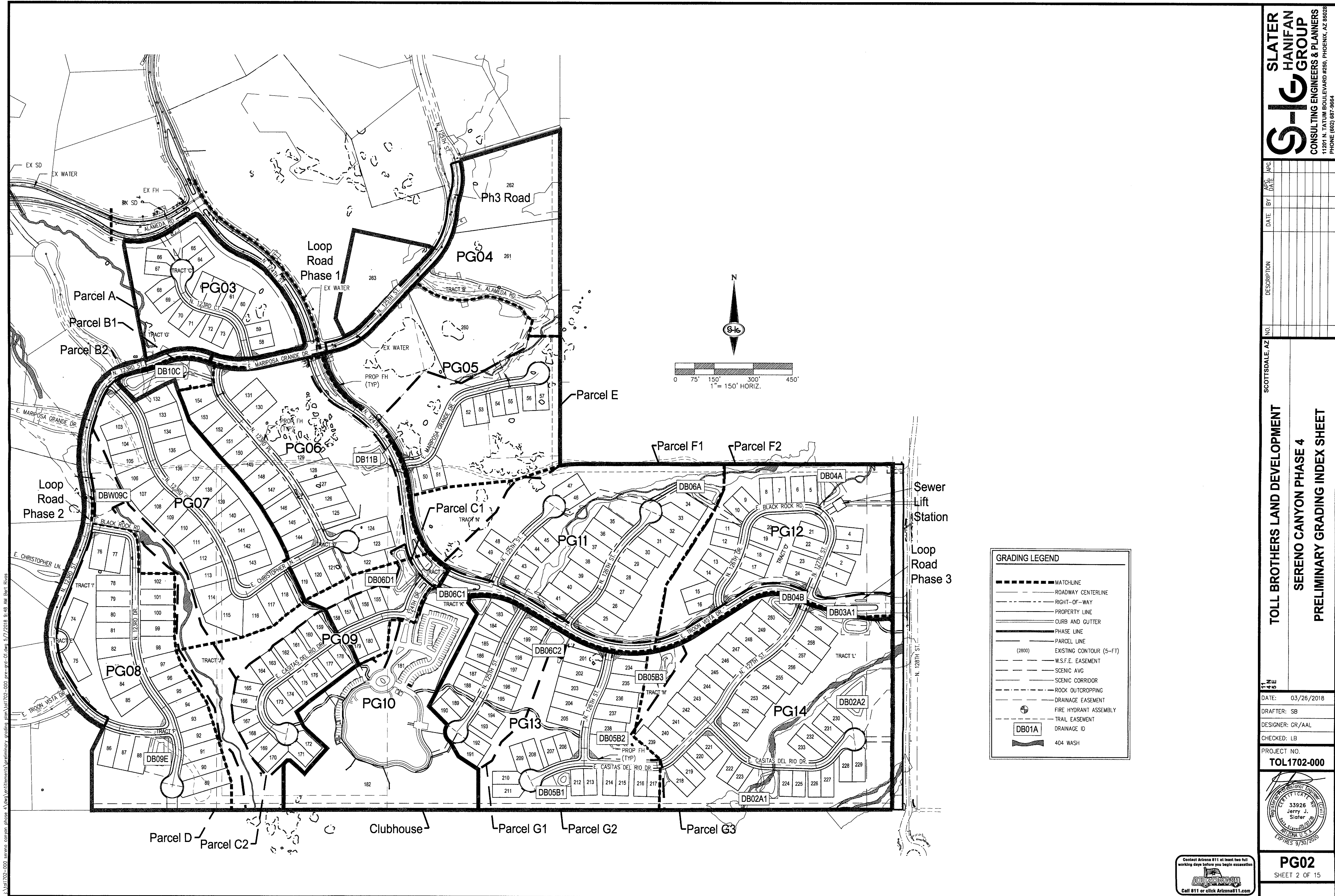

NO.	DESCRIPTION	DATE	BY	APC

SCOTTSDALE, AZ

TOLL BROTHERS LAND DEVELOPMENT
SERENO CANYON PHASE 4
PRELIMINARY GRADING INDEX SHEET

DATE: 03/26/2018
 DRAFTER: SB
 DESIGNER: GR/AAL
 CHECKER: LB
 PROJECT NO. **TOL1702-000**

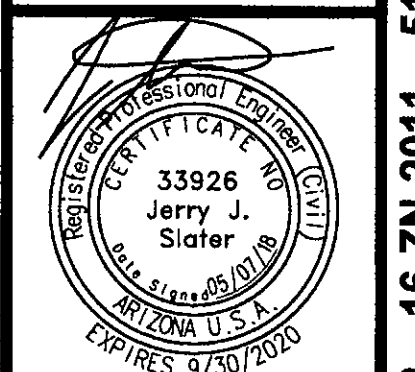



SEE VIEW ABOVE FOR SEWER TIE-IN

SEE VIEW BELOW FOR CONTINUATION

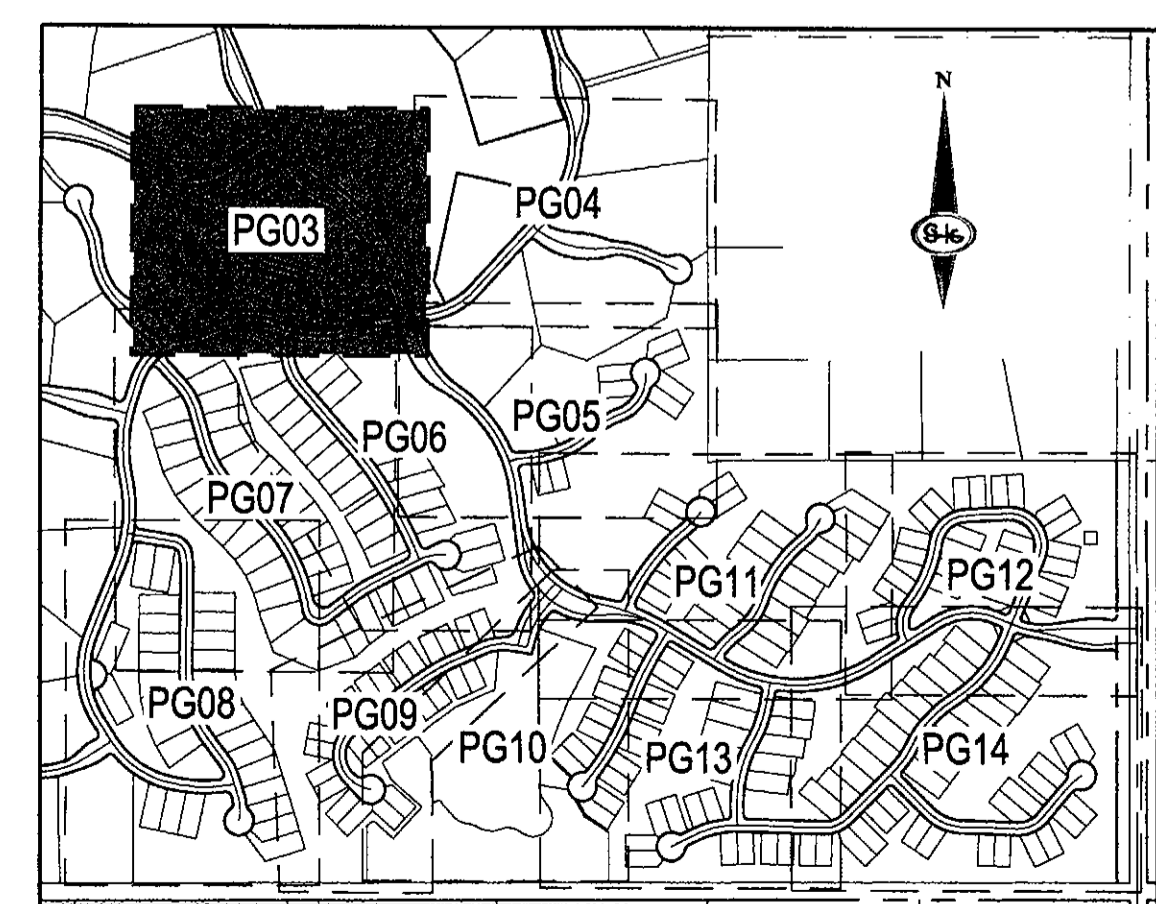
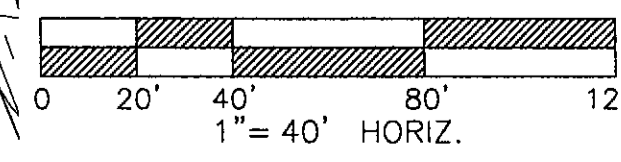

Contact Arizona 911 at least two full working days before you begin excavation.

Call 911 or click Arizona911.com

SLATER HANIFAN GROUP
CONSULTING ENGINEERS & PLANNERS
11201 N. TATUM BOULEVARD #250, PHOENIX, AZ 85028
PHONE (602) 987-8664

NO.	DESCRIPTION	DATE	BY	APC DATE

SCOTTSDALE, AZ
TOLL BROTHERS LAND DEVELOPMENT
SERENO CANYON PHASE 4
PARCEL A PRELIMINARY GRADING PLAN

DATE: 03/26/2018
 DRAFTER: SB
 DESIGNER: GR/AAL
 CHECKED: LB
 PROJECT NO.
TOL1702-000

PG03
SHEET 3 OF 15

A:\1702-000\scott\sereno\parcels\preliminary\grading\plan\1702-000_pre_grad_03.dwg 5/7/2018 9:49 AM Ben Rivers

1-ZN-2005 #2 16-ZN-2011 51-DR-2017 16-PP-2017

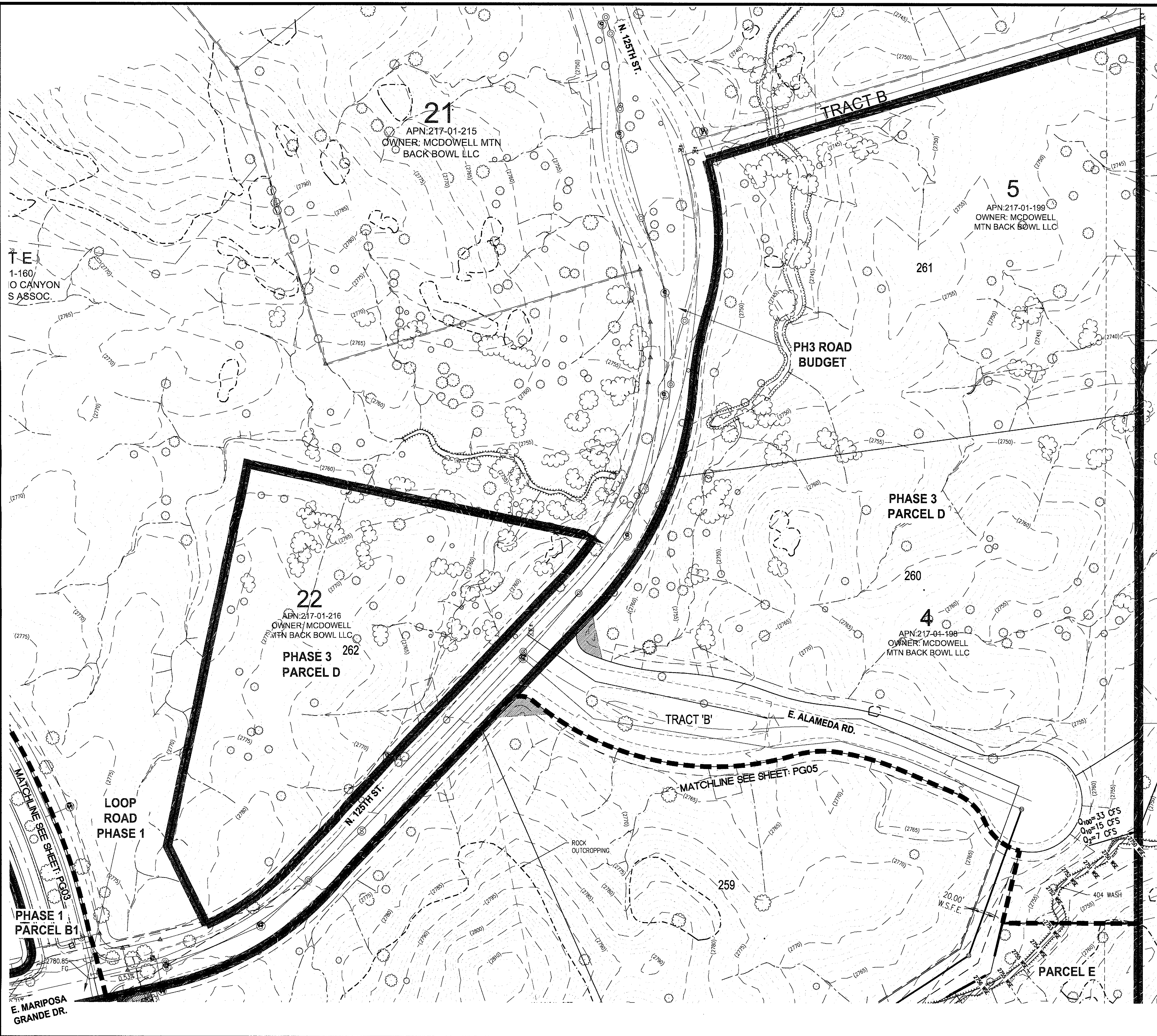

1-160
O CANYON
S ASSOC.

21
APN: 217-01-215
OWNER: MCDOWELL MTN
BACK BOWL LLC

5
APN: 217-01-199
OWNER: MCDOWELL
MTN BACK BOWL LLC

22
APN: 217-01-216
OWNER: MCDOWELL
MTN BACK BOWL LLC
262
PHASE 3
PARCEL D

**PHASE 3
PARCEL D**

4
APN: 217-04-198
OWNER: MCDOWELL
MTN BACK BOWL LLC

260

**LOOP ROAD
PHASE 1**

**PHASE 1
PARCEL B1**

**E. MARIPOSA
GRANDE DR.**

**PH3 ROAD
BUDGET**

E. ALAMEDA RD.

N. 125TH ST.

MATCHLINE SEE SHEET: PG05

**ROCK
OUTCROPPING**

**Q100=33 CFS
Q10=15 CFS
Q2=7 CFS**

**20.00'
W.S.F.E.**

404 WASH

PARCEL E

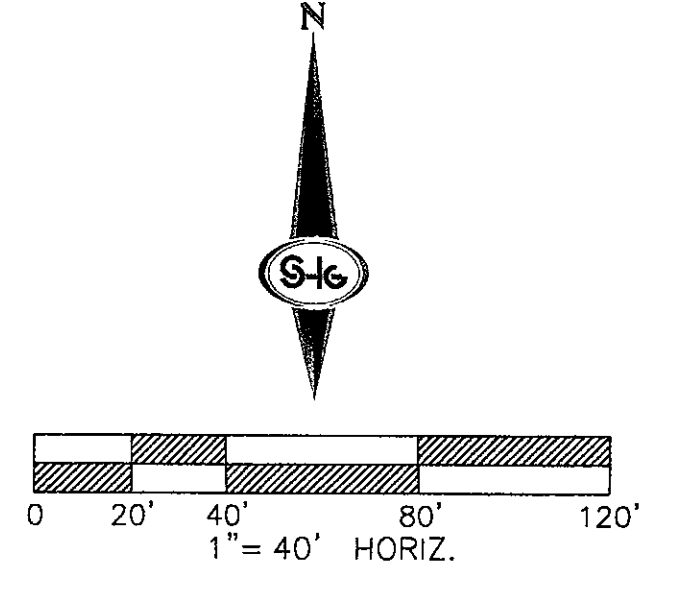

**PRE POST
Q100= 49 33
Q10= 22 15
Q2= 9 7**

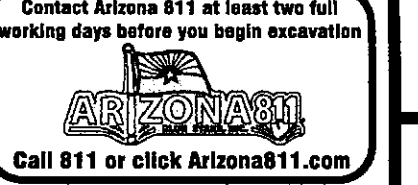
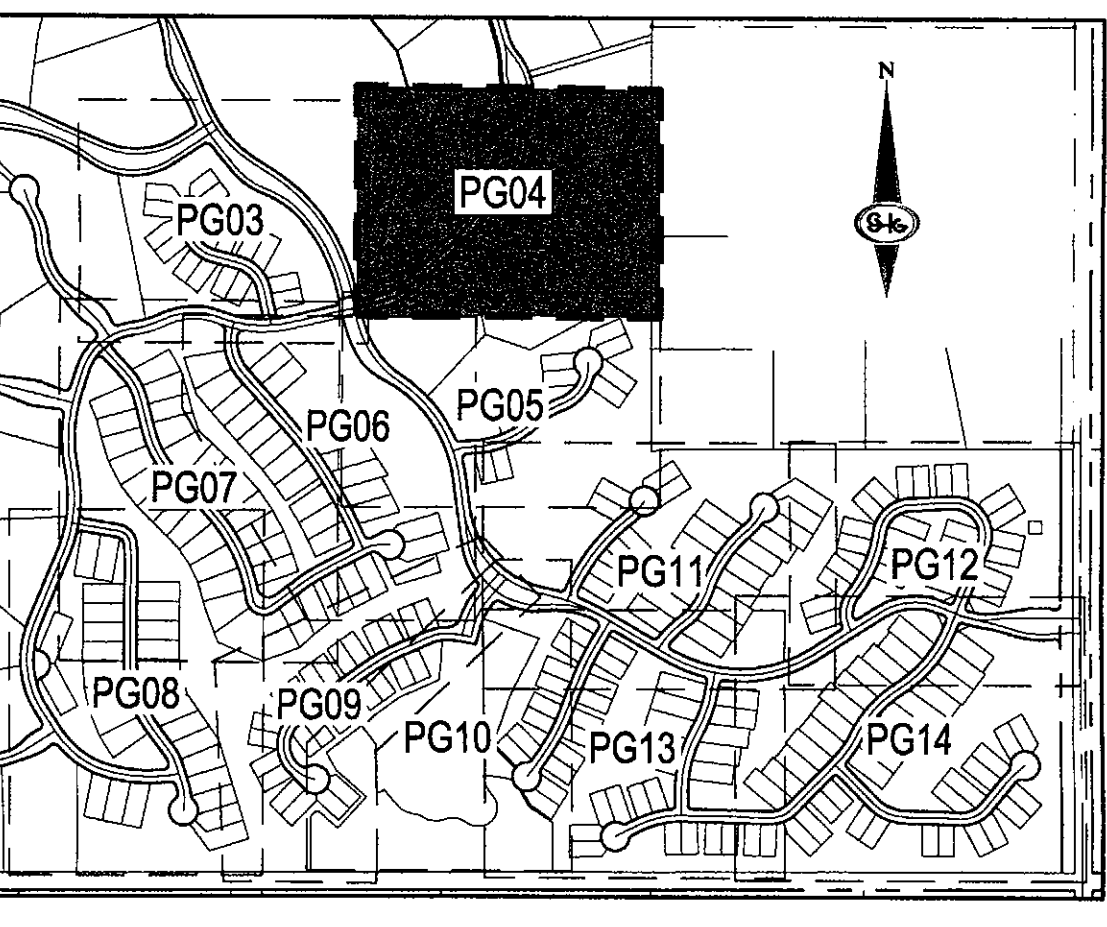

**SLATER
HANIFAN
GROUP**
CONSULTING ENGINEERS & PLANNERS
11201 N. TATUM BOULEVARD #250, PHOENIX, AZ 85028
PHONE (602) 687-9664

NO.	DESCRIPTION	DATE	BY	APC	DATE

SCOTTSDALE, AZ
TOLL BROTHERS LAND DEVELOPMENT
SERENO CANYON PHASE 4
PARCEL E NORTH PRELIMINARY GRADING PLAN

**11
4 N
5 E**
DATE: 03/26/2018
DRAFTER: SB
DESIGNER: GR/AAL
CHECKED: LB
PROJECT NO.
TOL1702-000

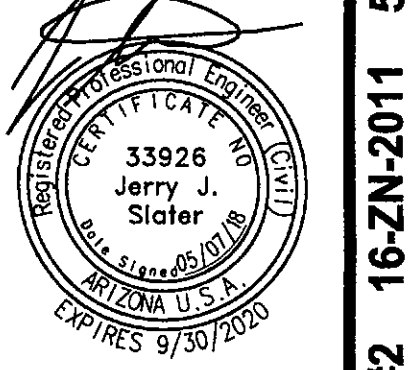

PG04
SHEET 4 OF 15

1-ZN-2005 #2 16-ZN-2011 51-DR-2017 16-PP-2017

I:\1702-000_serenocanyon\phase 4\land\utilities\terminology\grading\plan\1702-000_pre-grd-04.dwg 5/7/2018 9:49 AM Bert Rivers

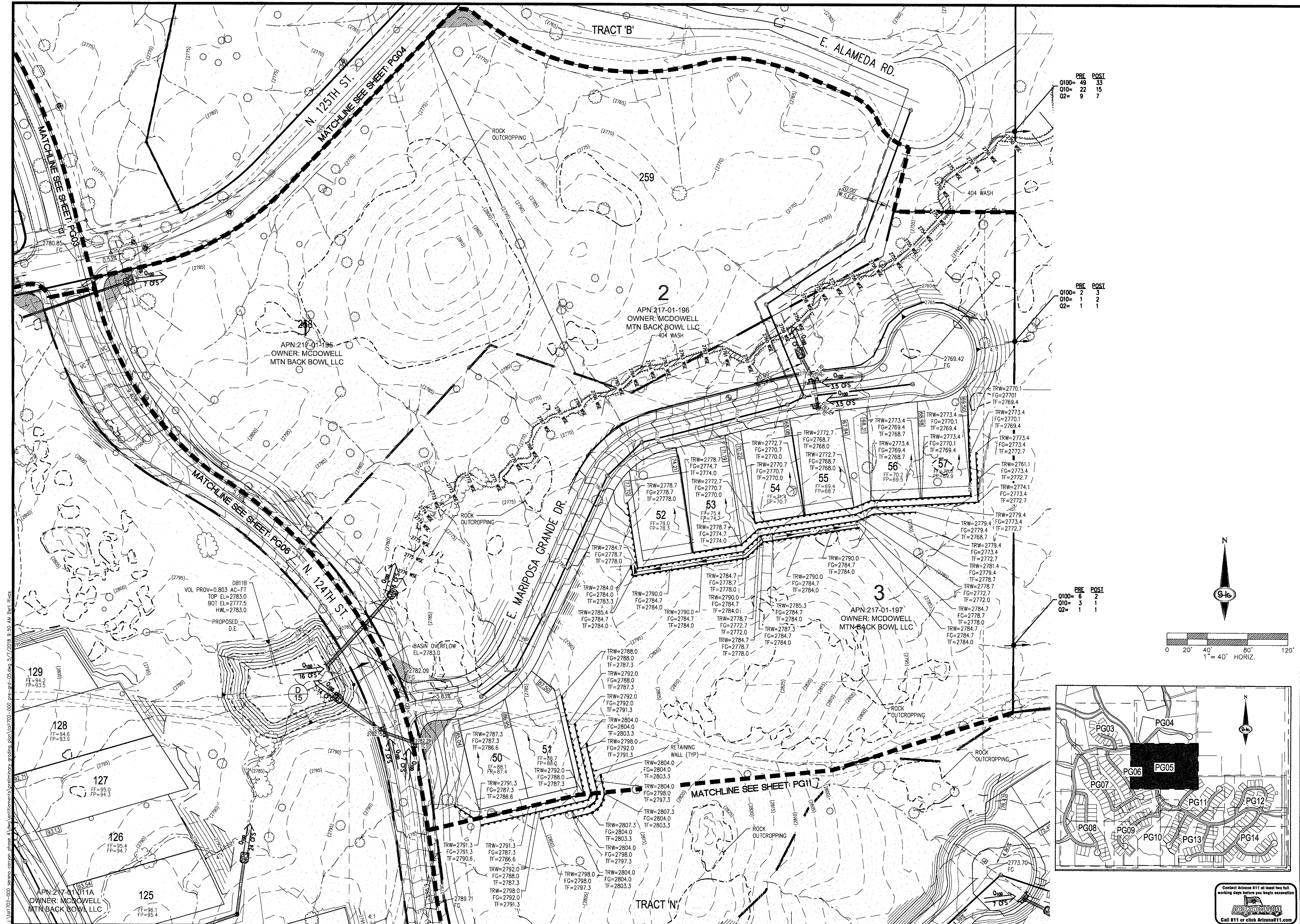

	PRE	POST
0100=	49	33
010=	22	15
02=	9	7

	PRE	POST
0100=	2	3
010=	1	2
02=	1	1

	PRE	POST
0100=	6	2
010=	3	1
02=	1	1

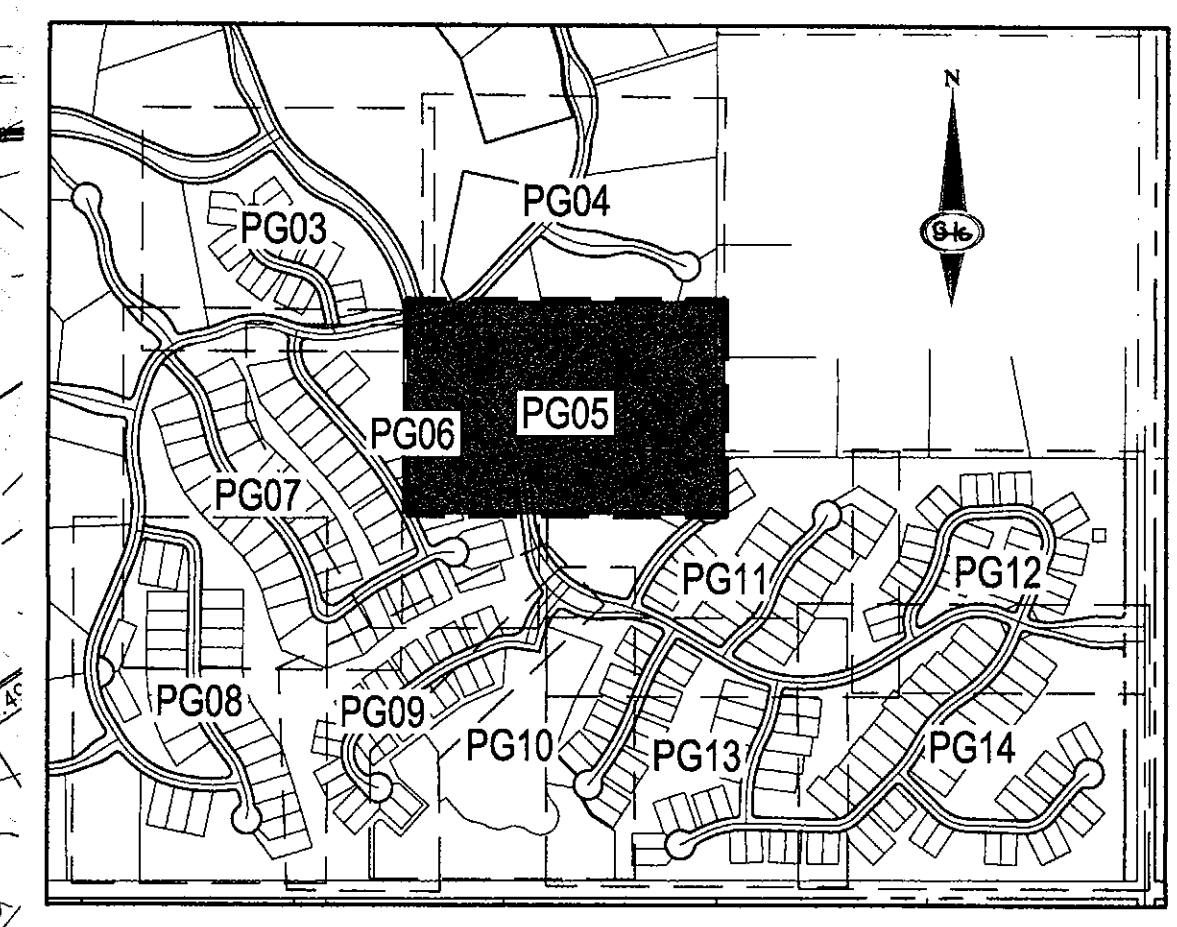
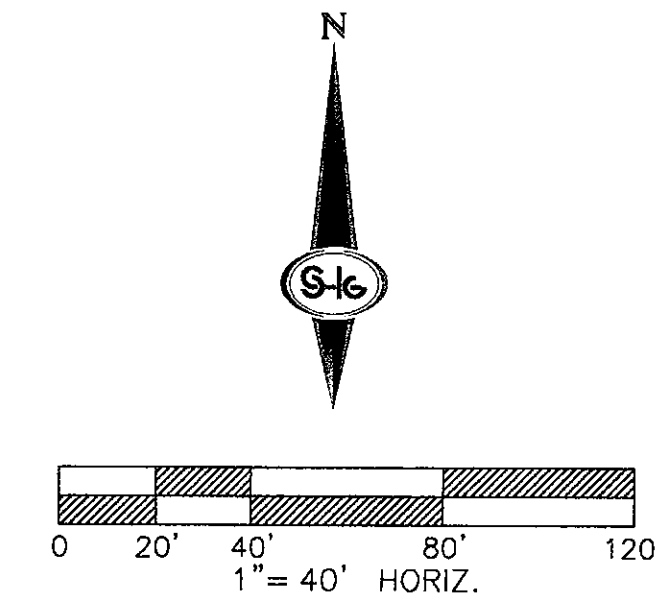

Contact Arizona 911 at least two full working days before you begin excavation

Call 911 or click Arizona911.com

SLATER HANIFAN GROUP
CONSULTING ENGINEERS & PLANNERS
11201 N. TATUM BOULEVARD #250, PHOENIX, AZ 85028
PHONE (602) 687-9864

DATE	BY	APP.	DATE	DESCRIPTION

SECTION 11
RANGE 9 E
TOLL BROTHERS LAND DEVELOPMENT

SCOTTSDALE, AZ

SERENO CANYON PHASE 4
PARCEL E SOUTH PRELIMINARY GRADING PLAN

DATE:	03/26/2018
DRAFTER:	SB
DESIGNER:	GR/AAL
CHECKED:	LB
PROJECT NO.	TOL1702-000

PG05
SHEET 5 OF 15

1:ZLN-2005-000 sereno canyon phase 4 (sheet) (plan) (top) (000) pre-rcd-05.dwg 5/7/2018 9:50 AM Bert Rios



DATE	BY	APC

DESCRIPTION	NO.

SCOTTSDALE, AZ

TOLL BROTHERS LAND DEVELOPMENT

SERENO CANYON PHASE 4

PARCEL B1 PRELIMINARY GRADING PLAN

DATE:	03/26/2018
DRAFTER:	SB
DESIGNER:	GR/AAL
CHECKED:	LB
PROJECT NO.:	TOL1702-000

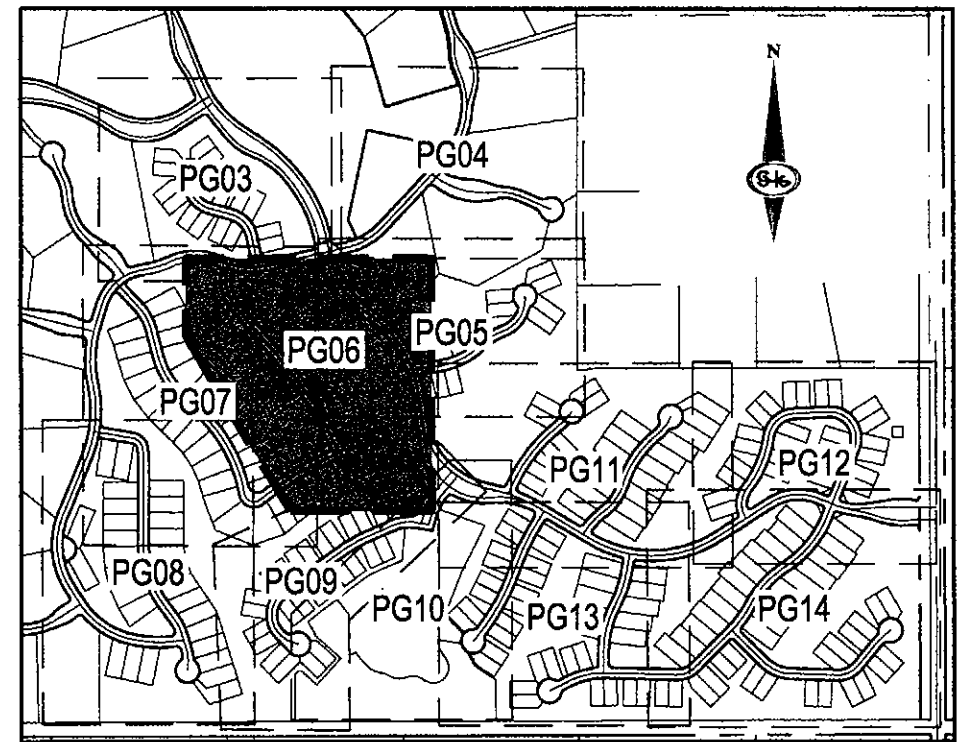
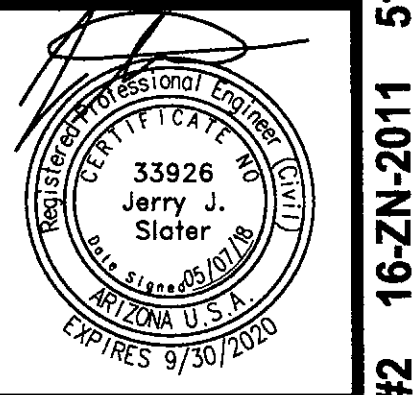

Contact Arizona 811 at least two full working days before you begin excavation

ARIZONA 811

Call 811 or click Arizona811.com

I:\1702-000 sereno canyon phase 4\new\utilities\civil\grading\plan\1702-000_pre-act-06.dwg 5/7/2018 9:50 AM Bert. Ross

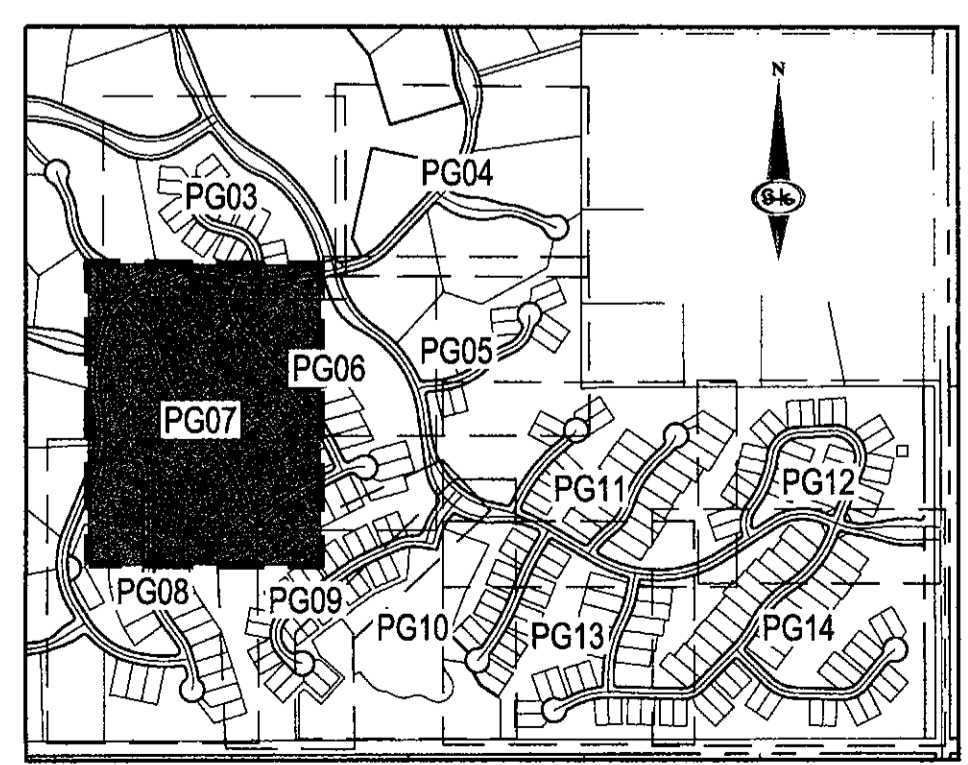

Contact Arizona 811 at least two full working days before you begin excavation.
ARIZONA 811
 Call 811 or click Arizona811.com

SLATER HANIFAN GROUP
 CONSULTING ENGINEERS & PLANNERS
 11201 N. TATUM BOULEVARD #250, PHOENIX, AZ 85028
 PHONE (602) 687-9864

DATE	BY	APR	DATE	DESCRIPTION

SCOTTSDALE, AZ

TOLL BROTHERS LAND DEVELOPMENT
SERENO CANYON PHASE 4
PARCEL B2 PRELIMINARY GRADING PLAN

DATE:	03/26/2018
DRAFTER:	SB
DESIGNER:	GR/AAL
CHECKED:	LB
PROJECT NO.:	TOL1702-000
PG07 SHEET 7 OF 15	

I:\1702-000 sereno canyon phase 4\work\utilities\preliminary grading plan\1702-000 pre-spc-07.dwg, 5/7/2018 9:51 AM Ben Rivers

DATE	BY	APC	DATE	DESCRIPTION

NO.	SCOTTSDALE, AZ

TOLL BROTHERS LAND DEVELOPMENT
SERENO CANYON PHASE 4
PARCEL D PRELIMINARY GRADING PLAN

SECTION 11
TOWNSHIP 4 N
RANGE 11 E

DATE: 03/26/2018
DRAFTER: SB
DESIGNER: GR/AAL
CHECKED: LB
PROJECT NO.
TOL1702-000

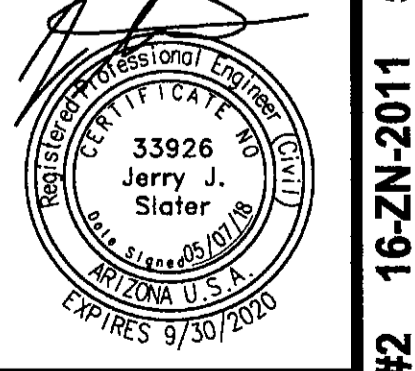

PG08
SHEET 8 OF 15

Contact Arizona 811 at least two full working days before you begin excavation
ARIZONA
Call 811 or click Arizona811.com

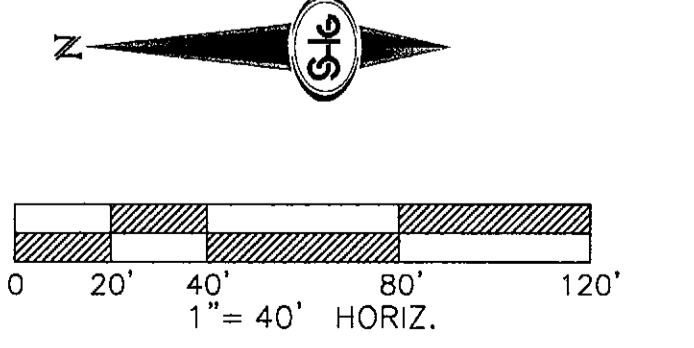
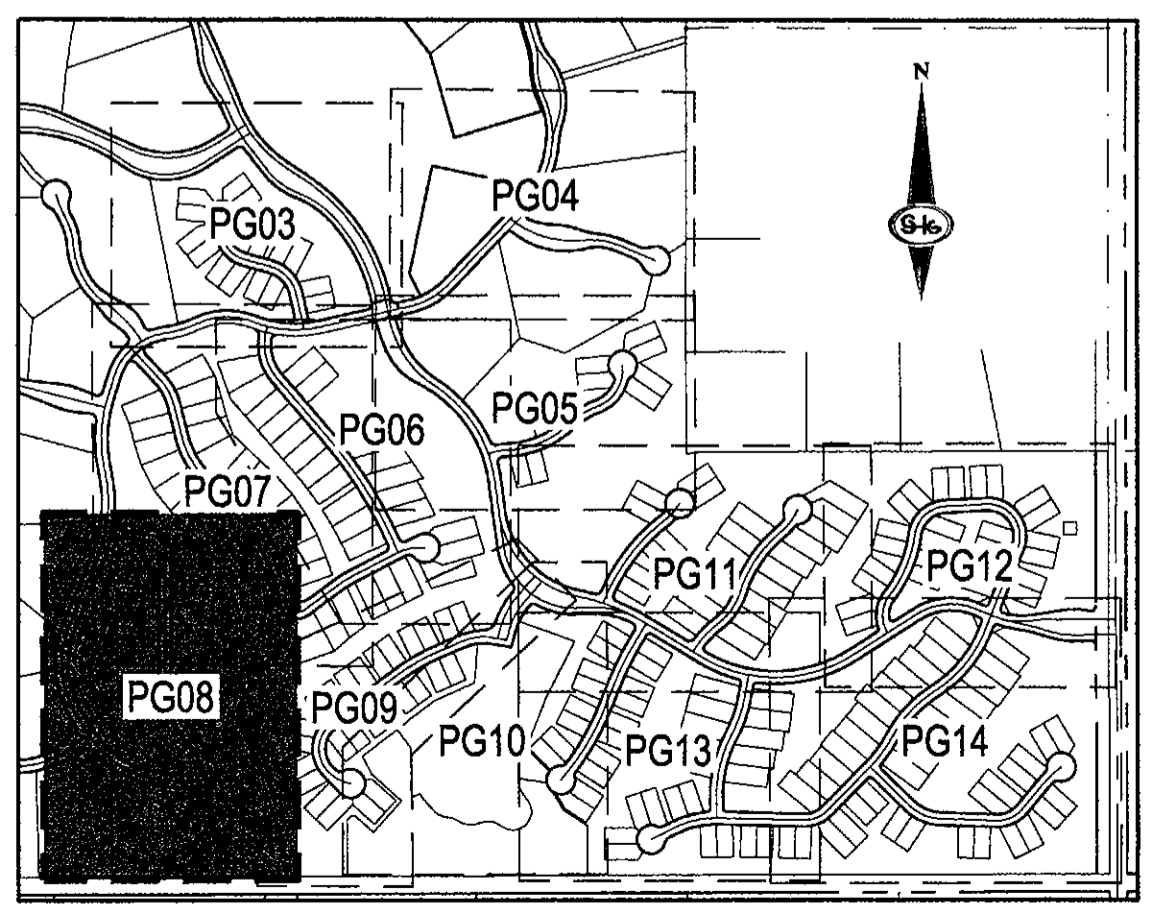
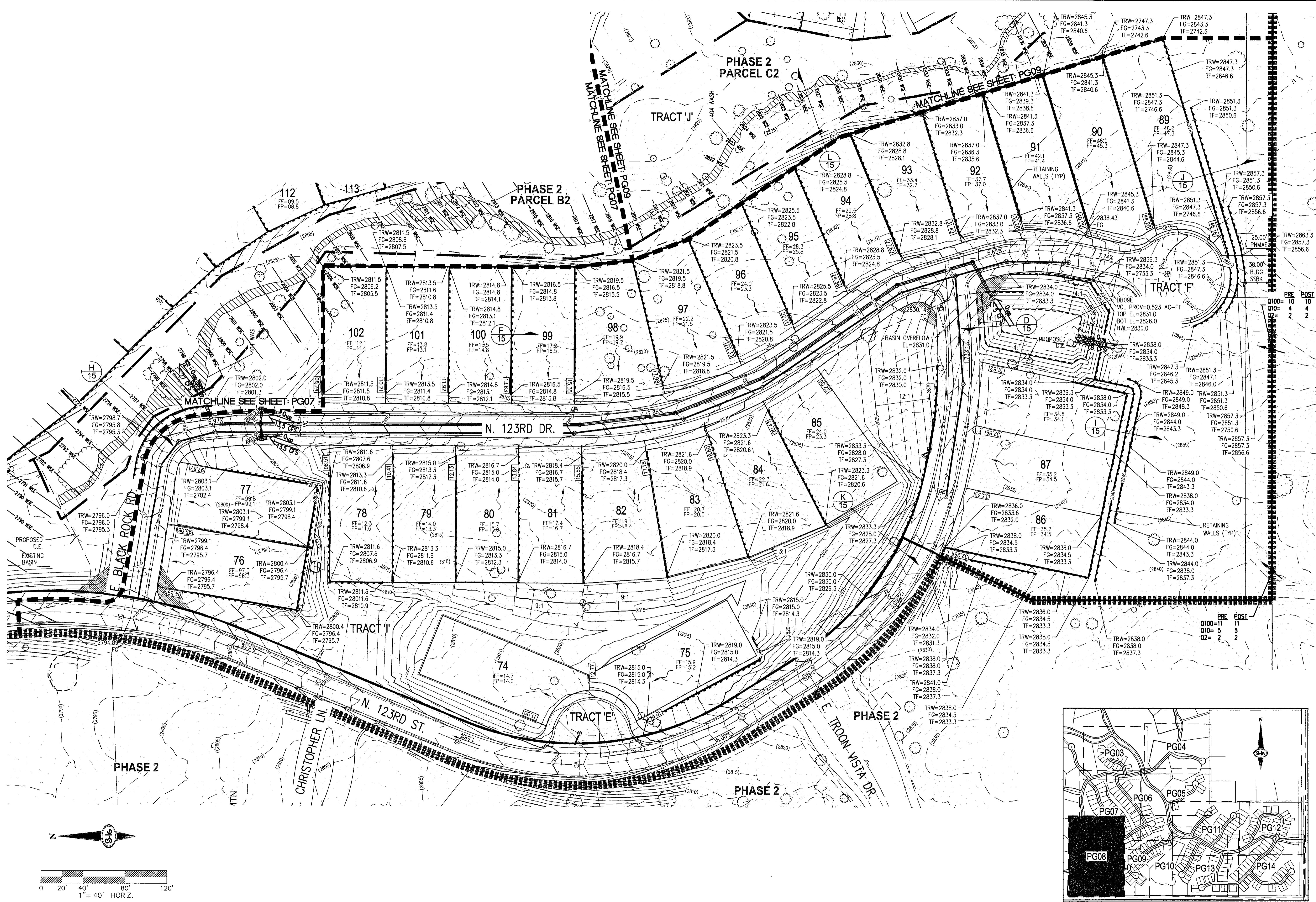

\\l01702-000-arizona\arcadocs\canyon_phase_4\canyon\entitlements\preliminary_grading_plan\l01702-000_pre-ent-08.dwg 5/7/2018 9:51 AM Del Rio

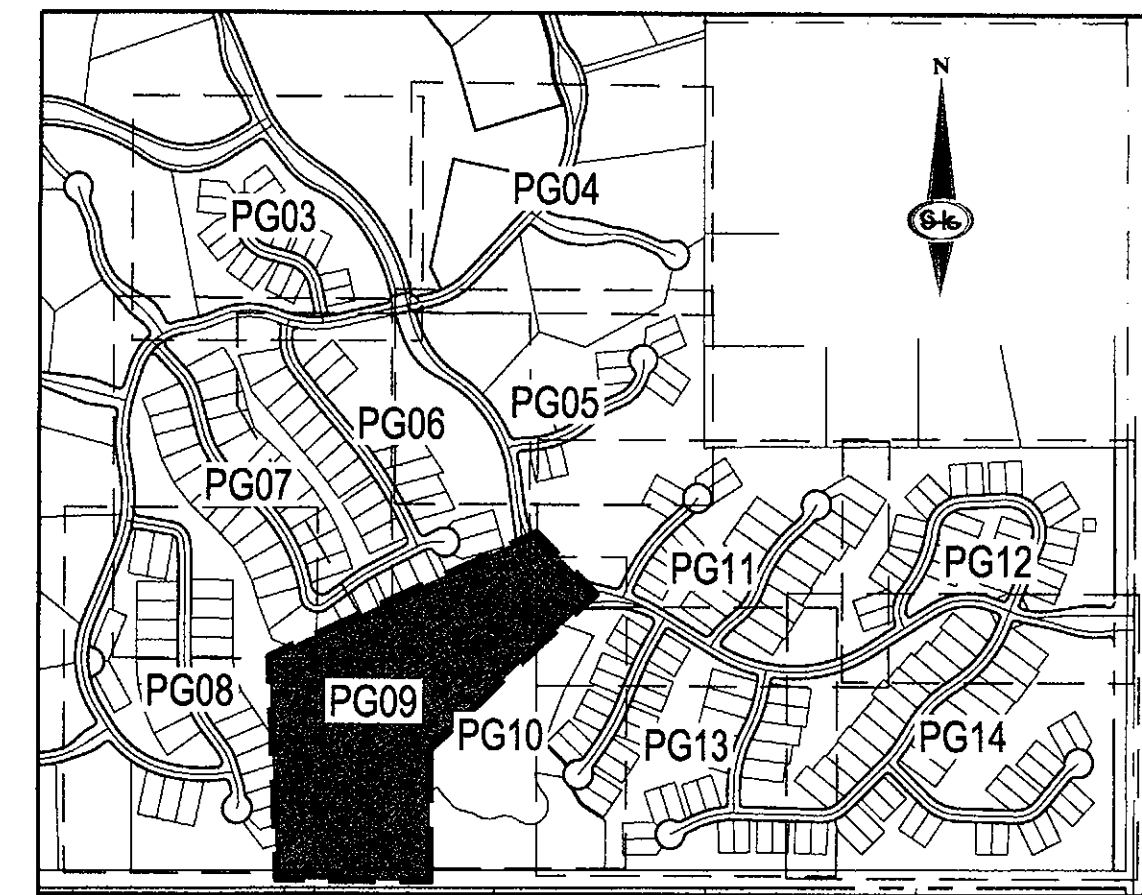

DATE	BY	APC	DATE	APC

SECTION 11
 TOWNSHIP 4 N
 RANGE 9 E
 SCOTTSDALE, AZ

TOLL BROTHERS LAND DEVELOPMENT

SERENO CANYON PHASE 4

PARCEL C1 & C2 PRELIMINARY GRADING PLAN

DATE: 03/26/2018
 DRAFTER: SB
 DESIGNER: GR/AAL
 CHECKER: LB

PROJECT NO.
TOL1702-000

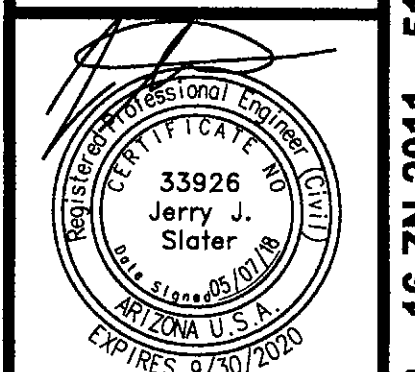

PG09
 SHEET 9 OF 15

Contact Arizona 911 at least two full working days before you begin excavation.
ARIZONA
 Call 911 or click Arizona911.com

A:\1702-000_sereno_canyon_phase_4\user\jerry.slater\preliminary_grading\plots\1702-000_pre-grd-09.dwg 5/7/2018 9:53 AM Ben Rivers

1-ZN-2005 #2 16-ZN-2011 16-ZN-2011 51-DR-2017 16-PP-2017

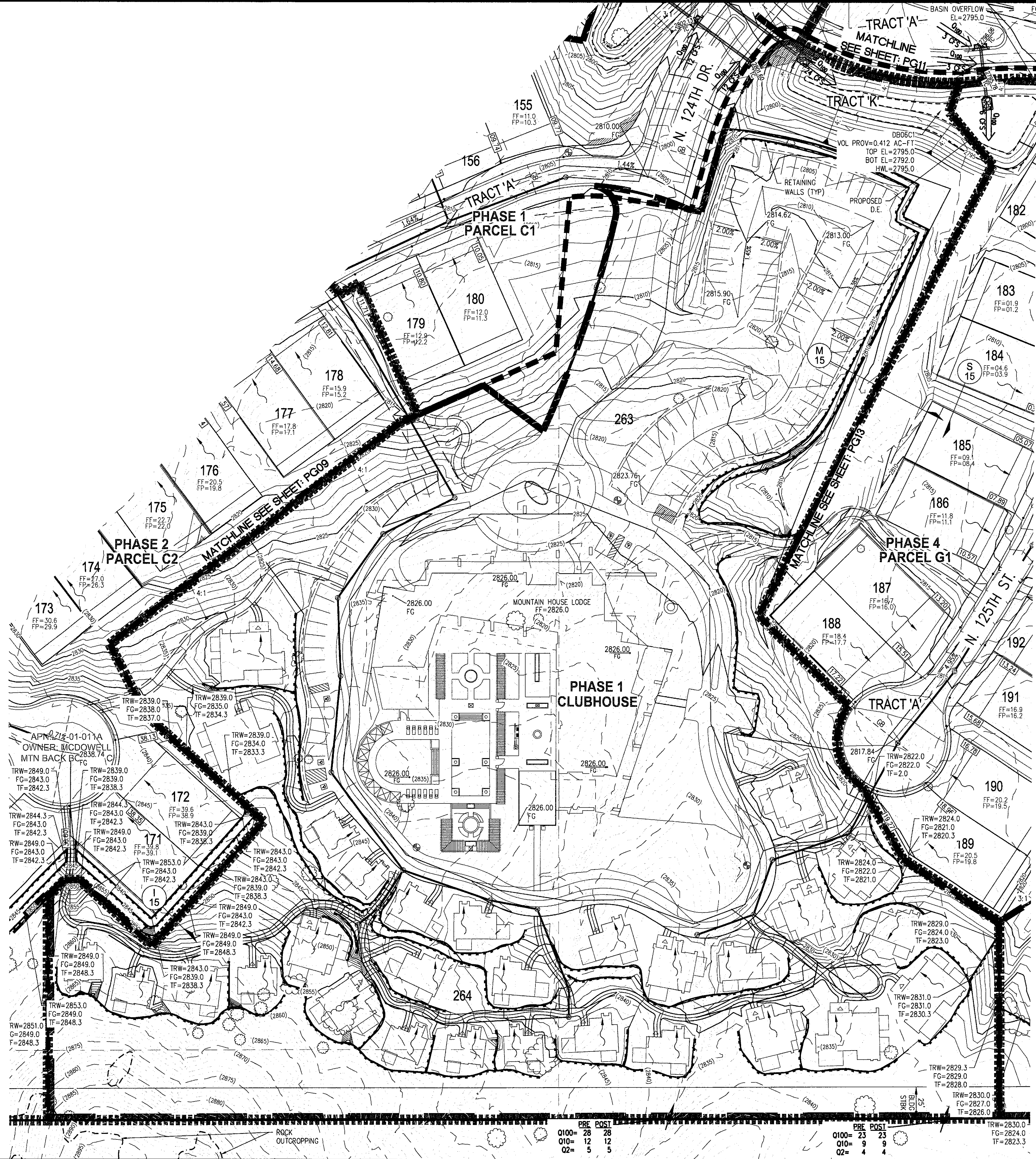
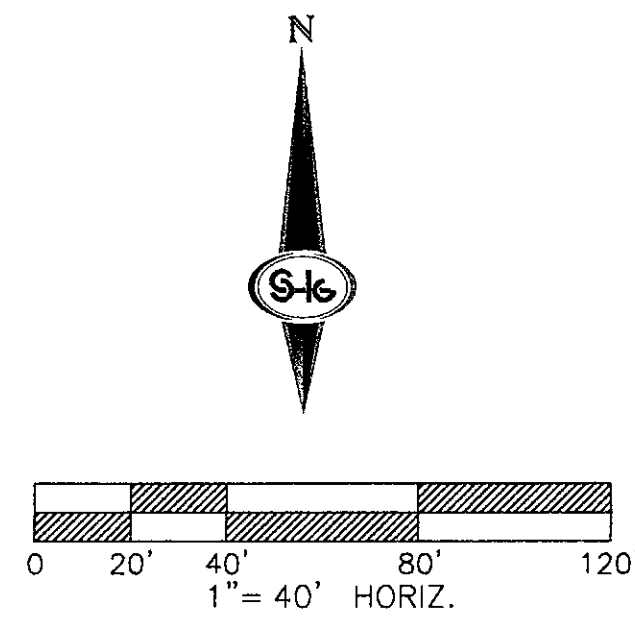
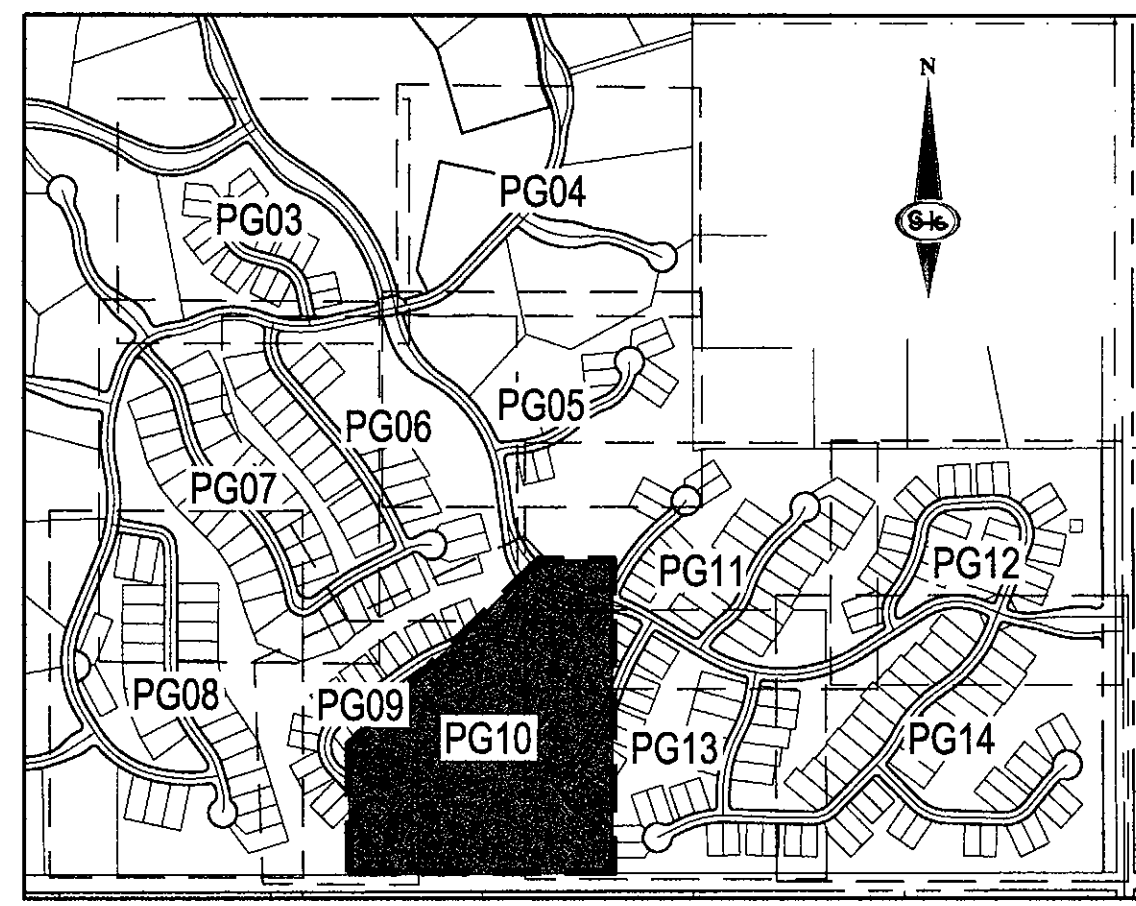

A:\1702-000_serenocanyon\phases\A\plan\settlements\preliminary\grading\plan\1702-000_pre-imp-10.dwg, \$/7/2018 9:52 AM Bart Rivers

SLATER HANIFAN GROUP
ENGINEERS & PLANNERS
 11201 N. TATUM BOULEVARD #250, PHOENIX, AZ 85028
 PHONE (602) 687-9664

DATE	BY	APC	DATE	APC

NO.	DESCRIPTION

SECTION 11
 TOWNSHIP 4 N
 RANGE 5 E
 SCOTTSDALE, AZ
TOLL BROTHERS LAND DEVELOPMENT
SERENO CANYON PHASE 4
CLUBHOUSE PRELIMINARY GRADING PLAN

DATE: 03/26/2018
 DRAFTER: SB
 DESIGNER: GR/AAL
 CHECKED: LB
 PROJECT NO.
TOL1702-000

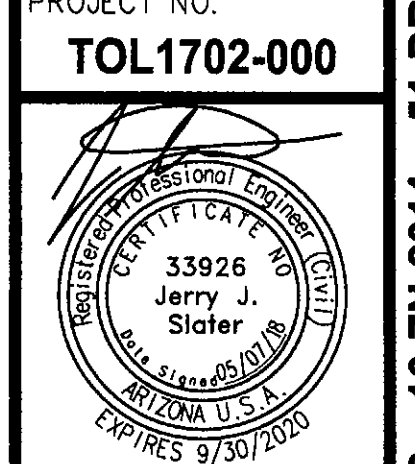

PG10
 SHEET 10 OF 15

Contact Arizona 811 at least two full working days before you begin excavation.

 Call 811 or click Arizona811.com

PRE	POST	PRE	POST
0100= 28	28	0100= 23	23
010= 12	12	010= 9	9
02= 5	5	02= 4	4

1-ZN-2005 #2 16-ZN-2011 51-DR-2017 16-PP-2017

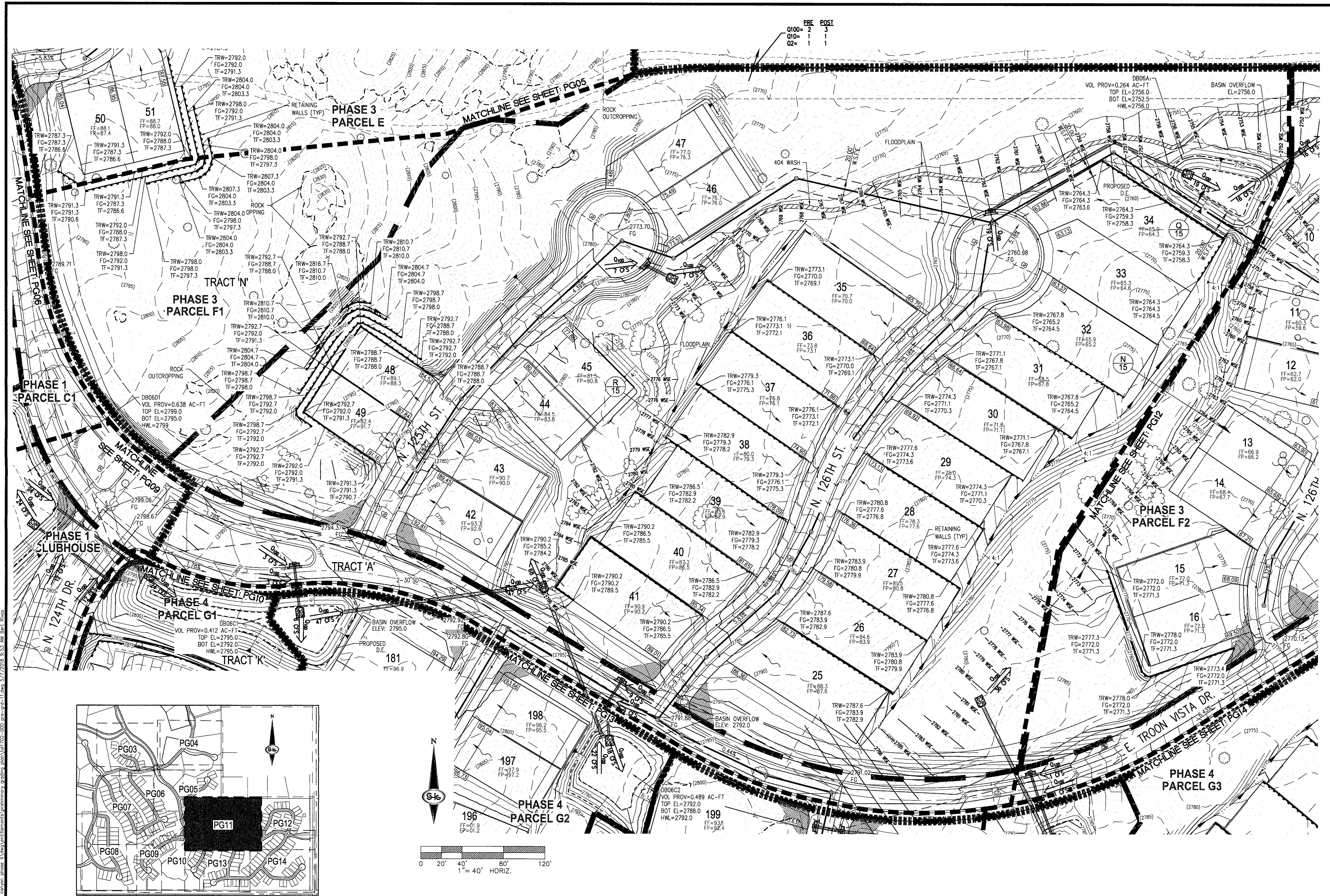

PRE	POST
Q100= 2	3
Q10= 1	1
Q2= 1	1

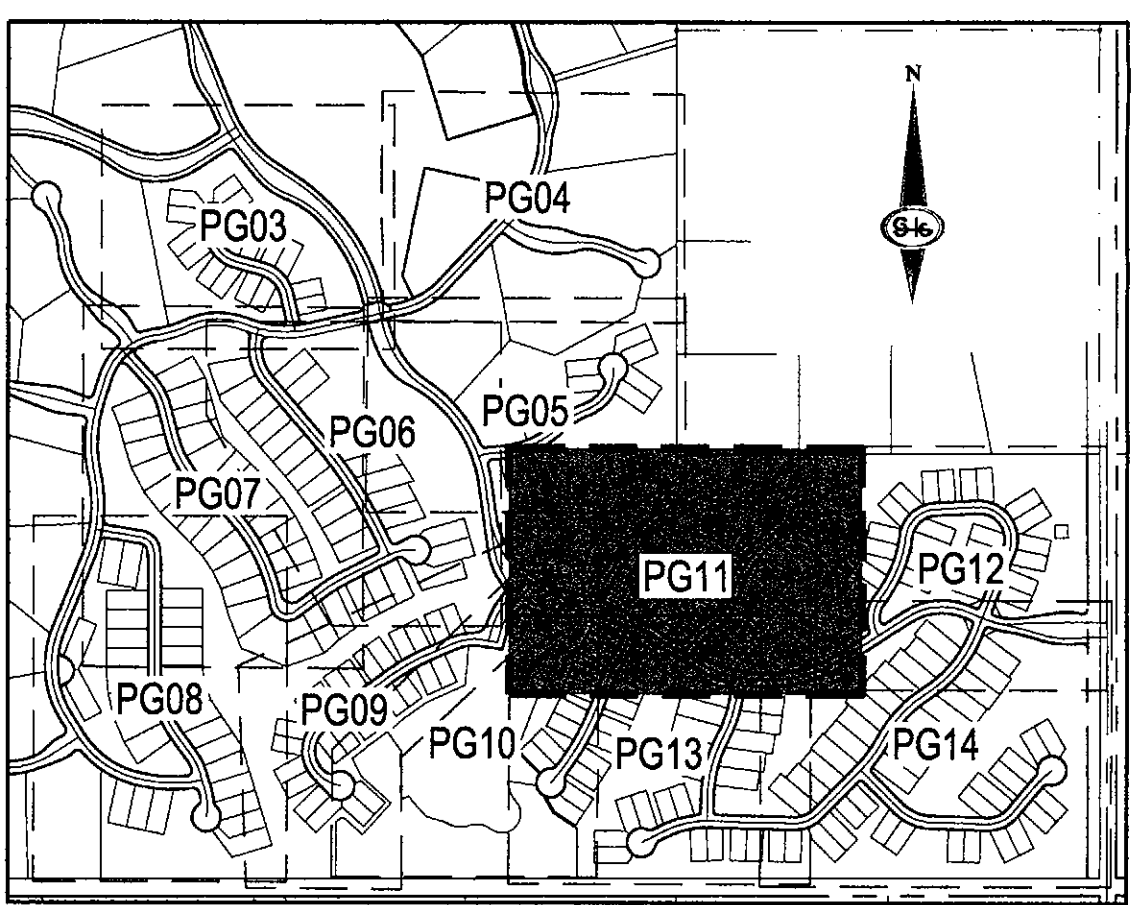

SLATER HANIFAN GROUP
 CONSULTING ENGINEERS & PLANNERS
 11201 N. TATUM BOULEVARD #250, PHOENIX, AZ 85028
 PHONE (602) 687-9864

DATE	BY	APPROVED	DESCRIPTION

SCOTTSDALE, AZ

TOLL BROTHERS LAND DEVELOPMENT
SERENO CANYON PHASE 4
PARCEL F1 PRELIMINARY GRADING PLAN

SECTION 11
 TOWNSHIP 4 N
 RANGE 5 E

DATE: 03/26/2018
 DRAFTER: SB
 DESIGNER: GR/AAL
 CHECKED: LB

PROJECT NO.
TOL1702-000

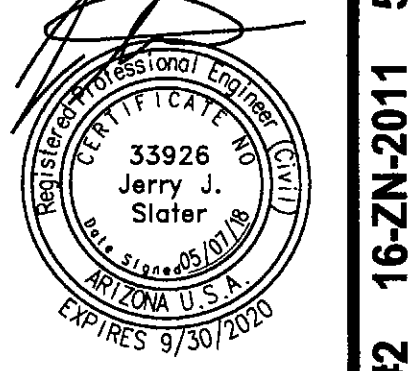

PG11
 SHEET 11 OF 15

Contact Arizona 911 at least two full working days before you begin excavation
ARIZONA
 Call 811 or click Arizona11.com

I:\1702-000-sereno-canyon-phase-4\plan\civil\1702-000-pre-rcd-11.dwg, 5/7/2018 9:53 AM, Ben Rivers

1-ZN-2005 #2 16-ZN-2011 51-DR-2017 16-PP-2017

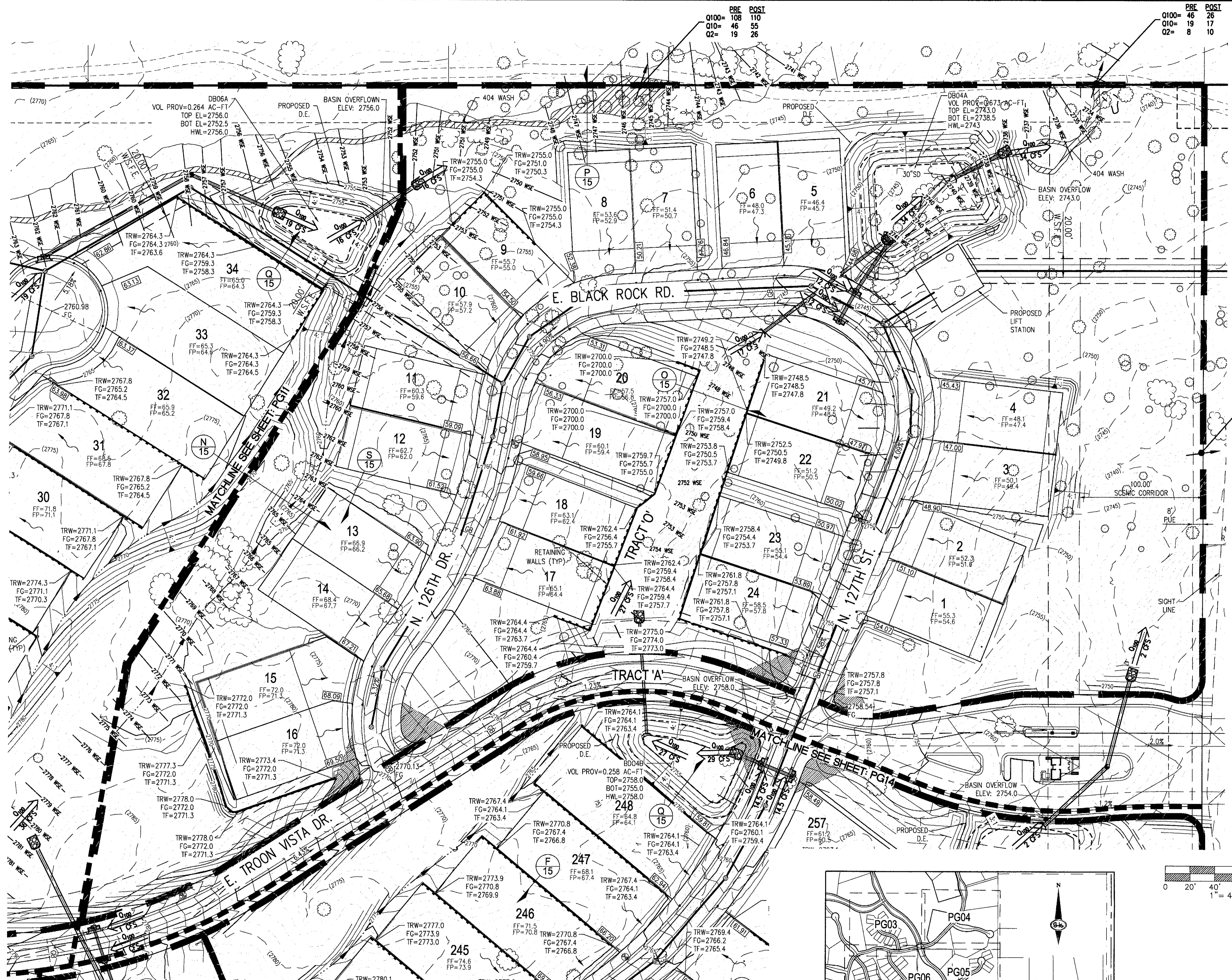

PRE POSI
Q100= 108 110
Q10= 46 55
Q2= 19 26

PRE POSI
Q100= 46 26
Q10= 19 17
Q2= 8 10

Q100= 14 7
Q10= 6 3
Q2= 3 1

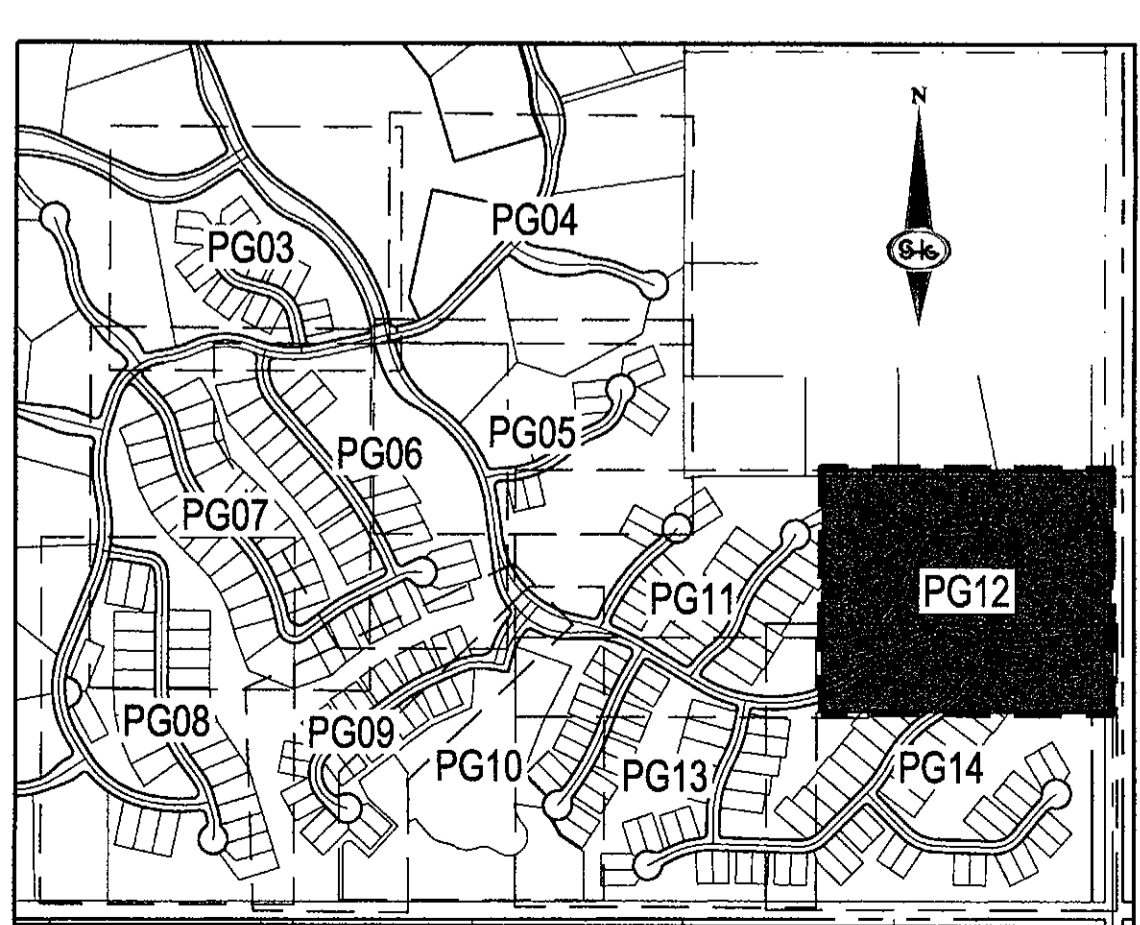

SLATER HANIFAN GROUP
CONSULTING ENGINEERS & PLANNERS
11201 N. TATUM BOULEVARD #200, PHOENIX, AZ 85028
PHONE (602) 887-9864

NO.	DESCRIPTION	DATE	BY	APC

SCOTTSDALE, AZ

TOLL BROTHERS LAND DEVELOPMENT
SERENO CANYON PHASE 4
PARCEL F2 PRELIMINARY GRADING PLAN

SECTION 11
TOWNSHIP 4 N
RANGE 5 E

DATE: 03/26/2018
DRAFTER: SB
DESIGNER: GR/AAL
CHECKED: LB

PROJECT NO.
TOL1702-000

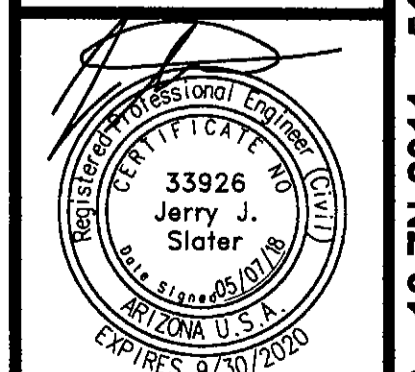

PG12
SHEET 12 OF 15



I:\1702-000 sereno canyon phase 4\dwg\ventilations\preliminary grading plan\1702-000 pre-gd-12.dwg 5/7/2018 9:53 AM Bert Bivas

1-ZN-2005 #2 16-ZN-2011 51-DR-2017 16-PP-2017

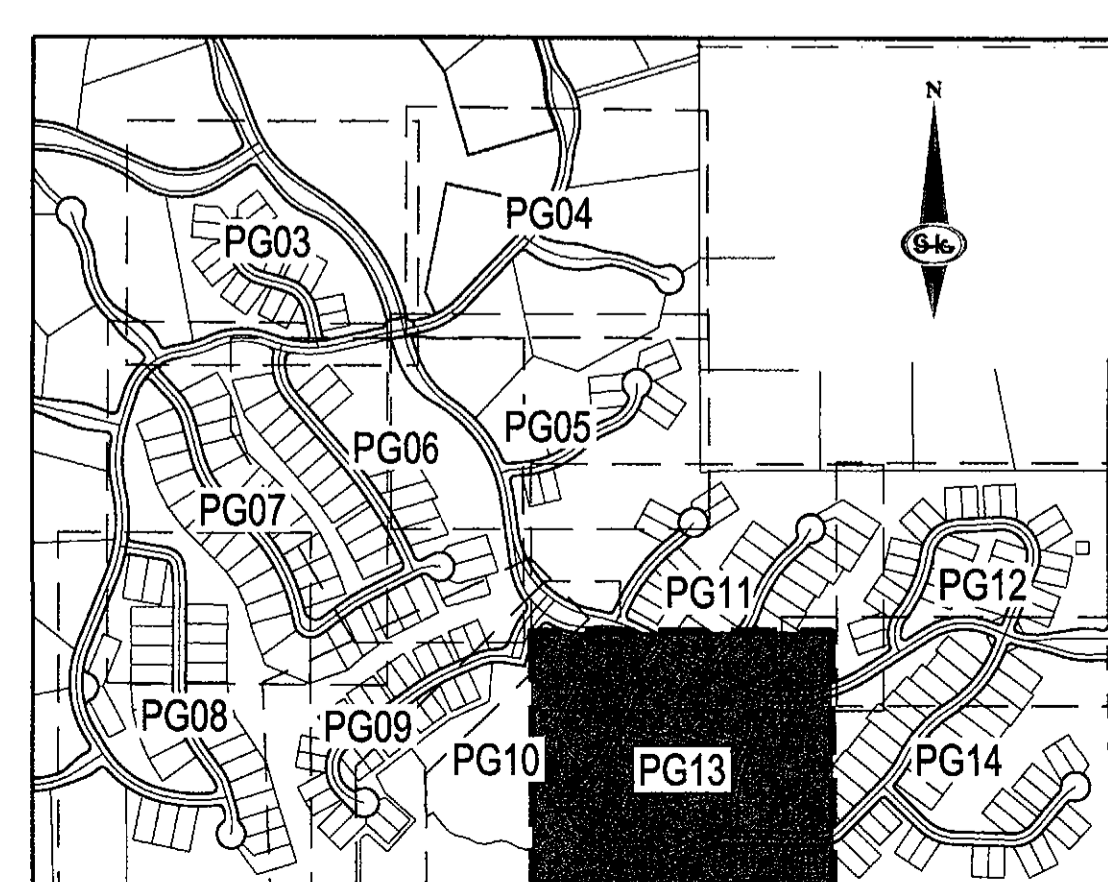
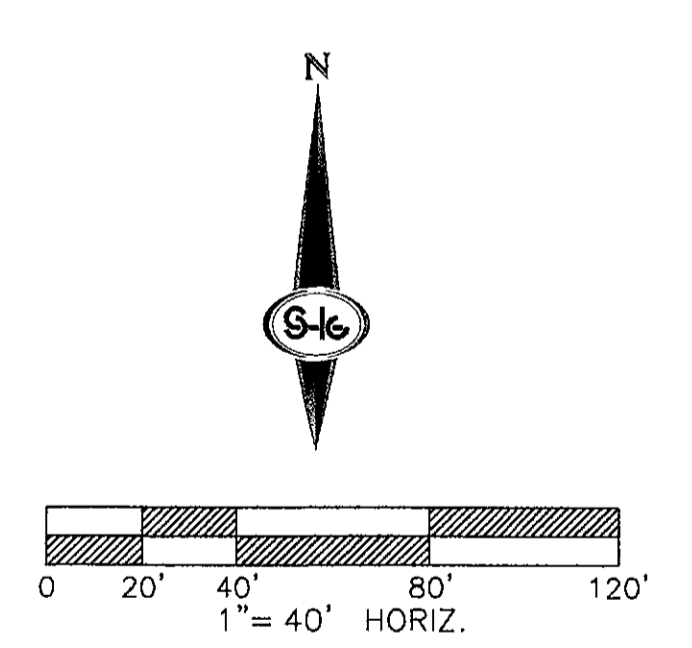
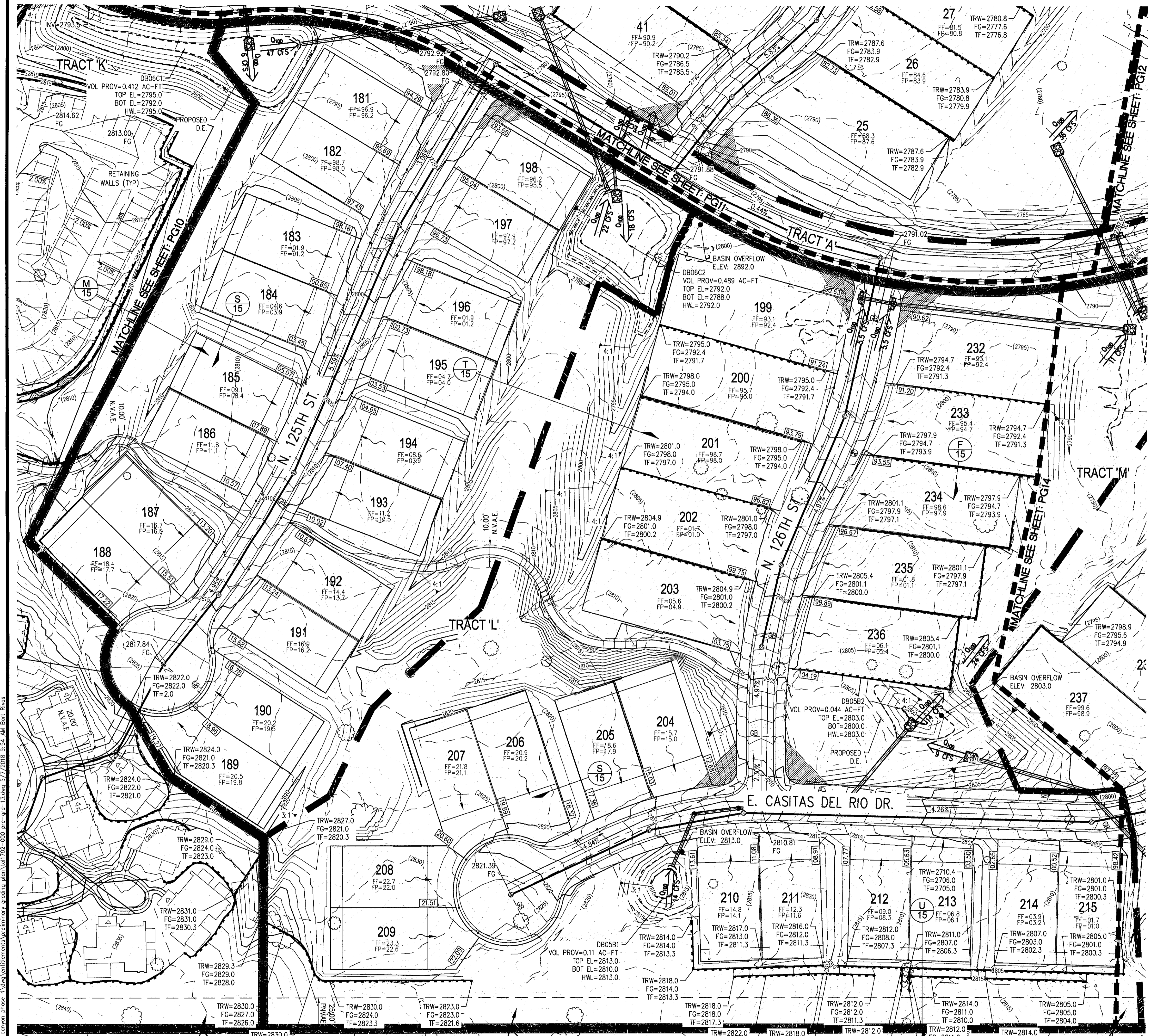

	PRE	POST
0100=	17	17
010=	7	7
010=	9	9
02=	4	4

	PRE	POST
0100=	17	17
010=	7	7
02=	3	3

	PRE	POST
0100=	20	20
010=	8	8
02=	3	3

NO.	DESCRIPTION	DATE	BY	APP.

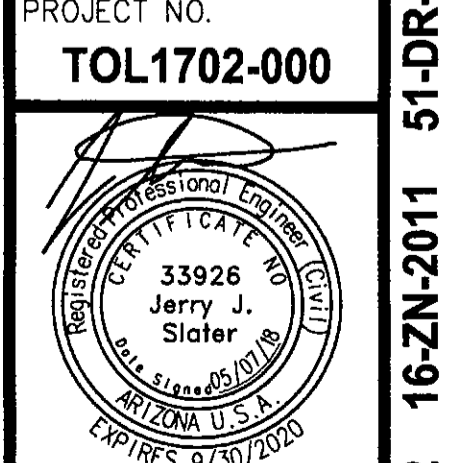

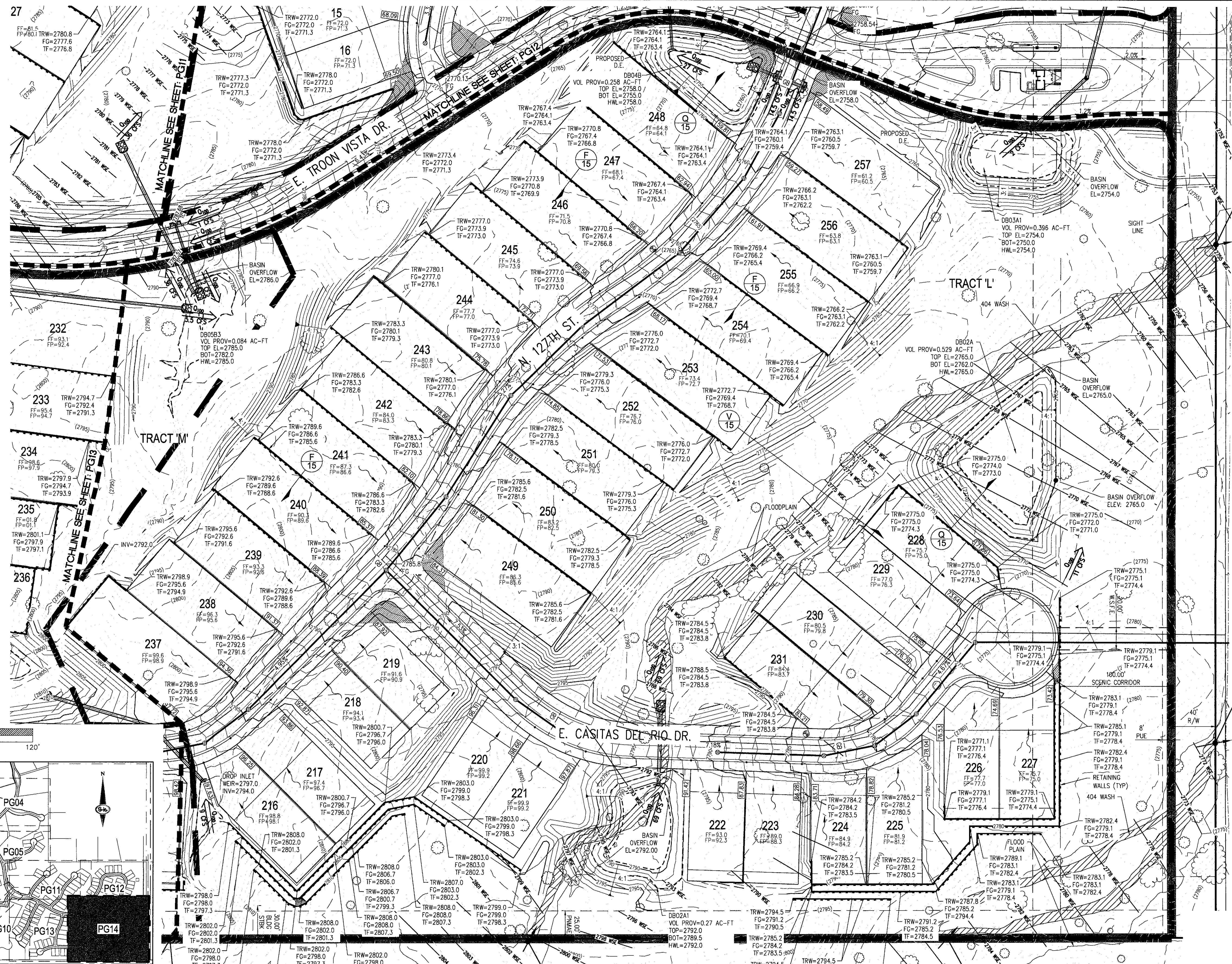

PRE	POST
0100= 75	73
010= 31	29
02= 13	12

PRE	POST
0100= 201	201
010= 82	82
02= 42	42

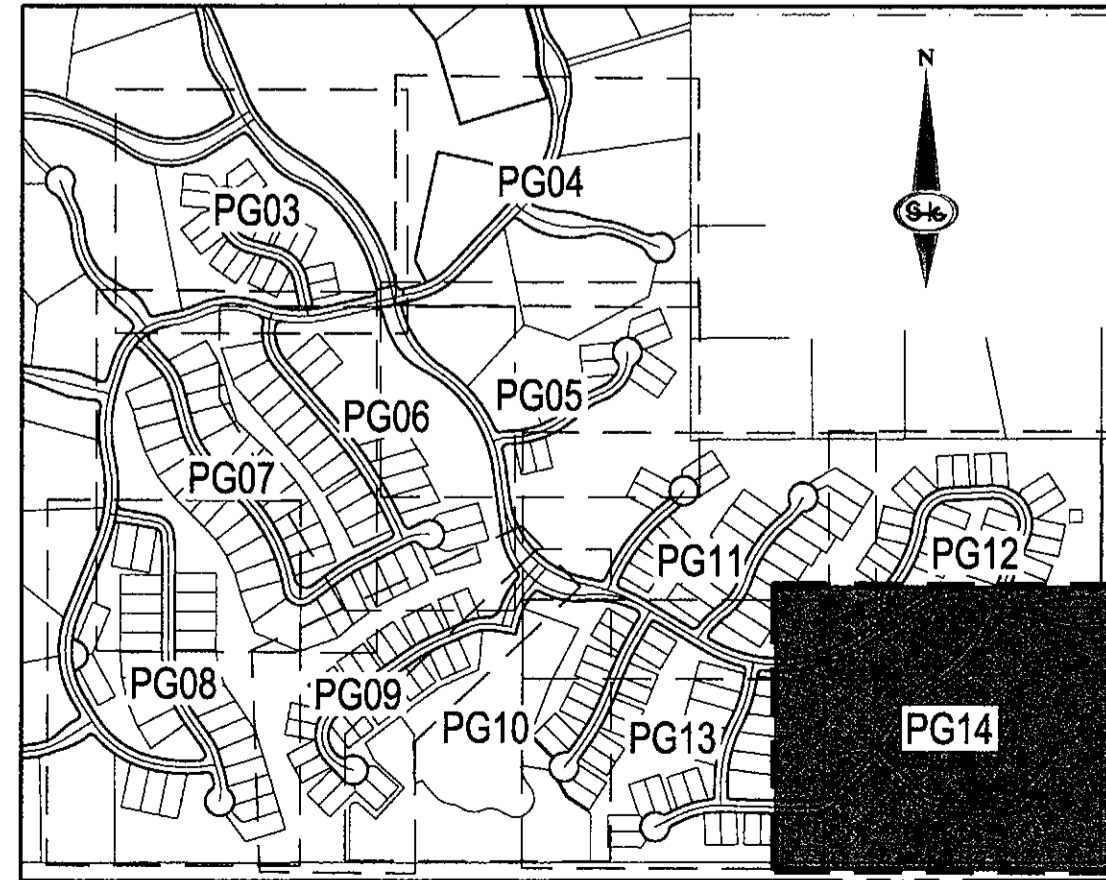
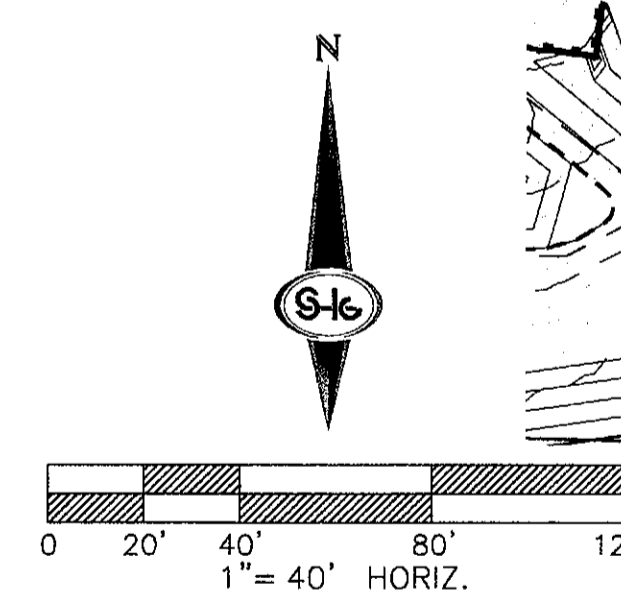

PRE	POST
0100= 20	8
010= 8	8
02= 3	3

PRE	POST
0100= 75	75
010= 31	31
02= 13	13

PRE	POST
0100= 201	201
010= 82	82
02= 42	42

Contact Arizona 811 at least two full working days before you begin excavation.

 Call 811 or click Arizona811.com

SLATER HANIFAN GROUP
CONSULTING ENGINEERS & PLANNERS
 11201 N. TATUM BOULEVARD #250, PHOENIX, AZ 85028
 PHONE (602) 987-9664

DATE	BY	DESCRIPTION

SCOTTSDALE, AZ
 SECTION 11
 TOWNSHIP 4 N
 RANGE 5 E

TOLL BROTHERS LAND DEVELOPMENT
SERENO CANYON PHASE 4
PARCEL G3 PRELIMINARY GRADING PLAN

DATE:	03/26/2018
DRAFTER:	SB
DESIGNER:	GR/AAL
CHECKED:	LB
PROJECT NO.	TOL1702-000

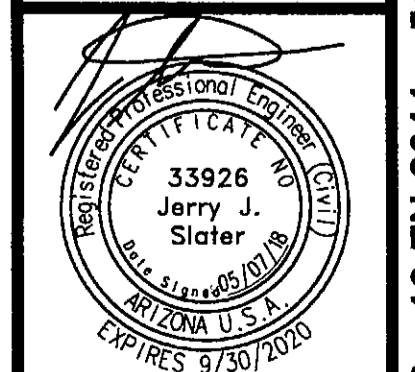

1-ZN-2005 #2 16-ZN-2011 51-DR-2017 16-PP-2017

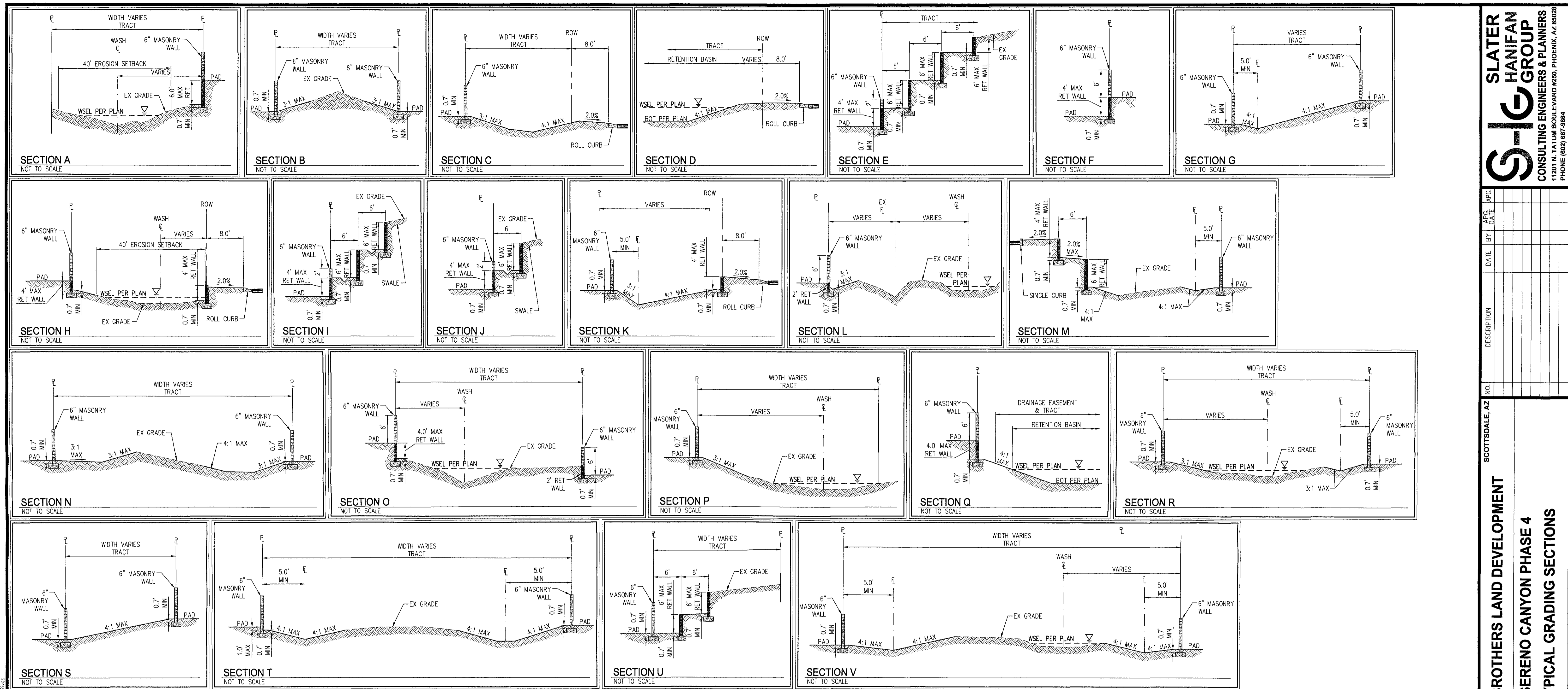

NO.	DESCRIPTION	DATE	BY	APR. DATE	APC

SCOTTSDALE, AZ

TOLL BROTHERS LAND DEVELOPMENT
SERENO CANYON PHASE 4
TYPICAL GRADING SECTIONS

SECTION 11
 TOWNSHIP 4 N
 RANGE 9 E

DATE: 03/26/2018
 DRAFTER: SB
 DESIGNER: GR/AAL
 CHECKED: LB

PROJECT NO.
TOL1702-000

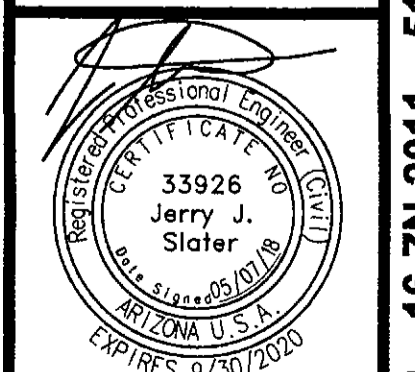

PG15
 SHEET 15 OF 15

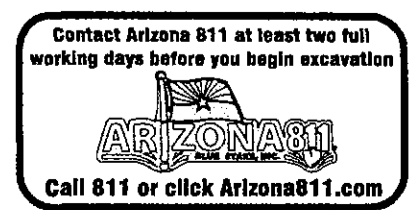

I:\1702-000_sereno_canyon_phase_4\Drawings\1702-000_gradings\1702-000_gradings.dwg 5/7/2018 9:54 AM Bert Brios