

**Drainage Reports**

**Abbreviated Water & Sewer Need Reports**

**Water Study**

**Wastewater Study**

**Stormwater Waiver Application**

City of Scottsdale  
Attention: Stormwater Management Division  
7447 E Indian School Rd  
Scottsdale, AZ 85251

March 20, 2018

**RE: Drainage Memo for Scottsdale Fashion Square Lux Wing- PAD D and E**

To whom it may concern:

**Introduction**

The improvements for Scottsdale Fashion Square Lux Wing- PAD D and E include the development of approximately 13,395 SF of gross floor area commercial building space with associated site improvements. The development of PAD D and E is a part of the larger Scottsdale Fashion Square Lux Wing Entry project, known to the City of Scottsdale as 26-DR-2017. Scottsdale Fashion Square Lux Wing- PAD D and E is located west of Goldwater Boulevard, north of the existing Scottsdale shopping center, east of the existing Dillard's, and south of the entry drive off Goldwater Boulevard that provides ingress/egress into the mall purple parking garage.

This document is to be used in place of a Final Drainage Report and in conjunction with the Master Drainage Report for Scottsdale Fashion Square Lux Wing, titled, *Final Drainage Report Scottsdale Fashion Square Luxury Wing Entry Site*, dated August 21, 2017 (**Appendix B**), which takes into account the complete buildout of the Lux Wing Entry, including PAD D and E, as shown in Figure 2 and Figure 4 of *Final Drainage Report Scottsdale Fashion Square Luxury Wing Entry Site*, dated August 21, 2017 (**Appendix B**). The purpose of this drainage statement is to confirm compliance to City of Scottsdale *Design Standards & Policies Manual January 2010*, for Storm Drainage Facilities associated with the Project.

**Description of Existing Drainage Conditions and Characteristics**

The existing site is a fully developed parking lot and landscape area that provides surface parking, ingress/egress to the malls parking structure, and landscape areas which also double as retention basins. Runoff from the limits of construction from PAD

D and E sheet flows in the surface parking lot to an existing onsite private storm system in a new proposed loop parking lot.

No offsite drainage impacts the project limits.

### **Proposed Drainage Conditions**

The proposed drainage will not affect the existing ultimate outfall and will not increase runoff in the existing parking lot gutters or storm system. The west, north and east side of the site will continue to sheet flow in the surface parking lot, routed to the existing onsite private storm system. The south side is connected to the existing mall, and will not create any proposed site drainage.

### **First Flush/ Redevelopment Stormwater Storage Policy**

No additional retention is required for this site because this commercial development has already been taken into account with Scottsdale Fashion Square Lux Wing Entry as outlined in the *Final Drainage Report Scottsdale Fashion Square Luxury Wing Entry Site*, dated August 21, 2017 (**Appendix B**). It should also be noted that this project proposes no removal of retention proposed with Scottsdale Fashion Square Lux Wing Entry, better known as City of Scottsdale project 26-DR-2017. That being said, the "C" coefficient for the site is not being altered because the use and concept will remain the same as originally proposed in the Master Report.

### **Special Conditions**

There are no special conditions for this project.

### **Data Analysis Methods**

No analysis was necessary for this project because the land use and drainage patterns were not altered.

### **Conclusions**

In conclusion, Olsson Associates has confirmed compliance to City of Scottsdale *Design Standards & Policies Manual January 2010* for Storm Drainage Facilities. If you have any further questions, please do not hesitate to contact our office at 602-748-1000.

### **Warning and Disclaimer of Liability**

See attached at the end of the written portion of this statement.

### **References**

City of Scottsdale *Design Standards & Policies Manual January 2010*

*Final Drainage Report Scottsdale Fashion Square Luxury Wing Entry Site*, dated August 21, 2017

Sincerely,



EXPIRES 06/30/20

Andrea Page, P.E.  
Senior Engineer

**Appendices**

Appendix A ..... Scottsdale Fashion Square Lux Wing- PAD D and E  
(applicable sheets only)

Appendix B..... *Final Drainage Report Scottsdale Fashion Square  
Luxury Wing Entry Site, dated August 21, 2017*



# Warning and Disclaimer of Liability

The Drainage and Floodplain Regulations and Ordinances of the City of Scottsdale are intended to "minimize the occurrence of losses, hazards and conditions adversely affecting the public health, safety and general welfare which might result from flooding caused by the surface runoff of rainfall" (Scottsdale Revised Code §37-16).

As defined in S.R.C. §37-17, a flood plain or "Special flood hazard area means an area having flood and/or flood related erosion hazards as shown on a FHBM or FIRM as zone A, AO, A1-30, AE, A99, AH, or E, and those areas identified as such by the floodplain administrator, delineated in accordance with subsection 37-18(b) and adopted by the floodplain board." It is possible that a property could be inundated by greater frequency flood events or by a flood greater in magnitude than a 100-year flood. Additionally, much of the Scottsdale area is a dynamic flood area; that is, the floodplains may shift from one location to another, over time, due to natural processes.

### WARNING AND DISCLAIMER OF LIABILITY PURSUANT TO S.R.C §37-22

"The degree of flood protection provided by the requirements in this article is considered reasonable for regulatory purposes and is based on scientific and engineering considerations. Floods larger than the base flood can and will occur on rare occasions. Floodwater heights may be increased by manmade or natural causes. This article (Chapter 37, Article II) shall not create liability on the part of the city, any officer or employee thereof, or the federal government for any flood damages that result from reliance on this article or any administrative decision lawfully made thereunder."

Compliance with Drainage and Floodplain Regulations and Ordinances does not insure complete protection from flooding. The Floodplain Regulations and Ordinances meet established local and federal standards for floodplain management, but neither this review nor the Regulations and Ordinances take into account such flood related problems as natural erosion, streambed meander or man-made obstructions and diversions, all of which may have an adverse affect in the event of a flood. You are advised to consult your own engineer or other expert regarding these considerations.

I have read and understand the above. If I am an agent for an owner I have made the owner aware of and explained this disclaimer.

\_\_\_\_\_  
Plan Check No.

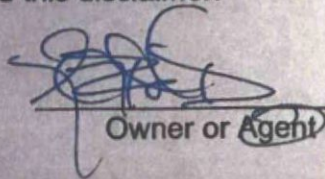
  
\_\_\_\_\_  
Owner or Agent

3/28/17  
\_\_\_\_\_  
Date

## APPENDIX A

# PRELIMINARY SITE PLAN FOR SCOTTSDALE FASHION SQUARE LUXURY WING ENTRY-PAD D AND E SCOTTSDALE, ARIZONA 85251

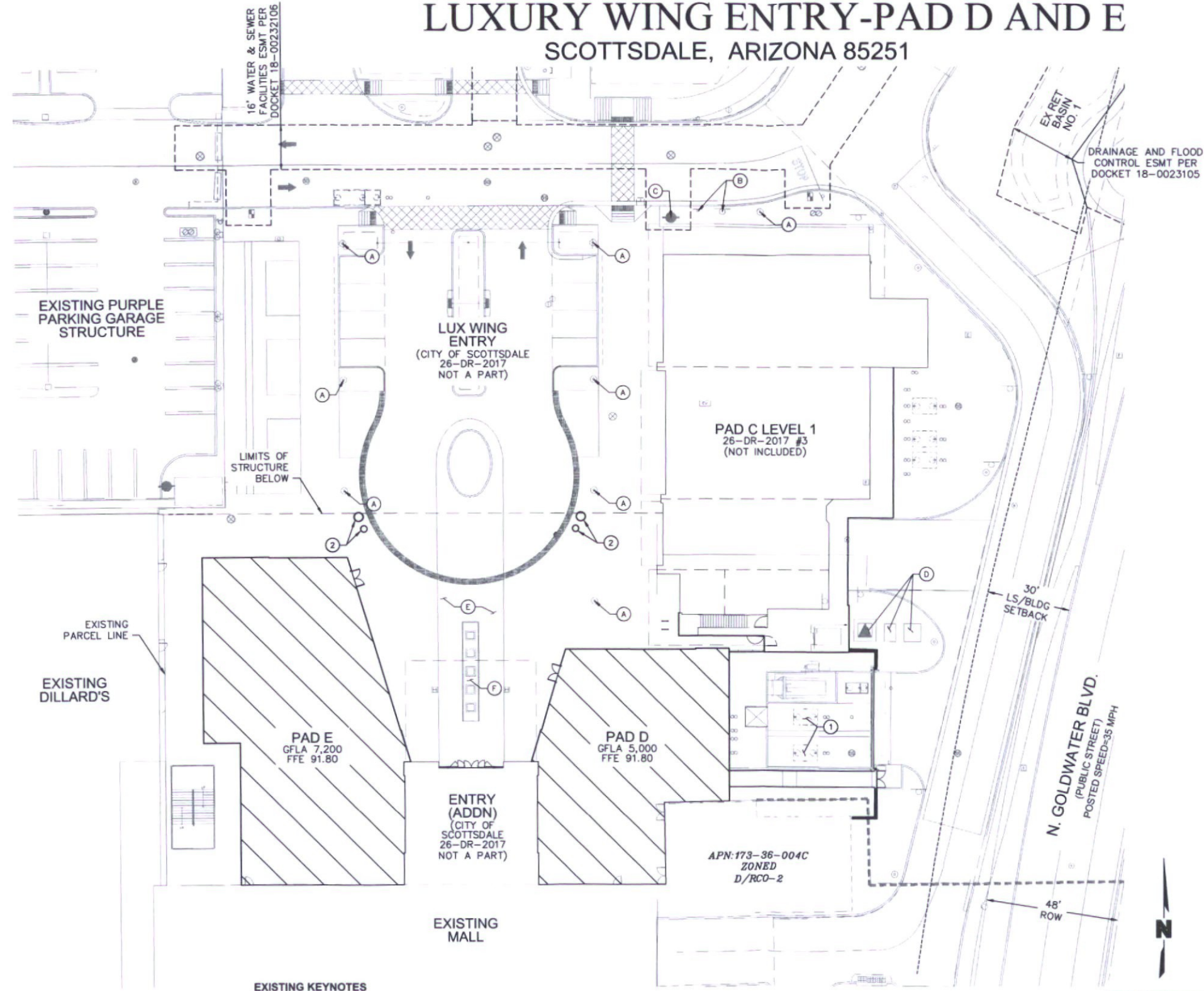

- EXISTING KEYNOTES**
- (A) EXISTING LIGHTING TO REMAIN (BUILT WITH LUX WING).
  - (B) EXISTING SIGN TO REMAIN (BUILT WITH LUX WING).
  - (C) EXISTING HYDRANT TO REMAIN (BUILT WITH LUX WING).
  - (D) EXISTING TRANSFORMER PAD AND SRP ELECTRICAL EQUIPMENT (BUILT WITH LUX WING).
  - (E) EXISTING HARDSCAPE PAVING (BUILT WITH LUX WING LANDSCAPE PLANS).
  - (F) EXISTING WATER FEATURE (BUILT WITH LUX WING LANDSCAPE PLANS).

- SITE PLAN KEYNOTES**
- (1) FUTURE GREASE INTERCEPTOR
  - (2) PROPOSED LANDSCAPE POTS. SEE LANDSCAPE PLANS FOR DETAILS

- SITE PLAN NOTES:**
1. SITE PLAN IS INTENDED TO BE USED FOR PLANNING PURPOSES ONLY AND IS NOT TO BE USED FOR CONSTRUCTION PURPOSES.
  2. SEE LANDSCAPE PLANS FOR REMOVAL/SALVAGE SPECIFICATIONS OF TREES AND VEGETATION.
  3. SEE CONSTRUCTION PLANS FOR CIVIL SPECIFICATIONS. ALL CURB DIMENSIONS ARE TO FACE OF CURB UNLESS OTHERWISE NOTED.

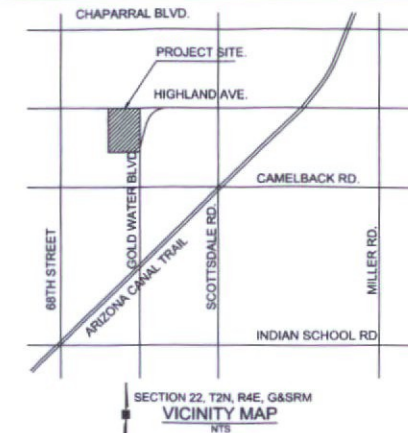
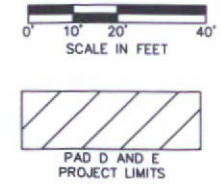

**OWNER/DEVELOPER**  
MACERICH  
1411 NORTH TATUM BLVD  
PHOENIX, AZ 85028  
PHONE: (602) 953-6539  
FAX: (602) 953-1964  
ATTN: ANDY GREENWOOD

**ENGINEER:**  
OLSSON ASSOCIATES  
7250 NORTH 16TH STREET, SUITE 210  
PHOENIX, ARIZONA 85020  
PHONE: (602) 748-1000  
FAX: (602) 748-1001  
ATTN: CARDELL ANDREWS

SITE DATA TABLE	
GROSS LOT AREA (PARCELS 173-36-004G)	352,570 SF OR 8.09 ACRES
CONSTRUCTION LIMITS	12,234 SF OR 0.28 ACRES
PARCEL ZONING	25-ZN-2015; D/DRU-2 PBD DO (DOWNTOWN DISTRICT REGIONAL COMMERCIAL OFFICE SUBDISTRICT WITHIN THE PLANNED BLOCK DEVELOPMENT AND DOWNTOWN OVERLAY)
LAND USE	RETAIL/RESTAURANT
GROSS FLOOR LEASE AREA (GFLA)	PAD D=5,000 PAD E=7,200
GROSS FLOOR AREA RATIO (G FAR)	ALLOWED= 1.3 (WITHOUT BONUSES) PROVIDED= 0.51 (12,352 GBA)
MAXIMUM BUILDING HEIGHT (DRU-2)	ALLOWED= 84' MAX PROVIDED= 30'-6"
BUILDING SETBACK (ADJACENT TO PUBLIC STREET)	REQUIRED= 30' MIN (NORTH GOLDWATER BLVD.) PROVIDED= 30' (NORTH GOLDWATER BLVD.)
PREVAILING SETBACK (FAÇADE LENGTH OF 200' +)	REQUIRED= BETWEEN 35' TO 45' (NORTH GOLDWATER BLVD.) PROVIDED= 35' (NORTH GOLDWATER BLVD.)
LANDSCAPE BUFFER	REQUIRED= 30' (NORTH GOLDWATER BLVD.) PROVIDED= 30' (NORTH GOLDWATER BLVD.)
OPEN SPACE	REQUIRED= 10% MIN PROVIDED= N/A
OFF-STREET PARKING (ENTIRE MALL)	REQUIRED= #7,675 PROVIDED= #7,933
ACCESSIBLE PARKING	REQUIRED= N/A (PROVIDED WITH LUX IMPROVEMENTS) PROVIDED= N/A
BICYCLE PARKING	REQUIRED= N/A (PROVIDED WITH LUX IMPROVEMENTS) PROVIDED= 6 SPACES

\* A TOTAL OF 133 PARKING SPACES ARE BEING ADDED WITH THE RE-DEVELOPMENT, THEREFORE THIS CALCULATION IS BASED ON 133 PARKING SPACES.  
# CROSS PARKING IS PROVIDED WITHIN THE REGIONAL SHOPPING CENTER TO SATISFY OFF STREET PARKING. PLEASE SEE PARKING PLAN EXHIBIT FOR BREAKDOWN OF REQUIRED SPACES.

**MOLSSON ASSOCIATES**

7250 North 16th Street, Suite 210  
Phoenix, AZ 85020-5292  
TEL: 602.748.1000  
FAX: 602.748.1001  
www.olsonassociates.com

---

EXPIRES 06/30/20

---

REV. NO.	REVISION DESCRIPTION	DATE

---

PRELIMINARY SITE PLAN

SCOTTSDALE FASHION SQUARE

LUXURY WING ENTRY-PAD D AND E

2018

SCOTTSDALE, ARIZONA 85251

---

drawn by: THW	designed by: SJV	checked by: AP
QA/QC by: CDR	project no: 016-3808	date: 03.20.18

**C101**

20 of 30

## APPENDIX B

**FINAL DRAINAGE REPORT**  
**SCOTTSDALE FASHION SQUARE LUXURY WING ENTRY SITE**  
**7014 E. CAMELBACK ROAD, SCOTTSDALE, ARIZONA**  
**COS CASE NO. 26-DR-2017**

Plan # 5941-17

PREPARED FOR

Case # \_\_\_\_\_

**Macerich**

Q-S # \_\_\_\_\_

**Phoenix, Arizona**

Accepted

PREPARED BY

Corrections

DG

12/27/2017

**Olsson Associates**

Reviewed By \_\_\_\_\_

Date

**7250 N. 16<sup>th</sup> Street, Suite 210**

**Phoenix, AZ 85020**

**602-748-1000**



**September 2017**

**Olsson Associates Project No. 016-3809**

**City of Scottsdale Plan Check No. 5941-17**

**City of Scottsdale Case No. 26-DR-2017**



**Table of Contents**

City of Scottsdale Drainage Report Outline— DS&PM Appendix 4-1A

City of Scottsdale Warning & Disclaimer of Liability— DS&PM Appendix 4-1C

1.0 Introduction.....2

    1.1 Purpose of Report ..... 2

    1.2 Site Description and Project Location ..... 2

    1.3 Topographic Conditions..... 3

    1.4 FEMA Flood Insurance Rate Map..... 3

2.0 Offsite Drainage.....4

3.0 Onsite Drainage.....5

    3.1 Design Standards..... 8

    3.2 Finished Floor Elevations ..... 8

    3.3 Storm System Maintenance..... 8

4.0 Conclusions .....10

5.0 References .....11

**List of Appendices**

- Appendix A FEMA FIRM Map
- Appendix B Drainage Map(s)
- Appendix C Drainage Calculations
- Appendix D Supplemental Information

**List of Figures**

- Figure 1 Vicinity Map
- Figure 1A FIRM Map
- Figure 2 Final Build-Out Exhibit
- Figure 3 Existing Conditions Drainage Map
- Figure 4 Post- Drainage Map
- Figure 5 Pre 'C' Area Exhibit
- Figure 6 Post 'C' Area Exhibit





# Appendix 4-1A DRAINAGE REPORT OUTLINE

<b>Title Page:</b> Project Name; Location; Type of Drainage Report (Preliminary, Master Plan, Final, etc.); and Engineer's Seal, Signature, and Date.
<b>Table of Contents:</b> Engineer's Seal, Signature, and Date.
<b>1. Introduction</b> <ul style="list-style-type: none"><li>• Project Name, Location, Size, and Brief Description;</li><li>• Type of Report (Preliminary, Master Plan, and Final, etc.); and</li><li>• Purpose and Objectives.</li></ul>
<b>2. Description of Existing Drainage Conditions and Characteristics</b> <ul style="list-style-type: none"><li>• On-site drainage:</li><li>• Existing drainage network, patterns, and watershed and floodplain boundaries.</li><li>• Off-site watershed:</li><li>• Existing conditions and the drainage network entering and existing the project site.</li><li>• Context relative to adjacent projects and improvements;</li><li>• Flood Hazard Zones on the property, FIRM maps.</li><li>• Site-specific photographs to support parameter selection.</li></ul>
<b>3. Proposed Drainage Plan</b> <ul style="list-style-type: none"><li>• General description of proposed drainage system and components; including conveyance of off-site flows;</li><li>• Future conditions; including development of adjacent properties;</li><li>• Stormwater storage requirements:<ul style="list-style-type: none"><li>- Volume required, volume provided, and basin locations.</li></ul></li><li>• Pre- and post- runoff characteristics at concentration points exiting the property;</li><li>• Proposed drainage structures or special drainage facilities:<ul style="list-style-type: none"><li>- Include design criteria and probable effect on the existing upstream and downstream drainage system.</li></ul></li><li>• Project Phasing:<ul style="list-style-type: none"><li>- Improvements to be constructed with each phase, impact of phased construction, and required interim improvements. Development requirements must be met independently for each phase.</li></ul></li></ul>
<b>4. Special Conditions</b> Project Stipulations, 401 and 404 Permits, AZPDES.
<b>5. Data Analysis Methods</b> <ul style="list-style-type: none"><li>• Hydrologic procedures, parameter selection and assumptions.</li><li>• Hydraulic procedures, methods, parameter selection and assumptions.</li><li>• Stormwater storage calculation methods and assumptions.</li></ul>
<b>6. Conclusions</b> <ul style="list-style-type: none"><li>• Overall Project</li><li>• Project Phasing</li></ul>
<b>7. Warning and Disclaimer of Liability</b> <ul style="list-style-type: none"><li>• Each drainage report must include a completed Warning and Disclaimer of Liability.</li></ul>
<b>8. References</b>



## Appendix 4-1A DRAINAGE REPORT OUTLINE

**Appendices** - Hydrologic and Hydraulic Data and Calculations, and a signed Warning and Disclaimer of Liability

**Electronic Input Files** - HEC-1, HEC-HMS, and HEC-2 or HEC-RAS, on Compact Disk (CD), working copy of non-standard software. A PDF file of the drainage report must also be provided that includes all exhibits, plates, figures, etc.

### **Exhibits**

- Vicinity Map
- Existing Conditions
- Topographic Map of Off-Site Watershed;
- Topographic Map of Existing On-site conditions with current 1-foot (minimum) contour mapping based on a current topographic survey.
- Current aerial photo, 800 scale or larger, showing site in context.
- Proposed On-site Drainage Plan
- Scale appropriate to type of drainage report and size of the project.



# WARNING & DISCLAIMER OF LIABILITY

The Drainage and Floodplain Regulations and Ordinances of the City of Scottsdale are intended to "minimize the occurrence of losses, hazards and conditions adversely affecting the public health, safety and general welfare which might result from flooding caused by the surface runoff of rainfall" (Scottsdale Revised Code §37-16).

As defined in S.R.C. §37-17, a flood plain or "Special flood hazard area means an area having flood and/or flood related erosion hazards as shown on a FHBM or FIRM as zone A, AO, A1-30, AE, A99, AH, or E, and those areas identified as such by the floodplain administrator, delineated in accordance with subsection 37-18(b) and adopted by the floodplain board." It is possible that a property could be inundated by greater frequency flood events or by a flood greater in magnitude than a 100-year flood. Additionally, much of the Scottsdale area is a dynamic flood area; that is, the floodplains may shift from one location to another, over time, due to natural processes.

### WARNING AND DISCLAIMER OF LIABILITY PURSUANT TO S.R.C §37-22

"The degree of flood protection provided by the requirements in this article is considered reasonable for regulatory purposes and is based on scientific and engineering considerations. Floods larger than the base flood can and will occur on rare occasions. Floodwater heights may be increased by man-made or natural causes. This article (Chapter 37, Article II) shall not create liability on the part of the city, any officer or employee thereof, or the federal government for any flood damages that result from reliance on this article or any administrative decision lawfully made thereunder."

Compliance with Drainage and Floodplain Regulations and Ordinances does not insure complete protection from flooding. The Floodplain Regulations and Ordinances meet established local and federal standards for floodplain management, but neither this review nor the Regulations and Ordinances take into account such flood related problems as natural erosion, streambed meander or man-made obstructions and diversions, all of which may have an adverse affect in the event of a flood. You are advised to consult your own engineer or other expert regarding these considerations.

I have read and understand the above. If I am an agent for an owner I have made the owner aware of and explained this disclaimer.

26-DR-2017  
Plan Check No.

  
Owner or Agent

8/8/17  
Date

## 1.0 INTRODUCTION

### 1.1 Purpose of Report

The purpose of this final drainage report is to provide hydrologic and hydraulic documentation for the proposed Scottsdale Fashion Square Luxury Wing commercial site. More specifically, a design review of surface grading, and offsite flows that impact the site. The project will be designed and developed in accordance with the City of Scottsdale and Maricopa County's current development standards and client requirements.

Per City of Scottsdale, Stormwater Management Division, Scottsdale Redevelopment Stormwater Storage Policy will apply to this site.

### 1.2 Site Description and Project Location

The proposed Scottsdale Fashion Square Luxury Wing Site (hereinafter referred to as the Project) consists of a commercial development with project zoning D/RCO-2 PBD covering approximately 4.81 acres. The Project is located within a portion of the Northeast Quarter of Section 22, Township 2 North, Range 4 East of the Gila and Salt River Meridian, Maricopa County, Arizona. More specifically, the project is located near the northwest corner of Camelback Road and Goldwater Boulevard in Scottsdale Fashion Square (see **Figure 1. Vicinity Map** below).



Figure 1: Vicinity Map

The site is currently developed as part of the greater Scottsdale Fashion Square Shopping Mall. Buildings, parking lot, and open space area will be redeveloped in multiple phases including restaurants, valet services and retail stores. This report accounts for the complete buildout of the 4.81-acre site, as provided in **Table 1** below (also refer to **Figure 6** in **Appendix B**). The Project is bounded by Highland Avenue to the north, Goldwater Boulevard to the east, Scottsdale Fashion Square Shopping Mall to the south and the mall's purple parking garage to the west. Site access to the public street system will be provided along Goldwater Boulevard.

**Table 1. Final Buildout Gross Floor Area**

Area ID	Use	Gross Building Floor Area (SF)	Building Cover (SF)
<b>PAD A</b>	Restaurant	12,335 SF	12,335 SF
<b>PAD B</b>	Restaurant	7,100 SF	7,100 SF
<b>PAD C</b>	Restaurant/Retail	9,240 SF	12,352 SF
<b>PAD F</b>	Restaurant	3,900 SF	3,900 SF
<b>BOLT-ON</b>	Shops- Mall addition	12,000 SF	14,131 SF

### 1.3 Topographic Conditions

The existing ground slopes from the northwest to the southeast at a 0.9 % slope. **Figure 3** in **Appendix B** presents the existing topographic conditions for the Project. Both Goldwater Boulevard and Highland Avenue have been fully improved with catch basin inlets for stormwater runoff.

### 1.4 FEMA Flood Insurance Rate Map

The project is entirely located within Zone "X" according to Flood Insurance Rate Map (FIRM) Panel 04013C1770L which is effective October 16, 2013 (REF 1). Zone X is defined as: "Areas of 0.2% annual chance flood; areas of 1% annual chance flood with average depths of less than 1 foot or with drainage areas less than 1 square mile; and areas protected by levees from 1% annual chance flood." (Please refer to the **Figure 1A**, Flood Insurance Rate Map in **Appendix A**).

## 2.0 OFFSITE DRAINAGE

Offsite watershed conditions have been detailed within the existing Master Drainage Report from Collar, Williams & White Engineering, and will not be modified by this project.

Both Goldwater Boulevard and Highland Avenue are fully improved with catch basin inlets. Since these adjacent streets have been fully improved and the Project is not proposing to do street modifications, no analysis of street capacity or inlet capacity is presented with this report.

In the current condition, runoff from Highland Avenue is carried east in the gutter and then passes through a scupper into an existing storm system that crosses Goldwater Boulevard and eventually heads to Scottsdale Road.

Goldwater Boulevard runoff drains south and collects runoff in inlets south of the project site, which then drains south via storm sewer to Camelback Road.

Based on the existing Master Drainage Report (REF 6) from Collar, Williams & White Engineering, date May 10, 1988 (**Appendix D**), the runoff collected from the site discharges into an existing 84-inch storm drain pipe in Camelback Road and an existing 42-inch storm drain pipe located in Scottsdale Road. These two pipes connect to a 144-inch storm drain pipe which ultimately drains to Indian Bend Wash (See **Existing Conditions Drainage Map** in **Appendix B** for more details).

The Project site outfall will be at the southeast corner of the site onto Goldwater Boulevard as it has been historically directed.

Offsite drainage does not affect this project.

### 3.0 ONSITE DRAINAGE

The existing developed site has a storm sewer system that collects runoff and discharges into various storm water systems along Goldwater Boulevard. **Figure 3** shows the storm sewer system along with storm pipe flow direction, as well as outlining what sub areas drain to each existing inlet of the storm sewer system.

In reviewing the existing as-builts for *Camelview Plaza North Parking Lot*, approved by City of Scottsdale in 1990, there are three landscape areas in the southeast corner of the site, located west of Goldwater Boulevard, that were originally designed as retention basins (see **Figure 3**). Since volumes were not provide on the *Camelview Plaza North Parking Lot* plan, volumes were reproduced utilizing the current field survey. The existing basin volumes reproduced utilizing the field survey are provided below, as well as being depicted on **Figure 3**. Retention Basin No. 1 captures rainfall that falls directly on the said area, as well as flow-by drainage through two existing curb openings. Retention Basin No. 2 captures rainfall that falls directly on the said area, as well as a small area of asphalt located west of the basin. Retention Basin No. 3 captures rainfall that falls directly on the said area, as well as flow-by drainage through one existing curb opening. It should be noted that all three basins were not designed to have large surface areas directed towards the existing retention basins.

**Existing Retention Basin Volumes**

EX. Basin ID (Per Figure 3)	Ponding Depth (FT)	Volume (CF)
Basin No. 1	1	1,487
Basin No. 2	1	1,618
Basin No. 3	1	449
Total		3,554

Meeting the requirements of the City of Scottsdale Redevelopment Stormwater Storage Policy, Retention Basin No. 1 has been retained and resized to capture a larger volume of drainage runoff in the proposed condition than in the existing condition. In keeping Retention Basin No. 1, the two existing flow-by drainage curb openings will also be retained in place to continue to provide a drainage capture location. Retention Basins No. 2 and 3 will be removed due to Phase II improvements of PAD C, which will encumber the entire area once used by Basin No. 2 and 3 (see **Figure 4**). To accommodate the lost volumes provided by Retention Basin No. 2 and 3, water harvesting areas have been located throughout the site to capture drainage in landscape areas (see **Figure 4**). The proposed volumes created by resizing Retention Basin No. 1, as well as the volumes created by the landscape water harvesting basins, are provided in the table below.

**Proposed Retention Volumes**

Basin ID (Per Figure 4)	Ponding Depth (FT)	Volume (CF)
Basin No. 1	1	2,205
Water Harvesting Areas	0.50	1,363
Total		3,568

Land use areas for the site were determined for the existing and proposed conditions (see **Figure 5** for existing conditions and **Figure 6** for proposed conditions) and used to find a weighted C coefficient for both conditions. The coefficient assumptions used to determine the weighted coefficient of 0.91 are summarized in **Table 1** below. Calculations to support the weighted coefficient values are shown in **Appendix C**.

**Table 1. Land Use 'C' Coefficient Assumptions**

Land Use	Building Area	Paved Area	Desert Landscape Area	Grassed Area
C=	0.95	0.95	0.83	0.30

Area Condition	Total Area (SF)	Building (C=.95) (SF)	Paved (C=.95) (SF)	Desert Landscape (C=0.83) (SF)	Grassed (C=0.30) (SF)	Weighted C
Pre	209,704	18,477	145,564	39,968	5,695	0.91
Post	209,704	50,448	122,780	28,875	7,601	0.91
					Difference	0.00

The results show that the project will have no overall change in land use with the pre and post 'C' coefficient both equaling 0.91. This means that a pre-vs-post comparison will show no net change.

**PRE**

V= A\*C\*P, where

A (Site Area SF)= 209,704 SF

P= 2.18 inches, 100 YR-2 HR

C= 0.91

V= 209,704 SF x 0.91 x (2.18 in/hr/12)= 34,668 CF

**POST**

V= A\*C\*P, where

A (Site Area SF)= 209,704 SF

P= 2.18 inches, 100 YR-2 HR

C= 0.91

V= 209,704 SF x 0.91 x (2.18 in/hr/12)= 34,668 CF

**PRE vs POST**

PRE - Post= 34,668 CF - 34,668 CF= 0 CF

Per the City of Scottsdale, if First Flush Volume is greater than the pre vs post volume, then the First Flush Volume shall be used. Since the pre vs post volume came back with no difference in volume, the First Flush Volume was utilized. The first flush volume is calculated as follows:

**First Flush Volume Required**

$V_{FF} = A \cdot C \cdot P$ , where

A (Site Area SF)= 209,704 SF

$P_{FF} = 0.5$  inches

C= 0.91

$V = 209,704 \text{ SF} \times 0.91 \times (0.5 \text{ in/hr}/12) = 7,951 \text{ CF}$

To meet the City of Scottsdale First Flush Requirement, a hydrodynamic separator will be installed with the proposed site improvements, and will be positioned onsite to treat the volume that equates to that equal or more than the First Flush Volume calculated for the overall site.

**SITE VOLUME TREATED (SUB AREAS A01, A02, A03, A04 AND A05)**

$V = A \cdot C \cdot P$ , where

A (Site Area SF)= 87,556 SF

P= 2.18 inches, 100 YR-2 HR

C= 0.91

$V = 87,556 \text{ SF} \times 0.91 \times (2.18 \text{ in/hr}/12) = \mathbf{14,474 \text{ CF}} > 7,951 \text{ CF}$

The use of City of Phoenix and Maricopa County, Rational Rainfall Method for "First Flush" Flowrate ( $Q_{FF} = CIA$ , where C= 1.0 and  $P_{FF} = 0.5$ ) was used to size a hydrodynamic separator, as the City of Scottsdale has no direct calculation or requirement (see calculation below). The hydrodynamic separator selected for the flow rate calculated is a Contech Vortsenry HS96, which is designed to treat up to 8.10 CFS of runoff before discharging into the existing storm sewer. As calculated above, the system will be located on site to treat sub-basins A01, A02, A03, A04 and A05 for a total of 2.01 acres. See below for the actual flowrate calculations.

**MARICOPA COUNTY RATIONAL RAINFALL METHOD FOR “FIRST FLUSH” FLOWRATE (HYDRODYNAMIC SEPARATOR)**

$P_{FF} = 0.5$  inches

$Q_{FF} = CIA$ , where  $C = 1.0$  and

$I = (0.5 \text{ in/hr} \times 60 \text{ min/hr}) / T_c$ , assume  $T_c = 15 \text{ min}$

$Q_{FF} = 1.0 \times (0.5 \text{ in/hr} \times 60 \text{ min/hr}) / 15 \times 2.01 = \mathbf{4.00 \text{ CFS}} < 8.10 \text{ CFS}$

Analysis was done to ensure that site modifications will not alter existing drainage patterns in a negative way. Sub-areas, with the resulting flow rate calculations are shown in **Figures 3 and 4** in **Appendix B** showing a site breakdown of drainage patterns for both the pre and post conditions (see **Table 2. Analysis Focus Points Summary** for results).

**Table 2. Analysis Focus Points Summary**

Area ID	Outlet Point	Existing Area (Acres)	Proposed Area (Acres)	Difference (Acres)
<b>A</b>	Existing 18" storm sewer	3.14	3.30	+0.17
<b>B</b>	Existing grate inlets south of site	0.84	0.54	-0.30
<b>C</b>	Existing storm sewer crossing Goldwater	0.23	0.16	-0.07
<b>D</b>	Goldwater Boulevard street gutter	0.61	0.81	+0.20

The table shows that inlets for areas A and D will take on a small additional volume in the post condition. Based on our calculations, the additional volumes present no issue.

**3.1 Design Standards**

Onsite drainage will be designed and constructed to conform to the City of Scottsdale *Design Standards & Policies Manual, Chapter 4* (REF 2) and the Flood Control District of Maricopa County's *Drainage Design Manual for Maricopa County, Arizona, Volume 1, Hydrology and Volume II, Hydraulics* (Ref 4 & 5).

**3.2 Finished Floor Elevations**

The proposed finish floor elevation for all phases of the project will be much greater than 14" above the site outfall. The ultimate outfall for the site is at a 1270.70 while the minimum finished floor elevation will be set at 1291.00.

**3.3 Storm System Maintenance**

Ongoing maintenance of the designed drainage systems is required to preserve their design integrity. Poor maintenance can prevent the system from performing to its intended design purpose and can result in reduced performance. Maintenance is the responsibility of the property owner for facilities on private property. A regular maintenance program is required to ensure drainage systems perform to the level of protection or service as presented in this report and the project's plans and specifications.

#### 4.0 CONCLUSIONS

The following conclusions have been reached as a result of this drainage investigation, in support of the proposed Scottsdale Fashion Square Luxury Wing Project:

- This drainage report was prepared in accordance with the recommendations and design parameters from the City of Scottsdale *Design Standards & Policies Manual, Chapter 4* (REF 2), and *MCFCD Drainage Design Manuals, Volume I and II* (REF 4&5).
- The proposed Drainage plan maintains the existing drainage patterns and flows. The proposed drainage will continue to drain to the existing storm system as outlined in the *Master Drainage Plan for Scottsdale Fashion Square* approved August 18, 1986, revised May 10, 1988, by Collar, Williams & White Engineering (**Appendix D**).
- Per our discussion with the City of Scottsdale Stormwater Management Division, this project is required to meet City of Scottsdale Redevelopment Stormwater Storage Policy.
- The project is entirely located within Zone "X" according to FIRM Panel 04013C1770L. Zone X is defined as: "Areas of 0.2% annual chance flood; areas of 1% annual chance flood with average depths of less than 1 foot or with drainage areas less than 1 square mile; and areas protected by levees from 1% annual chance flood." (**Appendix A**)
- A Storm Water General Permit has been obtained through ADEQ, and is listed as AZPDES Stormwater Construction General Permit (CGP) ID #: AZCN69125 (**Appendix D**).
- The manufacturers Operation, Design, Performance, and Maintenance Guidelines is provided in **Appendix D**.

## 5.0 REFERENCES

1. Flood Insurance Rate Map, Maricopa County, Arizona, Map Number 04013C1770L, Federal Emergency Management Agency, Washington DC, October 16, 2013.
2. City of Scottsdale Design Standards & Policies Manual, Chapter 4, City of Scottsdale, AZ, January 2010.
3. MAG Uniform Standard Details for Public Works Construction, Maricopa Association of Governments, Phoenix, AZ, 2015 Revision.
4. Drainage Design Manual for Maricopa County, Arizona – Hydrology, 4<sup>th</sup> Edition, Flood Control District of Maricopa County, Phoenix, AZ, August 15, 2013.
5. Drainage Design Manual for Maricopa County, Arizona – Hydraulics, 3<sup>rd</sup> Edition, Flood Control District of Maricopa County, Phoenix, AZ, August 15, 2013.
6. Master Drainage Plan for Scottsdale Fashion Square, Collar, Williams & White Engineering, May 10, 1988.
7. Maricopa County (2016, June 1). Standard 6.4.1 First Flush. Drainage Policies and Standards for Maricopa County, Arizona
8. City of Phoenix (2011, April). 6.8.3 First Flush. Stormwater Policies and Standards



# APPENDIX A FEMA FIRM MAP

---



MAP SCALE 1" = 1000'

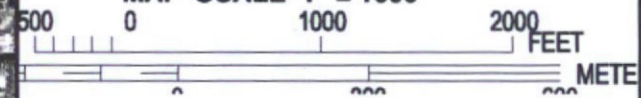

MARICOPA COUNTY  
UNINCORPORATED AREA  
040037



915000 FT

910000 FT

33°30'00.0"

111°56'15.0"

413<sup>000</sup>m E

414<sup>000</sup>m E

NFIP

PANEL 1770/L

NATIONAL FLOOD INSURANCE PROGRAM

**FIRM**  
FLOOD INSURANCE RATE MAP  
MARICOPA COUNTY,  
ARIZONA  
AND INCORPORATED AREAS

**PANEL 1770 OF 4425**  
(SEE MAP INDEX FOR FIRM PANEL LAYOUT)

CONTAINS:

COMMUNITY	NUMBER	PANEL	SUFFIX
MARICOPA COUNTY	040037	1770	L
PARADISE VALLEY, TOWN OF	040049	1770	L
SCOTTSDALE, CITY OF	045012	1770	L

Notice to User: The **Map Number** shown below should be used when placing map orders; the **Community Number** shown above should be used on insurance applications for the subject community.



**MAP NUMBER**  
04013C1770L  
**MAP REVISED**  
OCTOBER 16, 2013

Federal Emergency Management Agency

This is an official copy of a portion of the above referenced flood map. It was extracted using F-MIT On-Line. This map does not reflect changes or amendments which may have been made subsequent to the date on the title block. For the latest product information about National Flood Insurance Program flood maps check the FEMA Flood Map Store at [www.msc.fema.gov](http://www.msc.fema.gov)



# APPENDIX B DRAINAGE MAP(S)

P:\3161\3161-ADD\3161-3003\40-Design\MapArea\SCA\SCA\_Site\_Map\3161\_06\3161\_06.dwg USER: c:\praise\_3161\_06  
 DATE: Nov 01, 2017 5:50pm REV: 1 C:\praise\_3161\_06\3161\_06.dwg C:\praise\_3161\_06\3161\_06.dwg

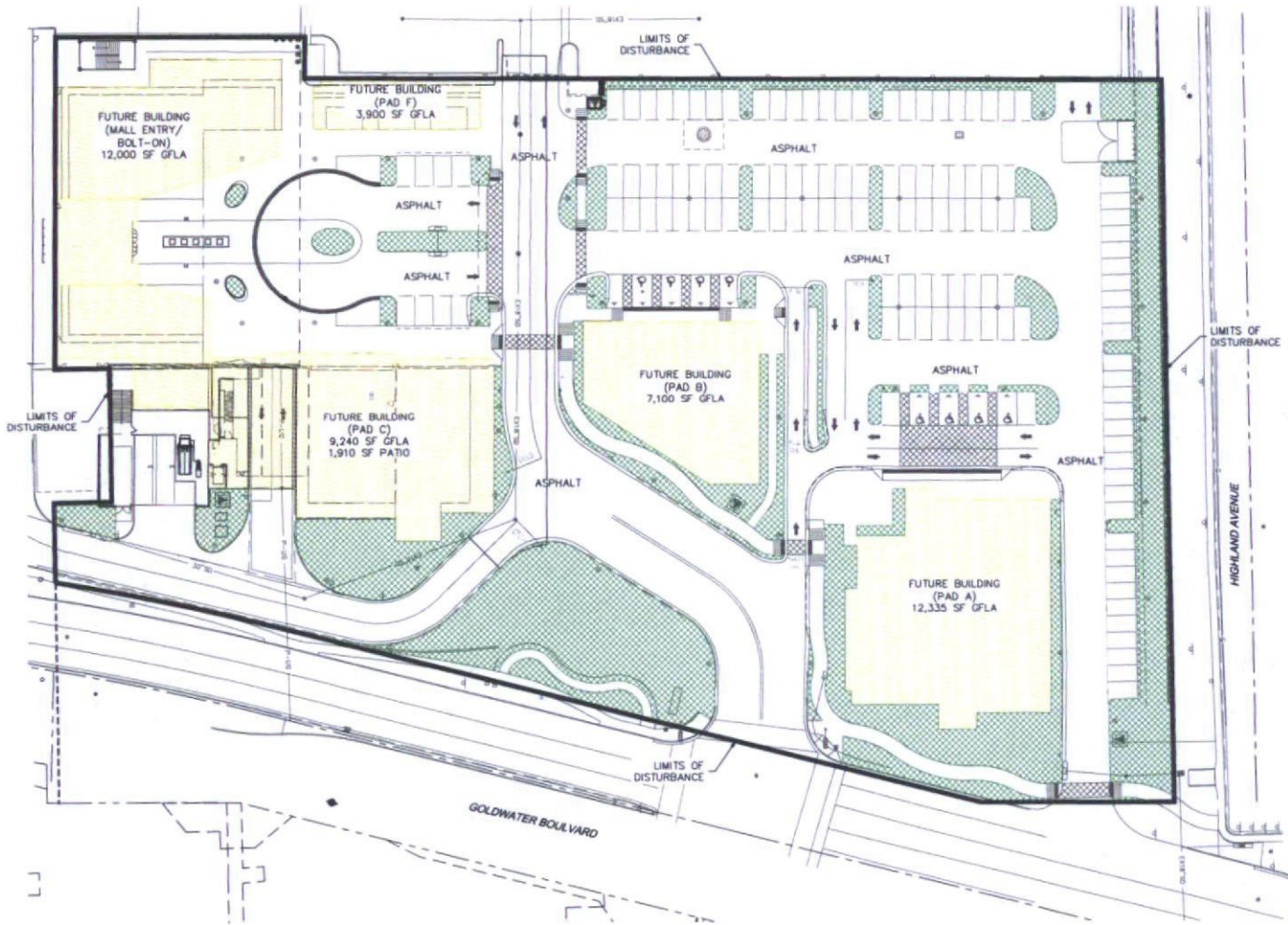

**FUTURE BUILD-OUT SUMMARY**

FUTURE/PROPOSED BUILDING/PATIO AREA	48,485 SF GFLA
LANDSCAPE AREA	60,994 SF

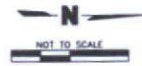

MOLSSON ASSOCIATES ASSUMES  
 NO RESPONSIBILITY FOR  
 EXISTING UTILITY LOCATIONS  
 HORIZONTAL OR VERTICAL. THE  
 EXISTING UTILITIES SHOWN ON  
 THIS DRAWING HAVE BEEN  
 PLOTTED FROM THE BEST  
 AVAILABLE INFORMATION. IT IS  
 THE RESPONSIBILITY OF THE  
 CONTRACTOR TO FIELD  
 VERIFY THE LOCATION OF ALL  
 UTILITIES PRIOR TO THE  
 COMMENCEMENT OF ANY  
 CONSTRUCTION ACTIVITIES.

REV. NO.	DATE	REVISION DESCRIPTION

**FINAL BUILD-OUT EXHIBIT**  
**GROSS FLOOR LEASE AREA**  
**SCOTTSDALE FASHION SQUARE**  
**LUXURY WING ENTRY**  
 SCOTTSDALE, ARIZONA 85251

Drawn by	
Designed by	
Checked by	
QA/QC by	
By	
Date	11/01/2017

**FIGURE 2**







# APPENDIX C DRAINAGE CALCULATIONS

**Scottsdale Fashion Square - Luxury Wing Entry**  
**Preliminary Drainage Calcs**

Oct-17

BY: SJV

Pre vs Post - "C" Coefficient Calculations

Area Condition	Total Area (sf)	Total Area (ac)	Building (C=.95) (sf)	Paved (C=.95) (sf)	Desert Landscape (C=0.83) (sf)	Grassed (C=0.30) (sf)	Weighted C
Pre	209,704	4.81	18,477	145,564	39,968	5,695	0.91
Post	209,704	4.81	50,448	122,780	28,875	7,601	0.91
						Difference	0.00

# SCOTTSDALE FASHION SQUARE- LUXURY WING ENTR

## Drainage Report

### Flow Rate at Inlet Calculations

#### Contributing Areas A01,A02,A03

Inlet Location:	CB B1	Area:	1.39	Acres
Runoff Coefficient:	0.91	Time of Concentration:	5	min
Frequency:	10	100	year	
Intensity:	4.73	7.48	in/hr	
Discharge:	5.98	9.46	cfs	

#### Contributing Areas A04, A05

Inlet Location:	CB B2	Area:	0.62	Acres
Runoff Coefficient:	0.91	Time of Concentration:	5	min
Frequency:	10	100	year	
Intensity:	4.73	7.48	in/hr	
Discharge:	2.67	4.22	cfs	

#### Contributing Areas 1/2 of A06, A07, A08, A09, A10

Inlet Location:	CB C1	Area:	0.655	Acres
Runoff Coefficient:	0.91	Time of Concentration:	5	min
Frequency:	10	100	year	
Intensity:	4.73	7.48	in/hr	
Discharge:	2.82	4.46	cfs	

#### Contributing Areas 1/2 of A06, A07, A08, A09, A10

Inlet Location:	CB C2	Area:	0.655	Acres
Runoff Coefficient:	0.91	Time of Concentration:	5	min
Frequency:	10	100	year	
Intensity:	4.73	7.48	in/hr	
Discharge:	2.82	4.46	cfs	

#### Contributing Areas C01

Inlet Location:	CB A1	Area:	0.16	Acres
Runoff Coefficient:	0.91	Time of Concentration:	5	min
Frequency:	10	100	year	
Intensity:	4.73	7.48	in/hr	
Discharge:	0.69	1.09	cfs	

## Worksheet for CB-A1

### Project Description

Solve For Spread

### Input Data

Discharge		1.09	ft <sup>3</sup> /s
Gutter Width		2.50	ft
Gutter Cross Slope		0.06	ft/ft
Road Cross Slope		0.02	ft/ft
Local Depression		0.00	in
Local Depression Width		0.00	ft
Grate Width		1.00	ft
Grate Length		3.50	ft
Grate Type	P-50 mm (P-1-7/8")		
Clogging		50.00	%
Curb Opening Length		2.80	ft
Opening Height		0.42	ft
Curb Throat Type	Horizontal		
Throat Incline Angle		90.00	degrees

### Options

Calculation Option Use Both

### Results

Spread	5.54	ft
Depth	0.20	ft
Gutter Depression	0.11	ft
Total Depression	0.11	ft
Open Grate Area	1.58	ft <sup>2</sup>
Active Grate Weir Length	4.50	ft





## Worksheet for CB-C1

### Project Description

Solve For                      Spread

### Input Data

Discharge		4.46	ft <sup>3</sup> /s
Gutter Width		2.50	ft
Gutter Cross Slope		0.06	ft/ft
Road Cross Slope		0.02	ft/ft
Local Depression		0.00	in
Local Depression Width		0.00	ft
Grate Width		1.00	ft
Grate Length		3.50	ft
Grate Type	P-50 mm (P-1-7/8")		
Clogging		50.00	%
Curb Opening Length		2.80	ft
Opening Height		0.42	ft
Curb Throat Type	Horizontal		
Throat Incline Angle		90.00	degrees

### Options

Calculation Option                      Use Both

### Results

Spread	20.95	ft
Depth	0.43	ft
Gutter Depression	0.11	ft
Total Depression	0.11	ft
Open Grate Area	1.58	ft <sup>2</sup>
Active Grate Weir Length	4.50	ft

## Worksheet for CB-C2

### Project Description

Solve For                      Spread

### Input Data

Discharge		4.46	ft <sup>3</sup> /s
Gutter Width		2.50	ft
Gutter Cross Slope		0.06	ft/ft
Road Cross Slope		0.02	ft/ft
Local Depression		0.00	in
Local Depression Width		0.00	ft
Grate Width		1.00	ft
Grate Length		3.50	ft
Grate Type	P-50 mm (P-1-7/8")		
Clogging		50.00	%
Curb Opening Length		2.80	ft
Opening Height		0.42	ft
Curb Throat Type	Horizontal		
Throat Incline Angle		90.00	degrees

### Options

Calculation Option                      Use Both

### Results

Spread	20.95	ft
Depth	0.43	ft
Gutter Depression	0.11	ft
Total Depression	0.11	ft
Open Grate Area	1.58	ft <sup>2</sup>
Active Grate Weir Length	4.50	ft



NOAA Atlas 14, Volume 1, Version 5  
 Location name: Scottsdale, Arizona, USA\*  
 Latitude: 33.5043°, Longitude: -111.9314°  
 Elevation: 1290.29 ft\*\*  
 \* source: ESRI Maps  
 \*\* source: USGS



**POINT PRECIPITATION FREQUENCY ESTIMATES**

Sanja Perica, Sarah Dietz, Sarah Heim, Lillian Hiner, Kazungu Maitaria, Deborah Martin, Sandra Pavlovic, Ishani Roy, Carl Trypaluk, Dale Unruh, Fenglin Yan, Michael Yekta, Tan Zhao, Geoffrey Bonnin, Daniel Brewer, Li-Chuan Chen, Tye Parzybok, John Yarchoan

NOAA, National Weather Service, Silver Spring, Maryland

[PF tabular](#) | [PF graphical](#) | [Maps & aeriels](#)

**PF tabular**

<b>PDS-based point precipitation frequency estimates with 90% confidence intervals (in inches)<sup>1</sup></b>										
Duration	Average recurrence interval (years)									
	1	2	5	10	25	50	100	200	500	1000
5-min	0.184 (0.155-0.225)	0.241 (0.203-0.294)	0.328 (0.273-0.398)	0.394 (0.327-0.476)	0.484 (0.395-0.582)	0.553 (0.446-0.662)	0.623 (0.493-0.744)	0.696 (0.541-0.829)	0.792 (0.600-0.946)	0.866 (0.642-1.04)
10-min	0.281 (0.235-0.342)	0.367 (0.309-0.448)	0.498 (0.416-0.605)	0.599 (0.498-0.725)	0.736 (0.601-0.885)	0.841 (0.678-1.01)	0.949 (0.751-1.13)	1.06 (0.823-1.26)	1.21 (0.913-1.44)	1.32 (0.978-1.58)
15-min	0.348 (0.292-0.424)	0.455 (0.383-0.555)	0.618 (0.516-0.751)	0.743 (0.617-0.898)	0.912 (0.745-1.10)	1.04 (0.841-1.25)	1.18 (0.930-1.40)	1.31 (1.02-1.57)	1.49 (1.13-1.78)	1.63 (1.21-1.95)
30-min	0.468 (0.393-0.572)	0.612 (0.516-0.747)	0.832 (0.695-1.01)	1.00 (0.831-1.21)	1.23 (1.00-1.48)	1.41 (1.13-1.68)	1.58 (1.25-1.89)	1.77 (1.37-2.11)	2.01 (1.52-2.40)	2.20 (1.63-2.63)
60-min	0.579 (0.486-0.707)	0.757 (0.638-0.925)	1.03 (0.860-1.25)	1.24 (1.03-1.50)	1.52 (1.24-1.83)	1.74 (1.40-2.08)	1.96 (1.55-2.34)	2.19 (1.70-2.61)	2.49 (1.89-2.97)	2.72 (2.02-3.26)
2-hr	0.673 (0.572-0.803)	0.871 (0.741-1.04)	1.17 (0.988-1.39)	1.39 (1.17-1.65)	1.70 (1.41-2.00)	1.93 (1.58-2.28)	2.18 (1.75-2.56)	2.42 (1.91-2.85)	2.75 (2.12-3.24)	3.01 (2.27-3.56)
3-hr	0.734 (0.622-0.885)	0.941 (0.801-1.14)	1.24 (1.05-1.49)	1.47 (1.23-1.76)	1.80 (1.48-2.14)	2.06 (1.68-2.44)	2.33 (1.86-2.77)	2.62 (2.06-3.10)	3.01 (2.29-3.57)	3.33 (2.47-3.95)
6-hr	0.884 (0.784-1.04)	1.12 (0.970-1.32)	1.44 (1.24-1.69)	1.69 (1.44-1.97)	2.03 (1.71-2.36)	2.30 (1.91-2.66)	2.58 (2.11-2.99)	2.86 (2.30-3.32)	3.25 (2.55-3.78)	3.56 (2.72-4.15)
12-hr	0.988 (0.863-1.15)	1.25 (1.09-1.45)	1.58 (1.37-1.83)	1.84 (1.59-2.13)	2.20 (1.87-2.53)	2.47 (2.08-2.84)	2.75 (2.28-3.16)	3.03 (2.48-3.49)	3.41 (2.73-3.95)	3.70 (2.91-4.32)
24-hr	1.18 (1.05-1.34)	1.50 (1.33-1.71)	1.94 (1.72-2.21)	2.30 (2.03-2.61)	2.78 (2.44-3.16)	3.17 (2.76-3.58)	3.57 (3.09-4.04)	3.99 (3.42-4.51)	4.56 (3.87-5.16)	5.02 (4.21-5.89)
2-day	1.28 (1.13-1.45)	1.63 (1.45-1.85)	2.14 (1.90-2.42)	2.65 (2.25-2.88)	3.12 (2.74-3.52)	3.57 (3.12-4.04)	4.05 (3.52-4.58)	4.55 (3.92-5.15)	5.25 (4.47-5.95)	5.81 (4.90-6.61)
3-day	1.35 (1.20-1.53)	1.73 (1.53-1.96)	2.28 (2.01-2.57)	2.72 (2.39-3.07)	3.34 (2.93-3.77)	3.83 (3.34-4.33)	4.36 (3.78-4.93)	4.92 (4.22-5.56)	5.70 (4.84-6.45)	6.34 (5.32-7.19)
4-day	1.43 (1.26-1.62)	1.83 (1.62-2.07)	2.41 (2.13-2.72)	2.88 (2.54-3.26)	3.55 (3.11-4.01)	4.09 (3.56-4.62)	4.67 (4.04-5.27)	5.29 (4.53-5.97)	6.16 (5.20-6.94)	6.86 (5.74-7.76)
7-day	1.59 (1.41-1.81)	2.03 (1.80-2.31)	2.69 (2.37-3.05)	3.22 (2.83-3.64)	3.97 (3.46-4.49)	4.57 (3.97-5.16)	5.21 (4.49-5.89)	5.90 (5.04-6.67)	6.86 (5.79-7.76)	7.64 (6.39-8.66)
10-day	1.72 (1.53-1.95)	2.21 (1.95-2.50)	2.91 (2.57-3.29)	3.49 (3.07-3.93)	4.28 (3.75-4.82)	4.93 (4.28-5.53)	5.61 (4.84-6.30)	6.32 (5.42-7.12)	7.33 (6.21-8.25)	8.14 (6.82-9.18)
20-day	2.12 (1.89-2.39)	2.73 (2.42-3.07)	3.61 (3.20-4.05)	4.27 (3.78-4.79)	5.16 (4.55-5.79)	5.85 (5.14-6.56)	6.55 (5.72-7.35)	7.26 (6.31-8.16)	8.22 (7.08-9.26)	8.96 (7.66-10.1)
30-day	2.48 (2.19-2.79)	3.19 (2.83-3.59)	4.21 (3.72-4.73)	4.98 (4.40-5.59)	6.02 (5.29-6.75)	6.82 (5.96-7.64)	7.64 (6.65-8.55)	8.47 (7.34-9.48)	9.59 (8.25-10.8)	10.5 (8.93-11.8)
45-day	2.87 (2.55-3.22)	3.69 (3.29-4.15)	4.87 (4.33-5.47)	5.74 (5.09-6.44)	6.89 (6.09-7.72)	7.75 (6.83-8.70)	8.63 (7.57-9.68)	9.50 (8.30-10.7)	10.7 (9.25-12.0)	11.5 (9.94-13.0)
60-day	3.17 (2.83-3.55)	4.09 (3.66-4.58)	5.39 (4.80-6.02)	6.33 (5.63-7.08)	7.55 (6.70-8.44)	8.46 (7.48-9.46)	9.37 (8.25-10.5)	10.3 (9.00-11.5)	11.4 (9.97-12.8)	12.3 (10.7-13.9)

<sup>1</sup> Precipitation frequency (PF) estimates in this table are based on frequency analysis of partial duration series (PDS). Numbers in parenthesis are PF estimates at lower and upper bounds of the 90% confidence interval. The probability that precipitation frequency estimates (for a given duration and average recurrence interval) will be greater than the upper bound (or less than the lower bound) is 5%. Estimates at upper bounds are not checked against probable maximum precipitation (PMP) estimates and may be higher than currently valid PMP values. Please refer to NOAA Atlas 14 document for more information.

[Back to Top](#)

PF graphical

PDS-based depth-duration-frequency (DDF) curves  
 Latitude: 33.5043°, Longitude: -111.9314°

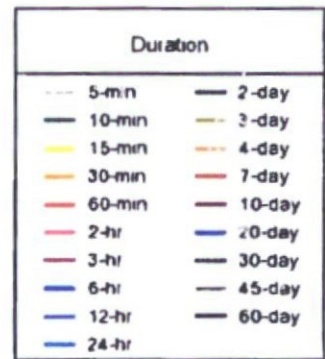
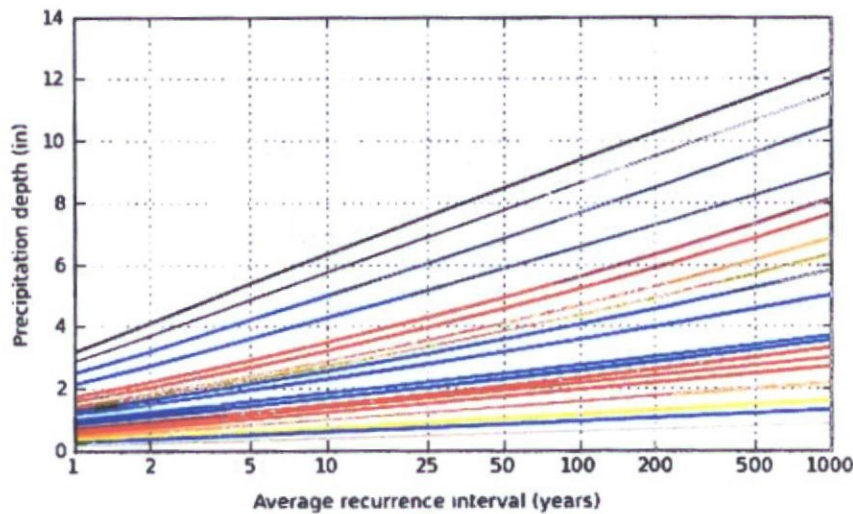
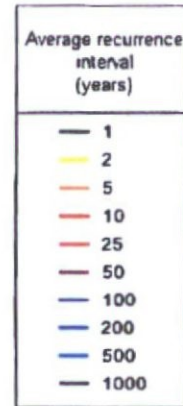
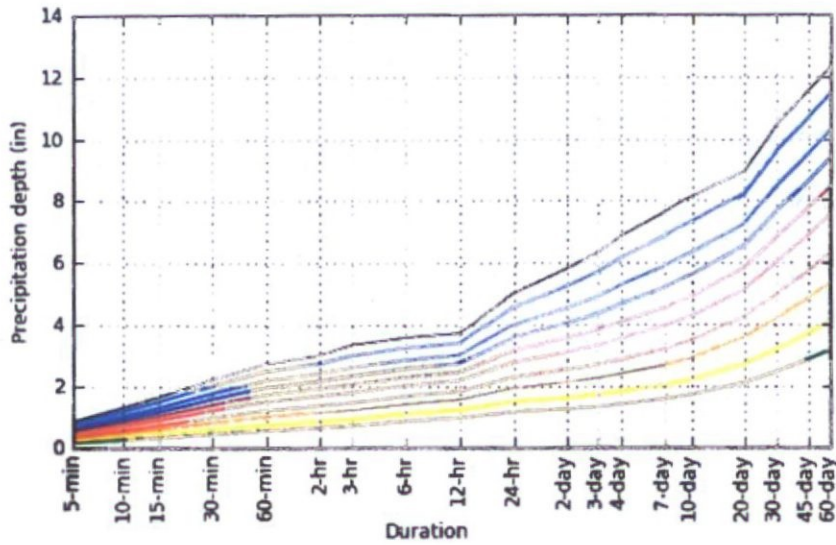

### Maps & aerials

Small scale terrain



Large scale terrain



Large scale map

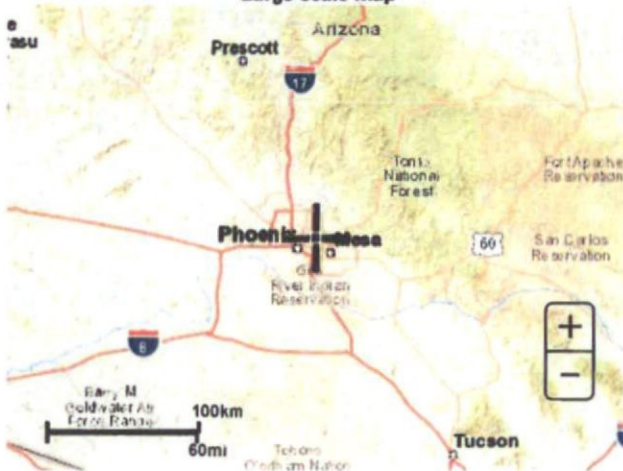

Large scale aerial



[Back to Top](#)

---

[US Department of Commerce](#)  
[National Oceanic and Atmospheric Administration](#)  
[National Weather Service](#)  
[National Water Center](#)  
1325 East West Highway  
Silver Spring, MD 20910  
Questions?: [HDSC.Questions@noaa.gov](mailto:HDSC.Questions@noaa.gov)

[Disclaimer](#)



NOAA Atlas 14, Volume 1, Version 5  
 Location name: Scottsdale, Arizona, USA\*  
 Latitude: 33.5043°, Longitude: -111.9314°  
 Elevation: 1290.29 ft\*\*  
 \* source: ESRI Maps  
 \*\* source: USGS



**POINT PRECIPITATION FREQUENCY ESTIMATES**

Sanja Perica, Sarah Dietz, Sarah Heim, Lillian Hiner, Kazungu Maitaria, Deborah Martin, Sandra Pavlovic, Ishani Roy, Carl Trypaluk, Dale Unruh, Fenglin Yan, Michael Yekta, Tan Zhao, Geoffrey Bonnin, Daniel Brewer, Li-Chuan Chen, Tye Parzybok, John Yarchoan

NOAA, National Weather Service, Silver Spring, Maryland

[PF tabular](#) | [PF graphical](#) | [Maps & aerals](#)

**PF tabular**

PDS-based point precipitation frequency estimates with 90% confidence intervals (in inches/hour) <sup>1</sup>										
Duration	Average recurrence interval (years)									
	1	2	5	10	25	50	100	200	500	1000
5-min	2.21 (1.86-2.70)	2.89 (2.44-3.53)	3.94 (3.28-4.78)	4.73 (3.92-5.71)	5.81 (4.74-6.98)	6.64 (5.35-7.94)	7.48 (5.92-8.93)	8.35 (6.49-9.95)	9.50 (7.20-11.4)	10.4 (7.70-12.4)
10-min	1.69 (1.41-2.05)	2.20 (1.85-2.69)	2.99 (2.50-3.63)	3.59 (2.99-4.35)	4.42 (3.61-5.31)	5.05 (4.07-6.04)	5.69 (4.51-6.80)	6.35 (4.94-7.57)	7.23 (5.48-8.63)	7.90 (5.87-9.46)
15-min	1.39 (1.17-1.70)	1.82 (1.53-2.22)	2.47 (2.06-3.00)	2.97 (2.47-3.59)	3.65 (2.98-4.39)	4.17 (3.36-4.99)	4.70 (3.72-5.62)	5.25 (4.06-6.26)	5.98 (4.53-7.14)	6.53 (4.85-7.81)
30-min	0.936 (0.786-1.14)	1.22 (1.03-1.49)	1.66 (1.39-2.02)	2.00 (1.66-2.42)	2.46 (2.01-2.96)	2.81 (2.26-3.36)	3.17 (2.51-3.78)	3.53 (2.75-4.21)	4.02 (3.05-4.81)	4.40 (3.26-5.26)
60-min	0.579 (0.486-0.707)	0.757 (0.638-0.925)	1.03 (0.860-1.25)	1.24 (1.03-1.50)	1.52 (1.24-1.83)	1.74 (1.40-2.08)	1.96 (1.55-2.34)	2.19 (1.70-2.61)	2.49 (1.89-2.97)	2.72 (2.02-3.26)
2-hr	0.336 (0.286-0.402)	0.436 (0.370-0.522)	0.582 (0.494-0.694)	0.694 (0.582-0.826)	0.848 (0.704-1.00)	0.966 (0.790-1.14)	1.09 (0.876-1.28)	1.21 (0.957-1.42)	1.38 (1.06-1.62)	1.50 (1.14-1.78)
3-hr	0.244 (0.207-0.295)	0.313 (0.267-0.380)	0.412 (0.348-0.496)	0.490 (0.410-0.587)	0.599 (0.494-0.713)	0.685 (0.558-0.814)	0.776 (0.620-0.921)	0.871 (0.684-1.03)	1.00 (0.763-1.19)	1.11 (0.823-1.32)
6-hr	0.148 (0.128-0.174)	0.187 (0.162-0.220)	0.240 (0.207-0.281)	0.282 (0.241-0.329)	0.339 (0.286-0.394)	0.384 (0.319-0.445)	0.431 (0.352-0.498)	0.478 (0.384-0.555)	0.543 (0.425-0.631)	0.595 (0.455-0.693)
12-hr	0.082 (0.072-0.095)	0.104 (0.090-0.121)	0.131 (0.114-0.152)	0.153 (0.132-0.177)	0.182 (0.156-0.210)	0.205 (0.173-0.236)	0.228 (0.189-0.263)	0.251 (0.206-0.290)	0.283 (0.226-0.328)	0.307 (0.241-0.359)
24-hr	0.049 (0.044-0.056)	0.063 (0.055-0.071)	0.081 (0.072-0.092)	0.096 (0.084-0.109)	0.116 (0.102-0.131)	0.132 (0.115-0.149)	0.149 (0.129-0.168)	0.166 (0.142-0.188)	0.190 (0.161-0.215)	0.209 (0.175-0.237)
2-day	0.027 (0.024-0.030)	0.034 (0.030-0.039)	0.045 (0.040-0.050)	0.053 (0.047-0.060)	0.065 (0.057-0.073)	0.074 (0.065-0.084)	0.084 (0.073-0.095)	0.095 (0.082-0.107)	0.109 (0.093-0.124)	0.121 (0.102-0.138)
3-day	0.019 (0.017-0.021)	0.024 (0.021-0.027)	0.032 (0.028-0.036)	0.038 (0.033-0.043)	0.046 (0.041-0.052)	0.053 (0.046-0.060)	0.061 (0.052-0.068)	0.068 (0.059-0.077)	0.079 (0.067-0.090)	0.088 (0.074-0.100)
4-day	0.015 (0.013-0.017)	0.019 (0.017-0.022)	0.025 (0.022-0.028)	0.030 (0.026-0.034)	0.037 (0.032-0.042)	0.043 (0.037-0.048)	0.049 (0.042-0.055)	0.055 (0.047-0.062)	0.064 (0.054-0.072)	0.071 (0.060-0.081)
7-day	0.009 (0.008-0.011)	0.012 (0.011-0.014)	0.016 (0.014-0.018)	0.019 (0.017-0.022)	0.024 (0.021-0.027)	0.027 (0.024-0.031)	0.031 (0.027-0.035)	0.035 (0.030-0.040)	0.041 (0.034-0.046)	0.045 (0.038-0.052)
10-day	0.007 (0.006-0.008)	0.009 (0.008-0.010)	0.012 (0.011-0.014)	0.015 (0.013-0.016)	0.018 (0.016-0.020)	0.021 (0.018-0.023)	0.023 (0.020-0.026)	0.026 (0.023-0.030)	0.031 (0.026-0.034)	0.034 (0.028-0.038)
20-day	0.004 (0.004-0.005)	0.006 (0.005-0.006)	0.008 (0.007-0.008)	0.009 (0.008-0.010)	0.011 (0.009-0.012)	0.012 (0.011-0.014)	0.014 (0.012-0.015)	0.015 (0.013-0.017)	0.017 (0.015-0.019)	0.019 (0.016-0.021)
30-day	0.003 (0.003-0.004)	0.004 (0.004-0.005)	0.006 (0.005-0.007)	0.007 (0.006-0.008)	0.008 (0.007-0.009)	0.009 (0.008-0.011)	0.011 (0.009-0.012)	0.012 (0.010-0.013)	0.013 (0.011-0.015)	0.015 (0.012-0.016)
45-day	0.003 (0.002-0.003)	0.003 (0.003-0.004)	0.005 (0.004-0.005)	0.005 (0.005-0.006)	0.006 (0.006-0.007)	0.007 (0.006-0.008)	0.008 (0.007-0.009)	0.009 (0.008-0.010)	0.010 (0.009-0.011)	0.011 (0.009-0.012)
60-day	0.002 (0.002-0.002)	0.003 (0.003-0.003)	0.004 (0.003-0.004)	0.004 (0.004-0.005)	0.005 (0.005-0.006)	0.006 (0.005-0.007)	0.007 (0.006-0.007)	0.007 (0.006-0.008)	0.008 (0.007-0.009)	0.009 (0.007-0.010)

<sup>1</sup> Precipitation frequency (PF) estimates in this table are based on frequency analysis of partial duration series (PDS). Numbers in parenthesis are PF estimates at lower and upper bounds of the 90% confidence interval. The probability that precipitation frequency estimates (for a given duration and average recurrence interval) will be greater than the upper bound (or less than the lower bound) is 5%. Estimates at upper bounds are not checked against probable maximum precipitation (PMP) estimates and may be higher than currently valid PMP values. Please refer to NOAA Atlas 14 document for more information.

[Back to Top](#)

### PF graphical

PDS-based intensity-duration-frequency (IDF) curves  
 Latitude: 33.5043°, Longitude: -111.9314°

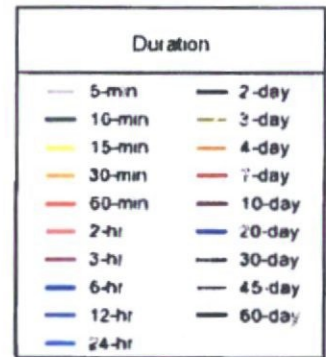
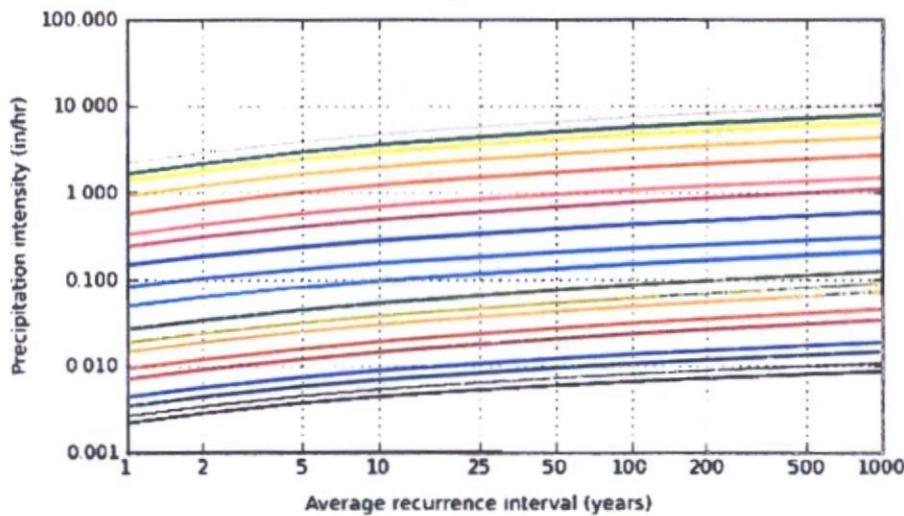
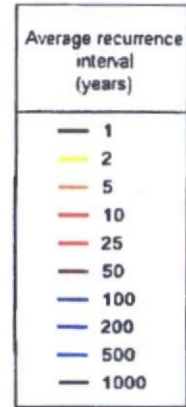
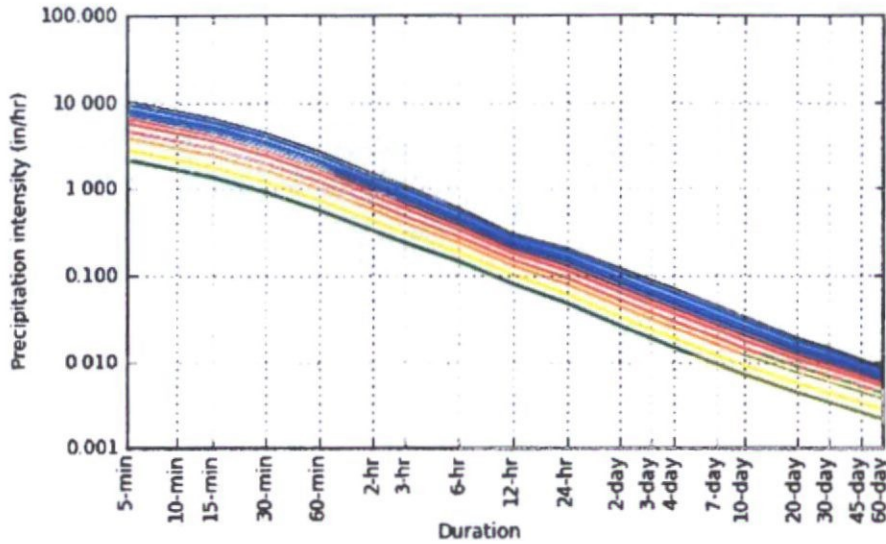

### Maps & aerals

Small scale terrain



Large scale terrain



Large scale map

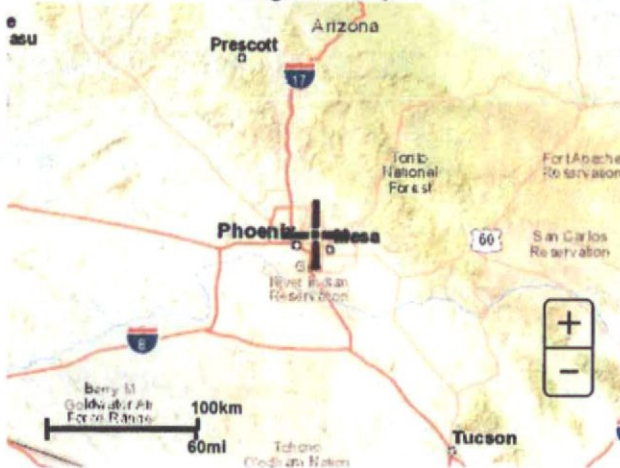

Large scale aerial



[Back to Top](#)

---

[US Department of Commerce](#)  
[National Oceanic and Atmospheric Administration](#)  
[National Weather Service](#)  
[National Water Center](#)  
1325 East West Highway  
Silver Spring, MD 20910  
Questions?: [HDSC.Questions@noaa.gov](mailto:HDSC.Questions@noaa.gov)

[Disclaimer](#)



# APPENDIX D SUPPLEMENTAL INFORMATION





**ARIZONA DEPARTMENT  
OF  
ENVIRONMENTAL QUALITY**



1110 West Washington Street Phoenix, Arizona 85007  
(602) 771-2300 [www.azdeq.gov](http://www.azdeq.gov)

**Notice of Intent (NOI) Certificate**

**LTF#: 69125**

**ID#:AZCN69125**

Type:**AZPDES Stormwater Construction General Permit (CGP)**

Issue Date:**12/07/2017**

Expiration Date:**06/02/2018**

**Coverage Issued to:**

Name:**KITCHELL CONTRACTORS INC OF ARIZONA**

Address Line 1:**1707 E HIGHLAND AVE**

City:**PHOENIX**

State:**AZ** zip : **85016**

**Construction Site Information:**

Name:**SFS LUX Renovation**

Latitude/Longitude:**33.505792 / -111.931869**

Acres Disturbed:**4.86**

Outfall Location(s):

**OUTFALL 1 | 33.505038 | -111.930568 | Arizona Canal-Granite Reef Dam -  
Cholla WTP**

Discharge Monitoring Report (DMR) Required:**No**

## **SWPPP Contact Information:**

First Name:**Cameron**

Last Name:**Flower**

Phone:**6023970821**

Work Email :**cflower@kitchell.com**

### **Main Office**

1110 W.Washington Street · Phoenix, AZ 85007  
(602)771-2300

### **Southern Regional Office**

400 W.Congress Street · Suite 433 · Tucson, AZ 85701  
(520)628-6733

[www.azdeq.gov](http://www.azdeq.gov)

E:\FORMWATER\COM\0508 VORTSENTRY HS\00 STANDARD DRAWINGS\HS\HS.DWG 5/16/2014 4:31 PM

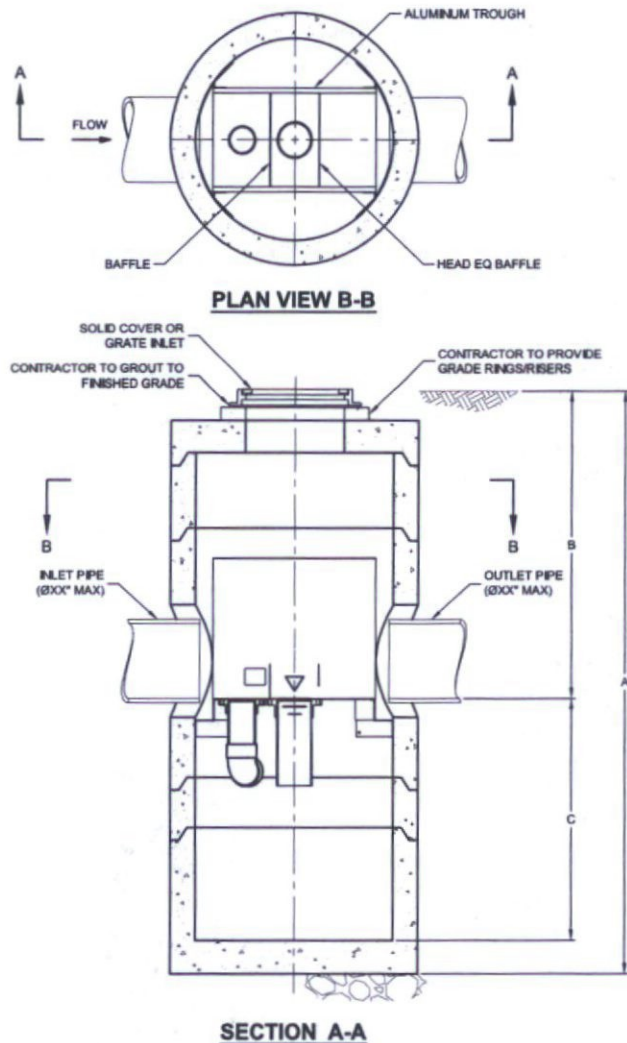

**VortSentry'**

THIS PRODUCT MAY BE PROTECTED BY ONE OR MORE OF THE FOLLOWING U.S. PATENTS & RELATED FOREIGN PATENTS OR PENDING APPLICATIONS:

**VORTSENTRY HS DESIGN NOTES**

VSHS RATED TREATMENT CAPACITY IS SHOWN IN THE TABLE BELOW, OR PER LOCAL REGULATIONS. MAXIMUM HYDRAULIC INTERNAL BYPASS CAPACITY VARIES. CONTACT YOUR CONTECH REPRESENTATIVE FOR ADDITIONAL INFORMATION.

THE STANDARD SOLID COVER CONFIGURATION IS SHOWN. ALTERNATE CONFIGURATIONS ARE AVAILABLE AND ARE LISTED BELOW.

**CONFIGURATION OPTION DESCRIPTION**

- GRATE INLET (NO INLET PIPE)
- GRATE INLET WITH INLET PIPE

**VORTSENTRY HS GENERAL INFORMATION**

Model	Manhole Diameter (ID)		Total Treatment Flow Rate		Typical Total Distance Rim to Outside Bottom A		Typical Distance Rim to Invert B		Typical Depth Below Invert (inside) C		Approximate Minimum Distance Rim to Invert		Maximum Pipe Diameter (ID)	
	FT	mm	CFS	L/S	FT	m	FT	m	FT	mm	FT	m	IN	mm
HS36	3	900	0.55	15.6	10.16	3.10	4.08	1.24	5.58	1702	3.00	0.91	18	450
HS48	4	1200	1.20	34.0	13.25	4.04	6.00	1.83	6.75	2057	4.00	1.22	24	600
HS60	5	1500	2.20	62.3	15.13	4.61	6.50	1.98	7.96	2426	4.82	1.47	30	750
HS72	6	1800	3.70	104.8	16.56	5.05	6.75	2.06	9.15	2788	5.59	1.70	36	900
HS84	7	2100	5.60	158.6	18.85	5.75	7.75	2.36	10.35	3156	5.00	1.52	42	1050
HS96	8	2400	8.10	229.4	20.87	6.36	8.50	2.59	11.54	3518	6.91	2.11	48	1200

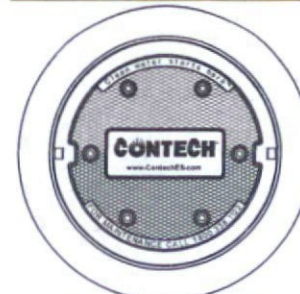

**FRAME AND COVER**  
(DIAMETER VARIES)  
N.T.S.

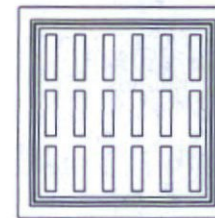

**FRAME AND GRATE**  
(24" SQUARE)  
N.T.S.

**SITE SPECIFIC DATA REQUIREMENTS**

STRUCTURE ID			
WATER QUALITY FLOW RATE (CFS)			*
PEAK FLOW RATE (CFS)			*
RETURN PERIOD OF PEAK FLOW (YRS)			*
PIPE DATA:	I.E.	MATERIAL	DIAMETER
INLET PIPE 1	*	*	*
OUTLET PIPE	*	*	*
RIM ELEVATION			*
ANTIFLOTATION BALLAST	WIDTH	HEIGHT	
	*	*	
NOTES/SPECIAL REQUIREMENTS:			
* PER ENGINEER OF RECORD			

**GENERAL NOTES**

- CONTECH TO PROVIDE ALL MATERIALS UNLESS NOTED OTHERWISE.
- DIMENSIONS MARKED WITH ( ) ARE REFERENCE DIMENSIONS. ACTUAL DIMENSIONS MAY VARY.
- FOR FABRICATION DRAWINGS WITH DETAILED STRUCTURE DIMENSIONS AND WEIGHT, PLEASE CONTACT YOUR CONTECH ENGINEERED SOLUTIONS LLC REPRESENTATIVE. [www.ContechES.com](http://www.ContechES.com)
- VORTSENTRY HS WATER QUALITY STRUCTURE SHALL BE IN ACCORDANCE WITH ALL DESIGN DATA AND INFORMATION CONTAINED IN THIS DRAWING.
- STRUCTURE SHALL MEET AASHTO HS20 AND CASTINGS SHALL MEET AASHTO M306 LOAD RATING, ASSUMING GROUNDWATER ELEVATION AT, OR BELOW, THE OUTLET PIPE INVERT ELEVATION. ENGINEER OF RECORD TO CONFIRM ACTUAL GROUNDWATER ELEVATION.

**INSTALLATION NOTES**

- ANY SUB-BASE, BACKFILL DEPTH, AND/OR ANTI-FLOTATION PROVISIONS ARE SITE-SPECIFIC DESIGN CONSIDERATIONS AND SHALL BE SPECIFIED BY ENGINEER OF RECORD.
- CONTRACTOR TO PROVIDE EQUIPMENT WITH SUFFICIENT LIFTING AND REACH CAPACITY TO LIFT AND SET THE VORTSENTRY HS MANHOLE STRUCTURE (LIFTING CLUTCHES PROVIDED).
- CONTRACTOR TO INSTALL JOINT SEALANT BETWEEN ALL STRUCTURE SECTIONS AND ASSEMBLE STRUCTURE.
- CONTRACTOR TO PROVIDE, INSTALL, AND GROUT PIPES. MATCH PIPE INVERTS WITH ELEVATIONS SHOWN.
- CONTRACTOR TO TAKE APPROPRIATE MEASURES TO ASSURE UNIT IS WATER TIGHT, HOLDING WATER TO FLOWLINE INVERT MINIMUM. IT IS SUGGESTED THAT ALL JOINTS BELOW PIPE INVERTS ARE GROUTED.



[www.ContechES.com](http://www.ContechES.com)  
8025 Centre Pointe Dr., Suite 400, West Chester, OH 45069  
800-338-1122 513-645-7000 513-645-7993 FAX

**VORTSENTRY HS  
STANDARD DETAIL**



URBANGREEN® 

**VortSentry® HS Guide  
Operation, Design,  
Performance and Maintenance**

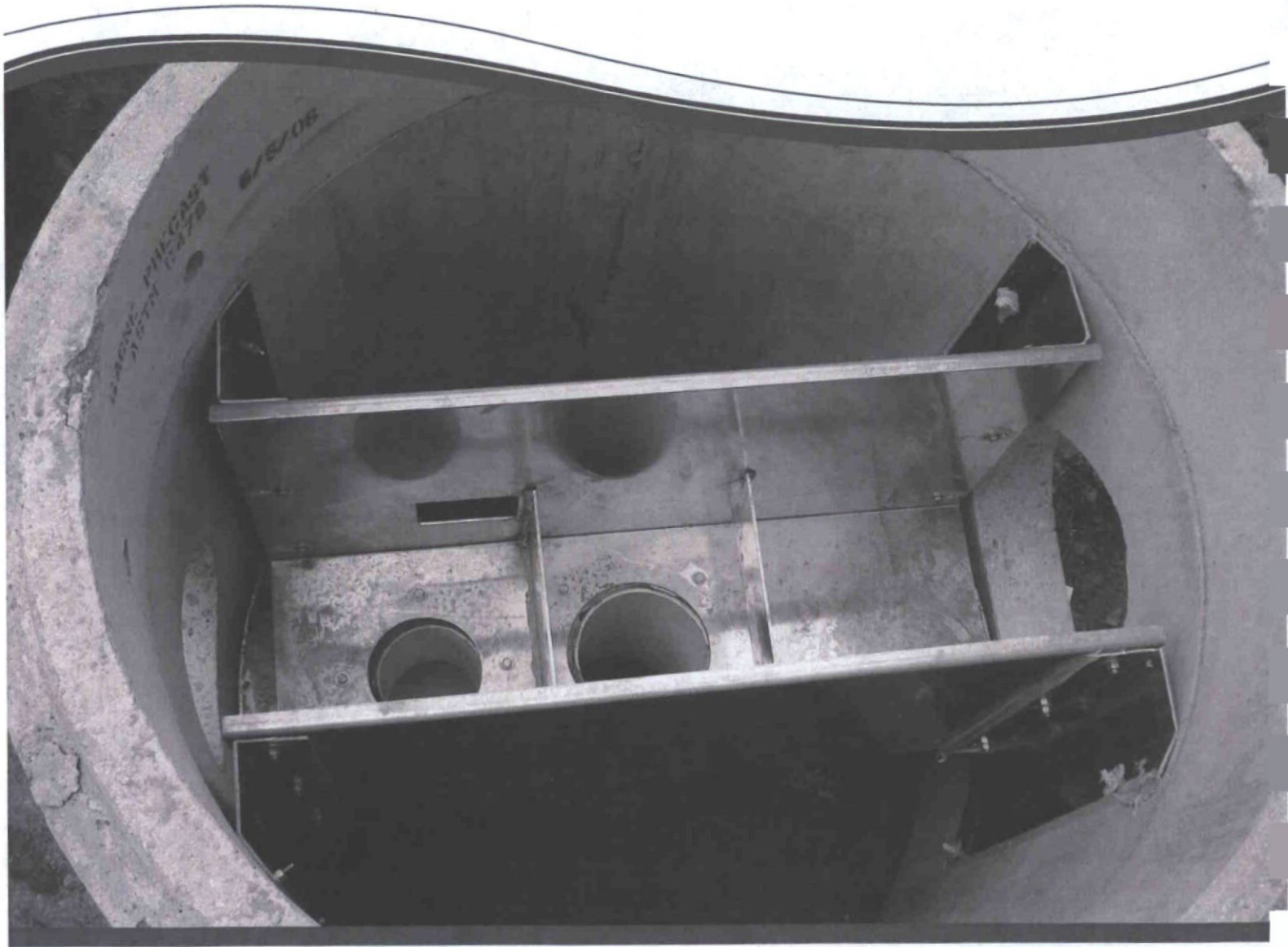

**CONTECH®**  
ENGINEERED SOLUTIONS

## VortSentry® HS

The VortSentry HS is a compact, below grade stormwater treatment system that employs helical flow technology to enhance gravitational separation of floating and settling pollutants from stormwater flows. With the ability to accept a wide range of pipe sizes, the VortSentry HS can treat and convey flows from small to large sites. A unique internal bypass design means higher flows can be diverted without the use of external bypass structures. The VortSentry HS is also available in a grate inlet configuration, which is ideal for retrofit installations.

### Operation Overview

Low, frequently occurring storm flows are directed into the treatment chamber through the primary inlet. The tangentially oriented downward pipe induces a swirling motion in the treatment chamber that increases capture and containment abilities. Moderate storm flows are directed into the treatment chamber through the secondary inlet, which allows for capture of floating trash and debris. The secondary inlet also provides for treatment of higher flows without significantly increasing the velocity or turbulence in the treatment chamber. This allows for a more quiescent separation environment. Settleable solids and floating pollutants are captured and contained in the treatment chamber.

Flow exits the treatment chamber through the outlet flow control, which manages the amount of flow that is treated and helps maintain the helical flow patterns developed within the treatment chamber.

Flows exceeding the system's rated treatment flow are diverted away from the treatment chamber by the flow partition. Internal diversion of high flows eliminates the need for external bypass structures. During bypass, the head equalizing baffle applies head on the outlet flow control to limit the flow through the treatment chamber. This helps prevent re-suspension of previously captured pollutants.

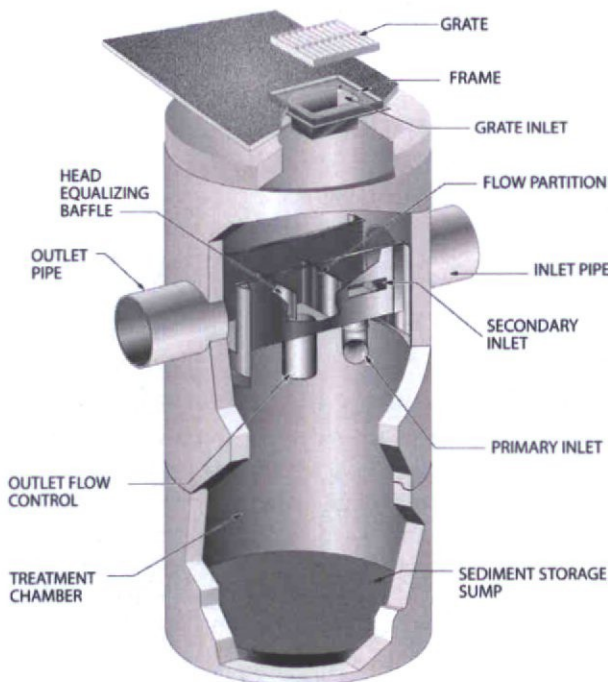

## Design Basics

There are two primary methods of sizing a VortSentry HS system. The Water Quality Flow Rate Method determines which model size provides the desired removal efficiency at a given flow for a defined particle size. The summation process of the Rational Rainfall Method is used when a specific removal efficiency of the net annual sediment load is required.

Typically, VortSentry HS systems are designed to achieve an 80% annual solids load reduction based on lab generated performance curves for a particle gradation with an average particle size ( $d_{50}$ ) of 240-microns ( $\mu\text{m}$ ).

### Water Quality Flow Rate Method

In many cases, regulations require that a specific flow rate, often referred to as the water quality design flow (WQQ), be treated. This WQQ represents the peak flow rate from either an event with a specific recurrence interval (i.e. the six-month storm) or a water quality depth (i.e. 1/2-inch of rainfall).

The VortSentry HS is designed to treat all flows up to the WQQ. Due to its internal bypass weir configuration, flow rates in the treatment chamber only increase minimally once the WQQ is surpassed. At influent rates higher than the WQQ, the flow partition will allow most flow exceeding the treatment flow rate to bypass the treatment chamber. This allows removal efficiency to remain relatively constant in the treatment chamber and reduces the risk of washout during bypass flows regardless of influent flow rates.

Treatment flow rates are defined as the rate at which the VortSentry HS will remove a specific gradation of sediment at a specific removal efficiency. Therefore they are variable based on the gradation and removal efficiency specified by the design engineer and the unit size is scaled according to the project goal.

### Rational Rainfall Method™

Differences in local climate, topography and scale make every site hydraulically unique. The Rational Rainfall Method is a sizing program Contech uses to estimate a net annual sediment load reduction for a particular VortSentry HS model based on site size, site runoff coefficient, regional rainfall intensity distribution, and anticipated pollutant characteristics. For more information on the Rational Rainfall Method, see *Vortechs Technical Bulletin 4: Modeling Long Term Load Reduction: The Rational Rainfall Method*, available at [www.ContechES.com/stormwater](http://www.ContechES.com/stormwater)

### Treatment Flow Rate

The outlet flow control is sized to allow the WQQ to pass entirely through the treatment chamber at a water surface elevation equal to the crest of the flow partition. The head equalizing baffle applies head on the outlet flow control to limit the flow through the treatment chamber when bypass occurs, thus helping to prevent re-suspension or re-entrainment of previously captured particles.

### Hydraulic Capacity

The VortSentry HS is available in three standard configurations: inline (with inlet and outlet pipes at 180° to each other), grated inlet, and a combination of grate and pipe inlets. All three configurations are available in 36-inch (900-mm) through 96-inch (2400-mm) diameter manholes.

The configuration of the system is determined by the suffix of the model name:

- A model name without a suffix denotes a standard pipe inlet (Example HS48).
- A "G" at the end of the model designation denotes a grate inlet (Example HS48G).
- A "GP" at the end of the model designation denotes a combination of grate and pipe inlets (Example HS48GP).

## Performance

### Full-Scale Laboratory Test Results

Laboratory testing of the VortSentry HS was conducted using F-55 Silica, a commercially available sand product with an average particle size of 240- $\mu\text{m}$  (Table 1). This material was metered into a model HS48 VortSentry HS at an average concentration of between 250-mg/L and 300-mg/L at flow rates ranging from 0.50-cfs to 1.5-cfs (14-L/s to 56-L/s).

US Standard Sieve Size	Particle Size Micron ( $\mu\text{m}$ )	Cumulative Passing %
30	600	99.7%
40	425	95.7%
50	300	74.7%
70	212	33.7%
100	150	6.7%
140	106	0.7%

Table 1 : US Silica F-55 Particle Size Distribution

Removal efficiencies at each flow rate were calculated based on net sediment loads passing the influent and effluent sampling points. Results are illustrated in Figure 1.

Assuming that sediment in the inlet chamber is ideally mixed, removal rates through the system will decay according to the percentage of flow bypassed. This effect has been observed in the laboratory where the test system is designed to produce a

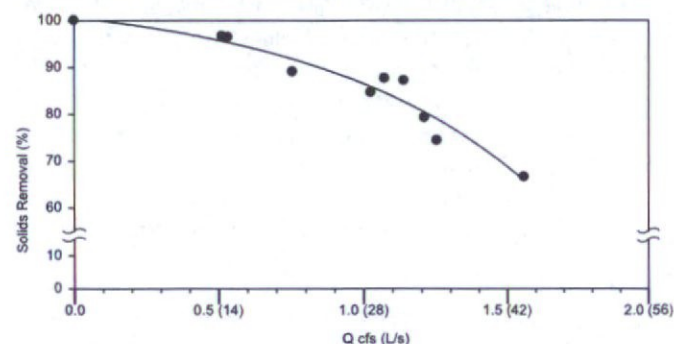

Figure 1: VortSentry HS Removal Efficiencies for 240- $\mu\text{m}$  Particle Gradation

thoroughly mixed inlet stream. All VortSentry HS models have the same aspect ratio regardless of system diameter (i.e. an increase in diameter results in a corresponding increase in depth). Operating rates are expressed volumetrically.

Removal efficiency at each operating rate is calculated according to the average of volumetric and Froude scaling methods and is described by Equation 1.

$$\text{Equation 1: } \left( \frac{\text{Diameter Prototype}}{\text{Diameter Model}} \right)^{2.75} = \left( \frac{\text{Flow Rate Prototype}}{\text{Flow Rate Model}} \right)$$

Equation 1 and actual laboratory test results were used to determine the flow rate which would be required for the various VortSentry HS models to remove 80% of solids.

View report at [www.ContechES.com/stormwater](http://www.ContechES.com/stormwater)

## Maintenance

The VortSentry HS system should be inspected at regular intervals and maintained when necessary to ensure optimum performance. The rate at which the system collects pollutants will depend more heavily on site activities than the size of the unit, i.e., unstable soils or heavy winter sanding will cause the treatment chamber to fill more quickly, but regular sweeping will slow accumulation.

## Inspection

Inspection is the key to effective maintenance and is easily performed. Pollutant deposition and transport may vary from year to year and regular inspections will help ensure that the system is cleaned out at the appropriate time. At a minimum, inspections should be performed twice per year (i.e. spring and fall) however more frequent inspections may be necessary in equipment washdown areas and in climates where winter sanding operations may lead to rapid accumulations of a large volume of sediment. It is useful and often required as part of a permit to keep a record of each inspection. A simple inspection and maintenance log form for doing so is available for download at [www.ContechES.com/stormwater](http://www.ContechES.com/stormwater)

The VortSentry HS should be cleaned when the sediment has accumulated to a depth of two feet in the treatment chamber. This determination can be made by taking two measurements with a stadia rod or similar measuring device; one measurement from the manhole opening to the top of the sediment pile and the other from the manhole opening to the water surface. If the difference between these measurements is less than the distance given in Table 2, the VortSentry HS should be maintained to ensure effective treatment.

## Cleaning

Cleaning of the VortSentry HS should be done during dry weather conditions when no flow is entering the system. Cleanout of the VortSentry HS with a vacuum truck is generally the most effective and convenient method of excavating pollutants from the system. Simply remove the manhole cover and insert the vacuum hose into the sump. All pollutants can be removed from this one access point from the surface with no requirements for Confined Space Entry.

In installations where the risk of petroleum spills is small, liquid contaminants may not accumulate as quickly as sediment. However, an oil or gasoline spill should be cleaned out immediately. Motor oil and other hydrocarbons that accumulate on a more routine basis should be removed when an appreciable layer has been captured. To remove these pollutants, it may be preferable to use adsorbent pads, which solidify the oils. These are usually much easier to remove from the unit individually, and less expensive to dispose than the oil/water emulsion that may be

created by vacuuming the oily layer. Floating trash can be netted out if you wish to separate it from the other pollutants.

Manhole covers should be securely seated following cleaning activities to prevent leakage of runoff into the system from above and also to ensure proper safety precautions. If anyone physically enters the unit, Confined Space Entry procedures need to be followed.

Disposal of all material removed from the VortSentry HS should be done in accordance with local regulations. In many locations, disposal of evacuated sediments may be handled in the same manner as disposal of sediments removed from catch basins or deep sump manholes. Check your local regulations for specific requirements on disposal.

VortSentry HS Model	Diameter		Distance		Sediment Storage		Oil Spill Storage	
			Between Water Surface and Top of Storage Sump					
	in.	m	ft.	m	yd <sup>3</sup>	m <sup>3</sup>	gal.	liter
HS36	36	0.9	3.6	1.1	0.5	0.4	83	314
HS48	48	1.2	4.7	1.4	0.9	0.7	158	598
HS60	60	1.5	6.0	1.8	1.5	1.1	258	978
HS72	72	1.8	7.1	2.2	2.1	1.6	372	1409
HS84	84	2.1	8.4	2.6	2.9	2.2	649	2458
HS96	96	2.4	9.5	2.9	3.7	2.8	845	3199

Note: To avoid underestimating the volume of sediment in the chamber, the measuring device must be carefully lowered to the top of the sediment pile. Finer, silty particles at the top of the pile may be more difficult to feel with the measuring stick. These finer particles typically offer less resistance to the end of the rod than larger particles toward the bottom of the pile.

Table 2: VortSentry HS Maintenance Indicators and Sediment Storage Capacities.

Logon to [www.ContechES.com/stormwater](http://www.ContechES.com/stormwater) to download the VortSentry HS Inspection and Maintenance Log.

For assistance with maintaining your VortSentry HS, contact us regarding the Contech Maintenance compliance certification program.



## CONTECH<sup>®</sup> ENGINEERED SOLUTIONS

©2014 CONTECH ENGINEERED SOLUTIONS, LLC.  
800-338-1122  
[www.ContechES.com](http://www.ContechES.com)

All Rights Reserved. Printed in the USA.

Contech Engineered Solutions LLC provides site solutions for the civil engineering industry. Contech's portfolio includes bridges, drainage, sanitary sewer, stormwater and earth stabilization products. For information on other Contech division offerings, visit [ContechES.com](http://ContechES.com) or call 800.338.1122

The product(s) described may be protected by one or more of the following US patents: 5,322,629; 5,624,576; 5,707,527; 5,759,415; 5,788,848; 5,985,157; 6,027,639; 6,350,374; 6,406,218; 6,641,720; 6,511,595; 6,649,048; 6,991,114; 6,998,038; 7,186,058; 7,296,692; 7,297,266; related foreign patents or other patents pending.

The Stormwater Management StormFilter, MFS and CDS are trademarks, registered trademarks, or licensed trademarks of Contech Engineered Solutions LLC. LEED is a registered trademark of the U.S. Green Building Council.

### Support

- Drawings and specifications are available at [contechstormwater.com](http://contechstormwater.com).
- Site-specific design support is available from our engineers.

NOTHING IN THIS CATALOG SHOULD BE CONSTRUED AS AN EXPRESSED WARRANTY OR AN IMPLIED WARRANTY OF MERCHANTABILITY OR FITNESS FOR ANY PARTICULAR PURPOSE. SEE THE CONTECH STANDARD CONDITIONS OF SALE (VIEWABLE AT [WWW.CONTECHES.COM/COS](http://WWW.CONTECHES.COM/COS)) FOR MORE INFORMATION.

**SCOTTSDALE FASHION SQUARE**  
**PHASE 10**

**PRELIMINARY GRADING AND DRAINAGE REPORT**

PREPARED FOR:

**WESTCOR**  
1411 North Tatum Boulevard  
Phoenix, Arizona 85028  
(602) 953-6379

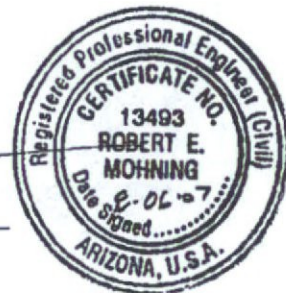

  
Robert E. Mohning, P.E., R.L.S.

August 7, 2007

**RICK ENGINEERING COMPANY**  
6150 North 16<sup>TH</sup> Street  
Phoenix, Arizona 85016-1705

**JOB NUMBER 3750**

## TABLE OF CONTENTS

1.0	INTRODUCTION .....	1
2.0	EXISTING DRAINAGE CONDITIONS AND CHARACTERISTICS .....	1
3.0	PROVIDED DRAINAGE PLAN .....	1
4.0	SPECIAL CONDITIONS .....	1
5.0	CONCLUSIONS.....	2

APPENDIX A        VICINITY MAP

APPENDIX B        FEMA FLOOD INSURANCE RATE MAP

APPENDIX C        MASTER DRAINAGE PLAN FOR SCOTTSDALE FASHION SQUARE

MAP POCKET 1      AERIAL PHOTOGRAPH OF AREA AND SITE

MAP POCKET 2      PRELIMINARY GRADING AND DRAINAGE PLAN

## 1.0 INTRODUCTION

Scottsdale Fashion Square is located at the northwest corner of Scottsdale Road and Camelback Road. This preliminary drainage report addresses drainage for redevelopment of the easterly portion of Scottsdale Fashion Square bounded on the east by Scottsdale Road, on the south by Camelback Road, on the west by Goldwater Boulevard, and on the north by Highland Avenue, see vicinity map Appendix A

The total net area of this area within the four street rights of way is 35.33 acres. The purpose of this report is to discuss the existing and proposed onsite and offsite drainage for the redevelopment. The redevelopment will remove the former Robinson's-May store and adjoining parking structure, and add two new anchors, new retail and restaurant spaces, and underground parking.

## 2.0 EXISTING DRAINAGE CONDITIONS AND CHARACTERISTICS

The Scottsdale Fashion Square site is fully developed with the retail mall, restaurants, a Days Inn Motel, office, and parking structures, see aerial photograph, Map Pocket 1.

Onsite drainage flows are generally from northwest to southeast. Onsite flows are intercepted by onsite catch basins or perimeter catch basins and are discharged into an existing 84 inch storm drain in Camelback Road and an existing 42 inch storm drain in Scottsdale Road. These two storm drain pipes connect to a 144 inch storm drain which drains east to the Indian Bend Wash.

All but a small portion of the site lies within Flood Zone "X" (textured) according to map number 04013C1695H of the FEMA Flood Information Map, dated September 30, 2005. A small area at the southeast corner of the site is within Flood Zone "A" because of the ponding of offsite flows against The Arizona Canal. An office building is located in this area and its finish floor is above the depth of the ponding.

Offsite drainage is from northwest to southeast toward the Arizona Canal. The site is higher than the elevation of the ponding at The Arizona Canal as described above.

## 3.0 PROPOSED DRAINAGE PLAN

The drainage patterns of the redevelopment will be consistent with the existing drainage. No retention will be provided per the approved Master Drainage Plan for Scottsdale Fashion Square, Appendix C, and the site's location within the City of Scottsdale Downtown Infrastructure Master Plan Volume 3 Drainage Study. This study was prepared in December 1986 by Boyle Engineering Corporation and concludes that no detention/retention be provided for the downtown study area. The proposed redevelopment will not alter the amount of impervious area nor the volume or direction of storm water flows. See Preliminary Grading and Drainage Plan in Map Pocket 2.

## 4.0 SPECIAL CONDITIONS

There are no special site conditions or need for a 404 permit. A Storm Water Pollution Prevention Plan will be prepared

## 5.0 CONCLUSIONS

The proposed redevelopment will not alter the existing storm water drainage and is drainage study consistent with the City of Scottsdale Downtown Infrastructure Master Plan Volume 3 .

**APPENDIX A**

# County Parcels



## **APPENDIX B**

PANEL 1695H

**FIRM  
FLOOD INSURANCE RATE MAP  
MARICOPA COUNTY,  
ARIZONA  
AND INCORPORATED AREAS**

**PANEL 1695 OF 4350**

(SEE MAP INDEX FOR FIRM PANEL LAYOUT)

CONTAINS:

<u>COMMUNITY</u>	<u>NUMBER</u>	<u>PANEL</u>	<u>SUFFIX</u>
MARICOPA COUNTY	040037	1695	H
PARADISE VALLEY, TOWN OF	040049	1695	H
SCOTTSDALE, CITY OF	045012	1695	H

Notice to User: The Map Number shown below should be used when placing map orders; the Community Number shown above should be used on insurance applications for the subject community.



**MAP NUMBER  
04013C1695H  
MAP REVISED**

**SEPTEMBER 30, 2005**

Federal Emergency Management Agency

Unincorporated Areas

040037

MCDONALD DR

DU1340

DU1339

126

126

12

DU1341

TASVILLAS

PALO VERDE DR

SOLANO DR

STARLIGHT WAY

PROFILE BASELINE

SAN MIGUEL AVE

ZONE X

LUKE LN 1258

JACKRABBIT RD

PECOS

1256

ZONE AE

Marcopa County 1258

Unincorporated Areas

040037

MEDLOCK DR

BONTA DR

PASADENA AVE

PASADENA AVE

RANCHO VISTA DR

NORTH HEND DR

ZONE X

MARIPOSA DR

1250

PARADISE PKY

ZONE A

HIGHLAND AVE

1248

City of Scottsdale 045012

Indian Bend Wash Low-Flow Channel

1246

ZONE X

MINNEZONA AVE

ZONE X

ZONE X

ZONE AE

CAMELBACK RD

1242

SHOEMAN LN

14<sup>000m</sup> E

15<sup>000m</sup> E

JOINS PA

**APPENDIX C**

**MASTER DRAINAGE PLAN  
FOR  
SCOTTSDALE FASHION SQUARE  
C.W.W. No. 831114-21**

Prepared for:  
**THE WESTCOR COMPANY II, LIMITED PARTNERSHIP**  
11411 North Tatum Boulevard  
Phoenix, Arizona 85028

Prepared by:  
**COLLAR, WILLIAMS & WHITE ENGINEERING**  
2702 North 44th Street, Suite 205-B  
Phoenix, Arizona 85008

**RECEIVED  
MASTER PLANNING**

MAY 19 1988

BY FIRST REVIEW

April, 1986

Approved by City of Scottsdale, August 18, 1986  
Revised May 10, 1988



**COLLAR, WILLIAMS & WHITE ENGINEERING**

### Drainage System

Scottsdale Fashion Square is an existing 35.0 acre shopping center located at the northwest corner of Camelback Road and Scottsdale Road in the City of Scottsdale, Arizona.

New development will occur on this site in multiple phases. These phases will include the demolition of some existing buildings, renovations to existing buildings, new office and commercial building construction, construction of new underground and elevated parking levels, and construction of a new 'retail bridge' to connect Scottsdale Fashion Square to Camelview Plaza to the west. In addition, the proposed "West Couplet Roadway" alignment will be along the westerly boundary of the project.

Existing on-site surface drainage flows are, in general, from the northwest towards the south and east. All existing drainage flows are intercepted by existing on-site catch basins and discharged into an existing 84 inch diameter storm drain in Camelback Road and an existing 42 inch diameter storm drain in Scottsdale Road. These two storm drains connect at the intersection of Camelback and Scottsdale Roads and empty into an existing 144 inch diameter storm drain which conveys the water under the Arizona Canal and to the East towards Indian Bend Wash.

Existing building roof drainage is presently routed via vertical roof drain leader lines to either existing on-site underground storm drainage systems or is discharged at existing grade and directed through existing curbing to the adjacent asphalt paved surfaces, where it sheet flows to existing storm drain inlets bordering the site.

As a part of the remodeling/renovating of existing buildings, additional floors will be added to the buildings. As additional floors are constructed, the existing vertical roof drain leader lines will be extended to the new roof levels. Future roof drainage from all new and renovated buildings will be connected

to on-site underground storm drainage systems, and all on-grade discharges will be eliminated.

There are no existing on-site storm water retention/detention facilities presently provided, and the new site development and modifications will not necessitate new on-site storm water retention/detention facilities (See attached letter from the City of Scottsdale dated December 8, 1987). Since the site is essentially impervious at this time, and will remain so after the redevelopment, no additional drainage flows will be generated.

A field survey made by Collar, Williams & White Engineering, of the top of the existing west bank of the Arizona Canal, indicates the elevations along the top of the existing west bank presently vary from 1378.0 feet to 1375.4 feet between the canal crossing at Highland Avenue and 500 feet south of the intersection of Scottsdale and Camelback Roads. With one foot of freeboard required above the maximum top of existing canal bank elevations, all new first floor building elevations have been established at no less than 1379.0. All existing building elevations are above this elevation. Both Camelback Road and Scottsdale Road are lower than elevation 1379.0.

New site development and modifications have incorporated adequate design measures to assure that no overflow of the Arizona Canal from a 100 year flood event will inundate any existing or proposed on-site building.

In addition, the new development has made adequate provisions to prevent any storm water from a 100 year event, which would flood the intersection of Camelback Road and Scottsdale Road from entering any underground basement or lower parking level.

This assurance has been achieved by denying direct driveway access from Scottsdale Road or Camelback Road to the new underground parking levels, and by construction of walls around the office building at the southeast corner of the site to prevent flooding of the basement area.



December 8, 1987

Mr. William R. Kendall  
Collar, Williams and White Engineering  
2702 North 44th Street, Suite 100A  
Phoenix, Arizona 85008

Dear Mr. Kendall:

This letter is to notify you that the City of Scottsdale will not require Scottsdale Fashion Square redevelopment (104-Z-85 and 59-Z-87) to provide any new onsite retention or detention facilities.

It is our understanding that the existing onsite catch basin and storm drain network which conveys stormwater runoff to the underground storm sewers in Camelback and Scottsdale Roads, will remain intact. These guidelines conform to the master drainage report for Scottsdale Fashion Square, approved by the City on August 18, 1986.

Sincerely,

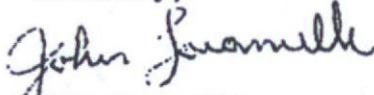
  
John Faramelli  
Project Review Director

cc: John Smetana, Project Review Manager  
Dick Crew, Planning and Zoning Manager  
Randy Grant, Project Review Manager

JF:sw

RECEIVED

DEC 15 1987

C.W.W. B.K.



# Warning and Disclaimer of Liability

The Drainage and Floodplain Regulations and Ordinances of the City of Scottsdale are intended to "minimize the occurrence of losses, hazards and conditions adversely affecting the public health, safety and general welfare which might result from flooding caused by surface runoff of rainfall" (Scottsdale Revised Code §37-16).

As defined in S.R.C. §37-17, a flood plain or "Special flood hazard area means an area having flood and/or flood related erosion hazards as shown on a FHBM or FIRM as zone AO, A1-30, AE, A99, AH, or E, and those areas identified as such by the floodplain administrator, delineated in accordance with subsection 37-18(b) and adopted by the floodplain board." It is possible that a property could be inundated by greater frequency events or by a flood greater in magnitude than a 100-year flood. Additionally, much of the Scottsdale area is a dynamic flood area; that is, the floodplains may shift from one location to another, over time, due to natural processes.

### WARNING AND DISCLAIMER OF LIABILITY PURSUANT TO S.R.C §37-22

"The degree of flood protection provided by the requirements in this article is considered reasonable for regulatory purposes and is based on scientific and engineering considerations. Floods larger than the base flood can and will occur on rare occasions. Floodwater heights may be increased by manmade or natural causes. This article (S.R.C. §37, Article II) shall not create liability on the part of the city, any officer or employee or the federal government for any flood damages that result from reliance on any administrative decision lawfully made thereunder."

Compliance with Drainage and Floodplain Regulations and Ordinances does not provide complete protection from flooding. The Floodplain Regulations and Ordinances establish established local and federal standards for floodplain management, but neither the Regulations and Ordinances take into account such flood related problems as erosion, streambed meander or man-made obstructions and diversions, all of which may have an adverse affect in the event of a flood. You are advised to consult your own engineer or other expert regarding these considerations.

I have read and understand the above. If I am an agent for an owner I have made the owner aware of and explained this disclaimer.

\_\_\_\_\_

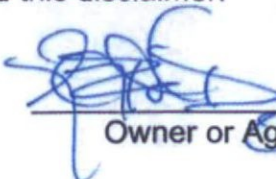
Plan Check No.  3/28/17

Owner or Agent Date