



Marked Agendas

Approved Minutes

Approved Reports

**The October 3, 2019
Development Review Board
Meeting Agenda and
Minutes can be found at**

<http://www.scottsdaleaz.gov/boards/development-review-board>

DEVELOPMENT REVIEW BOARD REPORT



Meeting Date: October 3, 2019 Item No. 4
General Plan Element: *Character and Design*
General Plan Goal: *Foster quality design that enhances Scottsdale as a unique southwestern desert community.*

ACTION

Spectrum - Camelback 8-DR-2019

Location: 8102 East Camelback Road

Request: Request approval of the site plan, landscape plan, and building elevations for a residential healthcare facility comprised of 2-story and 3-story-tall building with 111 beds in approximately 45,642 square feet of building area, all on a 4.5-acre site.

OWNER

Spectrum Acquisition Scottsdale, LLC

ARCHITECT/DESIGNER

Vessel Architecture & Design

ENGINEER

Sustainability Engineering Group

APPLICANT CONTACT

John Berry
Berry Riddell, LLC
(480) 385-2753

BACKGROUND

Zoning

The site is zoned Commercial Office (C-O) and Open Space (O-S), as established by zoning district map amendment Case 1-ZN-2018.

Context

The subject property is located east of the northeast corner of East Camelback Road and North Hayden Road. The previous use on the property was the Le Cordon Bleu College of Culinary Arts.

Adjacent Uses and Zoning

- North: Cameldale Unit One, residential subdivision; zoned Townhouse Residential district (R-4)
- South: Indian School Park; zoned Open Space district (O-S) and Scottsdale Sorrento Apartments; zoned Multiple-family Residential district (R-5)

- East: Scottsdale Country Acres, residential subdivision; zoned Single-family Residential district (R1-7)
- West: Indian Bend Wash; zoned Open Space district (O-S)

Key Items for Consideration

- Consistent with 1-ZN-2018, approved with conceptual site plan and elevations

DEVELOPMENT PROPOSAL

Goal/Purpose of Request

The development proposal includes a new 111-bed specialized residential health care facility, providing both assisted living and memory care services.

Neighborhood Communication

With the submittal of this application, the applicant and the City send out notification to property owners within 750 feet of this application. Staff received some inquiries as to the details of the project over the course of the review process but received no written comments regarding this application.

DEVELOPMENT REVIEW BOARD CRITERIA ANALYSIS

The proposed development is consistent with the conceptual site plan and elevations represented with the associated zoning district map amendment, Case 1-ZN-2018, which changed from Service Residential (S-R) to Commercial Office (C-O) zoning on the majority of the site, leaving the southwestern portion of the site as Open Space (O-S) zoning. The former use on the property was the Le Cordon Bleu College of Culinary Arts, and Scottsdale Culinary Institute prior. The existing 2-story buildings on the site have been removed in anticipation of this redevelopment proposal. The C-O zoning district is typically intended to provide for development of office and related uses adjacent to commercial and residential areas, and identifies Residential Health Care Facilities as an allowed land use with specified development standards to promote greater open space preservation and pedestrian connectivity with the surrounding areas. The site is located in the Southern Scottsdale Character Area, which designates the property as an area of Neighborhood Revitalization. These revitalization areas also promote greater community connectivity, encouragement of redevelopment and reinvestment, strengthening of community identity, and encouragement of quality construction and design.

Parking for the proposed use requires 78 spaces; 105 spaces are shown on the proposed site plan. Additionally, 8 of the spaces provided will be re-designated for use by the City at the southwest end of the site, by separate recorded agreement amending the previous such agreement on the site for park maintenance and overflow parking. The site plan proposes pedestrian access around the building with connections to a widened sidewalk along Camelback Road and then into the adjacent park system.

The site plan proposes to reconstruct the parking along the East Camelback Road frontage to create the required frontage open space landscape buffer between the parking and the street that did not previously exist on the property. The site design also accounts for the increased open space requirement specific to the Residential Health Care land use.

The development proposal utilizes a 2-story and-3-story building which divides the assisted living and memory care operational components into separately functioning components within the building. The layout also features an interior courtyard space accessible from the internal dining and common areas, branching off from the main lobby. The exterior building elevations utilize a combination of stucco and stone cladding with tile roofing which are accented by metal awnings and trim work.

Development Information

The development proposal includes a new 111-bed specialized residential health care facility. The facility proposed will provide both assisted living and memory care within a two-story and-three-story building on the subject site.

- Existing Use: Le Cordon Bleu College of Culinary Arts (vacant)
- Proposed Use: Residential Health Care Facility
- Buildings/Description: one building (2-and-3-story)
- Parcel Size: 4.5 acres (gross)
3.2 acres (net)
- Building Height Allowed: 48 feet (32 feet within 100 feet of a residential district)
- Building Height Proposed: 39 ½ feet (32 feet within 100 feet of a residential district)
- Parking Required: 78 spaces
- Parking Provided: 105 spaces
- Open Space Required: 33,867sqft (0.69ac)
- Open Space Provided: 38,758sqft (0.8ac)

STAFF RECOMMENDATION

Recommended Approach:

Staff recommends that the Development Review Board approve Spectrum Camelback per the attached stipulations, finding that the provisions of the Development Review Criteria have been met.

RESPONSIBLE DEPARTMENT

Planning and Development Services

Current Planning Services

STAFF CONTACT

Jeff Barnes
Senior Planner
480-312-2376
E-mail: jbarnes@ScottsdaleAZ.gov

APPROVED BY

Jeff Barnes, Report Author

Date

9/12/19

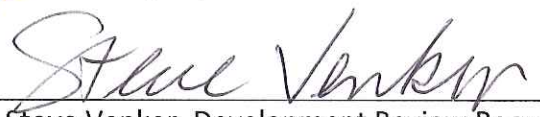
Steve Venker, Development Review Board Coordinator
Phone: 480-312-2831 E-mail: svenker@scottsdaleaz.gov

Date

9/16/19

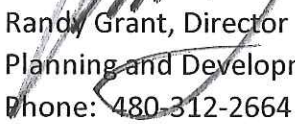
Randy Grant, Director
Planning and Development Services
Phone: 480-312-2664 E-mail: rgrant@scottsdaleaz.gov

Date

9/25/19

ATTACHMENTS

- A. Stipulations/Zoning Ordinance Requirements
 - 1. Context Aerial
 - 1A. Close-Up Aerial
 - 2. Zoning Map
 - 3. Applicant's Narrative
 - 4. Site Plan
 - 5. Open Space Plan
 - 6. Landscape Plan
 - 7. Building Elevations (color)
 - 8. Building Elevations (black & white)
 - 9. Material and Color Boards
 - 10. Electrical Site Plan
 - 11. Exterior Lighting Cutsheets

**Stipulations for the
Development Review Board Application:
Spectrum - Camelback
Case Number: 8-DR-2019**

These stipulations are intended to protect the public health, safety, welfare, and the City of Scottsdale.

APPLICABLE DOCUMENTS AND PLANS:

1. Except as required by the Scottsdale Revised Code (SRC), the Design Standards and Policies Manual (DSPM), and the other stipulations herein, the site design and construction shall substantially conform to the following documents:
 - a. Architectural elements, including dimensions, materials, form, color, and texture shall be constructed to be consistent with the building elevations submitted by Vessel Architecture & Design, with a city staff date of 8/12/19.
 - b. The location and configuration of all site improvements shall be consistent with the site plan submitted by Vessel Architecture & Design, with a city staff date of 8/12/19.
 - c. Landscape improvements, including quantity, size, and location shall be installed to be consistent with the preliminary landscape plan submitted by Kleski & Associates, with a city staff date of 8/12/19.
 - d. The case drainage report submitted by Sustainability Engineering Group and accepted in concept by the Stormwater Management Department of the Planning and Development Services.
 - e. The water and sewer basis of design report submitted by Sustainability Engineering Group and accepted in concept by the Water Resources Department.

RELEVANT CASES:

Ordinance

- A. At the time of review, the applicable Zoning case for the subject site was: 1-ZN-2018.

ARCHAEOLOGICAL RESOURCES:

Ordinance

- B. Any development on the property is subject to the requirements of Scottsdale Revised Code, Chapter 46, Article VI, Section 46-134 - Discoveries of archaeological resources during construction.

ARCHITECTURAL DESIGN:

DRB Stipulations

2. All exterior window glazing shall be recessed a minimum of fifty (50) percent of the wall depth, including glass windows within any tower/clerestory elements. The amount or recess shall be measured from the face of the exterior wall to the face of the glazing, exclusive of external detailing.

With the final plan submittal, the developer shall provide head, jamb and sill details clearly showing the amount of recess for all window types.

3. All exterior doors shall be recessed a minimum of thirty (30) percent of the wall depth, the amount of recess shall be measured from the face of the exterior wall to the face of the glazing, exclusive of external detailing. With the final plan submittal the developer shall provide head, jamb and sill details clearly showing the amount of recess for all door types.

SITE DESIGN:

DRB Stipulations

4. Prior to issuance of any building permit for the development project, the property owner shall submit plans and receive approval to construct all refuse enclosures in conformance with the City of Scottsdale Supplement to MAG Standard Details, detail 2146-1, 2 (2 is grease containment) for single enclosures, and #2147-1, 2 (2 is grease containment) for double enclosures. Screen wall shall be one foot higher than compactor.

EXTRIOR LIGHTING:

DRB Stipulations

5. All exterior luminaires shall meet all IES requirements for full cutoff, and shall be aimed downward and away from property line except for sign and landscape lighting.
6. Incorporate the following parking lot and site lighting into the project's design:
 - a. The maintained average horizontal luminance level, at grade on the site, shall not exceed 2 foot-candles. All exterior luminaires shall be included in this calculation.
 - b. The maintained maximum horizontal luminance level, at grade on the site, shall not exceed 8 foot-candles. All exterior luminaires shall be included in this calculation.
 - c. The initial vertical luminance at 6-foot above grade, along the entire property line shall not exceed 0.8 foot-candles. All exterior luminaires shall be included in this calculation.
 - d. The total lumen per luminaire shall not exceed 24,000 lumens.

STREET INFRASTRUCTURE:

DRB Stipulations

7. All street infrastructure improvements shall be constructed in accordance with this City of Scottsdale (COS) Supplement to MAG Specifications and Details, and the Design Standards and Policies Manual.
8. Prior to the issuance of any building permit for the development project, the property owner shall submit and obtain approval of civil construction documents to construct the following improvements:
 - a. East Camelback Road
 - i. Construct an 8-foot-wide sidewalk along East Camelback Road.
 - ii. Construct ADA ramps at the intersection of North 81st Street. All curb ramps for public and pedestrian sidewalks that intersect public and private streets, or driveways that intersect public and private streets, shall have truncated domes that are colored to match OSHA Safety Yellow, FED-STD-595C, 13591.

- iii. Remove the two existing driveways and construct one new driveway to line up with the existing driveway on the south side of East Camelback Road.
- b. North 81st Street.
 - i. Construct a 6-foot-wide sidewalk connection along the west side of North 81st Street, tying in to the neighboring subdivision to the north, northwest of the existing gatehouse.

WATER AND WASTEWATER:

DRB Stipulations

- 9. Prior to the civil construction document submittal, the property owner shall obtain approval of the master water and wastewater reports from the Water Resources Department. The civil construction document submittal shall be consistent with the approved master water and wastewater reports. Any design that modifies the approved master report requires from the owner a site-specific addendum to the master report, subject to review and approval by City staff.
- 10. Existing water and sewer service lines to this site shall be utilized, or shall be disconnected at the main pursuant to the Water Resources Department requirements.

DRAINAGE AND FLOOD CONTROL:

DRB Stipulations

- 11. With the civil construction document submittal, the property owner shall submit a final drainage report that demonstrates consistency with the DSPM and the case drainage report accepted in concept by the Stormwater Manager or designee, which must address the following:
 - a. The HEC-RAS model for Indian Bend Wash must be run for the FIS Q100 as well as for the USACE Q100 of 30,000 cfs. Both results must be discussed separately in the drainage report and the LF88 of the proposed buildings must be set to FRE (BFE + 1.0 foot) at a minimum based on the higher of the two Q100 (s).
 - b. The FIS digital HEC-RAS model for Indian Bend Wash has been provided to the Engineer to set up his "Effective HEC-RAS Model" for the project site. The Engineer must delete all unnecessary upstream and downstream River Stations from the model to set up and run the site-specific "Effective HEC-RAS Model". Then the Engineer needs to set up and run a "Modified Effective HEC-RAS Model" based on the site survey topography and a "Proposed HEC-RAS Model", if there are proposed improvements into the floodplain. All three (3) HEC-RAS models (or two models, if there isn't any proposed model) must be run for both the FIS Q100 as well as for the USACE Q100 of 30,000 cfs.
 - c. While it is understandable not to model the two 30-inch pipes under East Camelback Road in the HEC-RAS model, but modeling the 3-barrel existing box culvert under East Camelback Road in fact helps the Engineer with the RFE requirements. However, at the Engineer's discretion, he may model East Camelback Road in HEC-RAS as an "Inline Structure" (a weir) and may disregard the box culvert but, East Camelback Road cannot be modeled in HEC-RAS as regular River Stations.
 - d. The Manning's "n" values for the LOB, Main Channel, and the ROB seem very low (0.02, 0.025, 0.035, etc.). Even if the original HEC-2 and/or FIS HEC-RAS models may have used those Manning's "n" values, but such values can no longer be used in the current HEC-RAS model. The

entire wash along with the floodplain area appears to be grass-lined and therefore, a single Manning's "n" value of 0.045 appears to be more representative for the LOB, Main Channel, and the ROB according to the FCDMC Hydraulics Manual. Please reevaluate and modify the Manning's "n" values in the HEC-RAS model.

EASEMENTS DEDICATIONS:

DRB Stipulations

12. Prior to the issuance of any building permit for the development project, the property owner shall dedicate the following easements to the City of Scottsdale on a final plat or map of dedication:
 - a. A sight distance easement, in conformance with figures 5.3-26 and 5.3-27 of Section 5.3 of the DSPM, where a sight distance triangle(s) cross on to the property.
 - b. One-foot-wide Vehicular Non-Access Easement (VNAE) along the East Camelback Road frontage, except at the driveway location.
 - c. A continuous Public Non-Motorized Access Easement (PNMAE) to the City of Scottsdale to contain the public sidewalk in locations where the sidewalk crosses on to the lot.



Context Aerial

ATTACHMENT 1

8-DR-2019



Q.S.
18-47

Google Earth Pro Imagery



Aerial Close-Up

ATTACHMENT 1A

8-DR-2019

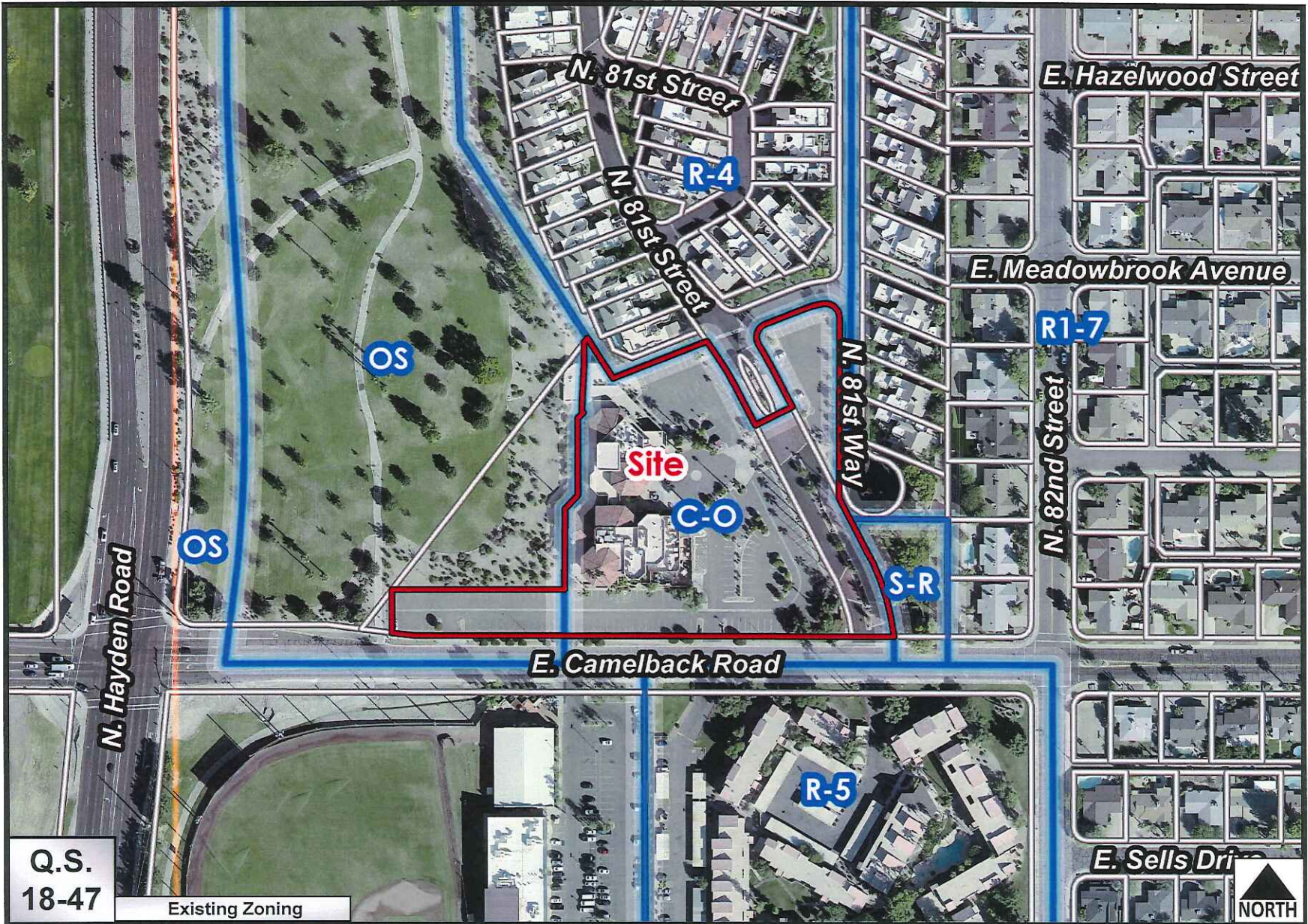

Q.S.
18-47

Existing Zoning

Zoning Map

ATTACHMENT 2

8-DR-2019

Spectrum/ Camelback Residential Health Care



DRB Project Narrative

8102 E. Camelback

January 17, 2019

Submitted by:

BERRY | RIDDELL
LLC

ATTACHMENT 3

PRINCIPALS AND DEVELOPMENT TEAM

DEVELOPER

Spectrum Retirement Communities
Michael Longfellow
200 Spruce Street, Suite 200
Denver, CO 80230
Tel: 303-218-0406

ENGINEER

SEG Sustainability Eng. Group
Ali Fakh, Owner/Engineer
Steve Counsell, Engineer
8280 E. Gelding Drive, Suite 101
Scottsdale, AZ 85260
Tel: 480-588-7226

ARCHITECT

Vessel Architecture & Design
Brian Van Winkle, Principal Architect
Kevin Gates, Architect
600 Emerson Road, Suite 401
St. Louis, MO 63141
Tel: 314-324-2542

OUTREACH

Technical Solutions
Susan Bitter Smith
Prescott Smith
4350 E. Camelback Road, Suite G-200
Phoenix, AZ 85018
602-957-3434

LAND USE ATTORNEY

Berry Riddell LLC
John Berry, Esq.
Michele Hammond, Principal Planner
6750 E Camelback Road, Suite 100
Scottsdale, Arizona 85251
Tel: 480-385-2727

PURPOSE AND INTENT

The request is for Development Review Board ("DRB") approval on a 4.5+/- acres site located at 8102 E. Camelback Road (the "Property") zoned Commercial Office (C-O) pursuant to approved zoning case 1-ZN-2018 (City Council approved 8/28/2018) for the development of a "residential health care" senior living community with both assisted living and memory care (both classified as "specialized care" per the Zoning Ordinance definition). Identified as Office in the City of Scottsdale (the "City") General Plan, the project is consistent with the land use designation, promotes land use balance, and will provide for the achievement of many of the City's long-term goals. The site is currently occupied by the Le Cordon Bleu College of Culinary Arts building, although the use vacated several years ago. The proposal includes a two- and three-story building with a central open space amenity and surface parking per City Code. Improvements along Camelback will include a refined sidewalk connection and increased open space buffer.

At this facility, Spectrum Retirement Communities will provide two senior living options; assisted living and memory care. The assisted living programs are designed to offer residents assistance with activities of daily living. Their professionally trained staff works closely with each family to determine which program is most appropriate, so residents get the best care possible. Memory care requires knowledge, experience, understanding and most importantly, compassion. The Spectrum memory care program is dedicated to providing an atmosphere that promotes independence, dignity, privacy and choice.



ABOUT SPECTRUM

Spectrum Retirement Communities currently operates in twelve states with several assisted living facilities in Arizona and others under development. Spectrum has established design principles that are highly sensitive to the surrounding communities and supportive of a safe, functional and comfortable living environment for its residents.

The Enclave at Anthem and Palo Verdes in Peoria depicted below



SITE CONDITIONS & LOCATION

This infill site is comprised of the underutilized, vacated Le Cordon Bleu College of Culinary Arts building, parking along south and east, and ingress/egress to the east which is shared with the existing Cameldale residential community to the north.

This Property is ideally situated among a variety of complementary uses and the plan incorporates sensitive design elements that will create appropriate transitions between the adjacent uses. This land use is a compatible fit with the surrounding context and will promote the character of the neighborhood, which consists of a blend of diverse uses existing in harmony with one another

Traditionally, senior living flourishes when surrounded by such synergistic uses as complementary commercial services, single-family residential and open space/recreational opportunities and this infill Property is ideally situated given the context. North of the site lies R-4 townhouse residential (Cameldale) and to the east, R1-7 single-family homes (Scottsdale Country Acres). To the south lies R-5 apartments and O-S (Club Sar and Giants facility), to the west is O-S (Indian Bend Wash). Nearby development includes a range of supportive businesses such as HonorHealth, medical offices, grocery, retail, and several restaurants. If desired, residents, employees and visitors can safely access the existing pathway system along Camelback without having to cross an arterial street.





DESIGN CONCEPT

Responding to the surrounding context, the proposed site design features purposeful walkways, a private internal courtyard, abundant landscaping, and building massing that respects the character of the adjacent uses. The building has been positioned with direct adjacency to the Indian Bend Wash open space amenity maximizing setbacks and landscaping along Camelback Road and the adjacent residential. Massing consists of two- and three-story elements. The dense native landscaping that wraps the Property provides both shade along the sidewalks for pedestrians and aesthetic interest, breaking up the horizontal lines of the building when viewed from adjacent homes and street frontages. The site plan includes parking predominately along the east and south sides, for residents, staff and visitors, under the shade of native trees.

The arrangement of the site is specifically designed for the benefit of residents and their mobility needs, but also promotes a synergistic land use pattern with the adjacent uses. The heights are tiered, to mimic the building character and heights of the adjacent development. Edge conditions are buffered by significant landscaping and provide a desert-lush setting for the building. Additionally, the stepped-up building massing creates an appropriate transitional buffer to the adjacent residential subdivision. Designed to complement the character and scale of the adjacent townhomes and single-family homes, this use creates a more suitable, quiet land use than the current culinary school which historically had significantly more traffic and noise.



The proposed assisted living community will allow residents to locate in an age-supportive environment while maintain close proximity to support services, family, and social circles. The ability to age in place while keeping one's lifestyle intact has become a key element in the quality of life and health for the senior population. Surrounded by neighborhoods, the incorporation of this use, in a way that blends into the overall character of the neighborhood, makes it easier for people to transition when needed, rather than being pushed out of the neighborhood because of lack of availability for senior lifestyle living with a range of assisted living care services on site.



A unique feature of this Property is its proximity to the Indian Bend Wash, and although many of these residents will not be actively using the Wash on a daily basis, it does afford opportunities for daily walks and social interaction for employees and visitors. Additionally, the building has been designed in a manner to take advantage of the open space view corridor with several units overlooking the Wash as well as a ground level seating/dining area along the Wash. The proposal will turn an underutilized Property into an appropriate land use that will bring additional business to nearby commercial and provide a much-needed service to the community in a manner that respects the scale of the existing context.

DEVELOPMENT PLAN

This proposal consists of a residential health care facility/assisted living with memory care with 111 beds (116 approved with zoning). The development provides seniors an opportunity to enjoy a vibrant, social and quality lifestyle while still providing minimal healthcare services (dining, transportation and wellness/medical, etc.).

Ingress/egress occurs from Camelback Road, a minor collector, via the main entrance that exists today with parking located east and south of the main building similar to the current onsite parking configuration for the old culinary school. By nature of the type of residency, senior living generates a much lower traffic count than traditional residential uses and the parking provided can be reduced without deleterious impacts on the neighborhood, visitors or residents. A traffic generation statement was provided with the approved zoning case. Vehicular access to the Property will incorporate indigenous landscape material and setbacks shield the use from adjacent properties.

Features of the design include an interior courtyards, sidewalks, outdoor shaded seating and group dining and resident gathering spaces. Amenities will be centrally located to increase accessibility for all residents and are designed and intended for the use of the residents and their guests. The inner courtyard provided a shaded refuge for residents and are easily accessible to all rooms.

The proposed senior living development will appeal to our aging demographic by providing a senior lifestyle with multiple support services such as central dining, transportation service and limited medical assistance including in an assisted living environment. While this facility is designed to be visually appealing, the design is functional in addressing the physical requirements and/or limitations of its elderly residents.

DEVELOPMENT REVIEW BOARD CRITERIA CONFORMANCE

In considering any application for development, the Development Review Board shall be guided by the following criteria (Sec. 1.904 A. of the Zoning Ordinance):

- 1. The Board shall examine the design and theme of the application for consistency with the design and character components of the applicable guidelines, development standards, Design Standards and Policies Manual, master plans, character plan and General Plan.*

Response: The Spectrum project will comply with the applicable guidelines, development standards, Design Standards & Policies Manual, SSCAP and General Plan. While the zoning narrative submitted under separate application speaks in more detail to the broader context of the General Plan and SSCAP, below is a summary of how this proposal complies.

The proposal is consistent with the General Plan Land Use Map designation, which identifies the Property as Office, as shown below. The proposal is supportive of the desired values defined in the General Plan, which include those goals for a community that "*facilitates human connection by anticipating and locating facilities that enable human communication and interaction*" and "*creates, revitalizes, and preserves neighborhoods that have long-term viability, unique attributes and character, livability, connectivity to other neighborhoods in the community, and that fit together to form an exceptional citywide quality of life*". The Spectrum community provides an opportunity for a compatible land use that increases options for seniors in this community, respects the character of the neighborhood and represents a vibrant, attractive development. The community vision is supported by this proposal, and the development will promote the achievement of many long-term goals outlined in the City's General Plan and SSCAP as the proposed development promotes revitalization and housing sustainability for the residents of Scottsdale.

The Property lies within the Southern Scottsdale Character Area Plan ("SSCAP"), which identifies this area as a community of residential neighborhoods with a need for people-oriented land uses, pedestrian-friendly design, dynamic streetscapes, gathering places, and building massing that complements the surrounding built environments. The proposed facility meets the need for a broader range of housing types in this area. The aging demographic is a rising population and the need for senior housing will increase as that group moves into the more dependent stages of life. The proposed development accomplishes a range of goals including the integration of high quality, vibrant architecture and innovative site planning, creating pedestrian presence with ground level activity, and providing needed housing for a growing demographic.

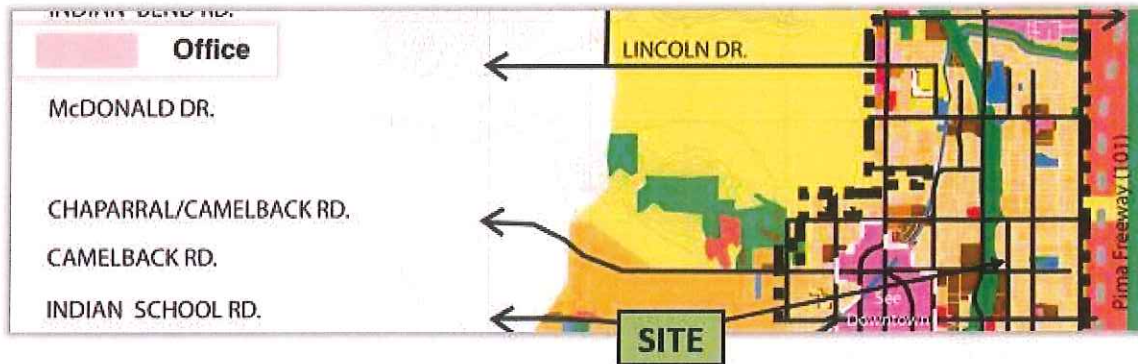

2. The architectural character, landscaping and site design of the proposed development shall:

a. Promote a desirable relationship of structures to one another, to open spaces and topography, both on the site and in the surrounding neighborhood;

Response: The Spectrum facility is a compatible development with the existing residential, mixed use, and public open space context. The building architecture has been carefully designed with a residential scale and appearance, which creates a welcoming environment for residents and supports consistency in neighborhood character. Generous open space has been incorporated into the design to respect the surrounding residential developments, preserve the residential scale and provide transitional buffers to separate the use. The proposal supports an appropriate land use pattern the neighborhood character through incorporation of streetscape amenities (curbs/sidewalks) as well as internal courtyards and sidewalks for residents and visitors.

b. Avoid excessive variety and monotonous repetition;

Response: The buildings have a modern Southwestern design with a variety of textures, colors and building finishes. The architectural elements provide solar shading and overhangs, and celebrate the Sonoran Desert setting by creating outdoor living spaces, recreational amenities and gathering spaces. The architectural design (as discussed in detail above) provides a thoughtful transition from surrounding established residential community. The two-story building element (over 50% of the building mass) is provided along the north and east transitioning from the existing residential. The three-story element is appropriately placed along the south and west closer to Camelback Road and the Indian Bend Wash.

c. Recognize the unique climatic and other environmental factors of this region to respond to the Sonoran Desert environment, as specified in the Sensitive Design Principles;

Response: Please see the Scottsdale Sensitive Design Principle Conformance section found in the following section.

d. Conform to the recommendations and guidelines in the Environmentally Sensitive Lands (ESL) Ordinance, in the ESL Overlay District; and

Response: Not applicable

e. Incorporate unique or characteristic architectural features, including building height, size, shape, color, texture, setback or architectural details, in the Historic Property Overlay District.

Response: Not applicable

3. Ingress, egress, internal traffic circulation, off-street parking facilities, loading and service areas and pedestrian ways shall be so designed as to promote safety and convenience.

Response: The primary vehicle entrance is via 81st Street from Camelback Road (existing point of access). The site plan includes parking predominately along the south and east sides, for residents, staff and visitors, under the shade of native trees. Pedestrian circulation is an important feature of this development along not only the perimeter and internal to the site, but also beyond from the Property to the nearby residential and commercial land uses. People will be encouraged to utilize the adjacent Indian Bend Wash for access to open space and nearby services. Employees and visitors can access the Property by alternate modes of transportation and the mixed-use component of the land use will encourage walkability.

4. If provided, mechanical equipment, appurtenances and utilities, and their associated screening shall be integral to the building design.

Response: All mechanical equipment, appurtenances and utilities will be full screened and/or incorporated in the building design.

5. Within the Downtown Area, building and site design shall...

Response: Not applicable.

6. The location of artwork provide in accordance with the Cultural Improvement Program or Public Art Program shall address the following criteria...

Response: Not applicable.



SCOTTSDALE'S SENSITIVE DESIGN PRINCIPLES

The Character and Design Element of the General Plan states that "Development should respect and enhance the unique climate, topography, vegetation and historical context of Scottsdale's Sonoran Desert environment, all of which are considered amenities that help sustain our community and its quality of life." The City has established a set of design principles, known as the Scottsdale's Sensitive Design Principles, to reinforce the quality of design in our community. The following Sensitive Design Principles are fundamental to the design and development of the Property.

- 1. The design character of any area should be enhanced and strengthened by new development.*

Response: The proposed development will utilize a variety of Sonoran Desert appropriate textures and building finishes, incorporate architectural elements that provide solar shading and overhangs, and celebrate the Southwestern climate by creating outdoor living spaces for each unit, recreational amenities, and gathering places for its residents.

Housing proportions here are respectful of the adjacent uses and building masses in tiered (2 and 3-story elements) to mimic the heights of the adjacent developments.

Landscape buffers and buildings orientation are designed to respect the adjacent single-family residences. The lowest intensity portion of the development is placed along the eastern side, to create an appropriate transition from one use to another. Final details to the character and design of the buildings will be determined through the DRB process.

2. Development, through appropriate siting and orientation of buildings, should recognize and preserve established major vistas, as well as protect natural features.

Response: The proposed landscape plan recognizes the visual significance and the important role mature landscaping plays in quality development. The landscape plan includes a broad range of desert appropriate trees, shrubs and ground cover to complement the surrounding environment and provide an enhanced visual setting for the new senior community. Spectrum has taken special consideration in providing meaningful open space and recreational amenities for the residents and visitors. Generous open space has been incorporated into the design to respect the surrounding residential developments, preserve the residential scale and provide transitional buffers creating an open space setting for the development. Well-shaded perimeter sidewalks and walking paths for residents and visitors are integrated throughout. Further, utilization of the trails contained within adjacent Indian Bend Wash is promoted by this proposal, which connects residents, employees and visitors to an opportunity for recreation, fitness and alternate modes of transportation. This nearby multi-use system of pathways will encourage the sense of community through its connection to the greater neighborhood.

3. Development should be sensitive to existing topography and landscaping.

Response: The site is developed with an existing office building and surface parking, and thus, is relatively flat from a topography standpoint. All landscaping will consist of low-water use desert appropriate landscaping materials. Respecting the Southwest's climate conditions, a variety of native materials and sizes will be integrated to create a layering effect to help mitigate the urban heat island effect.

4. Development should protect the character of the Sonoran Desert by preserving and restoring natural habitats and ecological processes.

Response: To the extent possible, the development will preserve and restore natural habitats and ecological processes through the inclusion of additional desert appropriate landscaping. New landscaping materials will contribute to the urban habitat for wildlife and improved air quality. Also, desert appropriate plants will be able to withstand the variations of the local climate and as they mature they should become self-sustaining relative to water demand. The plant variety for the proposed development is noted above.

5. ***The design of the public realm, including streetscapes, parks, plazas and civic amenities, is an opportunity to provide identity to the community and to convey its design expectations.***

Response: The street frontage of the Property incorporates design principles that respond to the pedestrian experience and provide safe and pleasant connections to the adjacent development. The design features a significant landscaping setback along Camelback, which will provide shade over the sidewalk and creates a buffer between the Spectrum community and minor collector street. In comparison, the current streetscape is characterized by minimal setbacks and landscaping with double-loaded parking.

6. ***Developments should integrate alternative modes of transportation, including bicycles and bus access, within the pedestrian network that encourage social contact and interaction within the community.***

Response: Sidewalk and pathways are integrated in and around the residential community. Doubling as a recreational and fitness opportunity, the scenic trails within the adjacent Indian Bend Wash also provide a valuable amenity to residents of the facility. The mixed-use nature of the Property provides services to nearby developments and encourage walkability.

7. ***Development should show consideration for the pedestrian by providing landscaping and shading elements as well as inviting access connections to adjacent developments.***

Response: The proposed development will incorporate design elements that respect human-scale, providing shade and shelter through building, site and landscape design. The site plan identifies the pedestrian circulation proposed with the application showing connectivity to/from/along the site. The landscaping of the site is intended to provide a desert-lush, pedestrian friendly environment to be enjoyed by the residents, visitors and employees.

8. ***Buildings should be designed with a logical hierarchy of masses.***

Response: As this Property is located adjacent to existing residential development to the north and east, distinctive design considerations create appropriate land use transitions from the medium density senior living facility to the adjacent homes. The primary building massing is located on the western edge of the Property, transitioning from 3 to 2-story elements with surface parking along the east.

9. ***The design of the built environment should respond to the desert environment.***

Response: The proposed development will utilize a variety of desert appropriate textures and building finishes, incorporate architectural elements that provide solar shading and

overhangs, and celebrate the Southwest climate by creating outdoor living spaces and amenities for its residents. Building materials and finishes will include stone, stucco, metal accents, metal shade canopies, tile roofing and insulated glazing.

10. *Developments should strive to incorporate sustainable and healthy building practices and products.*

Response: The pedestrian connectivity and recreational opportunities near the site are considered primary amenities for the residents and reduce vehicle trips. Sustainable strategies and building techniques, which minimize environmental impact and reduce energy consumption, will be emphasized. These sustainable building practices may include, but are not limited to, passive solar design, insulated glass, low-flow water fixtures, and energy efficient HVAC and appliances.

11. *Landscape design should respond to the desert environment by utilizing a variety of mature landscape materials indigenous to the arid region.*

Response: Context appropriate, mature arid-region plant materials will be utilized with the development of the Property. The desert character will be upheld through the careful selection of plant materials in terms of scale, density, and arrangement.

12. *Site design should incorporate techniques for efficient water use by providing desert adapted landscaping and preserving native plants.*

Response: The proposed development will maintain a low-water use plant palette and incorporate salvaged native plants (see landscape plan). Context appropriate desert plant materials will be utilized with the development of the Property, consistent with the established vegetative pattern along Camelback and throughout the Southern Scottsdale Character Area Plan.

13. *The extent and quality of lighting should be integrally designed as part of the built environment.*

Response: Lighting will be designed in a manner that is respectful of the surrounding context and will respect the City's dark sky policies with fully shielded fixtures, while maintaining safety for future residents and in conformance with City lighting standards. A lighting plan has been submitted with the DRB application.

14. *Signage should consider the distinctive qualities and character of the surrounding context in terms of size, color, location and illumination.*

Response: Project identification will be contextually appropriate and processed under a separate approval and permit process.

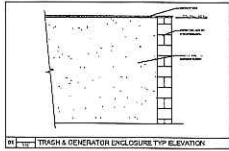

BENCHMARK:
 BENCHMARK IS A CITY OF SCOTTSDALE BRASS CAP FLUSH, LOCATED WEST OF THE INTERSECTION OF CAMELBACK ROAD AND HAYDEN ROAD. ELEVATION = 1244.70 NAVD 88.

BASIS OF BEARING:
 THE BASIS OF BEARING AND ALL MONUMENTATION SHOWN HEREON IS BASED ON THE SOUTH LINE OF THE NORTHWEST QUARTER OF SECTION 24, TOWNSHIP 2 NORTH, RANGE 4 EAST, USING A BEARING OF SOUTH 89 DEGREES 39 MINUTES 50 SECONDS EAST, AS SHOWN ON THE RECORD OF SURVEY RECORDED IN BOOK 1279, PAGE 39, MARICOPA COUNTY RECORDS.

Camelback Park

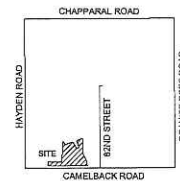
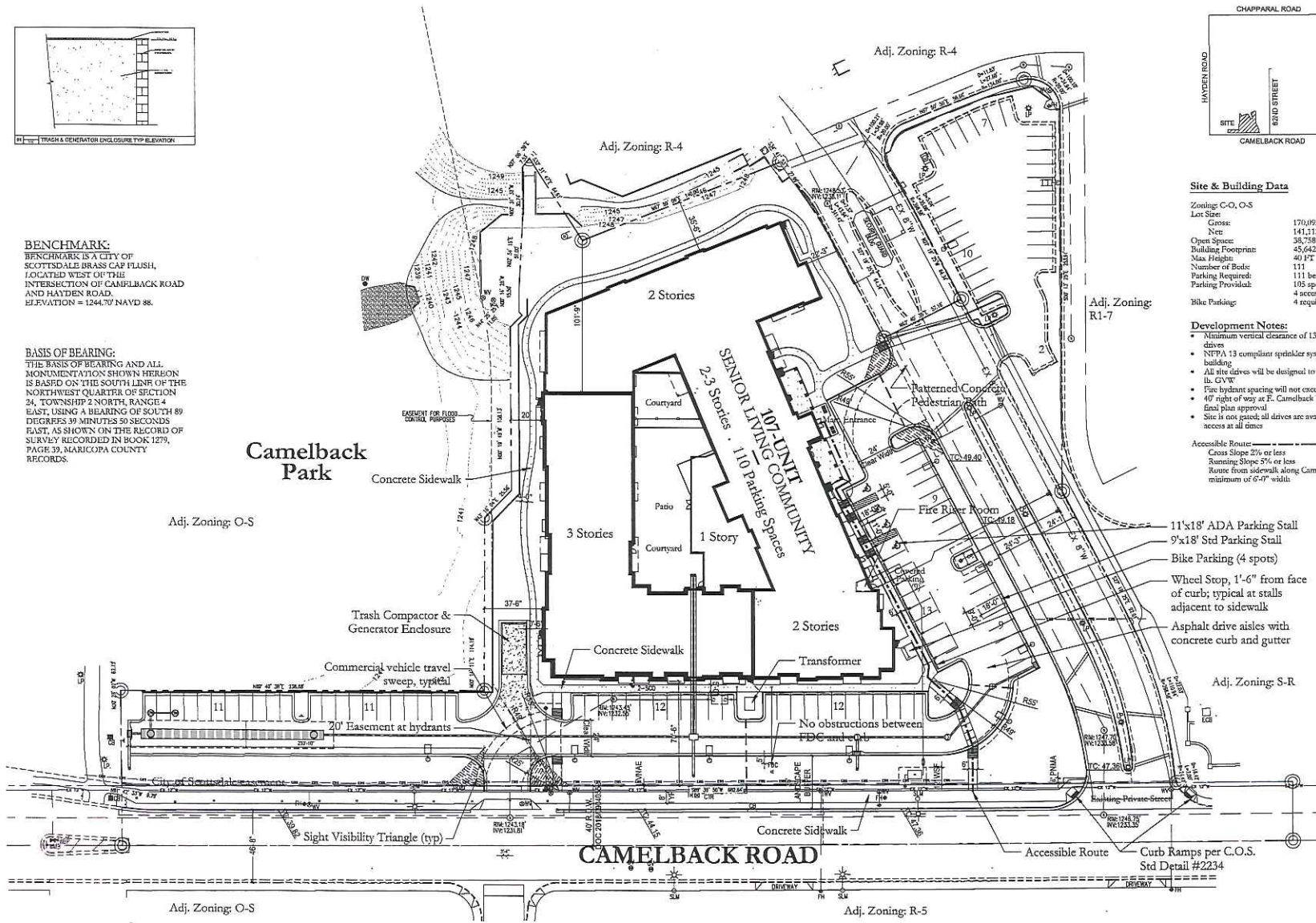

Site & Building Data

Zoning:	C-O, O-S
Lot Size:	Gross: 170,092 SF Net: 141,112 SF
Open Space:	38,708 SF
Building Footprint:	45,642 SF
Max Height:	111
Number of Units:	111
Parking Required:	111 beds * 0.7 = 78 spots required
Parking Provided:	105 spots provided
Bike Parking:	4 accessible, 4 required, 4 provided

Development Notes:

- Minimum vertical clearance of 13'-6" provided above all site drives
- NFPA 13 compliant sprinkler system to be used throughout building
- All site drives will be designed to support at minimum 83,000 lb. GVW
- Fire hydrant spacing will not exceed 700 ft on center.
- 40' right of way at E. Camelback Road to be dedicated with final plat approval
- Site is not gated; all drives are available for fire department access at all times

Accessible Routes:

- Cross Slope 2% or less
- Running Slope 5% or less
- Route from sidewalk along Camelback Rd to Front Door minimum of 6'-0" width

- 11'x18' ADA Parking Stall
- 9'x18' Std Parking Stall
- Bike Parking (4 spots)
- Wheel Stop, 1'-6" from face of curb; typical at stalls adjacent to sidewalk
- Asphalt drive aisles with concrete curb and gutter



SPECTRUM
 CAMELBACK ROAD
 #102 E Camelback Road
 Scottsdale, Arizona 85251

SITE PLAN

DR23

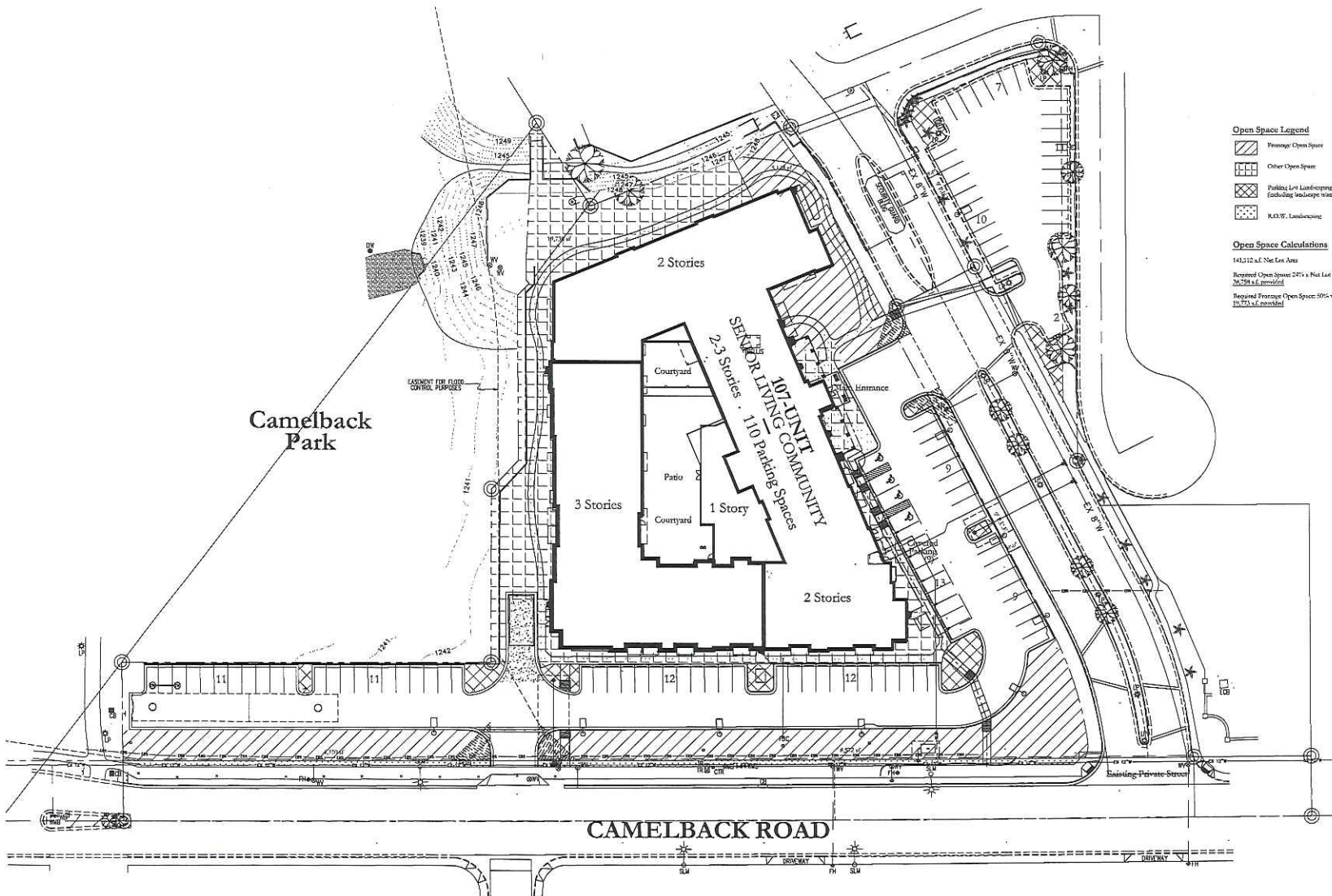

Open Space Legend

- Fringe Open Space
- Other Open Space
- Parking Lot Landscaping (Excluding underpass areas)
- R.O.W. Landscaping

Open Space Calculations

141,312 s.f. Net Lot Area

Required Open Space 24% x Net Lot Area = 33,915 s.f.
36,758 s.f. provided

Required Fringe Open Space 50% x Total Open Space = 16,958 s.f.
19,773 s.f. provided

SPECTRUM
CAMELBACK ROAD
8109 E Camelback Road
Scottsdale, Arizona 85251

OPEN SPACE PLAN

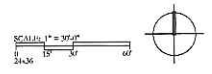

DR25

PRELIMINARY LANDSCAPE PLANS FOR SPECTRUM CAMELBACK ROAD SCOTTSDALE, ARIZONA

GENERAL NOTES:

1. ALL WORK SHALL BE LAID OUT BY LANDSCAPE CONTRACTOR FOR THE OWNER'S APPROVAL PRIOR TO INSTALLATION. ALL PLANT MATERIAL SHALL BE SUBJECT TO OWNER APPROVAL.
2. THIS DRAWING IS PART OF A COMPLETE SET OF BID DOCUMENTS, SPECIFICATIONS, ADDITIONAL DRAWINGS, AND EXHIBITS. UNDER NO CIRCUMSTANCES SHOULD THESE PLANS BE USED FOR CONSTRUCTION PURPOSES WITHOUT EXAMINING ACTUAL LOCATIONS OF UTILITIES ON SITE, AND REVIEWING ALL RELATED DOCUMENTS MENTIONED HEREIN, INCLUDING ANY RELATED DOCUMENTS PREPARED BY THE PROJECT ENGINEERS.
3. THE LANDSCAPE ARCHITECT AND CONSULTANTS DO NOT WARRANT OR GUARANTEE THE ACCURACY AND COMPLETENESS OF THE WORK PRODUCT THEREIN BEYOND A REASONABLE STANDARD OF PROFESSIONAL CARE.
4. IF ANY MISTAKES, OMISSIONS, OR DISCREPANCIES ARE FOUND TO EXIST WITH THE WORK PRODUCT, THE LANDSCAPE ARCHITECT SHALL BE PROMPTLY NOTIFIED SO THAT THEY MAY HAVE THE OPPORTUNITY TO TAKE ANY STEPS NECESSARY TO RESOLVE THE ISSUE. FAILURE TO PROMPTLY NOTIFY THE OWNER AND THE LANDSCAPE ARCHITECT OF SUCH CONDITIONS SHALL ABSOLVE THEM FROM ANY RESPONSIBILITY FOR THE CONSEQUENCES OF SUCH FAILURE.
5. ACTIONS TAKEN WITHOUT THE KNOWLEDGE AND CONSENT OF THE OWNER AND THE LANDSCAPE ARCHITECT OR IN CONTRADICTION TO THE OWNER AND THE LANDSCAPE ARCHITECT'S WORK PRODUCT OR RECOMMENDATIONS, SHALL BECOME THE RESPONSIBILITY NOT OF THE OWNER AND THE LANDSCAPE ARCHITECT BUT FOR THE PARTIES RESPONSIBLE FOR THE TAKING OF SUCH ACTION.
6. THE LOCATION OF THE UNDERGROUND UTILITIES AND/OR DRIVEWAYS ARE LOCATED ON ENGINEERING DRAWINGS PREPARED BY THE PROJECT ENGINEER, THE MOST CURRENT REVISIONS ARE MADE PART OF THE FINAL LANDSCAPE PLANS. PRELIMINARY LANDSCAPE PLANS DO NOT INCLUDE CIVIL ENGINEERING INFORMATION.
7. UNDERGROUND UTILITIES EXIST THROUGHOUT THIS SITE AND MUST BE LOCATED PRIOR TO CONSTRUCTION.
8. WHERE UNDERGROUND UTILITIES EXIST, FIELD ADJUSTMENT MUST BE APPROVED BY A REPRESENTATIVE OF THE OWNER PRIOR TO INSTALLATION.
9. NEITHER THE OWNER NOR THE LANDSCAPE ARCHITECT ASSUMES RESPONSIBILITY WHATSOEVER, IN RESPECT TO THE CONTRACTOR'S ACCURACY IN LOCATING THE INDICATED PLANT MATERIAL.
10. UNDER NO CIRCUMSTANCES SHOULD THESE PLANS BE USED WITHOUT REFERENCING THE ABOVE MENTIONED DOCUMENTS.
11. BASE INFORMATION HAS BEEN PROVIDED BY VESSEL ARCHITECTS. FOR UTILITY LOCATIONS PLEASE REFER TO CIVIL PLANS. THE LOCATIONS OF VARIOUS UTILITIES ON THIS SET OF DRAWINGS IS ONLY ILLUSTRATIVE AND SHOULD NOT BE RELIED UPON FOR CONSTRUCTION PURPOSES.
12. REFER TO CIVIL ENGINEERING DOCUMENTS FOR DETAILED INFORMATION REGARDING SIZE, LOCATION, DEPTH AND TYPE OF UTILITIES.
13. LANDSCAPE PLANS CONTAINED HEREIN ILLUSTRATE APPROXIMATE LOCATIONS OF ALL UTILITIES AS PROVIDED BY THE PROJECT ENGINEER IT IS THE RESPONSIBILITY OF THE CONTRACTOR TO FIELD VERIFY THEIR ACCURACY.
14. LOCATIONS OF ALL PLANT MATERIAL ILLUSTRATED ON THE LANDSCAPE PLANS ARE APPROXIMATE. FINAL LOCATIONS SHALL BE DETERMINED IN THE FIELD.
15. LANDSCAPE CONTRACTOR SHALL REFER TO THE PROVIDED WRITTEN SPECIFICATIONS WHEN LOCATING AND PLANTING SPECIFIED PLANT MATERIAL.
16. CONTRACTOR TO ENSURE SOO OR GRAVEL MULCH IS PLACED BELOW SIDEWALK AND PATIO ELEVATIONS TO ALLOW FOR PROPER DRAINAGE.
17. THE LANDSCAPE CONTRACTOR SHALL TAKE ALL NECESSARY PRECAUTIONS TO PROTECT ANY EXISTING BUILDINGS OR STRUCTURES ON THE SITE AND SHALL BE HELD RESPONSIBLE FOR ANY DAMAGE CAUSED BY HIS WORK.
18. IT SHALL BE THE RESPONSIBILITY OF THE LANDSCAPE CONTRACTOR TO PREVENT PLANTS FROM FALLING OR BEING BLOWN OVER AND TO STRAIGHTEN OR REPLANT ALL PLANTS WHICH ARE DAMAGED DUE TO LACK OF CULPING OR STAKING. PLANTS BLOWN OVER BY WIND SHALL NOT CAUSE ADDITIONAL EXPENSE TO THE OWNER BUT SHALL BE THE FINANCIAL RESPONSIBILITY OF THE LANDSCAPE CONTRACTOR.

PREPARED FOR :
SPECTRUM RETIREMENT COMMUNITIES, LLC
200 SPRUCE STREET, SUITE 200
DENVER, CO 80230

PREPARED BY:
ALLEN L. KRACOWER & ASSOCIATES, INC.
900 North Shore Drive, Suite 205
Lake Bluff, Illinois 60044
(847) 604-9600
and
KLESKI & ASSOCIATES
4340 E. Indian School Rd, Suite 211-229
Phoenix, Arizona 85018
(602)999-7021

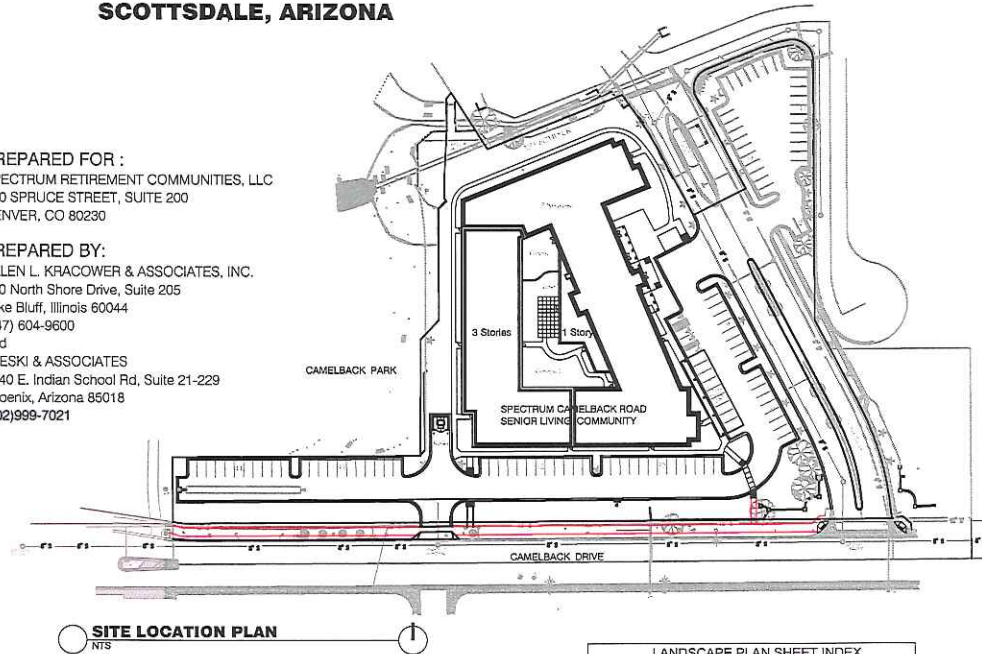

Preliminary Summary Data	
Zoning:	CO, Commercial Office Zoning
Total Site Acreage:	4.2 Acres
Net Site Acreage:	3.2 Acres (Subject Site)
Landscape Area:	58,531 Sq. Ft.
Camelback Road ROW:	10,149 Sq. Ft. (Incl. new 8' walk)
Proposed Trees:	64 Trees
Parking lot landscape:	2,415 Sq. Ft.

LANDSCAPE PLAN SHEET INDEX	
SHEET #	
C/R	DRAWING INDEX REQUIREMENTS & GENERAL NOTES
L-1	OVERALL LANDSCAPE PLAN KEY MAP
L-2	LANDSCAPE PLAN - SOUTH EAST
L-3	LANDSCAPE PLAN - SOUTH
L-4	LANDSCAPE PLAN - SOUTH WEST
L-5	LANDSCAPE PLAN - ENTRANCE
L-6	LANDSCAPE PLAN - NORTH BUFFER
L-7	LANDSCAPE PLAN - INTERIOR COURTYARDS & PLANT LIST

REVISIONS	
DATE	DESCRIPTION

**PRELIMINARY LANDSCAPE PLANS
AUGUST 7, 2019**



DRAWING INDEX & GENERAL NOTES

SPECTRUM CAMELBACK ROAD
8102 E. Camelback Road
Scottsdale, Arizona

DATE	DESCRIPTION
08-1-19	DRB Re-Submittal
08-13-19	DRB Re-Submittal
08-21-19	DRB Re-Submittal

CVR

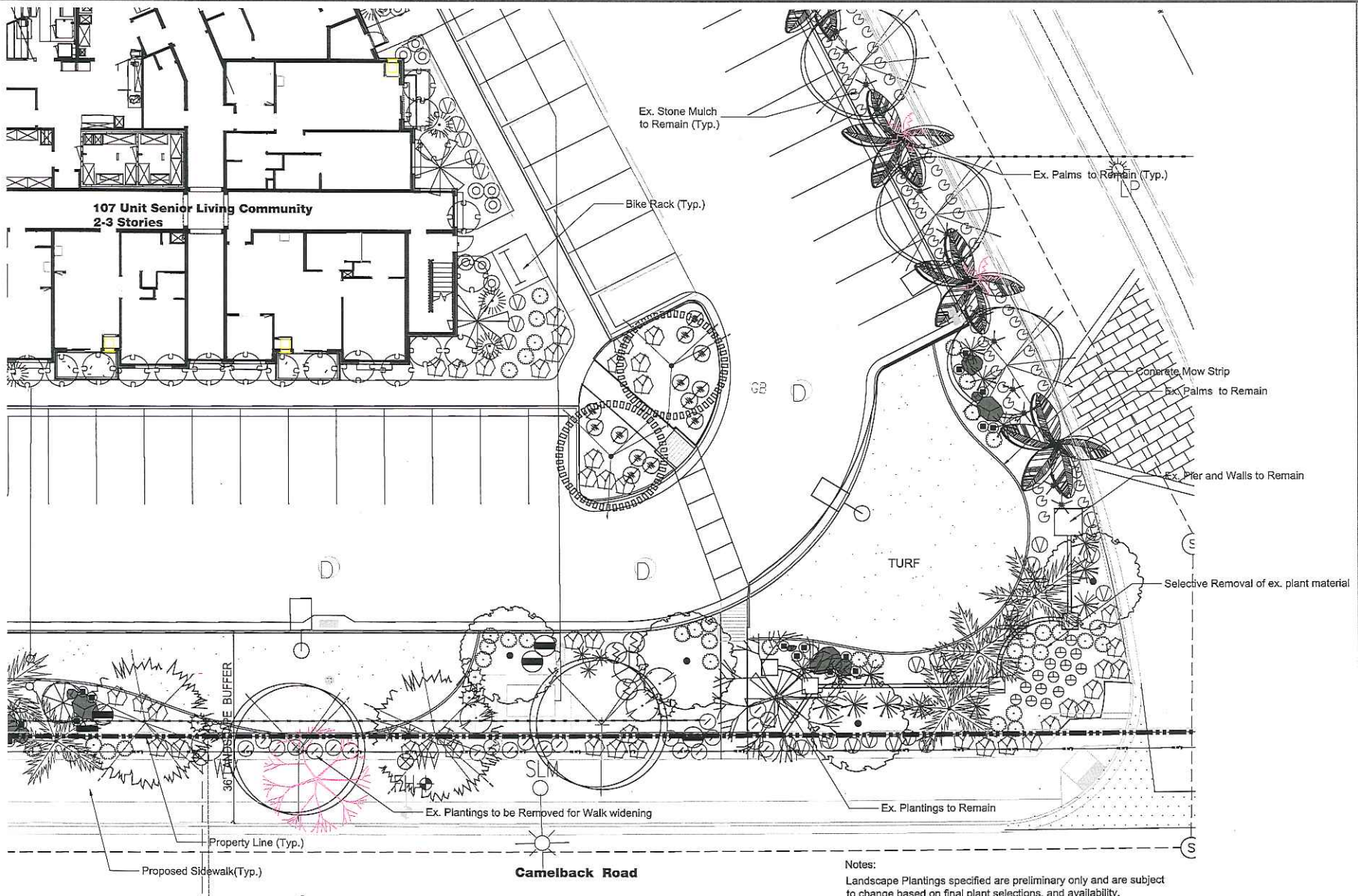

1 PRELIMINARY LANDSCAPE PLAN
SCALE: 1/8"=1'-0"

Notes:
Landscape Plantings specified are preliminary only and are subject to change based on final plant selections, and availability.
All landscaping will be supported by an automatic irrigation system and will be designed constructed and maintained to promote water conservation and prevent water overflow into the street, sidewalk or parking lots.

Kleski & Associates
Landscape Architects
4815 East Camelback Road, Suite 112, Scottsdale, AZ 85251
Phone: 480.343.7279



PROJECT: PRELIMINARY LANDSCAPE PLAN-SOUTHEAST

SPECTRUM CAMELBACK ROAD

8102 E. Camelback Road
Scottsdale, Arizona

DATE:	DATE:
1/20/2019	1/20/2019
2/28/2019	2/28/2019
3/14/2019	3/14/2019
4/11/2019	4/11/2019
5/15/2019	5/15/2019

PROJECT NUMBER:	CLIENT:
21501.1	KAR
DATE:	DESIGNER:
AS NOTED	LD
DATE:	PROJECT NUMBER:
1-8-2019	KAR

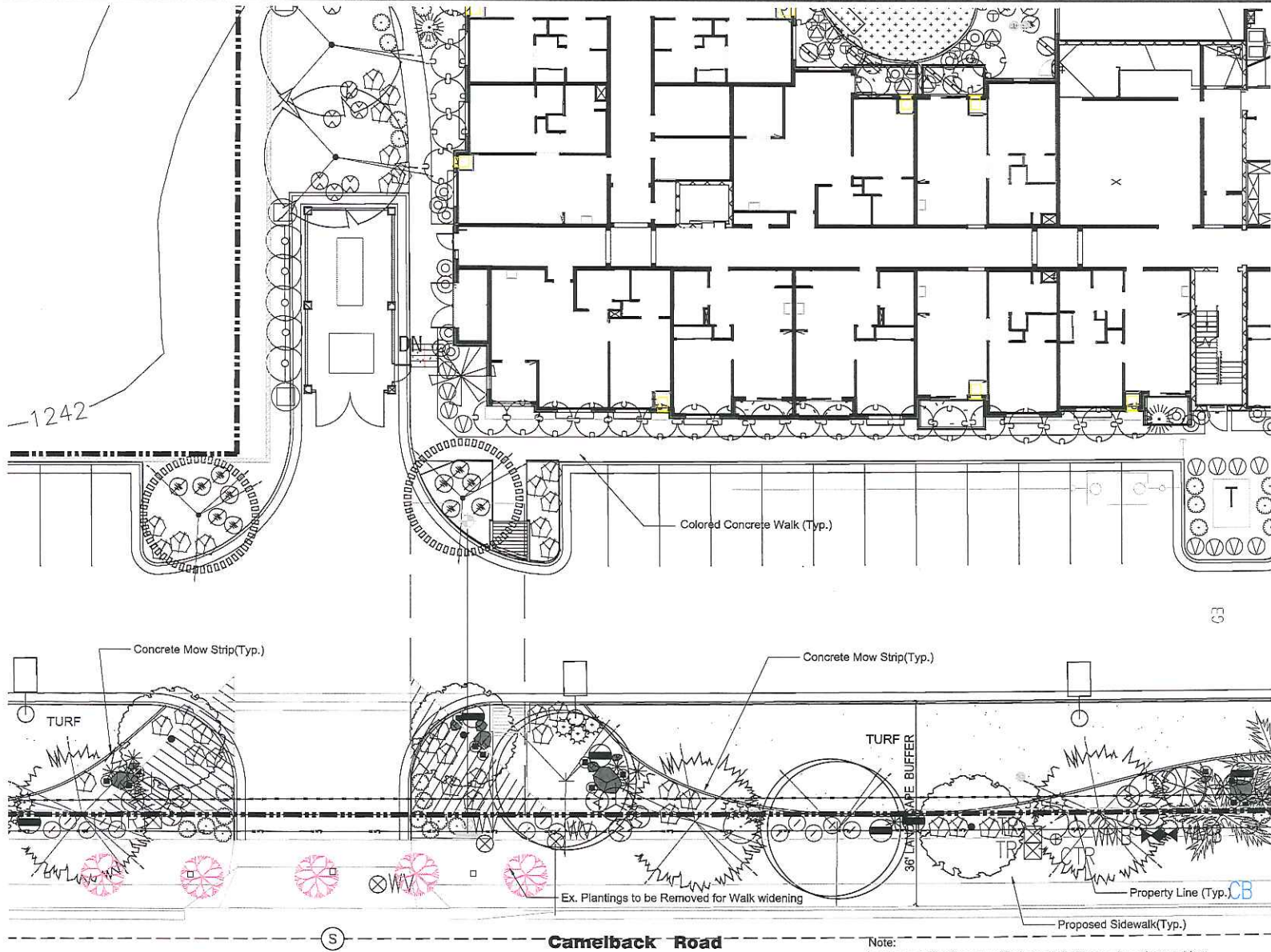

1 PRELIMINARY LANDSCAPE PLAN
SCALE: 1/8"=1'-0"

Note:
Landscape Plantings specified are preliminary only and are subject to change based on final plant selections, and availability.
All landscaping will be supported by an automatic irrigation system and will be designed constructed and maintained to promote water conservation and prevent water overflow into the street, sidewalk or parking lots.

Kleski & Associates
Landscape Architects
4811 East Camelback Road, Suite 100
Phoenix, AZ 85018
Phone: 602.953.3111



ALISHA SPACOMER
Landscape Architect
AIA No. 100000000



PRELIMINARY LANDSCAPE PLAN-SOUTH

SPECTRUM CAMELBACK ROAD

8102 E. Camelback Road
Scottsdale, Arizona

DATE	NO.

PROJECT NO.	21951.1	DATE	1-8-2018
DESIGNER	AS NOTED	DATE	1-8-2018
SCALE	AS NOTED	DATE	1-8-2018

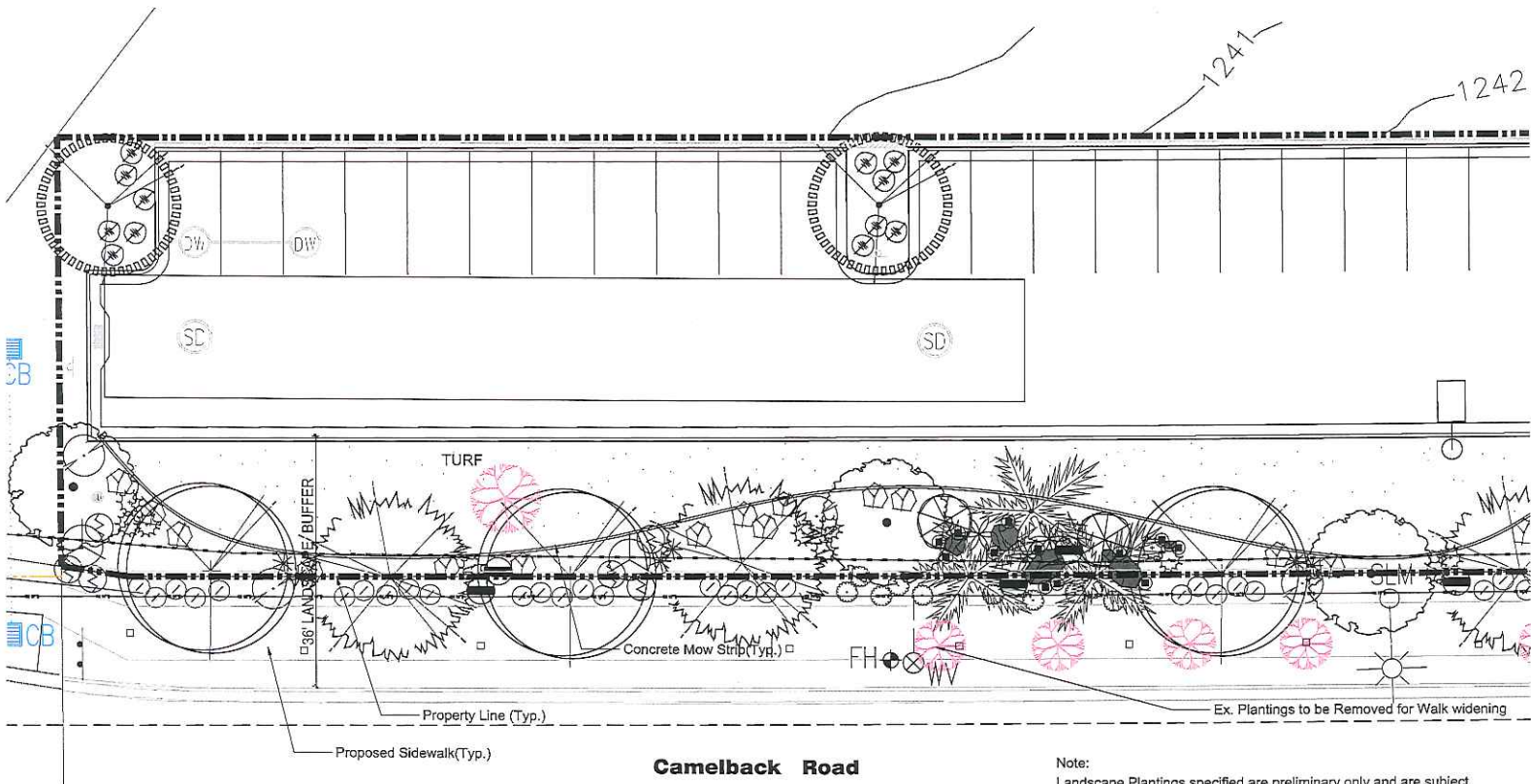

1 PRELIMINARY LANDSCAPE PLAN
SCALE: 1/8"=1'-0"



Note:
Landscape Plantings specified are preliminary only and are subject to change based on final plant selections, and availability.
All landscaping will be supported by an automatic irrigation system and will be designed constructed and maintained to promote water conservation and prevent water overflow into the street, sidewalk or parking lots.

Klaski & Associates
Landscape Architects
4815 E. Camelback Road, Suite 200
Phoenix, AZ 85018
Phone: 602.997.9991



ALLEN L. BRACOMER
Landscape Architect
11111 N. 28th Ave., Suite 100
Scottsdale, AZ 85258
Phone: 480.443.4444



PRELIMINARY LANDSCAPE PLAN-WEST
SPECTRUM CAMELBACK ROAD
8102 E. Camelback Road
Scottsdale, Arizona

DATE	DESCRIPTION

PROJECT NUMBER	31501.1	DATE	1/5/19
DESIGNER	AS NOTED	DATE	1/5/19
DATE	1-5-2019	DATE	1/5/19
DATE		DATE	

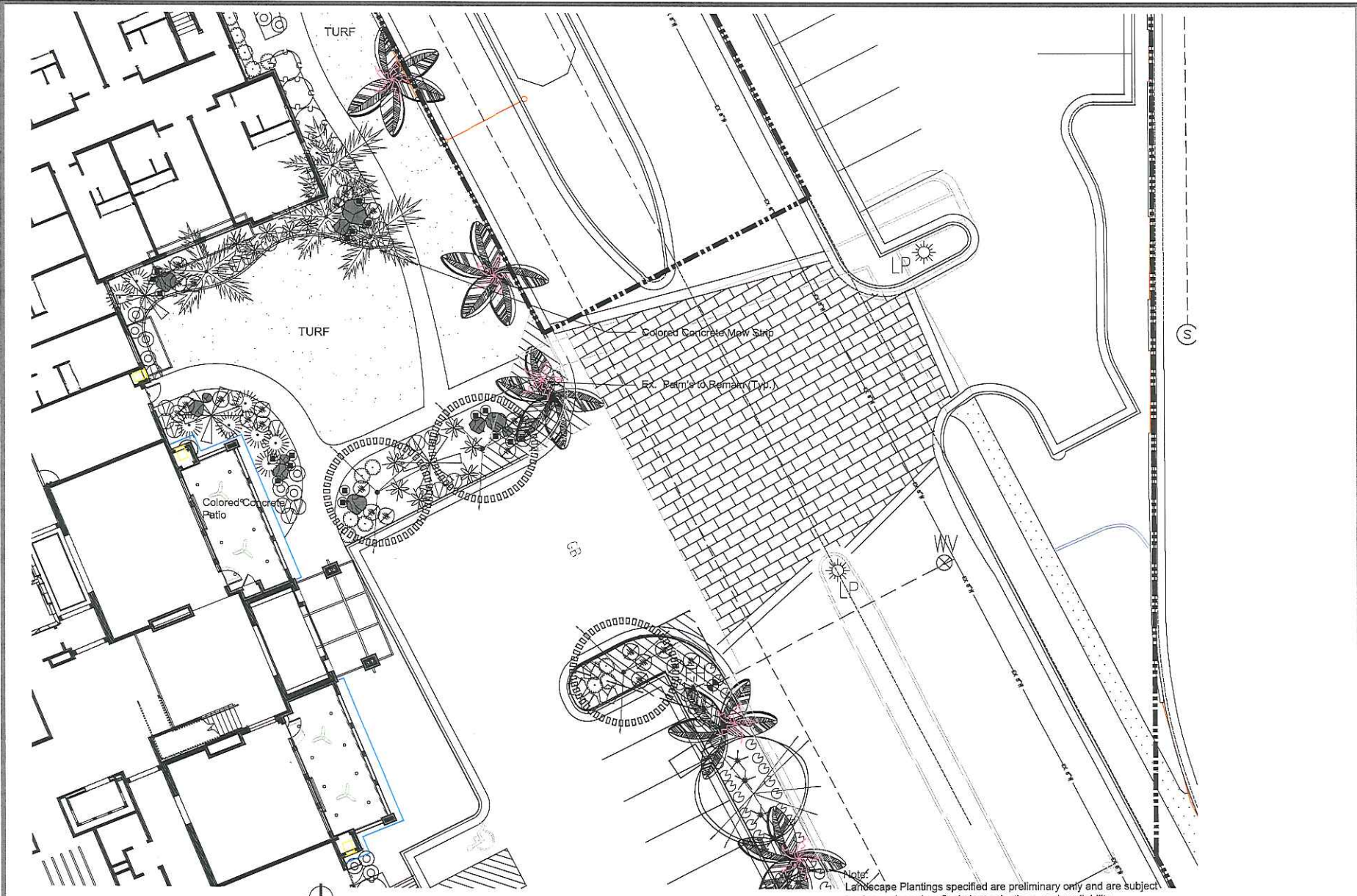

1 PRELIMINARY LANDSCAPE PLAN
SCALE: 1/8"=1'-0"

Note:
Landscape Plantings specified are preliminary only and are subject to change based on final plant selections, and availability.
All landscaping will be supported by an automatic irrigation system and will be designed constructed and maintained to promote water conservation and prevent water overflow into the street, sidewalk or parking lots.

Kleski & Associates
Landscape Architects
10000 N. 19th Street, Suite 100
Phoenix, AZ 85024
Phone: 602.955.8888



ALBERT L. BRACCOMER
Landscape Architect
10000 N. 19th Street, Suite 100
Phoenix, AZ 85024
Phone: 602.955.8888



SPECTRUM
RETAILMENT CONSULTING, LLC

PRELIMINARY ENTRY LANDSCAPE PLAN

SPECTRUM CAMELBACK ROAD

8102 E. Camelback Road
Scottsdale, Arizona

NO.	DATE	DESCRIPTION	BY

PROJECT NO.	DATE	DESIGNER
219011		KAK
		LD



1 PRELIMINARY LANDSCAPE PLAN
SCALE: 1/8"=1'-0"

Note:
Landscape Plantings specified are preliminary only and are subject to change based on final plant selections, and availability.

All landscaping will be supported by an automatic irrigation system and will be designed constructed and maintained to promote water conservation and prevent water overflow into the street, sidewalk or parking lots.

Kleski & Associates
Landscape Architects
4912 East Green Valley Road • Suite 127
Phoenix, AZ 85032
www.kleski.com

ALBERT KRACOWER
Landscape Architect
www.albertkracower.com

SPECTRUM
MEMBERSHIP DEVELOPMENT, LLC

PRELIMINARY LANDSCAPE PLAN-NORTH BUFFER
SPECTRUM CAMELBACK ROAD
8102 E. Camelback Road
Scottsdale, Arizona

NO.	DESCRIPTION	DATE

DATE PREPARED	DATE PLOTTED
2/15/2018	NAK
DATE AS NOTED	DATE PLOTTED
1-8-2018	LD
DATE CHECKED	DATE PLOTTED
1-8-2018	RAK

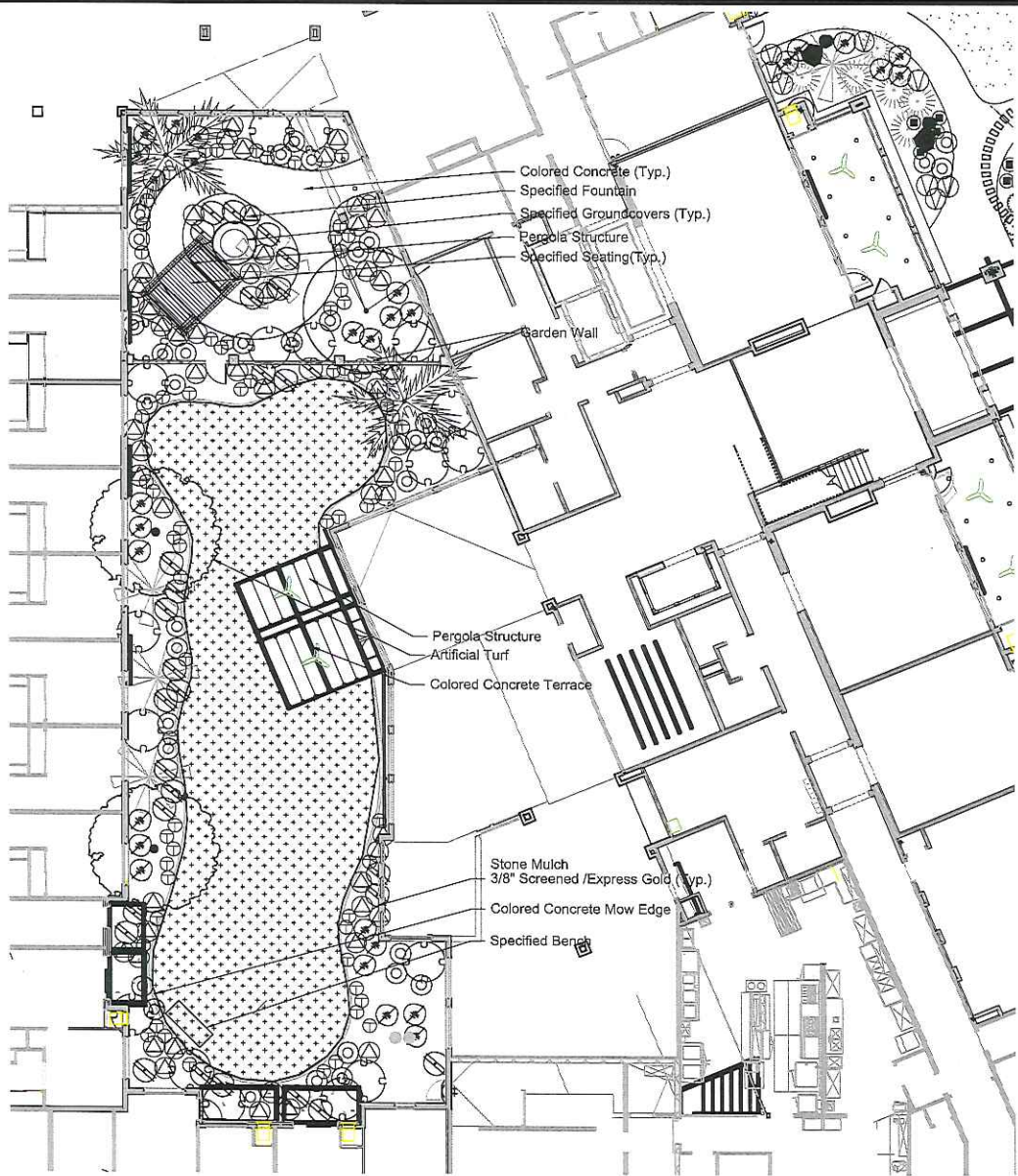

1 PRELIMINARY LANDSCAPE PLAN-INTERIOR COURTYARDS
SCALE: 1/8" = 1'-0"

PLANT SCHEDULE

SYMBOL	BOTANICAL NAME	COMMON NAME	SIZE	QTY	COMMENTS
TREES					
	<i>Acacia aneura</i>	Mulga	36" Box	1	Single-Trunk, Dense Canopy
	<i>Brahea ornata</i>	Mexican Blue Palm	10" CTH	24	Single-Trunk, Dense Canopy
	<i>Casalpinia mexicana</i>	Mexican Bird of Paradise	24" Box	12	Multi-Trunk, Dense Canopy
	<i>Chilopsis linearis</i>	AZT Desert Amethyst	36" Box	6	Multi-Trunk, Dense Canopy
	<i>Olea europaea 'Sour Hill'</i>	Fruitless Olive	36" Box	9	Multi-Trunk, Dense Canopy
	<i>Parkinsonia 'Desert Museum'</i>	Desert Museum	36" Box	7	Multi-Trunk, Dense Canopy
	<i>Platanus 'Red Push'</i>	Red Push Platanus	2" Caliper	12	Single-Trunk, Dense Canopy
	<i>Prosopis chilensis</i>	Thornless Mesquite	24" Box	7	Multi-Trunk, Dense Canopy
	<i>Quercus virginiana 'Heritage'</i>	Live Oak	2" Caliper	6	Single-Trunk, Dense Canopy
ACCENTS					
	<i>Agave desertiana</i>	Smooth Agave	5-Gal	25	As Per Plan
	<i>Agave parvifl.</i>	Pony's Agave	5-Gal	18	As Per Plan
	<i>Chamaeceras humilis</i>	Mediterranean Fan Palm	24" Box	17	3 trunk min.
	<i>Dasylirion longesim.</i>	Toothless Spoon	5-Gal	14	As Per Plan
	<i>Echinocactus grusonii</i>	Golden Barrel Cactus	5-Gal	15	As Per Plan
	<i>Fouquieria splendens</i>	Cholla	Boreroot	8	10 Cane Minimum
	<i>Hesperaloe parviflora</i>	Red & Yellow Yucca	5-Gal	18	As Per Plan
	<i>Nolina microcarpa</i>	Spear Grass	5-Gal	27	As Per Plan
	<i>Opuntia santa rita</i>	Purple Prickly Pear	5-Gal	23	As Per Plan
	<i>Yucca baccata</i>	Banana Yucca	5-Gal	15	As Per Plan
SHRUBS					
	<i>Atriplex subulata</i>	Desert Milkweed	5-Gal	15	As Per Plan
	<i>Bougainvillea</i>	Barbara Karst	5-Gal	10	As Per Plan
	<i>Casalpinia pulcherrima</i>	Red Bird of Paradise	5-Gal	6	As Per Plan
	<i>Callistemon citrinus</i>	Little John	5-Gal	27	As Per Plan
	<i>Cordia parvifolia</i>	Little Leaf Cordia	5-Gal	11	As Per Plan
	<i>Dielsia sp.</i>	Iris	5-Gal	51	As Per Plan
	<i>Dodonea viscosa 'Purpurea'</i>	Purple Hop Bush	5-Gal	15	As Per Plan
	<i>Encelia torinosa</i>	Brittle Bush	5-Gal	15	As Per Plan
	<i>Eremophila maculata</i>	Valentine Bush	5-Gal	18	As Per Plan
	<i>Jussiaea spiraeifera</i>	Mexican Honeycucule	5-Gal	90	As Per Plan
	<i>Leucophyllum laevigatum</i>	Chihuahuan Sage	5-Gal	18	As Per Plan
	<i>Leucophyllum zygomphylum</i>	Blue Ranger	5-Gal	22	As Per Plan
	<i>Simmondsia chinensis</i>	Jojoba	5-Gal	10	As Per Plan
	<i>Tecoma sp.</i>	Sparidette	5-Gal	111	As Per Plan
	<i>Tecoma etena</i>	Yellow Bells	5-Gal	95	As Per Plan
GROUND COVERS					
	<i>Coriaria</i>	Boxwood Beauty	1-Gal	108	As Per Plan
	<i>Convolvulus aneorum</i>	Bush Morning Glory	1-Gal	110	As Per Plan
	<i>Dalea greggii</i>	Trailing Dalea	1-Gal	66	As Per Plan
	<i>Lantana 'New Gold'</i>	New Gold Lantana	1-Gal	142	As Per Plan
	<i>Lantana montevidensis</i>	Trailing Lantana	1-Gal	116	As Per Plan
	<i>Penstemon sp.</i>	Penstemon	1-Gal	56	As Per Plan
	<i>Ruellia brittaniana 'Katie'</i>	Katie Ruellia	1-Gal	67	As Per Plan
MISCELLANEOUS					
Decomposed Granite - (Size: 1/2" Screened, Color: Express Gold) 2" depth in all planting areas (typ) -					
Landscape Boulders: 20% 4' dia., 40% 3' dia., 40% 2' dia., Color: Surface Select Boulders. - Submit photos to Landscape Architect for approval prior to purchase and installation.					
	Turf Sod: Midlawn Bermuda hybrid				

Note:
Landscape Plantings specified are preliminary only and are subject to change based on final plant selections, and availability.
All landscaping will be supported by an automatic irrigation system and will be designed constructed and maintained to promote water conservation and prevent water overflow into the street, sidewalk or parking lots.

Kleski & Associates
Landscape Architects
4801 East Camelback Road, Suite 212-202
Phoenix, AZ 85018
www.kleski.com

ALLEN L. KRACOWER
Landscape Architect
1000 North Central Expressway, Suite 100
Scottsdale, AZ 85262
www.allenkracower.com

SPECTRUM
Landscape Architecture, LLC

PRELIMINARY LANDSCAPE PLAN-COURTYARDS & PLANT LIST

SPECTRUM CAMELBACK ROAD
8102 E. Camelback Road
Scottsdale, Arizona

PROJECT NUMBER	21901.1
DATE	AS NOTED
SCALE	1-5-2019
PROJECT MANAGER	KAK
DESIGNER	LD

DATE	6-7-19
DATE	6-4-19
DATE	5-1-19

L-7

9 APR 2019 11:21:19



NORTHEAST ELEVATION



SOUTH ELEVATION



WEST ELEVATION

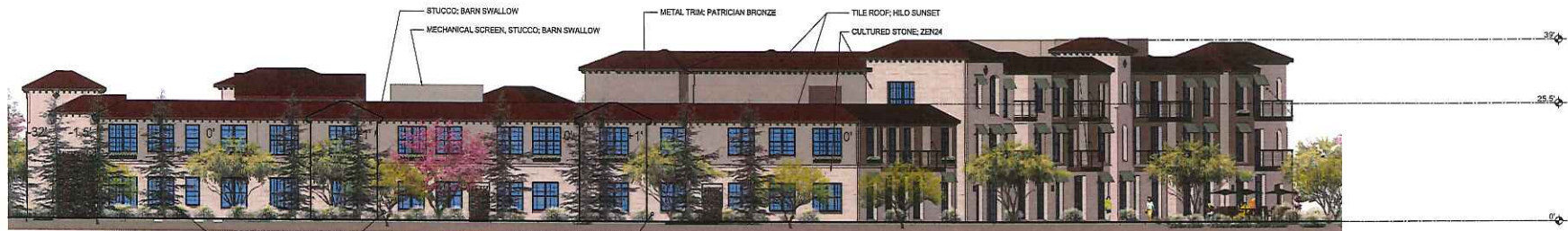

NORTHWEST ELEVATION



ARCHITECTURE & DESIGN



SPECTRUM

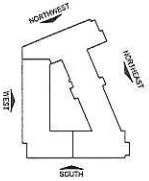

SPECTRUM
CAMELBACK ROAD
8102 E Camelback Road
Scottsdale, Arizona 85251

BUILDING ELEVATIONS

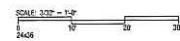

DR37a

ATTACHMENT 7



ARCHITECTURE & DESIGN



SPECTRUM

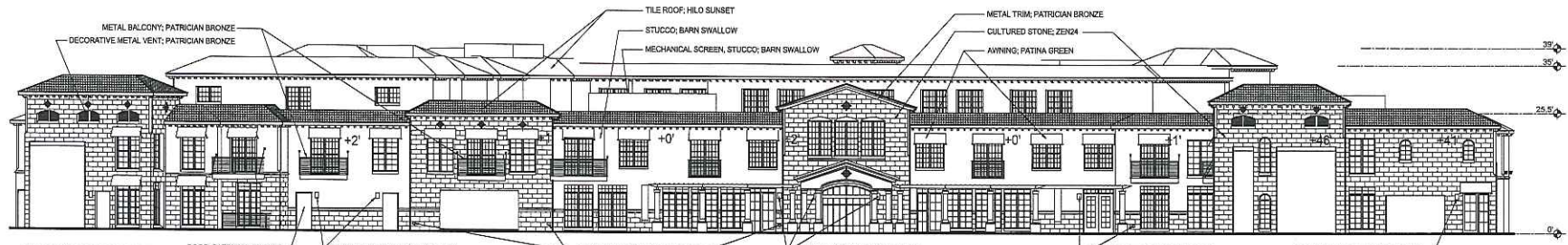
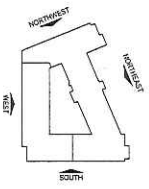

NORTHEAST ELEVATION

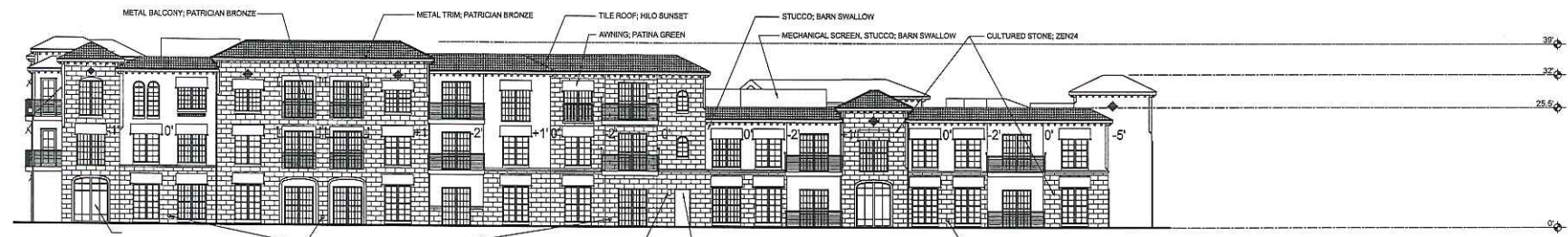

SOUTH ELEVATION

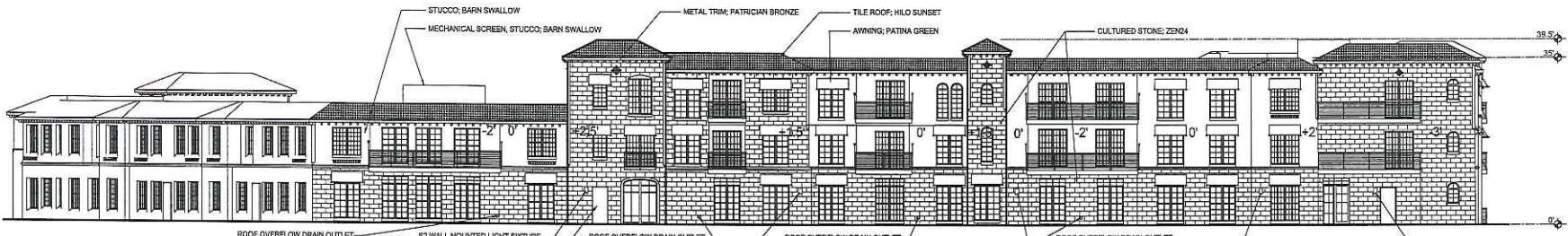

WEST ELEVATION

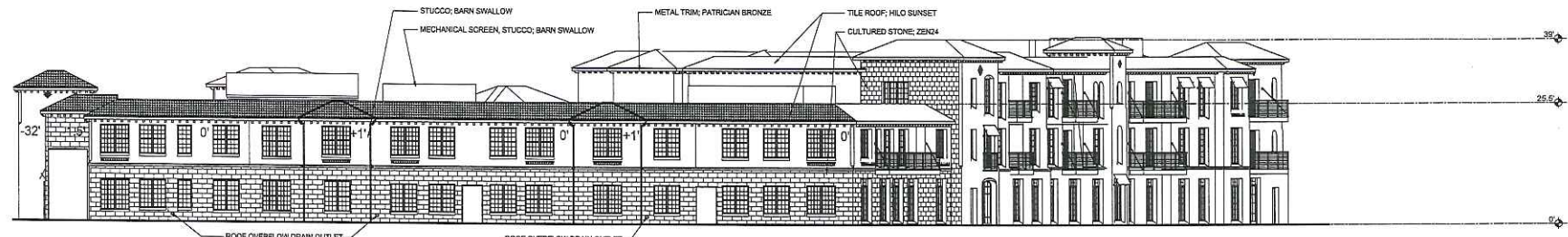

NORTHWEST ELEVATION

SPECTRUM
CAMELBACK ROAD
8102 E Camelback Road
Scottsdale, Arizona 85251

BUILDING ELEVATIONS



DR37b

ATTACHMENT 8



TILE ROOFING
EAGLE ROOFING, CAPISTRANO
COLOR: 3124 HILO SUNSET



SPECTRUM CAMELBACK
1.14.2019



METAL TRIM
KYNAR 500
COLOR: PATRICIAN BRONZE



SPECTRUM CAMELBACK
1.2019



METAL AWNING
KYNAR 500
COLOR: PATINA GREEN

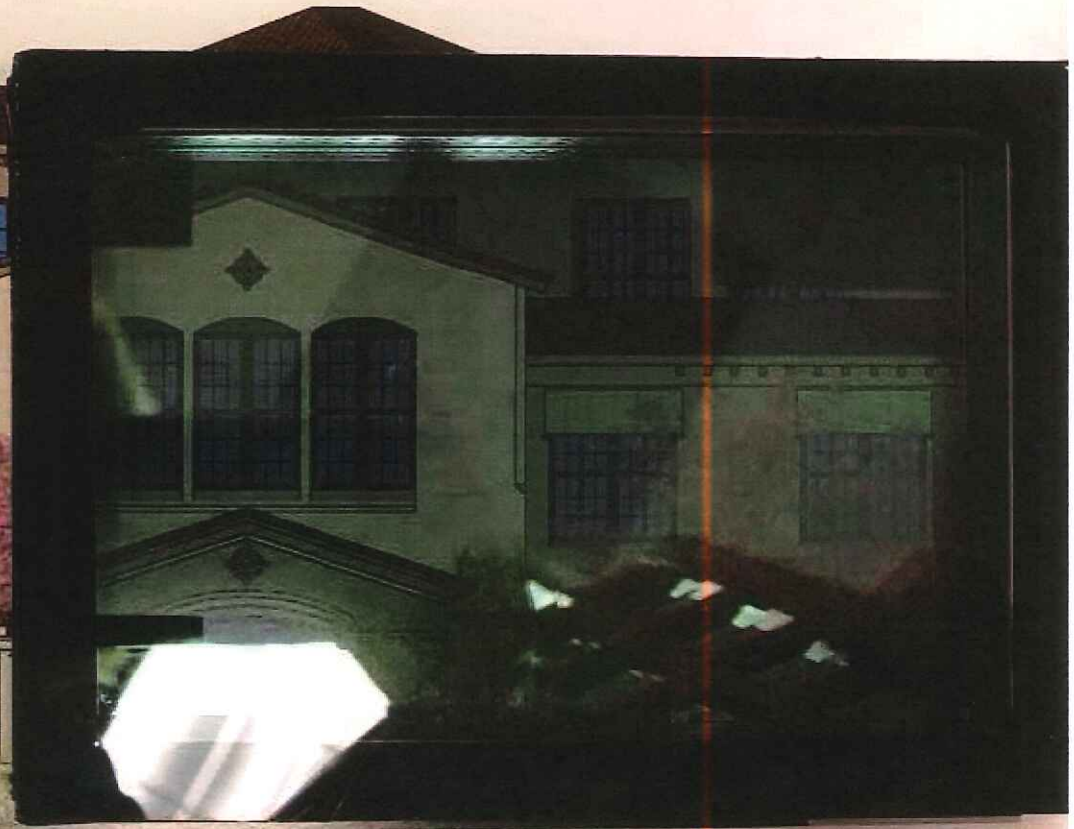

GLASS
VIRAGON, VRE1-43

SPECTRUM CAMELBACK
1.2019





MANUFACTURED STONE
ELDORADO STONE, ZEN24
COLOR: SOFT LIGHT



SPECTRUM CAMELBACK
1.2019



STUCCO
OMEGA COLORTEK
COLOR: #404 BARN SWALLOW



ARCHITECTURE & DESIGN

SPECTRUM CAMELBACK
1.2019

Calculation Summary (Vertical-L1-F1.0)					
At 6' AFD @ Property Line	CalcType	Output	Avg	Min	Max
CalcFts	Illuminance	Fc	0.6	0.7	0.6

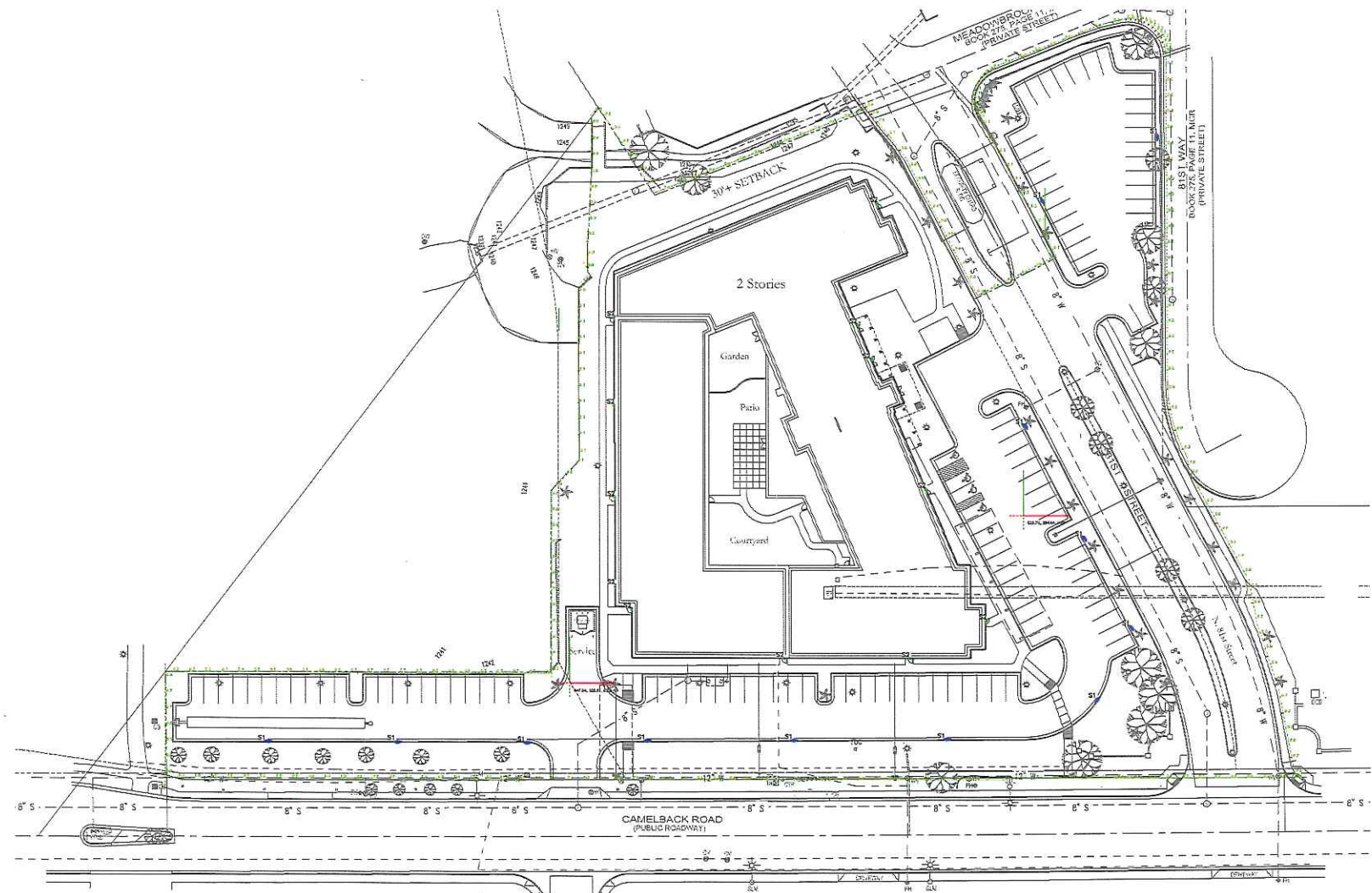

ELECTRICAL SITE LIGHTING PHOTOMETRIC PLAN
SCALE: 1" = 30' - 0"



SEAL

#	DATE	SUBMISSION

SPECTRUM
CAMELBACK ROAD
Scottsdale, Arizona

ELECTRICAL
SITE LIGHTING
PHOTOMETRIC PLAN

DR46-2

2019191

8-DR-2019
9/7/2019

Calculation Summary (Horizontal - LF=0.71)

Label	CalcType	Unit	AVG	MAX	MIN	Avg/Min	Max/Min
CalcPts	Illuminance	Fc	2.7	5.5	0.5	N.A.	N.A.

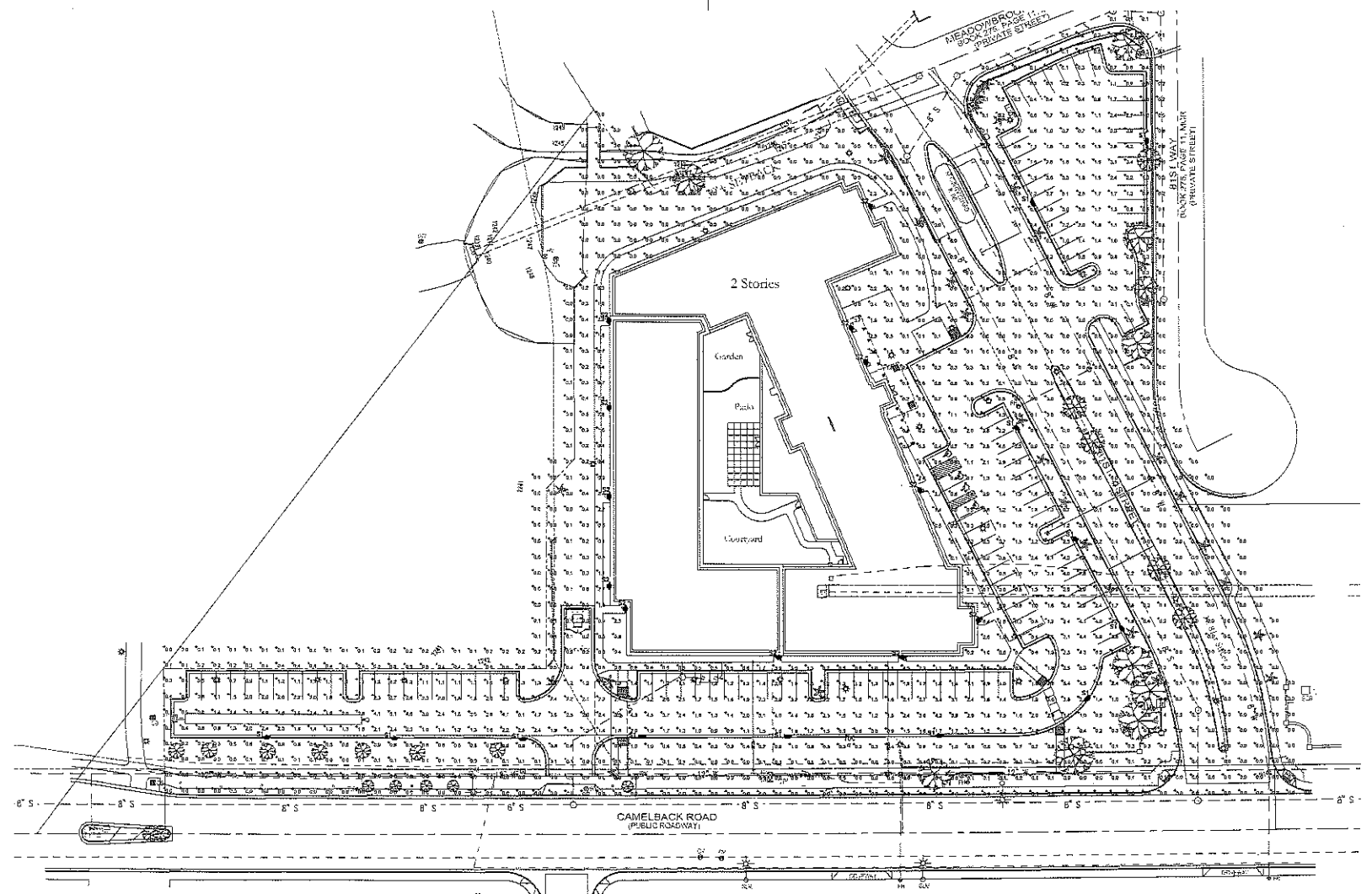

ELECTRICAL SITE LIGHTING PHOTOMETRIC PLAN
 SCALE: 1" = 30' - 0"



ARCHITECTURE & DESIGN
 850 Emerald Rd. Ste 100, St. Louis, Missouri 63141
 p 314 251 0122 / f 314 251 0122 / www.spectrarch.com



SPECTRUM

STRUCTURAL & MEP ENGINEERS
 SSG Engineering, Inc.
 www.ssgengineering.com

SEAL

#	DATE	SUBMISSION

SPECTRUM
 CAMELBACK ROAD

Scottsdale, Arizona

ELECTRICAL
 SITE LIGHTING
 PHOTOMETRIC PLAN

DR46-1

2019/02

8-CR-2019
 6/22/19

PHILIPS



Site & Area

PureForm

21" housing



Project: _____
 Location: _____
 Cat.No: _____
 Type: _____
 Qty: _____
 Notes: _____

Philips Gardco PureForm luminaires combine LED performance excellence and advanced LED thermal management technology with a distinct purity of style to provide outdoor area lighting that is both energy efficient and aesthetically pleasing. PureForm is defined by its high performance, sleek low profile design and rugged construction.

Ordering guide

example: P21-APD-A1-1-5M-130LA-NW-120-NP-PCB

Prefix	Controls	Arm	Mounting	Optical System ⁸	Wattage	Color Temp	Voltage	Finish	Options
P21									
P21- PureForm 21" fixture	— Standard luminaire DIM 0-10V Dimming APD ¹ Automatic Profile Dimming APD-MRO ² APD with Motion Response Override pole mounted sensor APD-MRI ³ APD with Motion Response Override luminaire mounted sensor MRI ³ Motion Response at 50% low, luminaire mount sensor MR50 ² Motion Response at 50% low, pole mounted sensor Wireless Controls (Remote wireless controller available. See p.2 for details) LLC2 ^{4,5} #2 lens for 8' mounting heights LLC3 ^{4,5} #3 lens for 9-20' mounting heights LLC4 ^{4,5} #4 lens for 21-40' mounting heights	A1 ⁵ Standard 9" Arm A2 ⁵ Short 5" Arm A3 ⁶ Decorative Arm MA Mast Arm Fitter (requires 2 1/2" O.D. Mast Arm)	1 Standard 2 2@180 2@90 2@90 3 3@90 3@120 3@120 4 4@90 W Wall Mount WS ⁷ Wall mount including surface conduit rear entry permitted	Standard Optic Position 2 Type 2 3 Type 3 4 Type 4 5M Type 5 Medium 5W Type 5 Wide BLC Backlight Ctrl 2BL Type 2 with backlight (less shield) LCL ⁹ LEED Corner Cutoff Optics LCR ⁹ LEED Corner Cutoff Optics Optics Rotated Left (90°) ¹⁰ 2-90 Type 2 3-90 Type 3 4-90 Type 4 BLC-90 Backlight Ctrl 2BL-90 Type 2 with backlight (less shield) Optic Rotated Right (270°) ¹⁰ 2-270 Type 2 3-270 Type 3 4-270 Type 4 BLC-270 Backlight Ctrl 2BL-270 Type 2 with backlight (less shield)	350mA 55LA 70LA 90LA 530mA 80LA 105LA 130LA 640mA 165LA ¹¹ 700mA 110LA 140LA 180LA 800mA 200LA ¹¹	CW Cool White 5,700K 70LA 70CRI (nominal) NW Neutral White 4,000K 70CRI (nominal) WW Warm White 3,000K 80CRI (nominal) HVU 347-480V 50hz/60hz	120 120V 208 208V 240 240V 277 277V 347 347V 480 480V UNV 120-277V 50hz/60hz 480V 347-480V 50hz/60hz	BRP Bronze Paint BLP Black Paint WP White Paint NP Natural Paint OC Optional Color Specify optional color or RAL (ex: OC-LGP or OC-RAL7024) SC Special color Specify, must supply color chip. Requires factory quote.	TL Tool-Less entry and driver removal hardware TB Terminal Block F ¹² Fusing LF In-Line/In-Pole Fusing PC ^{4,5,13} Receptacle with Photocell (Includes PCR5) PCB ^{4,5,13} Photocell Button PCR5 ^{4,5,14,15} Photocell Receptacle only with 2 dimming connections PCR7 ^{4,5,15,16} Photocell Receptacle only with 2 dimming and 2 auxiliary connections EHHS External Houseside Shield PTF2 Pole Top Fitter for 2 3/8"-3" Tenon PTF3 Pole Top Fitter for 3"-3 1/2" Tenon PTF4 Pole Top Fitter for 3 1/2"-4" Tenon SPA1-2 Square Pole Adapter for use with A1 or A2 Arms SPA3 ⁶ Square Pole Adapter for use with A3 Arms DL ¹⁷ Diffusing Lens CLR ¹⁷ Clear Glass Lens POLY ¹⁷ Polycarbonate Lens (1 year warranty on lens) BD Bird Deterrent Spike Kit – consist of 25 injection molded plastic bird deterrent spikes (field installed only).

- Available 120-277V only (UNV, 120, 208, 240 & 277).
- Available 120V or 277V only. MR50 and APD-MRO require one motion sensor per pole, ordered separately. See page 2 for Accessories.
- Available 120V or 277V only. Wattages 180LA and 200LA require outboarded sensor enclosure mounted to the arm of the luminaire (A1 arm only).
- Not available with A3 Arm Style.
- LLC2/LLC3/LLC4 wireless controls not configurable with PC/PCB/PCR5/PCR7 Options. See pages 6-7 for more info.
- Arm Styles mount to a round pole with no adapter. If mounting to a square pole, specify Square Pole Adapter option: SPA1-2 for A1/A2 arms, or SPA3 for A3 arms.
- Available with A1 or A2 Arms only. Not available in P21-MR50, or P21-APD-MRO.
- Luminaire door frame and optic assembly provided standard without glass lens. Specify CLR option for clear glass lens.
- Available with 130LA or 200LA only.
- See page 8-9 for information on optical rotation prior to ordering.
- 200LA and 165LA not available in 347V or 480V.
- Available with A1 arm or with MA mounting only. Provide specific input voltage.
- Not configurable with 480V. Voltage must be specified.
- Works with 3-pin or 5-pin NEMA photocell/dimming device.
- If ordered with DIM, APD, MRI, MR50, APD-MRI, APD-MRO, dimming will not be connected to NEMA receptacle.
- Works with 3-pin or 5-pin NEMA photocell/dimming device and auxiliary connections are not connected (for future use only).
- Option reduces performance.

DESCRIPTION

The patented Lumark Crosstour™ LED Wall Pack Series of luminaires provides an architectural style with super bright, energy efficient LEDs. The low-profile, rugged die-cast aluminum construction, universal back box, stainless steel hardware along with a sealed and gasketed optical compartment make the Crosstour impervious to contaminants. The Crosstour wall luminaire is ideal for wall/surface, inverted mount for façade/canopy illumination, post/bollard, site lighting, floodlight and low level pathway illumination including stairs. Typical applications include building entrances, multi-use facilities, apartment buildings, institutions, schools, stairways and loading docks test.

SPECIFICATION FEATURES

Construction

Slim, low-profile LED design with rugged one-piece, die-cast aluminum hinged removable door and back box. Matching housing styles incorporate both a small and medium design. The small housing is available in 12W, 18W and 26W. The medium housing is available in the 38W model. Patented secure lock hinge feature allows for safe and easy tool-less electrical connections with the supplied push-in connectors. Back box includes three half-inch, NPT threaded conduit entry points. The universal back box supports both the small and medium forms and mounts to standard 3-1/2" to 4" round and octagonal, 4" square, single gang and masonry junction boxes. Key hole gasket allows for adaptable to junction box or wall. External fin design extracts heat from the fixture surface. One-piece silicone gasket seals door and back box. Minimum 5" wide pole for site lighting application. Not recommended for car wash applications.

Optical

Silicone sealed optical LED chamber incorporates a custom engineered mirrored anodized reflector providing high-efficiency illumination. Optical assembly includes impact-resistant tempered glass and meets IESNA requirements for full cutoff compliance. Available in seven lumen packages; 5000K, 4000K and 3000K CCT.

Electrical

LED driver is mounted to the die-cast housing for optimal heat sinking. LED thermal management system incorporates both conduction and natural convection to transfer heat rapidly away from the LED source. 12W, 18W, 26W and 38W series operate in -40°C to 40°C [-40°F to 104°F]. High ambient 50°C models available. Crosstour luminaires maintain greater than 89% of initial light output after 72,000 hours of operation. Three half-inch NPT threaded conduit entry points allow for thru-branch wiring. Back box is an authorized

Catalog #		Type	
Project			
Comments		Date	
Prepared by			

electrical wiring compartment. Integral LED electronic driver incorporates surge protection. 120-277V 50/60Hz or 347V 60Hz models.

Finish

Crosstour is protected with a Super durable TGIC carbon bronze or summit white polyester powder coat paint. Super durable TGIC powder coat paint finishes withstand extreme climate conditions while providing optimal color and gloss retention of the installed life.

Warranty

Five-year warranty.

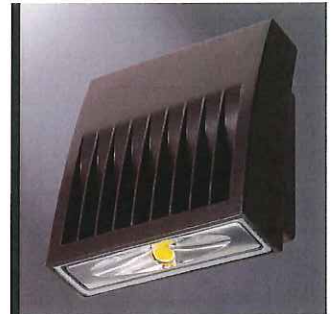

XTOR CROSSTOUR LED

APPLICATIONS:
WALL / SURFACE
POST / BOLLARD
LOW LEVEL
FLOODLIGHT
INVERTED
SITE LIGHTING

DIMENSIONS

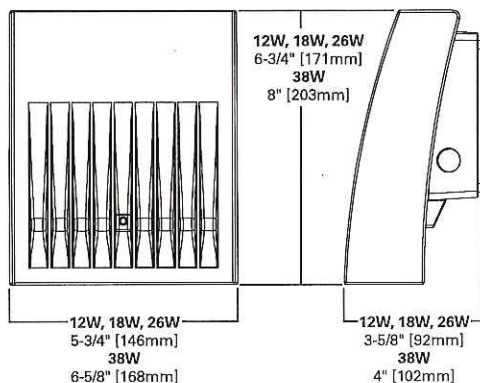

ESCUTCHEON PLATES

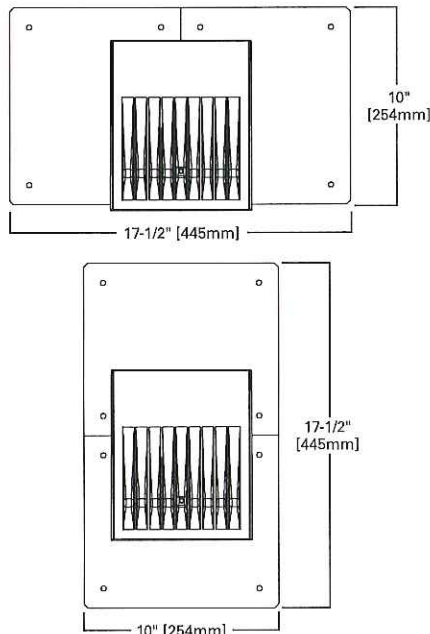

CERTIFICATION DATA

UL/cUL Wet Location Listed
LM79 / LM80 Compliant
ROHS Compliant
ADA Compliant
NOM Compliant Models
IP66 Ingressed Protection Rated
Title 24 Compliant
DesignLights Consortium® Qualified*

TECHNICAL DATA

40°C Maximum Ambient Temperature
External Supply Wiring 90°C Minimum

EPA

Effective Projected Area (Sq. Ft.):
XTOR1B, XTOR2B, XTOR3B=0.34
XTOR4B=0.45

SHIPPING DATA:

Approximate Net Weight:
3.7 – 5.25 lbs. [1.7 – 2.4 kgs.]