

**To:** Brian R. Gilchrist  
The Morgan Group, Inc.

**From:** Jamie Blakeman, PE, PTOE

**Job Number:** 18.1170.001

**RE:** 2nd Street and Bishop Lane  
Traffic Impact & Mitigation Analysis

**Date:** February 27, 2019

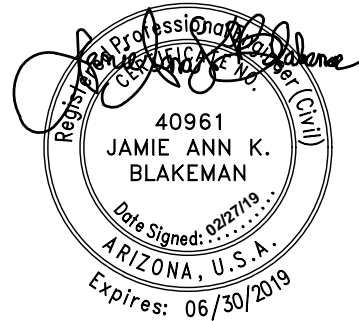

## INTRODUCTION

J2 Engineering and Environmental Design (J2) has prepared a Traffic Statement for the proposed 2nd Street and Bishop Lane residential development located on the southwest corner of 2<sup>nd</sup> Street and Bishop Lane in Old Town Scottsdale. See **Figure 1** for the vicinity map.

The proposed 2nd Street and Bishop Lane development will be comprised of 199 multifamily units in an 8-story development. Of the 199 units, 72 will be studio units, 91 are 1-bedroom units, and 36 are 2- bedroom units. See **Attachment A** and **Figure 2** for the site plan.



**Figure 1 - Vicinity Map**

The objective of this Traffic Statement is to analyze the traffic related impacts of this proposed development to the adjacent roadway network.

## EXISTING CONDITIONS

The proposed development is bordered by 2<sup>nd</sup> Street to the north, Bishop Lane to the east, an alley to the west, and a commercial property to the south.

**2<sup>nd</sup> Street** runs east-west and provides one through lane for each direction of travel. There is a posted speed limit of 25 miles per hour (mph). On-street parallel parking and bike lanes are currently provided on the north and south sides of 2<sup>nd</sup> Street.

**Bishop Lane** runs north-south and provides one through lane for each direction of travel with an unposted speed limit of 25 mph. This roadway connects 2<sup>nd</sup> Street with Goldwater Boulevard and does not extend north or south of these two roadways. On-street parallel parking is provided on the east and west sides of this 600-foot long roadway segment.

The City of Scottsdale does not provide roadway classifications nor traffic volumes for these two roadways.

## COLLISION HISTORY

The most recent 3-year collision history, from January 2015 to December 2017, was obtained from the City of Scottsdale. See **Attachment B** for collision data. The data included the following intersections:

- Goldwater Boulevard and 2<sup>nd</sup> Street
- Marshall Way and 2<sup>nd</sup> Street
- Bishop Lane and 2<sup>nd</sup> Street
- Scottsdale Road and 2<sup>nd</sup> Street
- Bishop Lane and Goldwater Boulevard

### Goldwater Boulevard and 2<sup>nd</sup> Street

During the three year period, there were a total of 36 crashes, of which 1 was an incapacitating injury, 9 were non-incapacitating injuries, 6 were possible injuries, 1 was unknown, with the remaining crashes being property damage only. There were a total of 30 angle, 3 head on, 2 sideswipe same direction, and 1 left turn crashes.

The proposed 2<sup>nd</sup> Street and Bishop Lane development is not anticipated to negatively impact or result in changes to potential collision patterns at this intersection. However, due to the frequency of angle crashes, it is recommended to investigate potential improvements that may reduce these types of crashes. For this two-way stop controlled intersection the angle crashes are mainly occurring when east and westbound stop-controlled drivers attempt to turn onto Goldwater Boulevard. Located on a curve, it is recommended to verify that there is adequate sight distance. Other enhancements to consider may be additional lighting at the intersection, adjusting upstream signal timing to provide adequate gaps,

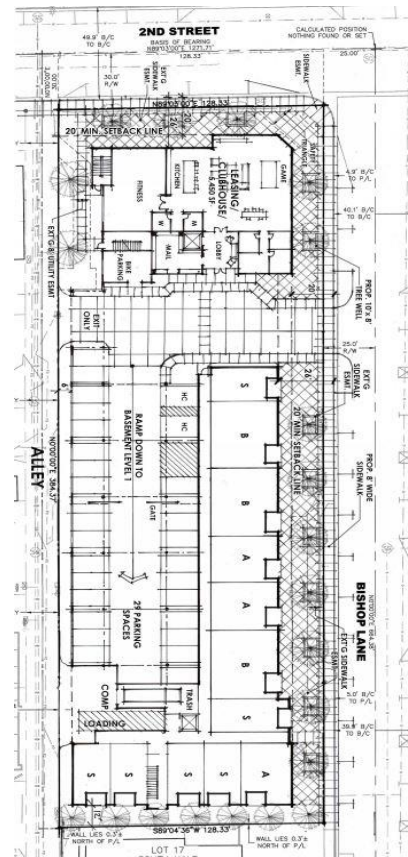

Figure 2 - Site Plan

verifying speeds along Goldwater Boulevard and if necessary implement speed mitigation improvements, etc.

#### Marshall Way and 2<sup>nd</sup> Street

During the three year period, there were a total of 2 crashes, of which 1 was an incapacitating injury, and the other property damage only. Both were angle crashes.

#### Bishop Lane and 2<sup>nd</sup> Street

During the three year period, there was 1 left turn crash, resulting in property damage only.

#### Scottsdale Road and 2<sup>nd</sup> Street

During the three year period, there were a total of 16 crashes, of which 3 were non-incapacitating injuries, 2 were possible injuries, with the remaining crashes being property damage only. There were a total of 8 angle, 5 rear end, 1 single vehicle, 1 sideswipe same direction, and 1 other crashes.

The proposed 2<sup>nd</sup> Street and Bishop Lane development is not anticipated to negatively impact or result in changes to potential collision patterns at this intersection. However, due to the frequency of angle crashes involving southbound vehicles, it is recommended to investigate potential improvements that may reduce these types of crashes. For this signalized intersection five (5) of the eight (8) angle crashes involved southbound vehicles disregarding the traffic signal, and colliding with east and westbound vehicles. It is recommended a study be conducted to potentially address and reduce these types of crashes. This may include evaluating the signal timing yellow and all-red phases, verifying the sight visibility of the existing signal heads, providing an additional traffic signal head for the southbound approach, etc.

#### Bishop Lane and Goldwater Boulevard

During the three year period, there were no crashes reported at this intersection.

## COLLISION RATES

The City of Scottsdale's *2016 Traffic Volume and Collision Rate Data* report provides collision rate and traffic volume information on major roadway segments and at major intersections within the City of Scottsdale. Segment collisions are collisions that occur on a major street more than 100 feet from the major intersections that define the segment, including at minor intersections within the segment. Intersection collisions are collisions that occur at or within 100 feet of a major intersection.

The collision rates and city-wide rankings for the study roadway segments are shown in **Table 1**. The City of Scottsdale's *2016 Traffic Volume and Collision Rate Data* did not report

any data for the five (5) study intersections; therefore, only segment collision rates were reported.

**Table 1 – Collision Rates - Study Roadway Segments**

Segment	From	To	Collision Rate	Rank
Goldwater Boulevard	Scottsdale Road	Indian School Road	8.29	1
2016 City of Scottsdale Average Segment Collision Rate			1.50	

## EXISTING CONDITIONS

### EXISTING TRAFFIC VOLUMES

Existing traffic volumes were collected as part of the Museum Square Traffic Impact and Mitigation Analysis (TI&MA), dated August 10, 2018, the following intersections were collected on Tuesday, September 19, 2017:

- Goldwater Boulevard and 2<sup>nd</sup> Street (1)
- 2<sup>nd</sup> Street and Marshall Way (2)
- Scottsdale Road and 2<sup>nd</sup> Street (3)

The Museum Square TI&MA also included traffic counts collected on Tuesday, March 20, 2018. They include the following intersections:

- Goldwater Boulevard and 70<sup>th</sup> Street (4)
- Goldwater Boulevard and Marshall Way (5)
- Goldwater Boulevard and Scottsdale Road (7)

To supplement the existing traffic counts, traffic volumes were collected on Wednesday, February 20, 2019 and Thursday, February 21, 2019 at the following intersections:

- Goldwater Boulevard and Bishop Lane (6)
- 2<sup>nd</sup> Street and Bishop Lane (8)

See **Figure 3** and for the existing traffic volumes and **Attachment C** for the detailed traffic count data.

### EXISTING CAPACITY ANALYSIS

As reported in the August 10, 2018 Museum Square TI&MA, the existing capacity analysis was completed using the methodology presented in the *2010 Highway Capacity Manual*. The analysis was completed using the traffic software, Synchro Version 9.2. The signal

timing was provided by the City of Scottsdale. See **Attachment D** for existing signal timing as provided in the August 10, 2018 Museum Square TI&MA.

The existing capacity analysis is shown in **Figure 4**. The detailed capacity analysis sheets can be found in **Attachment E**. The analysis for all intersection are reported directly from the Museum Square TI&MA, dated August 10, 2018, with the exception of Bishop Lane and 2nd Street (8) and Bishop Lane and Goldwater Boulevard (6).

The results of the capacity analyses reveal the following locations with an existing level of service (LOS) E or F:

### **Goldwater Boulevard and Scottsdale Road (7) – Signalized**

- EB left AM peak hour operates at LOS E
- EB shared through-right AM peak hour operates at LOS E

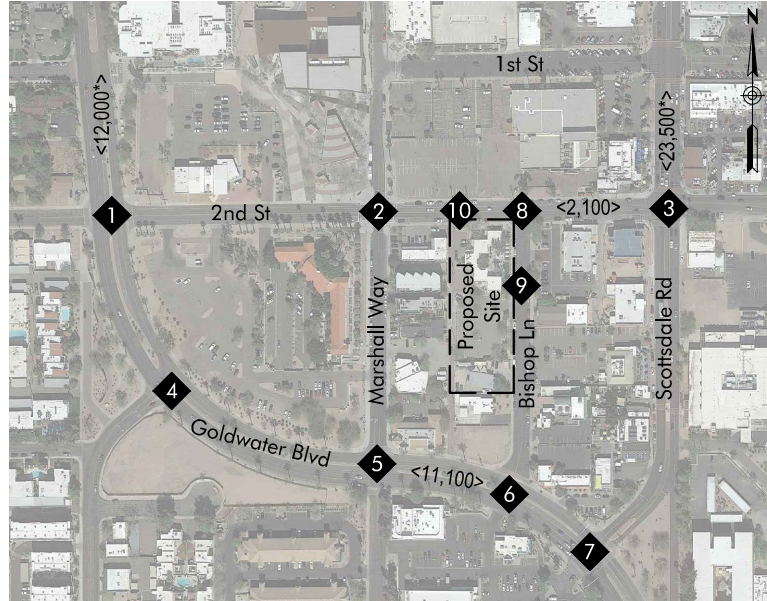
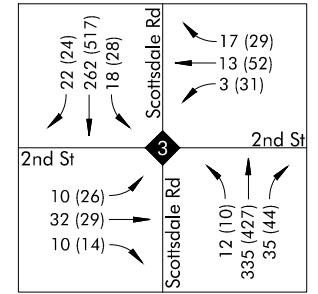
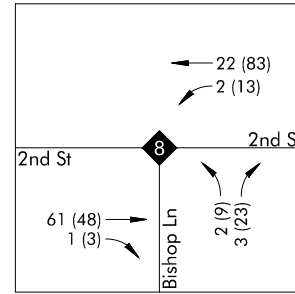
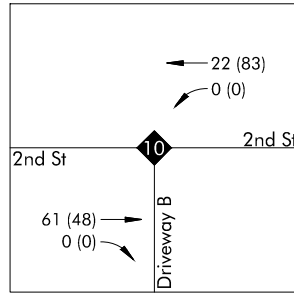
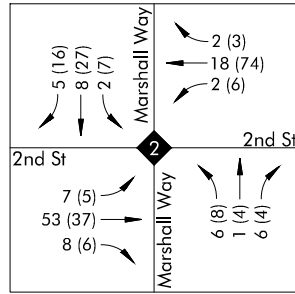
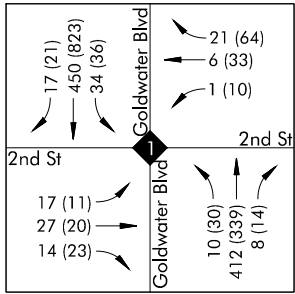

Legend

- AM (PM) Existing Peak Hour Traffic Volumes
- ◆ Intersection
- <ADT> Average Daily Traffic Volumes
- \* ADT obtained from City of Scottsdale 2016 Segment Traffic Volumes

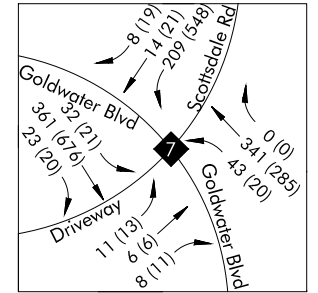
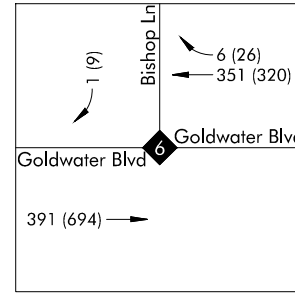
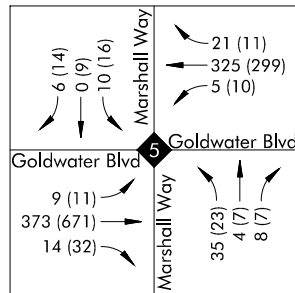
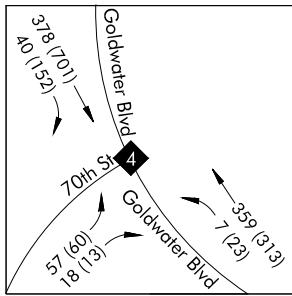
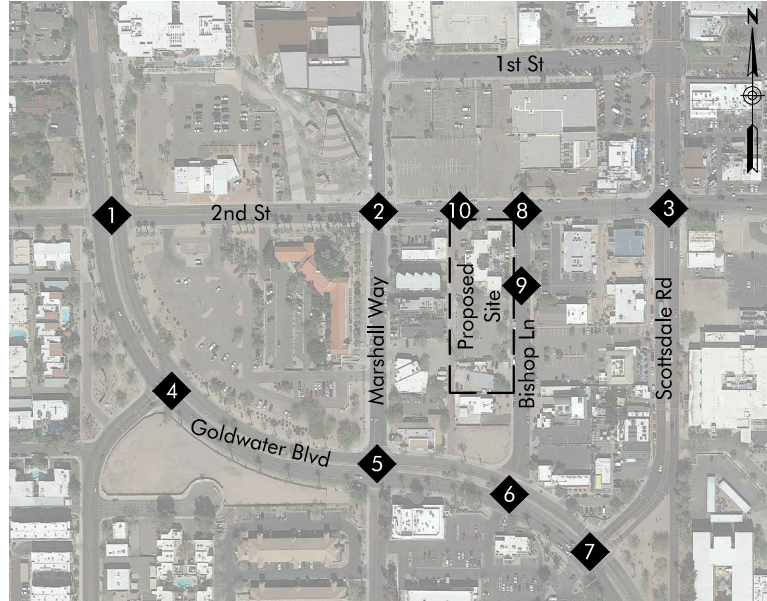
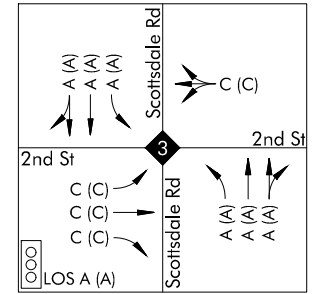
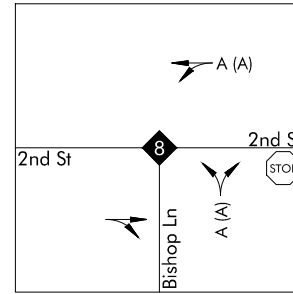
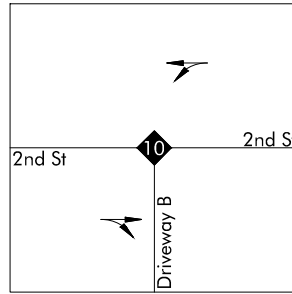
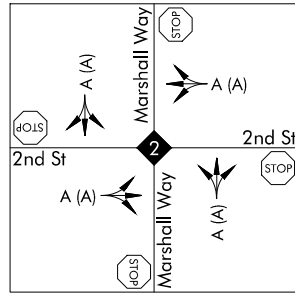
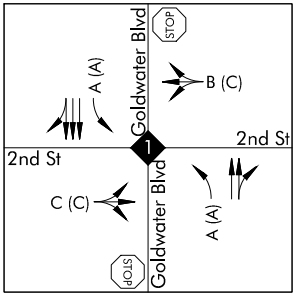

FIGURE 3 | EXISTING TRAFFIC VOLUMES



Legend

- AM (PM) Existing Peak Hour Capacity Analysis (HCM Methodology)
- AM\* (PM)\* Existing Peak Hour Capacity Analysis (Synchro Methodology)
- Intersection
- Lane Configuration

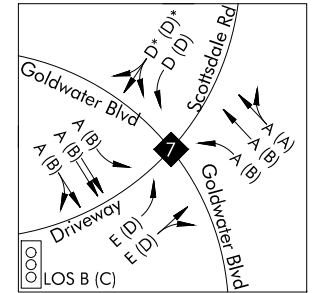
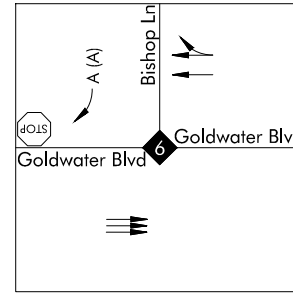
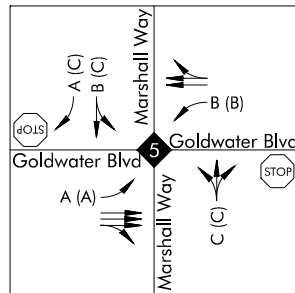
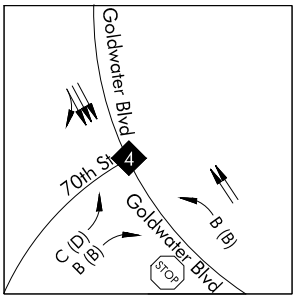

FIGURE 4 | EXISTING CAPACITY ANALYSIS

## TRIP GENERATION

### EXISTING LAND USE

The proposed site is comprised of five parcels (130-13-025A, 130-13-027, 130-13-028, 130-13-029, 130-13-030A). Currently, these parcels are zoned for C-3 (Highway Commercial District) land use and the combined lot size is 49,330 square feet (SF). See **Attachment F** for detailed parcel information.

According to the Maricopa County Assessor's website, lot 130-13-025A contains 1,666 SF of retail space, lot 130-13-30A contains 5,120 SF of restaurant space, and the remaining three parcels are parking lots.

The trip generation for the existing land uses was calculated utilizing the Institute of Transportation Engineers (ITE) publication entitled *Trip Generation, 10th Edition*. The ITE rates are based on studies that measured the trip generation characteristics for various types of land uses. The rates are expressed in terms of trips per unit of land use type. This publication is considered to be the standard for the transportation engineering profession.

Utilizing ITE Land Use 932 High-Turnover (Sit-Down) Restaurant and ITE Land Use 820 Shopping Center, the trip generation for the existing land uses was calculated as shown in **Table 2** below. See **Attachment G** for detailed trip generation calculations.

**Table 2 - Trip Generation - Existing Land Use**

Land Use	ITE Code	Qty	Unit	Weekday	AM Peak Hour			PM Peak Hour		
				Total	Total	In	Out	Total	In	Out
Shopping Center	820	1.7	1000 SF GLA	371	153	95	58	26	13	13
High-Turnover (Sit-Down) Restaurant	932	5.1	1000 SF GFA	574	51	28	23	50	31	19
<b>Total</b>				<b>945</b>	<b>204</b>	<b>123</b>	<b>81</b>	<b>76</b>	<b>44</b>	<b>32</b>

### EXISTING ZONING

The five (5) parcels are currently zoned for C-3 (Highway Commercial District). Permitted uses within the C-3 (Highway Commercial District) zoning district allow for most types of commercial development including retail, general office, and services. With a total lot area of 49,330 SF (1.13 acres), and a maximum floor-to-area ratio (FAR) of 0.80, a 39,464 SF retail space was assumed as a reasonable buildout on this site under the existing C-3 commercial zoning.

ITE Land 820 Shopping Center was utilized. The total trip generation for the buildout of the site under the existing zoning was calculated as shown in **Table 3** below. See **Attachment G** for detailed trip generation calculations.

Table 3 - Trip Generation - Existing Zoning Buildout

Land Use	ITE Code	Qty	Unit	Weekday Total	AM Peak Hour			PM Peak Hour		
					Total	In	Out	Total	In	Out
Shopping Center	820	39.5	1000 SF GLA	3,195	172	107	65	273	132	141

### PROPOSED DEVELOPMENT

The proposed 2nd Street and Bishop Lane residential development will consist of 199 units built as an eight-story multifamily complex. Of the 199 units, 72 will be studio units, 91 are one (1) bedroom units, and 36 are two (2) bedroom units. A vehicular access into the parking garage will be located along Bishop Lane approximately 150 feet south of 2<sup>nd</sup> Street. An egress only driveway will be located along the alley approximately 150 south of 2<sup>nd</sup> Street.

**ITE Land Use 221** – Multifamily Housing (Mid-Rise) was used to calculate the trips generated by this eight-story proposed multifamily development. The total trip generation for the proposed 2nd Street and Bishop Lane site is shown in **Table 2** below. Detailed trip generation calculations are provided in **Attachment G**.

Table 4 – Trip Generation - Proposed Development

Land Use	ITE Code	Qty	Unit	Weekday Total	AM Peak Hour			PM Peak Hour		
					Total	In	Out	Total	In	Out
Multifamily Housing (Mid-Rise)	221	199	Dwelling Units	1,083	67	17	50	86	52	34

### TRIP GENERATION COMPARISON

A comparison between trips generated by the existing land use versus the proposed 199 residential unit 2nd Street and Bishop Lane development is shown in **Table 5**.

Table 5 – Trip Generation Comparison (Existing Land Use vs. Proposed Development)

Land Use	ITE Code	Qty	Unit	Weekday Total	AM Peak Hour			PM Peak Hour		
					Total	In	Out	Total	In	Out
Shopping Center	820	1.7	1000 SF GLA	371	153	95	58	26	13	13
High-Turnover (Sit-Down) Restaurant	932	5.1	1000 SF GFA	574	51	28	23	50	31	19
<b>Total Existing Land Use</b>				<b>945</b>	<b>204</b>	<b>123</b>	<b>81</b>	<b>76</b>	<b>44</b>	<b>32</b>
Multifamily Housing (Mid-Rise)	221	199	Dwelling Units	1,083	67	17	50	86	52	34
<b>Total Proposed</b>				<b>1,083</b>	<b>67</b>	<b>17</b>	<b>50</b>	<b>86</b>	<b>52</b>	<b>34</b>
<b>Difference</b>				<b>138</b>	<b>-137</b>	<b>-106</b>	<b>-31</b>	<b>10</b>	<b>8</b>	<b>2</b>

The proposed 2nd Street and Bishop Lane residential development is expected to generate 138 additional weekday daily trips, 137 fewer AM peak hour trips, and 10 additional PM peak hour trips compared to the existing retail and restaurant land uses.

A trip generation comparison between the trips generated under the build out of the existing zoning versus the proposed 199 residential unit 2nd Street and Bishop Lane development is shown in **Table 6**.

**Table 6 – Trip Generation Comparison (Existing Zoning vs. Proposed Development)**

Land Use	ITE Code	Qty	Unit	Weekday	AM Peak Hour			PM Peak Hour		
				Total	Total	In	Out	Total	In	Out
Shopping Center	820	39.5	1000 SF GLA	3,195	172	107	65	273	132	141
<b>Total Existing Land Use</b>				3,195	172	107	65	273	132	141
Multifamily Housing (Mid-Rise)	221	199	Dwelling Units	1,083	67	17	50	86	52	34
<b>Total Proposed</b>				1,083	67	17	50	86	52	34
<b>Difference</b>				-2,112	-105	-90	-15	-187	-80	-107

The proposed 2nd Street and Bishop Lane residential development is expected to generate 2,112 fewer weekday daily trips, 105 fewer AM peak hour trips, and 187 fewer PM peak hour trips compared to the build out of a possible retail use allowed under the existing zoning.

**TRIP DISTRIBUTION AND ASSIGNMENT**

The trip distribution procedure determines the general pattern of travel for vehicles entering and leaving the proposed development. The trip distribution for the proposed 2nd Street and Bishop Lane residential development is based on the distribution of the existing traffic. This project is being developed in an urban area, so it can be assumed that the travel patterns are well established and the existing trip distribution applies to future development. The trip distribution is shown in **Figure 5**.

The trip assignment was generally based on proximity of the driveways, permitted turn movement, as well as ease of probability of use. The site generated traffic volumes are shown in **Figure 6**.

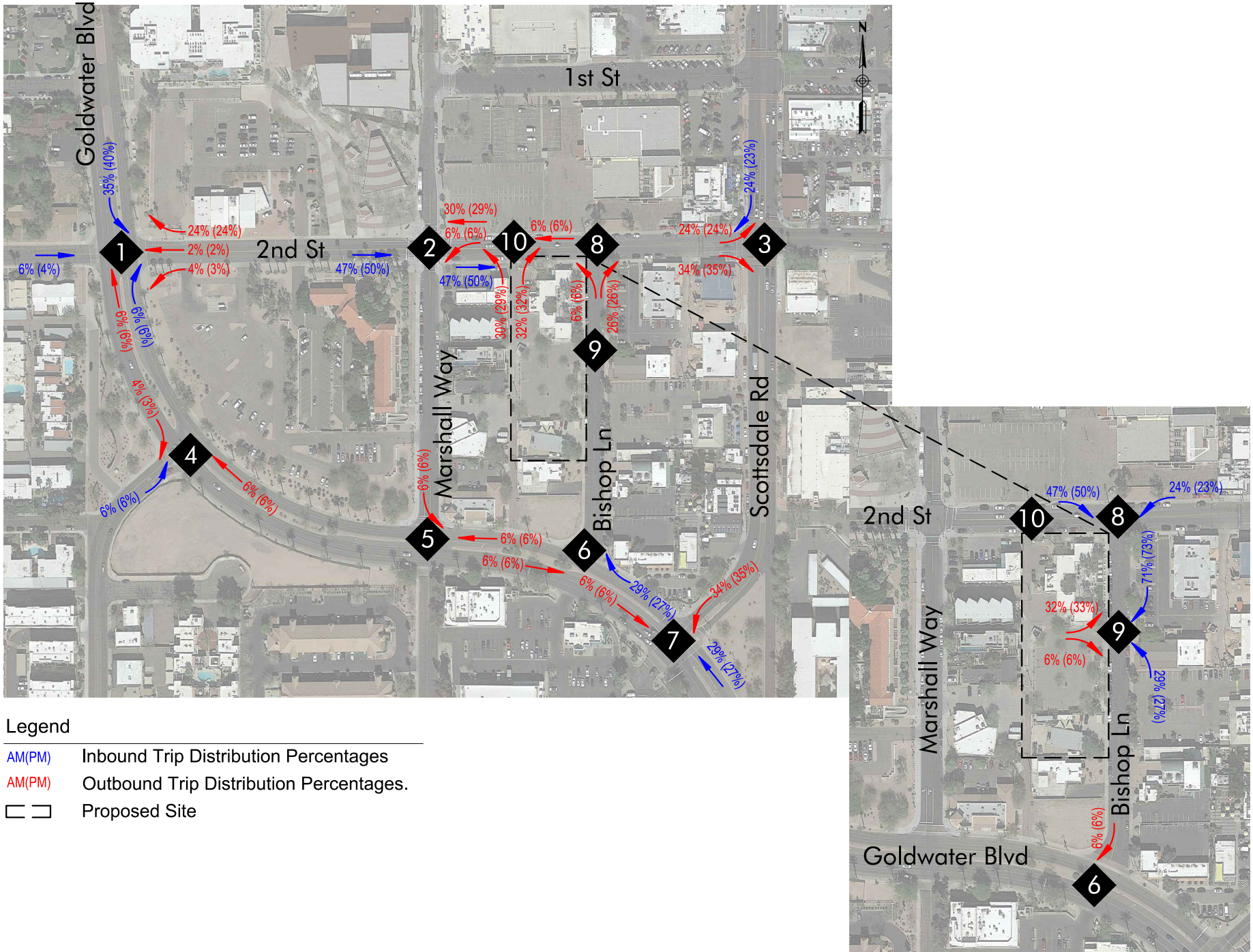
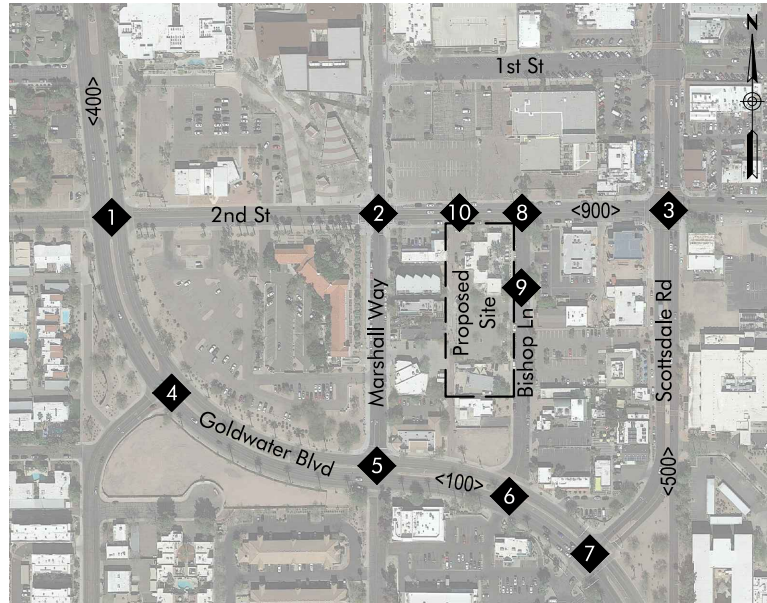
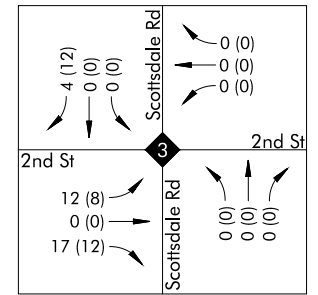
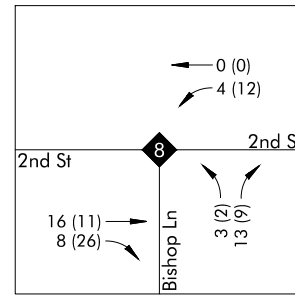
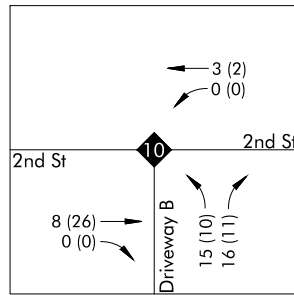
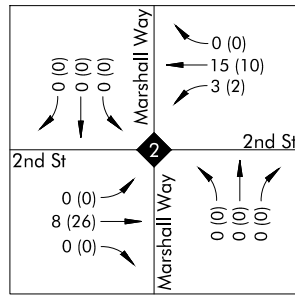
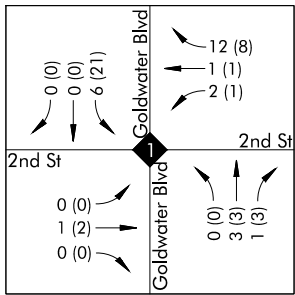

FIGURE 5 | TRIP DISTRIBUTION



Legend

- AM (PM) Site Peak Hour Traffic Volumes
- ◆ Intersection
- <ADT> Average Daily Traffic Volumes

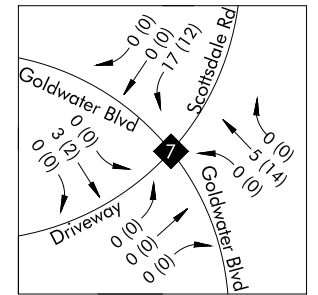
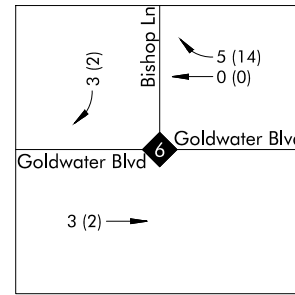
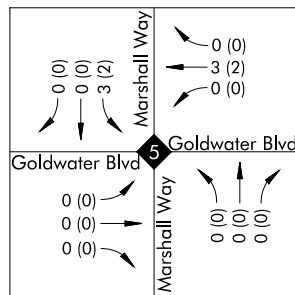
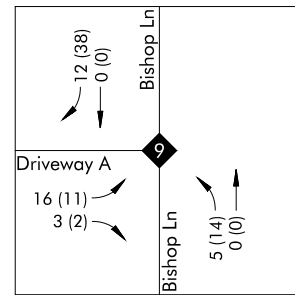
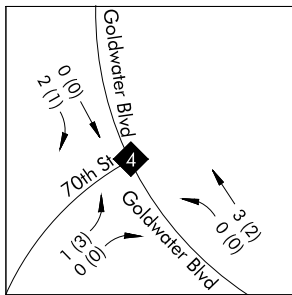

FIGURE 6 | 2ND STREET AND BISHOP LANE SITE TRAFFIC VOLUMES

## YEAR 2025 CONDITIONS

### YEAR 2025 NO BUILD TRAFFIC VOLUMES

The proposed Museum Square development is anticipated to be build out in year 2025, therefore is included as part of the background traffic volumes for year 2025. See **Figure 7** for the Museum Square site traffic volumes as reported in the Museum Square TI&MA, dated August 10, 2018.

The traffic volumes of known future developments were added and distributed throughout the studied roadway network. These developments include, Canopy by Hilton, and The Goldwater. Additionally, a 1.0% annual growth rate was conservatively applied along Goldwater Boulevard through year 2025. See **Figure 8** for the year 2025 background traffic volumes (without Museum Square).

Adding the Museum Square site traffic volumes (**Figure 7**) to the year 2025 background traffic volumes (**Figure 8**) results in the total year 2025 no build traffic volumes. The traffic volumes shown in **Figure 9** includes the 1.0% annual background growth, and the build out of Museum Square, Canopy by Hilton, and The Goldwater developments.

### YEAR 2025 BUILD PEDESTRIAN VOLUMES

The proposed Museum Square development intends on attracting and promoting walkability within the surrounding area. Therefore, an increase in pedestrian volumes were accounted for at the intersections of Goldwater Boulevard and 2<sup>nd</sup> Street (12) and Scottsdale Road and 2<sup>nd</sup> Street (17).

Using the City of Scottsdale's *Design Standards & Policies Manual*, Figure 5-1.2 Level of Service Default Data, the "moderate" level of pedestrian volumes were incorporated into the year 2025 build capacity analyses. See **Attachment H**. Therefore, a volume of 200 pedestrians per hour were used for the crossings of each leg of the intersections of Goldwater Boulevard and 2<sup>nd</sup> Street (12) and Scottsdale Road and 2<sup>nd</sup> Street (17).

### YEAR 2025 NO BUILD CAPACITY ANALYSIS

It should be noted that per the August 10, 2018 Museum Square TI&MA, the following intersection improvements were noted for the year 2025 no build analysis:

#### *Goldwater Boulevard and 2<sup>nd</sup> Street (1) – Signalized*

The City of Scottsdale has considered the installation of a traffic signal at this intersection to support bicycle and pedestrian connections, and address requests from area merchants and residents. Additionally, the City of Scottsdale has also considered the installation of a pedestrian hybrid beacon along Goldwater Boulevard approximately 300 feet west of Marshall Way to assist with pedestrian and bicycle crossings.

Therefore, the year 2025 no build capacity analysis was completed with a traffic signal at the intersection of Goldwater Boulevard and 2nd Street (1). See **Figure 10** for the results of the year 2025 no build capacity analysis. The detailed capacity analysis sheets can be found in **Attachment I**.

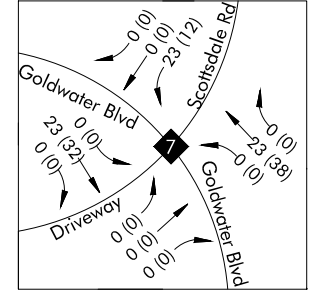
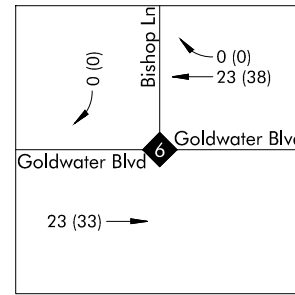
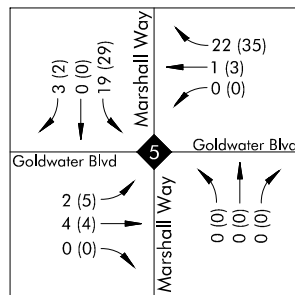
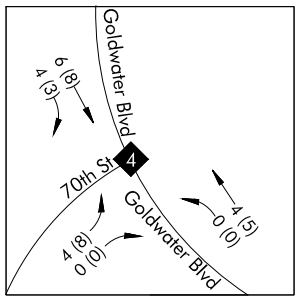
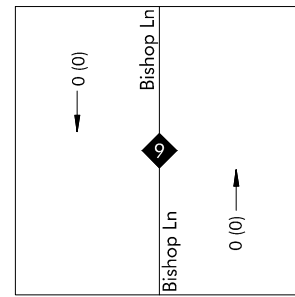
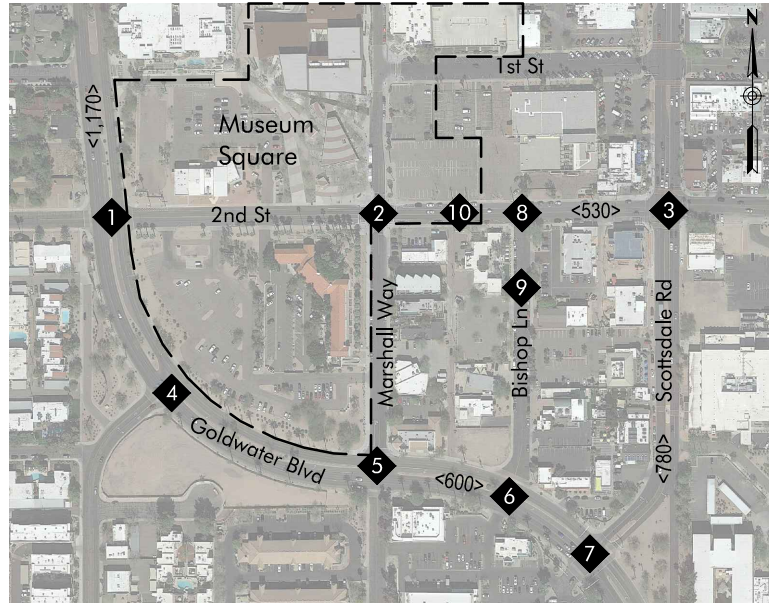
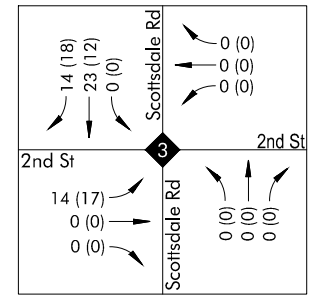
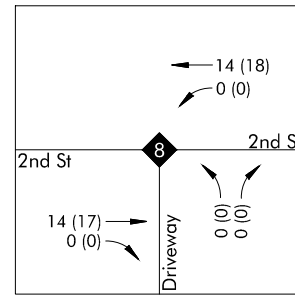
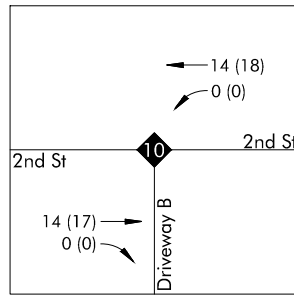
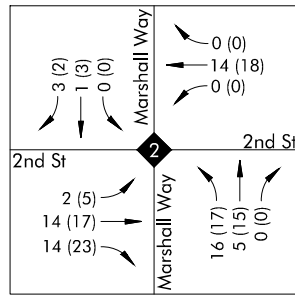
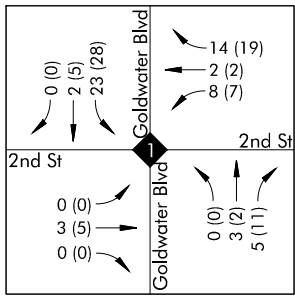
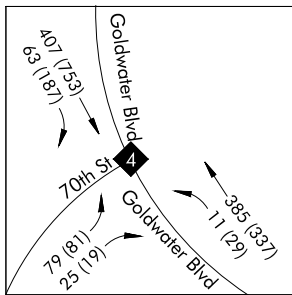
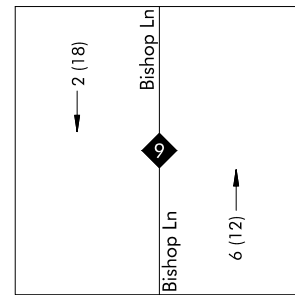
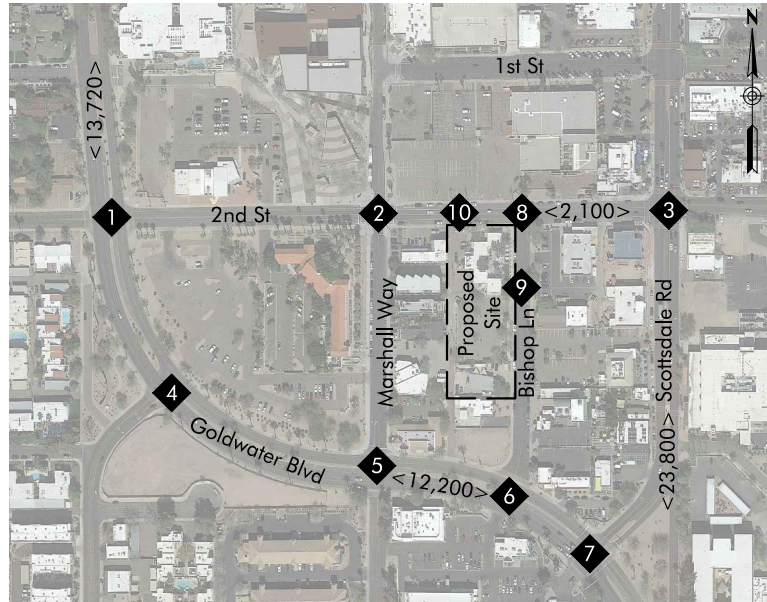
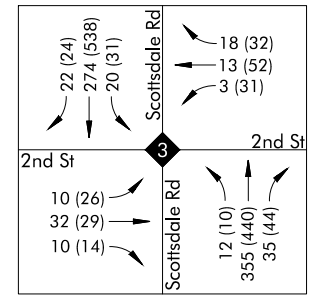
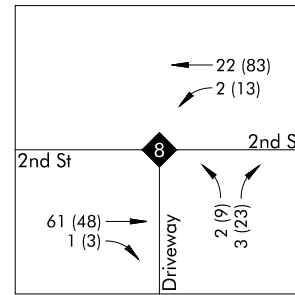
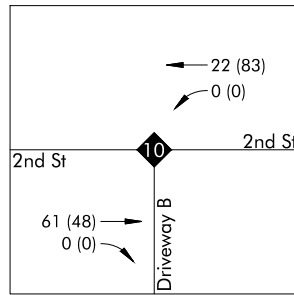
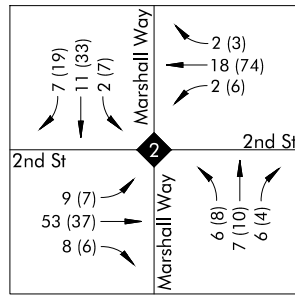
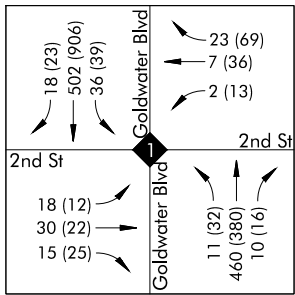

FIGURE 7 | MUSEUM SQUARE SITE TRAFFIC VOLUMES



Legend  
 AM (PM) Year 2025 Background Peak Hour Traffic Volumes  
 ♦ Intersection  
 <ADT> Average Daily Traffic Volumes

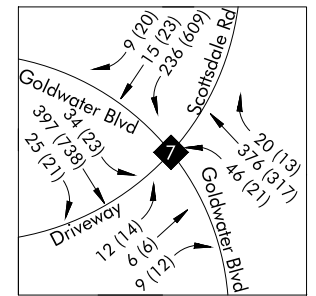
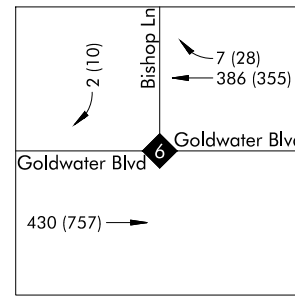
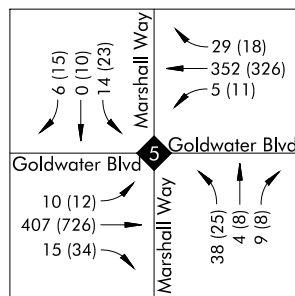
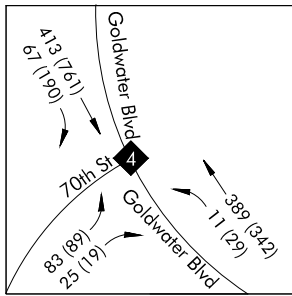
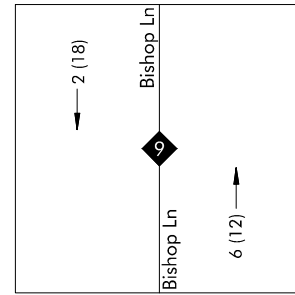
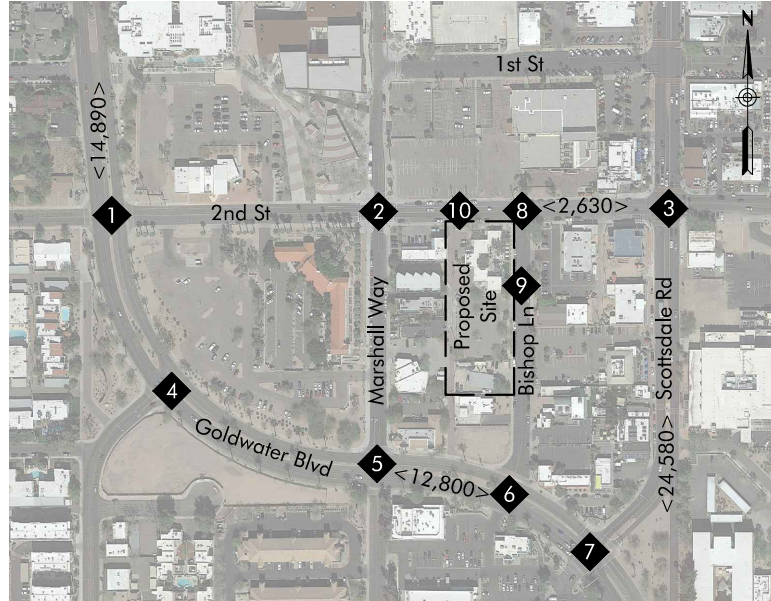
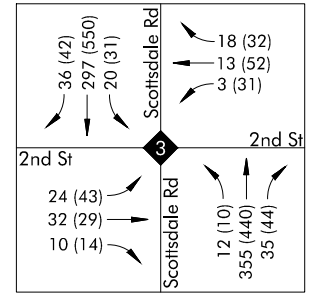
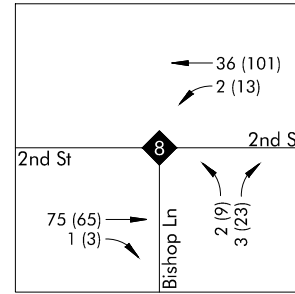
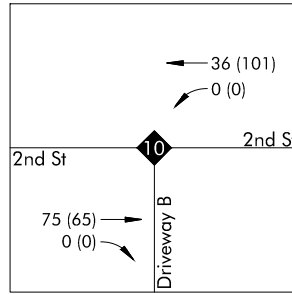
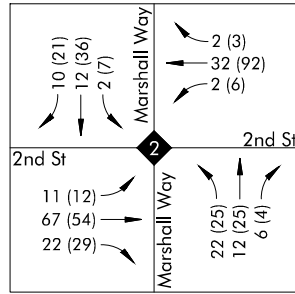
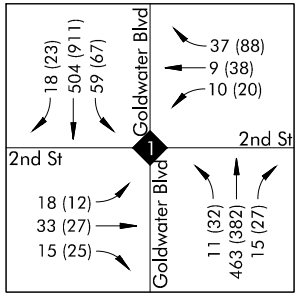

FIGURE 8 | YEAR 2025 BACKGROUND TRAFFIC VOLUMES (WITHOUT MUSEUM SQUARE)



- Legend
- AM (PM) Year 2025 No Build Peak Hour Traffic Volumes
  - Intersection
  - <ADT> Average Daily Traffic Volumes

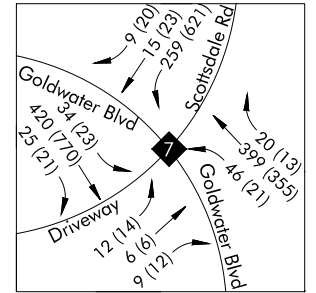
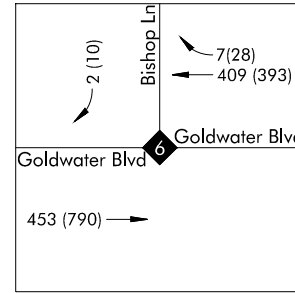
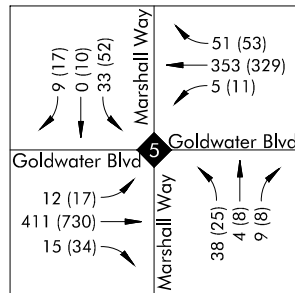
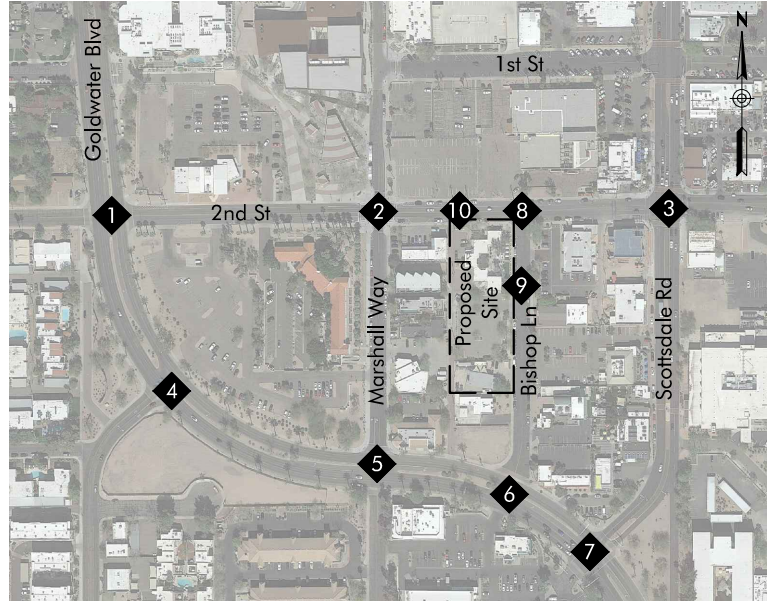
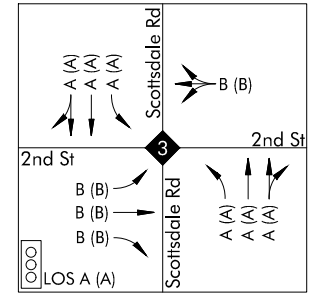
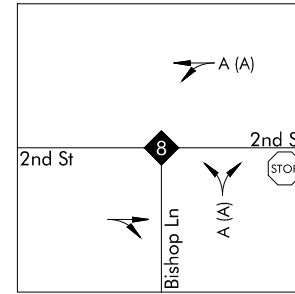
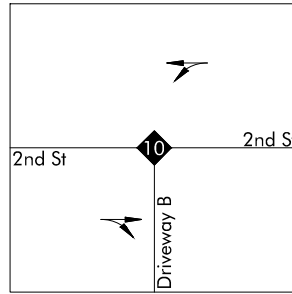
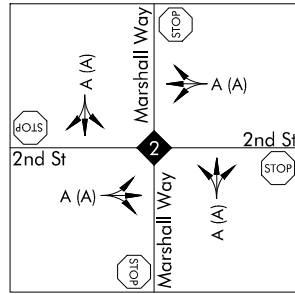
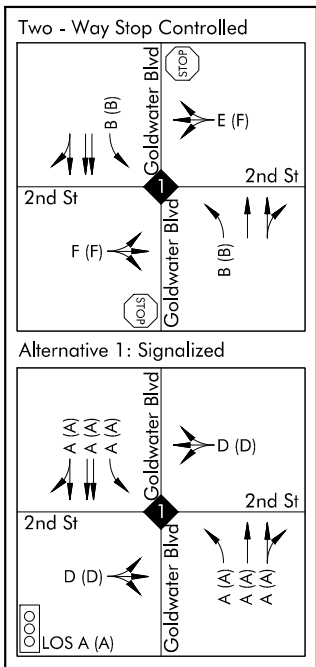
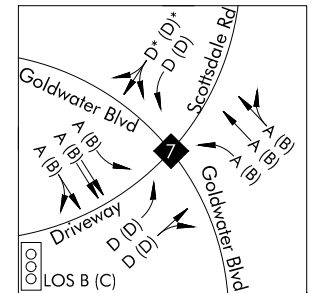
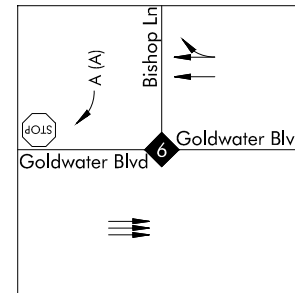
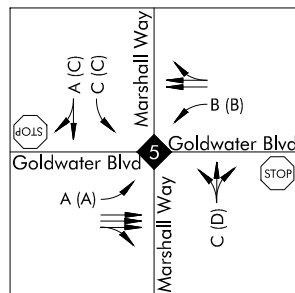
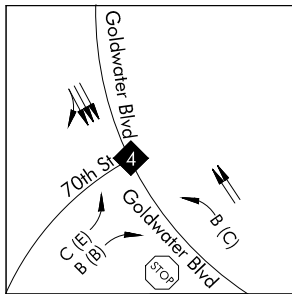

FIGURE 9 | YEAR 2025 NO BUILD TRAFFIC VOLUMES



- Legend**
- AM (PM) 2025 No Build Peak Hour Capacity Analysis (HCM Methodology)
  - AM\* (PM)\* 2025 No Build Peak Hour Capacity Analysis (Synchro Methodology)
  - ◆ Intersection
  - ↔ Lane Configuration



**FIGURE 10 | YEAR 2025 NO BUILD CAPACITY ANALYSIS**

### YEAR 2025 BUILD TRAFFIC VOLUMES

The proposed 2<sup>nd</sup> Street and Bishop Lane residential development is scheduled to be completed by the year 2022. When the 2<sup>nd</sup> Street and Bishop Lane site traffic volumes (**Figure 6**) is added to the year 2025 no build traffic volumes (**Figure 9**), the result is the year 2025 build traffic volumes (**Figure 11**). This represents the traffic volumes with the build out of the proposed 2<sup>nd</sup> Street and Bishop Lane development as well as other nearby surrounding developments.

### YEAR 2025 BUILD CAPACITY ANALYSIS

The year 2025 build capacity analysis included the recommendations that were included in the in the August 10, 2018 Museum Square TI&MA. This includes installing a signal at the intersection of Goldwater Boulevard and 2<sup>nd</sup> Street.

The results of the year 2025 build capacity analysis is shown in **Figure 12**. The detailed capacity analysis sheets can be found in **Attachment I**.

With the build out of the proposed 2<sup>nd</sup> Street and Bishop Lane residential development, all peak hour movements operate at a LOS D or better or are maintained at the no build LOS.

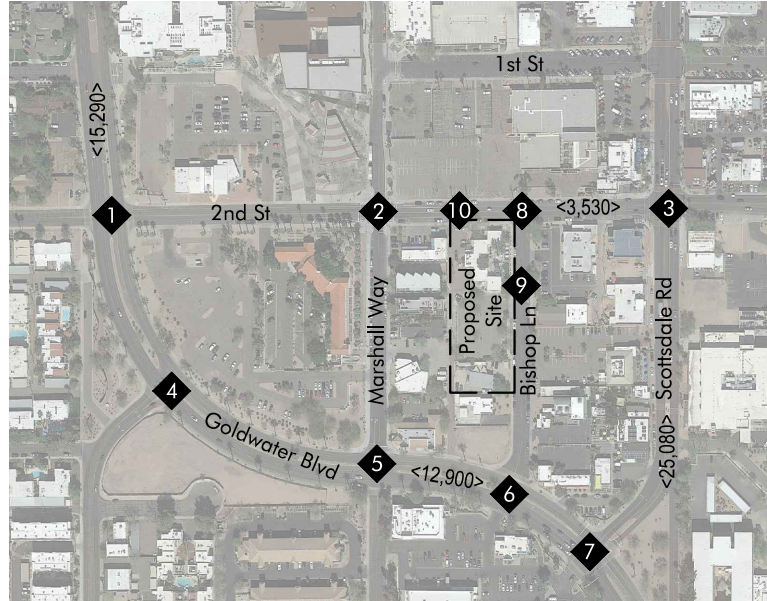
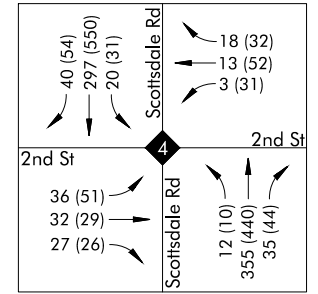
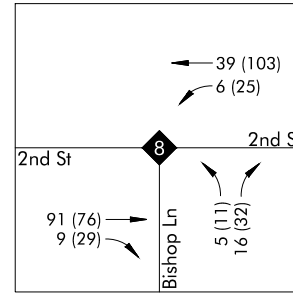
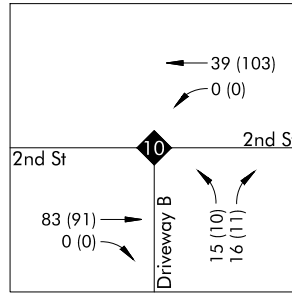
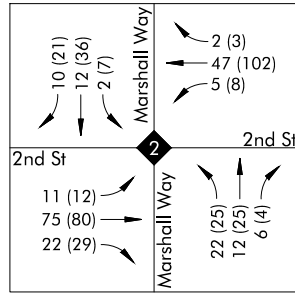
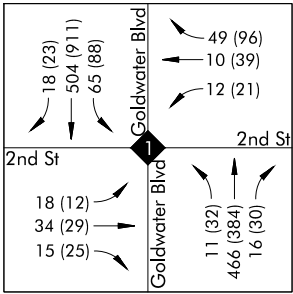

Legend

AM (PM) Year 2025 Build Peak Hour Traffic Volumes

Intersection

<ADT> Average Daily Traffic Volumes

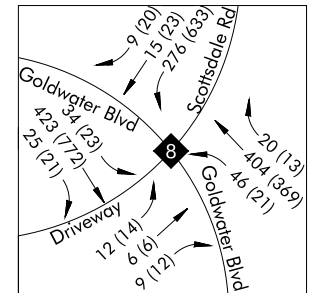
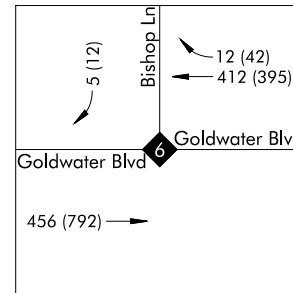
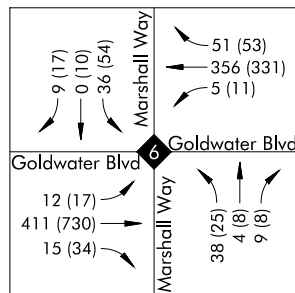
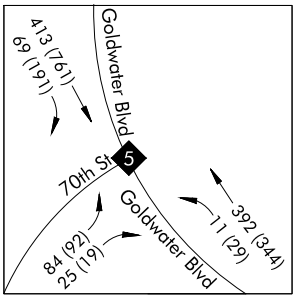
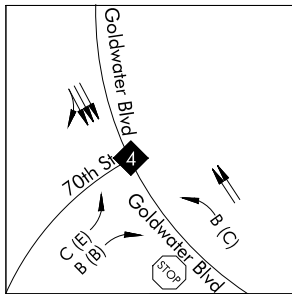
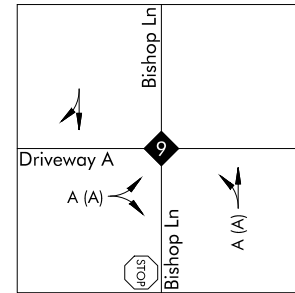
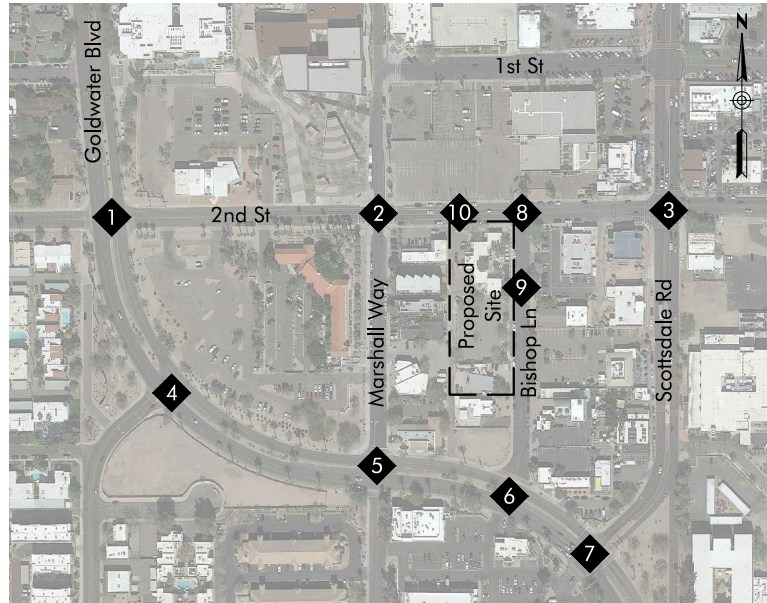
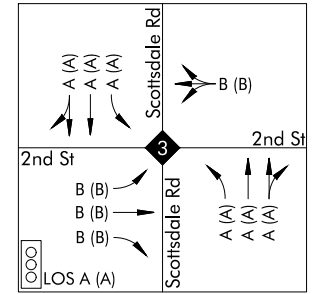
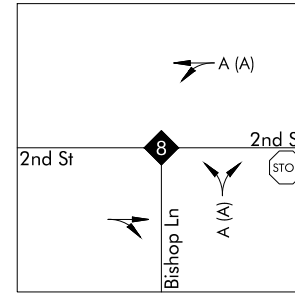
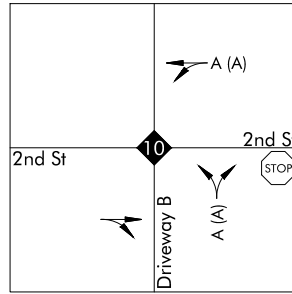
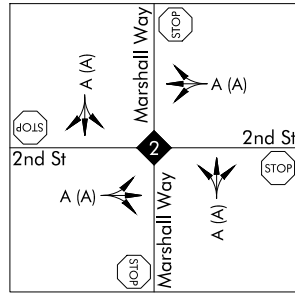
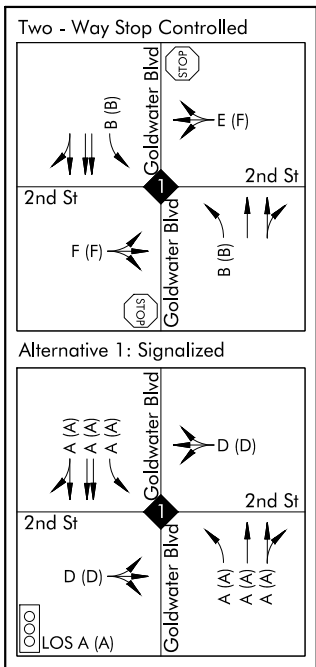
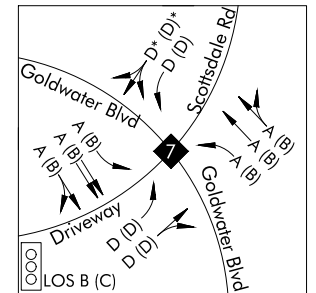
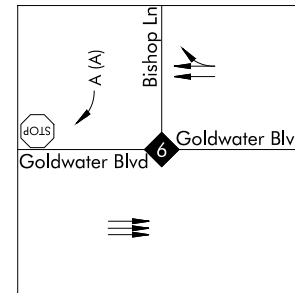
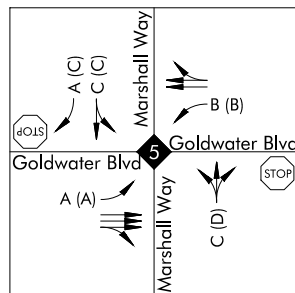

FIGURE 11 | YEAR 2025 BUILD TRAFFIC VOLUMES



**Legend**

- AM (PM) 2025 Build Peak Hour Capacity Analysis (HCM Methodology)
- AM\* (PM)\* 2025 Build Peak Hour Capacity Analysis (Synchro Methodology)
- ◆ Intersection
- ↔ Lane Configuration



**FIGURE 12 | YEAR 2025 BUILD CAPACITY ANALYSIS**

## SUMMARY

The proposed 2<sup>nd</sup> Street and Bishop Lane residential development is located on the southwest corner of 2<sup>nd</sup> Street and Bishop Lane. It will be comprised of 199 residential units. Of the 199 units, 72 will be studio units, 91 are 1-bedroom units, and 36 are 2-bedroom units.

### Existing Capacity Analysis

The AM and PM peak hour existing conditions capacity analysis were completed for the existing study intersections. The following intersection currently operates with movements of a Level of Service E or F:

#### Goldwater Boulevard and Scottsdale Road (7) – Signalized

- EB left AM peak hour operates at LOS E
- EB shared through-right AM peak hour operates at LOS E

### Trip Generation

The proposed 2<sup>nd</sup> Street and Bishop Lane residential development is anticipated to generate 1,083 weekday trips, with 67 trips occurring during the AM peak hour and 86 trips occurring during the PM peak hour.

### Trip Generation Comparison

A comparison between the trips generated by the build out under the existing zoning with a 39,464 square foot retail center versus the proposed 2<sup>nd</sup> Street and Bishop Lane residential development was calculated.

**Trip Generation Comparison (Existing Zoning vs. Proposed)**

Land Use	ITE Code	Qty	Unit	Weekday Total	AM Peak Hour			PM Peak Hour		
					Total	In	Out	Total	In	Out
Shopping Center	820	39.5	1000 SF GLA	3,195	172	107	65	273	132	141
<b>Total Existing Land Use</b>				3,195	172	107	65	273	132	141
Multifamily Housing (Mid-Rise)	221	199	Dwelling Units	1,083	67	17	50	86	52	34
<b>Total Proposed</b>				1,083	67	17	50	86	52	34
<b>Difference</b>				-2,112	-105	-90	-15	-187	-80	-107

The proposed 2<sup>nd</sup> Street and Bishop Lane residential development is expected to generate 2,112 (195%) fewer weekday daily trips, 105 (157%) fewer AM peak hour trips, and 187 (217%) fewer PM peak hour trips compared to the build out of a possible retail use allowed under the existing zoning.

### Future Conditions

Year 2025 analyses were completed without the build out, as well as with the build out of the proposed development. An annual growth rate of 1.0% was applied along Goldwater Boulevard as noted in the August 10, 2018 TI&MA. Additionally, traffic volumes of known developments within the proposed study area were included. This includes, Museum Square, Canopy by Hilton, and The Goldwater developments.

### Year 2025

Capacity analyses were completed for both the AM and PM peak hours for the year 2025, without the build out, as well as with the build out of the proposed 2<sup>nd</sup> Street and Bishop Lane residential development. Under both analyses, all peak hour movements operate at a LOS D or better, or are maintained at the no build level of service.

**In conclusion, the proposed 2nd Street and Bishop Lane development is anticipated to have minimal traffic related impacts to the surrounding roadway network, and significantly less impact to the traffic operation than the potential build out under the existing zoning.**

# ATTACHMENT A – PROPOSED SITE PLAN

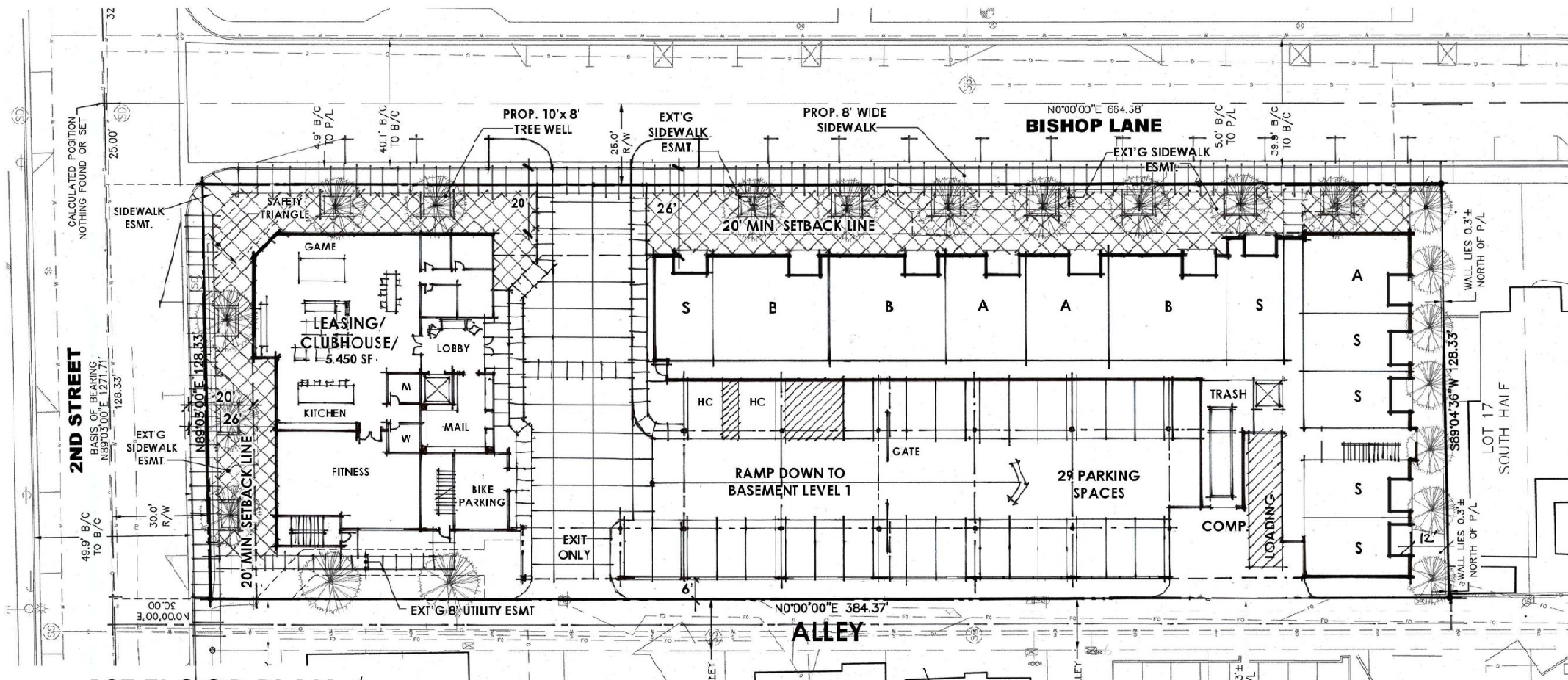

# PROJECT DATA

**SITE AREA:**  
 NET AREA: ± 1.13 ACRES  
 GROSS AREA: ± 1.54 ACRES

**ZONING:**  
 EXISTING: HIGHWAY COMMERCIAL, DOWNTOWN OVERLAY (C-3, DO)  
 PROPOSED: DOWNTOWN/DOWNTOWN MULTIPLE USE TYPE-3, PLANNED BLOCK DEVELOPMENT, DOWNTOWN OVERLAY (DDMU-3, PED, DO)

**HEIGHT:**  
 ALLOWED: 84'  
 PROPOSED: PODIUM AND 7 STORIES ABOVE OR 85' MAX.

**UNIT MIX:**

UNIT TYPE	NO.	%
S-STUDIO	53 D.U.	
S1-STUDIO	2 D.U.	
S2-STUDIO	6 D.U.	
S3-STUDIO	5 D.U.	
S4-STUDIO	4 D.U.	
S5-STUDIO	2 D.U.	
<b>TOTAL STUDIO</b>	<b>72 D.U.</b>	<b>36%</b>

UNIT TYPE	NO.	%
A-1 BEDROOM/1 BATH	27 D.U.	
A1-1BEDROOM/1 BATH/DEN	44 D.U.	
A2-1BEDROOM/1 BATH/DEN	20 D.U.	
<b>TOTAL 1 BEDROOM</b>	<b>91 D.U.</b>	<b>46%</b>

UNIT TYPE	NO.	%
B-2 BEDROOM/2 BATH	27 D.U.	
E1-2 BEDROOM/2 BATH	2 D.U.	
B2-2 BEDROOM/2 BATH/DEN	7 D.U.	
<b>TOTAL 2 BEDROOM</b>	<b>36 D.U.</b>	<b>18%</b>

**TOTAL UNIT:** 199 D.U.  
**NET RENTABLE AREA:** 164,142 SF  
**AVERAGE UNIT NET AREA:** 825 SF

**DENSITY:**  
 ALLOWED: ± 50 D.U./GROSS ACRE  
 PROVIDED: ± 129 D.U./GROSS ACRE

**PARKING:**  
 PARKING REQUIRED:  
 STUDIO 72 D.U.x1.0 P.S./D.U. = 72 P.S.  
 1 BEDROOM/1 BATH 91 D.U.x1.0 P.S./D.U. = 91 P.S.  
 2 BEDROOM/2 BATH 36 D.U.x2.0 P.S./D.U. = 72 P.S.  
 SUB-TOTAL: 235 P.S. (@ 1.18 P.S./D.U.)

**PARKING PROVIDED:**  
 20 LEVEL BASEMENT PARKING: 247 P.S.  
 TOTAL PROVIDED: 247 P.S. (@ 1.24 P.S./D.U.)

**OPTION:**  
 ADDITIONAL 1/2 LEVEL DOWN: 40 P.S.  
 TOTAL PROVIDED: 287 P.S. (@ 1.44 P.S./D.U.)

**GENERAL PARKING DIMENSIONS:**  
 PARKING SPACE 9' x 18'  
 AISLE WIDTH 24'

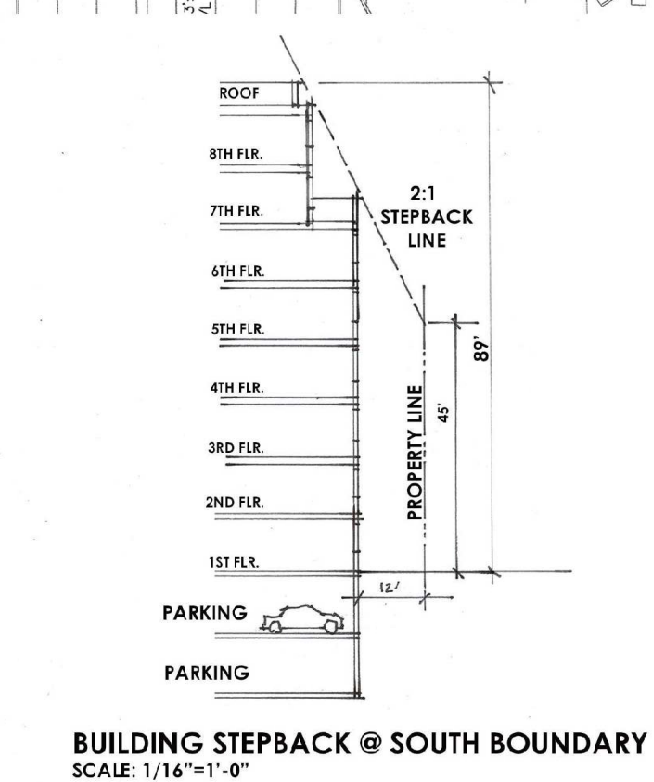
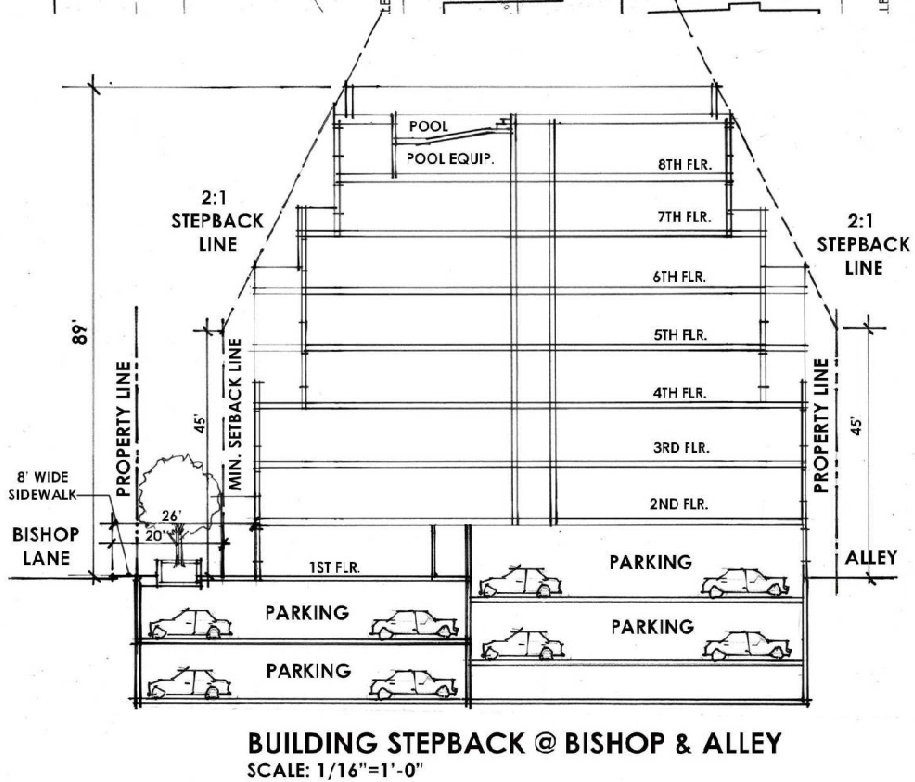
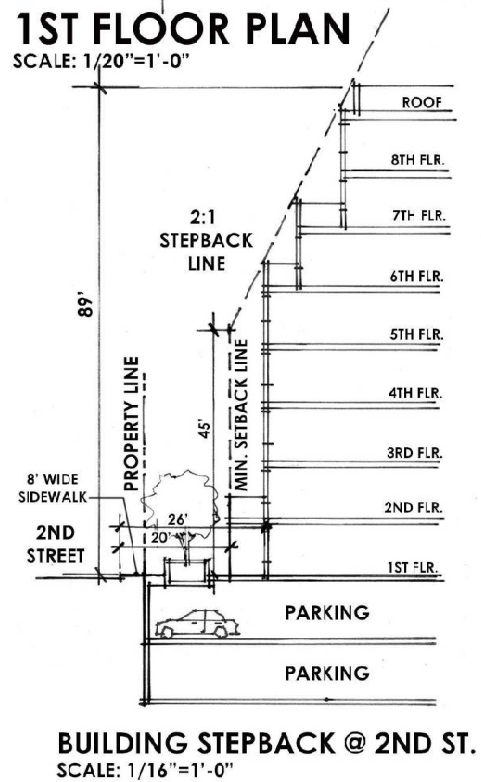

## CONCEPTUAL SITE PLAN

# 2ND STREET AND BISHOP

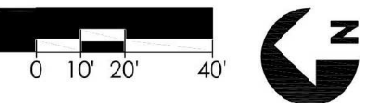

SITE PLAN #8

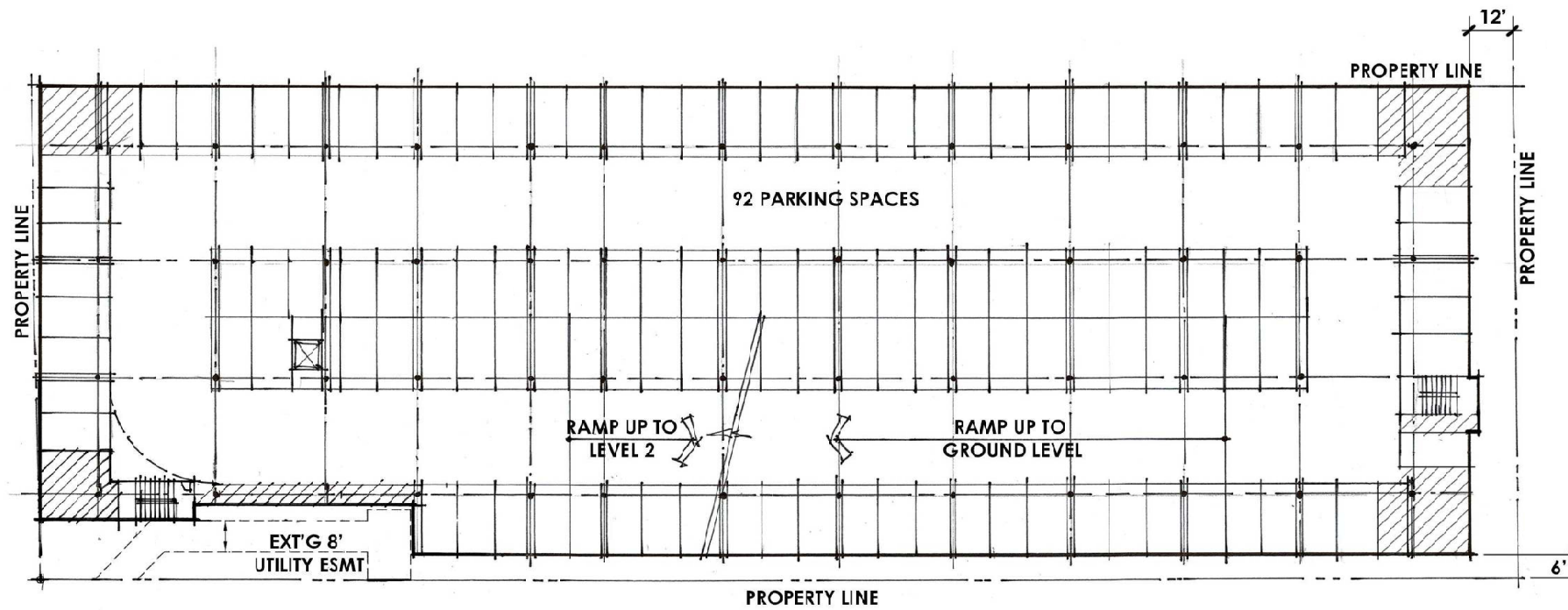

**BASEMENT LEVEL 1 PLAN**

SCALE: 1/20"=1'-0"

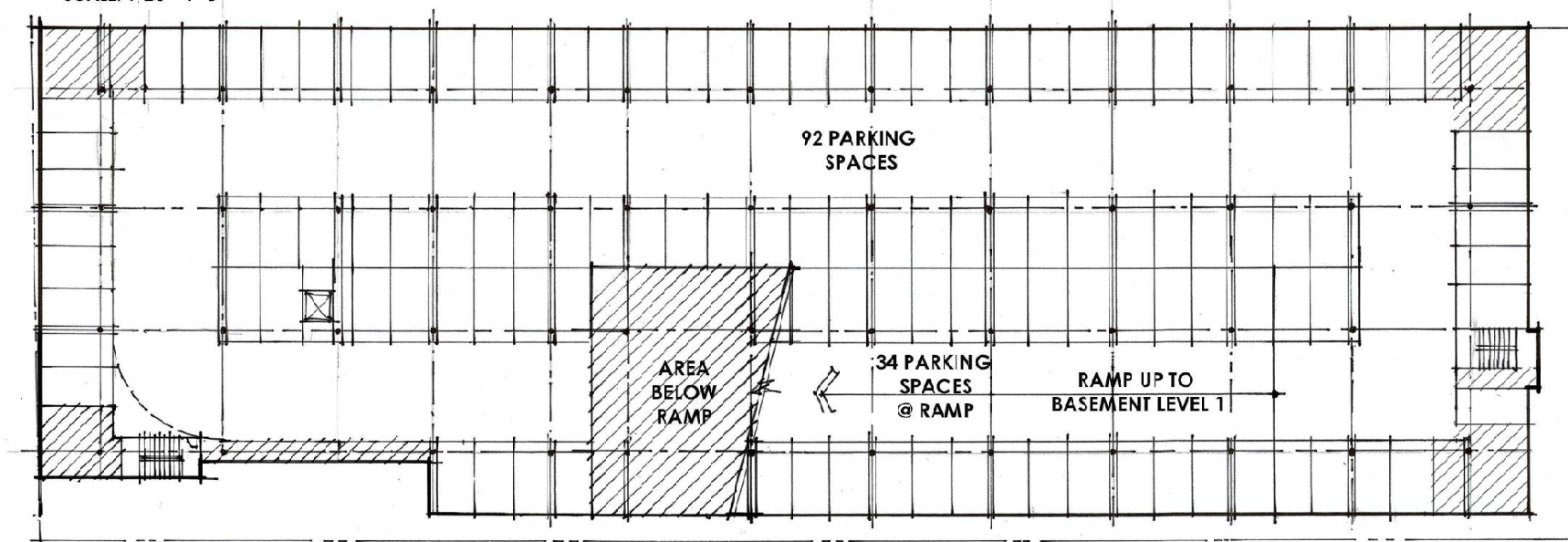

**BASEMENT LEVEL 2 PLAN**

SCALE: 1/20"=1'-0"

**CONCEPTUAL SITE PLAN**

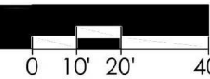

**2ND STREET AND BISHOP**

Scottsdale, Arizona

**SITE PLAN #8**

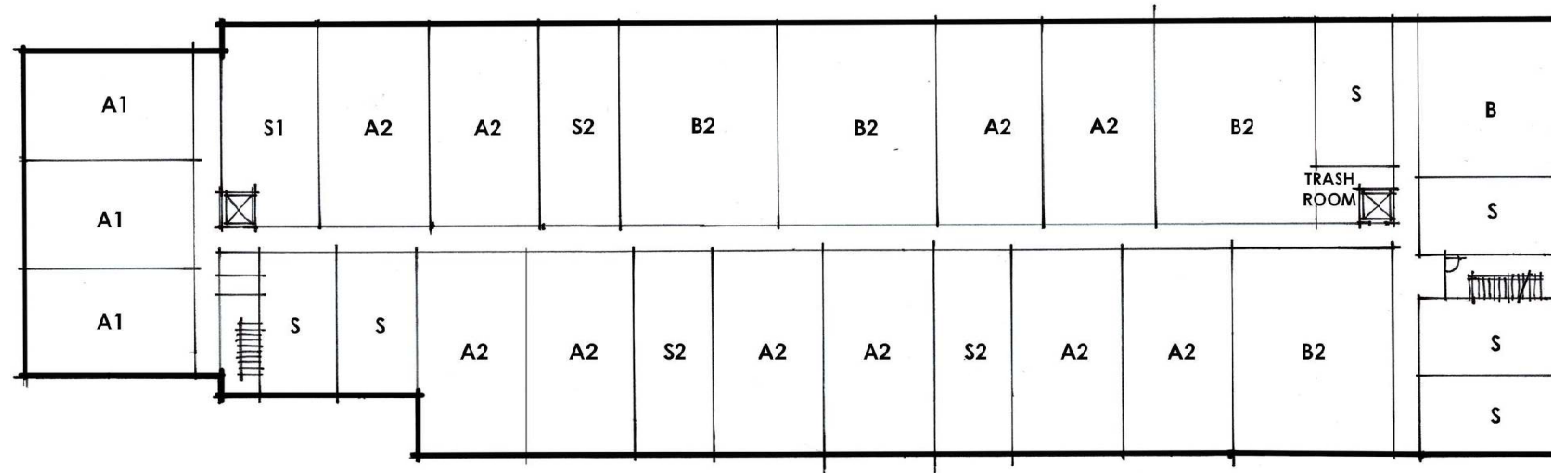

**3RD FLOOR PLAN**  
SCALE: 1/20"=1'-0"

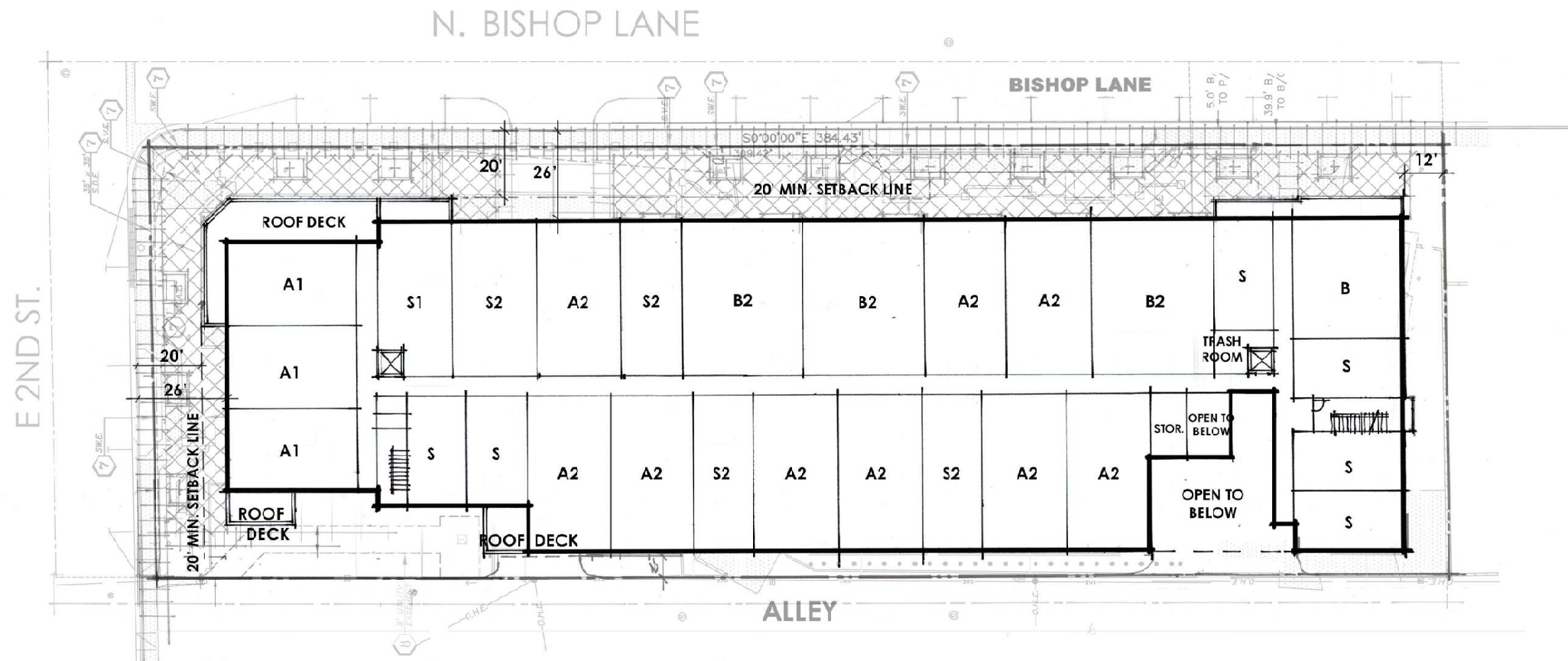

**2ND FLOOR PLAN**  
SCALE: 1/20"=1'-0"

**CONCEPTUAL SITE PLAN**

**2ND STREET AND BISHOP**

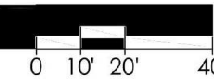

**SITE PLAN #8**

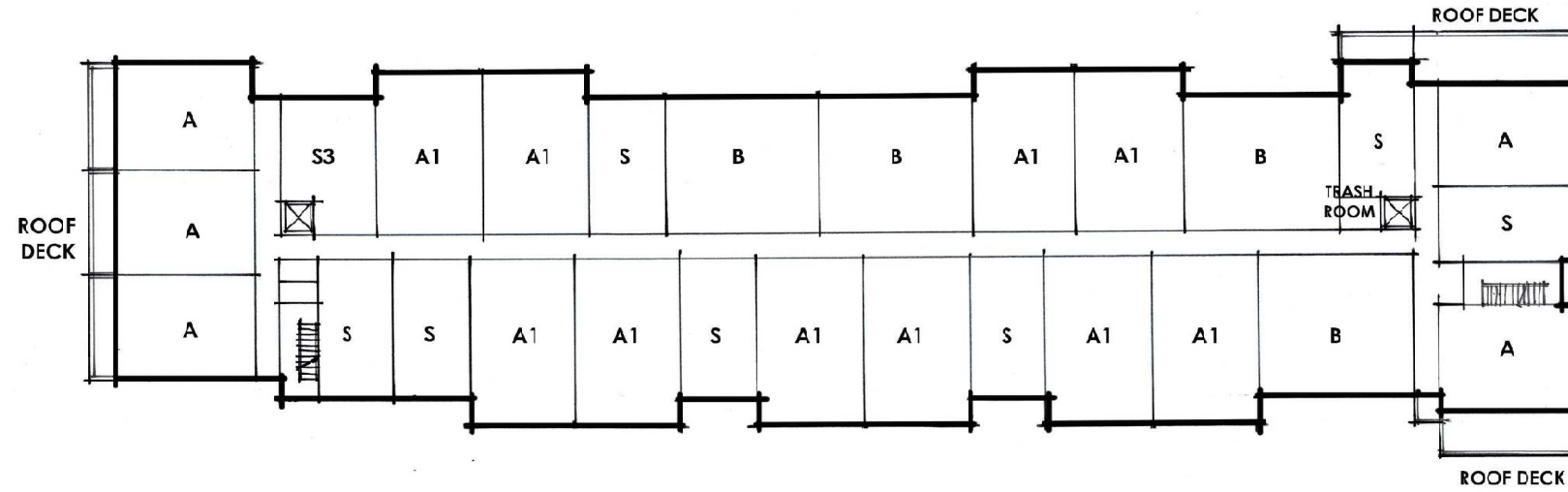

**6TH FLOOR PLAN**  
SCALE: 1/20"=1'-0"

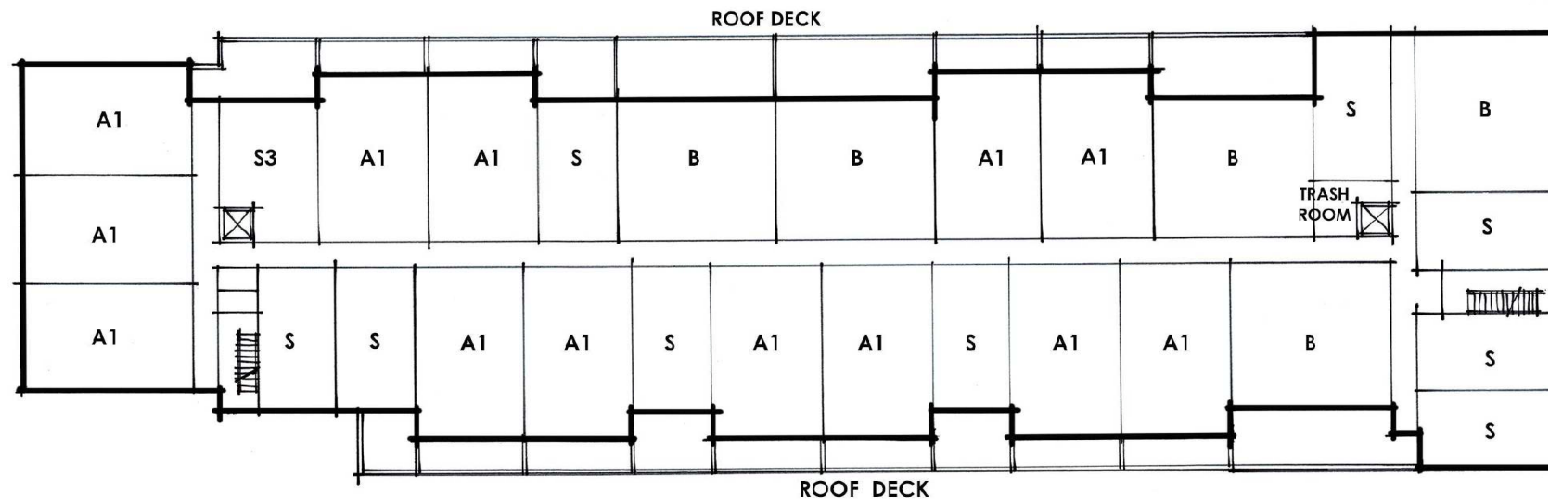

**4TH & 5TH FLOOR PLAN**  
SCALE: 1/20"=1'-0"

**CONCEPTUAL SITE PLAN**

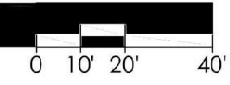

**2ND STREET AND BISHOP**

Scottsdale, Arizona

**SITE PLAN #8**

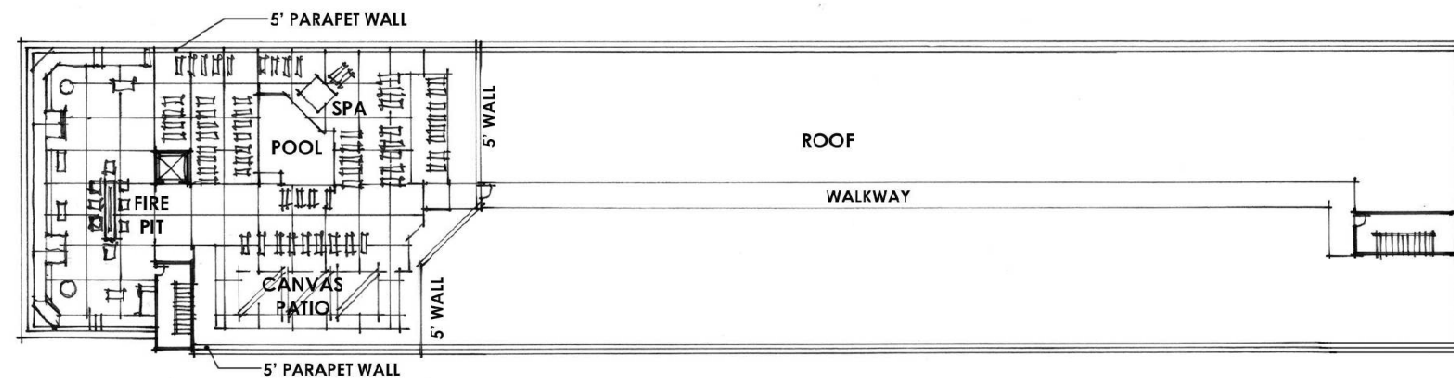

**ROOF PLAN**  
SCALE: 1/20"=1'-0"

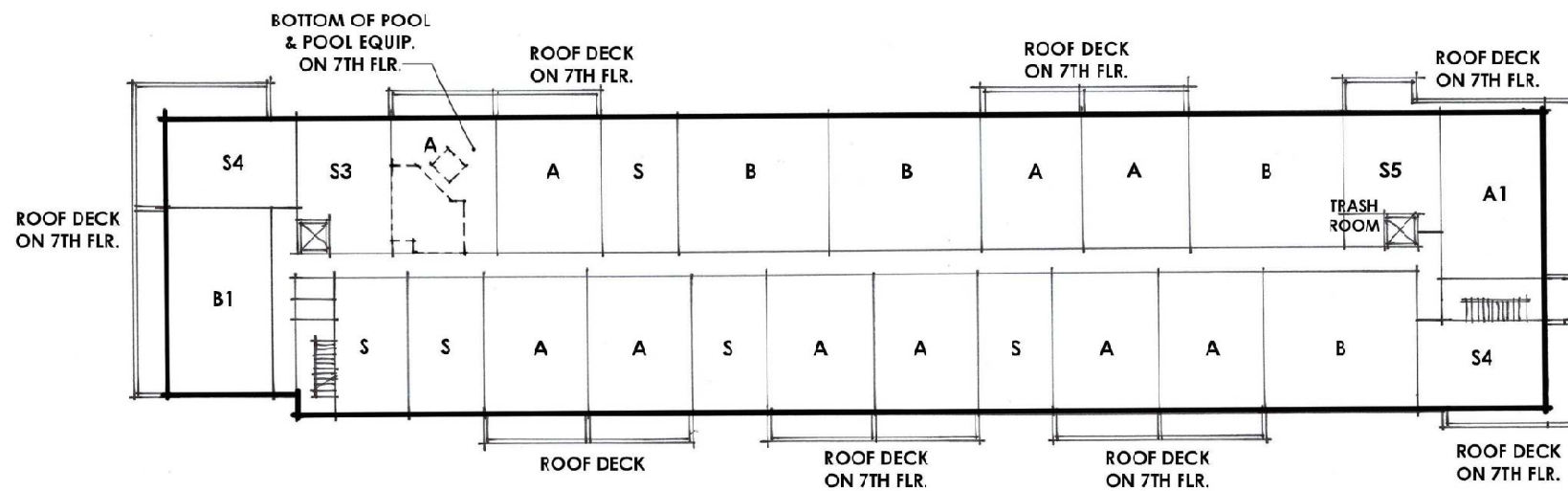

**7TH & 8TH FLOOR PLAN**  
SCALE: 1/20"=1'-0"

**CONCEPTUAL SITE PLAN**

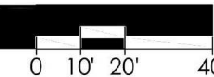

**2ND STREET AND BISHOP**

Scottsdale, Arizona

**SITE PLAN #8**

## ATTACHMENT B – CRASH DATA

REPORT #	YYMMDD	HHMM	NS ST	NS SF	EW ST	EW SF	DIR FROM	DIST FROM	AUX REF ST	DIR FROM	AUX REF ST	DOB 1	DOB 2	INJ SEV 1	INJ SEV 2	PHYSICAL COND 1	PHYSICAL COND 2	VIOL 1	VIOL 2	ACTION 1	ACTION 2	TRAVEL DIR 1	TRAVEL DIR 2	MANNER OF COLLISION	COMMENTS	DATE ENTERED	ENTERED BY	
15-02486	150130	1014	SCOTTSDALE	RD	2	ST	AT					2/13/1934	5/7/1983	3	1	0	0	6	1	1	1	EB	SB	2		42089	KAY	
15-03638	150212	1259	GOLDWATER	BL	2	ST	AT					8/7/1992	3/25/1967	3	1	0	0	5	1	1	1	EB	NB	2		42101	KAY	
15-03750	150213	1639	SCOTTSDALE	RD	2	ST	AT					6/8/1944	2/2/1973	1	1	0	0	7	1	5	4	NB	NB	6		42101	KAY	
15-04011	150217	1037	SCOTTSDALE	RD	2	ST	AT					7/6/1972	10/19/1940	2	3	0	0	99	99	1	1	SB	WB	2		42097	KAY	
15-04421	150222	1321	GOLDWATER	BL	2	ST	AT					1/25/1992	2/7/1959	1	3	0	0	20	1	1	1	WB	SB	2		42107	KAY	
15-04756	150226	1708	GOLDWATER	BL	2	ST	AT			INDIAN SCHOOL	S	11/22/1981	6/25/1983	1	1	0	0	13	1	3	5	NB	NB	6		42107	KAY	
15-06283	150317	1659	GOLDWATER	BL	2	ST	AT					8/10/1976	1/3/1983	1	1	0	0	20	1	1	1	EB	NB	5	MULTI VEH 3	42110	KAY	
15-07312	150329	1719	MARSHALL	WY	2	ST	W	205				12/13/1949		1		0	0	97	1	10	14	SB	EB	8		42111	KAY	
15-12792	150606	2213	GOLDWATER	BL	2	ST	AT					7/18/1998	12/17/1955	1	4	0	0	20	1	1	1	WB	SB	2		42185	KAY	
15-12837	150607	1226	SCOTTSDALE	RD	2	ST	AT					2/24/1985	11/20/1980	1	1	0	0	2	1	1	3	NB	NB	4		42181	KAY	
15-12836	150607	1155	SCOTTSDALE	RD	2	ST	E	101				8/2/1994	2/27/1990	1	1	0	0		1	10	1	EB	EB	8		42200	KAY	
15-13575	150617	1110	GOLDWATER	BL	2	ST	AT					2/6/1987	5/7/1962	1	1	10	0	20	1	1	1	EB	NB	2		42185	KAY	
15-18620	150825	1616	GOLDWATER	BL	2	ST	AT					9/12/1997	5/7/1996	2	2	0	0	20	1	1	1	EB	NB	2		42256	KAY	
15-18689	150826	1802	SCOTTSDALE	RD	2	ST	AT					9/14/1992	1/21/1984	1	1	0	0	97	1	1	3	NB	NB	4	MULTI VEH 3	42263	KAY	
15-19681	150908	0748	GOLDWATER	BL	2	ST	AT					2/15/1991	1/30/1981	1	1	0	0	20	1	1	1	EB	NB	2		42278	KAY	
15-20243	150915	1814	MARSHALL	WY	2	ST	AT					4/21/1989	12/6/1996	4	1	0	0	20	1	1	1	SB	EB	2		42278	KAY	
15-21434	151001	1739	GOLDWATER	BL	2	ST	AT					4/2/1981	8/25/1992	1	1	0	0	20	1	1	1	EB	NB	2		42291	KAY	
15-24849	151113	1324	GOLDWATER	BL	2	ST	AT					6/8/1958	8/17/1993	2	1	0	0	20	1	1	1	EB	SB	2		42341	KAY	
15-26521	151204	1701	GOLDWATER	BL	2	ST	AT					4/10/1976	8/20/1982	1	1	0	0	20	1	1	1	WB	SB	2		42355	KAY	
15-27180	151211	2225	SCOTTSDALE	RD	2	ST	AT					2/9/1996	12/10/1988	1	1	0	0	6	1	1	1	SB	WB	2		42368	KAY	
15-28064	151223	1529	GOLDWATER	BL	2	ST	AT					10/21/1970	7/21/1986	1	3	0	0	20	1	1	1	WB	SB	2	MULTI VEH 3	42374	KAY	
16-00607	160108	1509	GOLDWATER	BL	2	ST	AT					2/14/1924	6/9/1953	3	1	99	0		1	1	1	EB	NB	2		42389	KAY	
16-00692	160109	1707	MARSHALL	WY	2	ST	AT					7/24/1996	5/18/1977	1	1	0	4	20	1	1	1	SB	WB	2	DUI	42389	KAY	
16-02377	160130	1052	SCOTTSDALE	RD	2	ST	AT					7/27/1961	7/12/1991	1	1	0	0	2	1	1	2	NB	NB	4		42418	KAY	
16-02411	160130	1849	GOLDWATER	BL	2	ST	AT					1/16/1998	6/27/1989	1	1	0	0	20	1	1	1	WB	SB	2		42418	KAY	
16-02561	160201	1405	GOLDWATER	BL	2	ST	AT					3/3/1943	6/26/1994	1	1	0	0		1	1	1	EB	NB	2	MULTI VEH 3	42418	KAY	
16-04810	160227	1426	GOLDWATER	BL	2	ST	AT					4/25/1987	10/15/1996	1	1	0	0		1	1	1	WB	SB	2		42431	KAY	
16-06162	160314	1818	SCOTTSDALE	RD	2	ST	AT					12/23/1994	6/28/1957	1	1	0	0	6	1	1	1	SB	WB	2		42457	KAY	
16-07723	160401	1923	GOLDWATER	BL	2	ST	AT					1/24/1923	7/13/1973	1	1	0	0	20	1	4	1	WB	NB	2		42468	KAY	
16-10757	160508	2147	GOLDWATER	BL	2	ST	AT					2/24/1975	4/25/1996	1	1	0	0	20	1	1	1	WB	NB	2		42510	KAY	
16-11489	160517	2136	GOLDWATER	BL	2	ST	AT					5/29/1959	2/14/1967	2	2	0	0	20	1	1	1	WB	NB	2		42510	KAY	
16-11874	160522	1831	GOLDWATER	BL	2	ST	AT					10/10/1986	8/16/1992	1	1	0	0	20	1	1	1	WB	NB	2		42522	KAY	
16-13543	160612	1147	SCOTTSDALE	RD	2	ST	AT					10/1/1985		3		0				1		NB		1		42543	KAY	
16-16105	160716	2118	SCOTTSDALE	RD	2	ST	AT					5/13/1990	12/9/1977	1	2	4	0	6	1	1	1	SB	WB	2	DUI	42573	KAY	
16-17942	160811	1542	GOLDWATER	BL	2	ST	AT					9/4/1962	6/10/1975	1	1	0	0	20	1	1	1	WB	SB	2		42605	KAY	
16-20814	160916	1603	GOLDWATER	BL	2	ST	AT					12/12/1941	6/26/1996	1	2	0	0	20	1	1	1	EB	NB	2	1	36693	KAY	
16-20957	160918	1017	GOLDWATER	BL	2	ST	AT					8/25/1957	12/25/1970	1	3	0	0	20	1	1	1	WB	SB	2		42649	KAY	
16-21029	160919	1238	SCOTTSDALE	RD	2	ST	AT					7/17/1972	12/13/1975	1	1	0	0	6	1	1	1	NB	WB	2		42649	KAY	
16-21760	160928	1238	BISHOP	LN	2	ST	AT					10/11/1989	1/1/1962	1	1	0	0	20	1	4	1	NB	EB	3		42657	KAY	
16-22553	161008	1724	SCOTTSDALE	RD	2	ST	AT					1/1/1994	3/27/1989	1	1	99	0	6	1	1	1	SB	EB	2		42674	KAY	
16-24436	161101	1825	GOLDWATER	BL	2	ST	AT						4/15/1977	99	3	99	0	99	1	1	1	1	NB	NB	6	HIT AND RUN	42685	KAY
16-25847	161119	1501	GOLDWATER	BL	2	ST	AT					7/14/1960	4/5/1971	1	1	0	0	20	1	1	1	WB	SB	2		42706	KAY	
16-27238	161206	1013	GOLDWATER	BL	2	ST	AT					11/19/1948	5/9/1959	1	1	0	0	20	1	1	1	EB	NB	2		42727	KAY	
16-27267	161206	1503	GOLDWATER	BL	2	ST	AT					8/25/1989	1/17/1964	2	1	0	0	20	1	1	1	WB	SB	2		42727	KAY	
16-27990	161215	1253	GOLDWATER	BL	2	ST	AT					7/4/1939	4/25/1988	1	1	0	0		1	1	1	EB	NB	5		42739	KAY	
16-28065	161216	0825	GOLDWATER	BL	2	ST	AT					1/30/1952	3/12/1989	1	1	0	0	20	1	1	1	EB	NB	2		42741	KAY	
16-28485	161221	1037	GOLDWATER	BL	2	ST	AT					1/11/1971	11/14/1989	3	1	0	0	97	1	97	5	NB	EB	2	CAR/BICYCLE	42741	KAY	
17-00500	170107	1836	GOLDWATER	BL	2	ST	AT					1/12/1990	7/30/1971	1	2	0	0	5	1	4	1	EB	SB	3		1/18/2017		
17-08505	170413	1715	GOLDWATER	BL	2	ST	AT					6/19/1933	10/23/1990	1	1	0	0	2	1	13	1	WB	SB	2		4/21/2017		
17-11225	170518	2143	GOLDWATER	BL	2	ST	AT					7/17/2000	4/20/1993	3	3	0	0	5	1	1	1	WB	SB	5		6/8/2017		
17-16269	170722	1818	SCOTTSDALE	RD	2	ST	S	250				3/3/1990		1		0			1	10	14	NB	SB	4		8/7/2017		
17-16479	170725	1552	SCOTTSDALE	RD	2	ST	N	32				2/28/1976	3/7/1968	2	1	6	0	4	1	1	3	SB	SB	4		8/15/2017		
17-18755	170824	1700	SCOTTSDALE	RD	2	ST	AT					4/3/1947	10/18/1959	1	1	0	0	6	1	1	1	SB	WB	2		9/14/2017		
17-22230	171007	1559	GOLDWATER	BL	2	ST	AT					11/5/1934	10/4/1990	1	1	0	0	20	1	1	1	EB	NB	2		10/24/2017		
17-23237	171020	2023	GOLDWATER	BL	2	ST	AT					2/1/2001	8/13/1987	3	3	0	0	97	1	1	1	NB	EB	2		11/1/2017		
17-24862	171108	1542	SCOTTSDALE	RD	2	ST	N	56				1/14/1996	11/16/1955	1	1	0	0	4	1	1	3	SB	SB	4		11/22/2017		
17-27589	171213	2237	SCOTTSDALE	RD	2	ST	AT					12/30/1963		1		4		12		1		SB		97	DUI	1/29/2018		
17-28876	171261	1242	GOLDWATER	BL	2	ST	AT					3/11/1991	7/14/1979	3	1	0	0	3	20	1	1	NB	NB	2		1/30/2018		

# ATTACHMENT C – TRAFFIC COUNT DATA

**Intersection Turning Movement**  
Prepared by:



Project #: 17-1353-002

***TMC SUMMARY OF Goldwater Blvd. & 2nd St.***

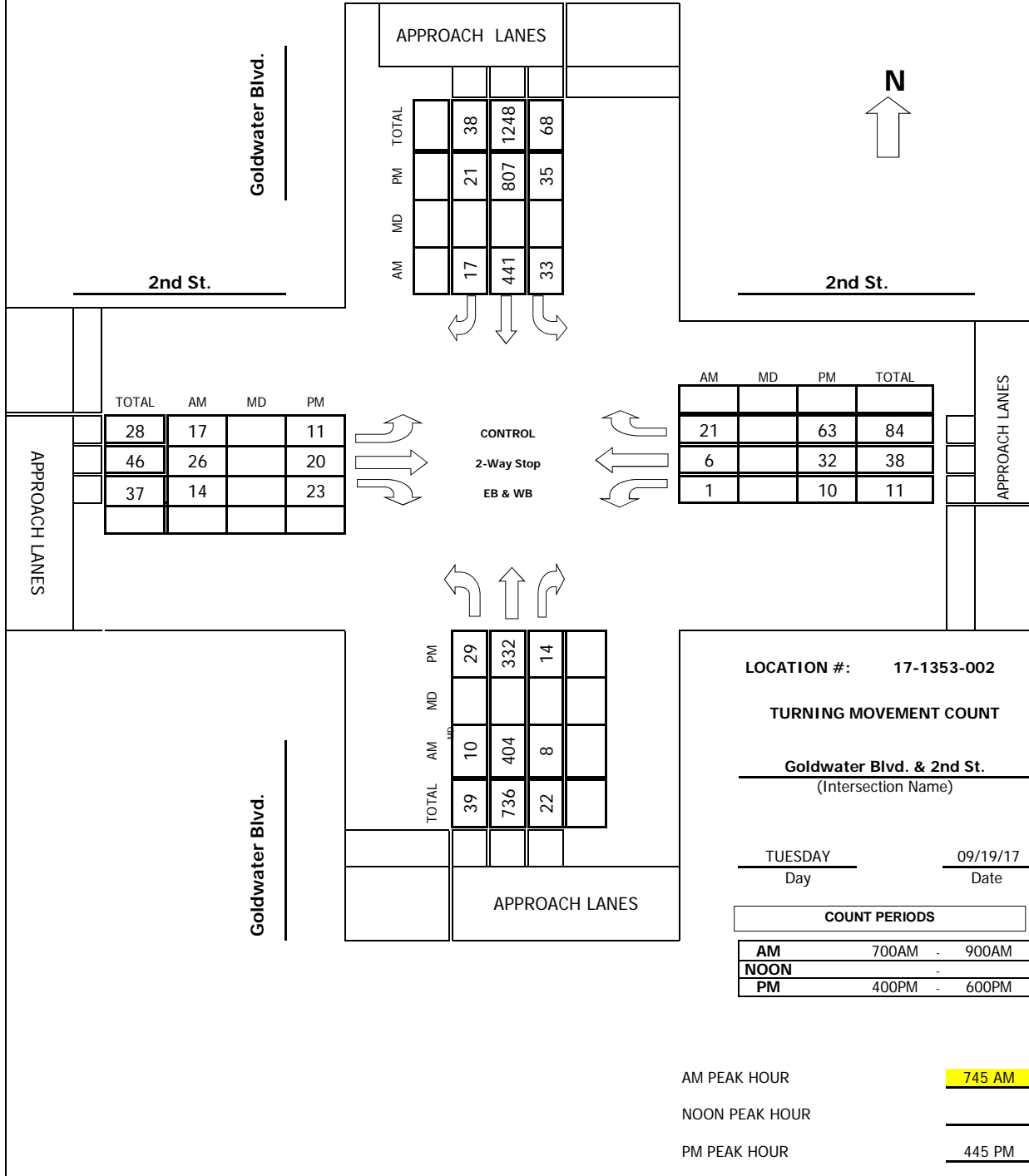

# Intersection Turning Movement

Prepared by:



**FIELD DATA SERVICES OF ARIZONA, INC.**  
520.316.6745



veracitytrafficgroup

N-S STREET: Goldwater Blvd.      DATE: 09/19/17      LOCATION: Scottsdale  
 E-W STREET: 2nd St.      DAY: TUESDAY      PROJECT#: 17-1353-002

LANES:	NORTHBOUND			SOUTHBOUND			EASTBOUND			WESTBOUND			TOTAL
	NL	NT	NR	SL	ST	SR	EL	ET	ER	WL	WT	WR	
	1	2	0	1	3	0	0	1	0	0	1	0	
6:00 AM													
6:15 AM													
6:30 AM													
6:45 AM													
7:00 AM	6	79	0	2	70	2	4	4	3	0	0	3	173
7:15 AM	2	98	2	8	72	2	3	2	5	2	2	4	202
7:30 AM	0	121	3	4	111	2	7	1	5	1	0	5	260
7:45 AM	2	113	5	12	134	1	3	7	2	0	0	4	283
8:00 AM	3	85	1	4	115	3	4	13	5	0	1	4	238
8:15 AM	1	104	1	7	106	6	5	3	4	1	1	6	245
8:30 AM	4	102	1	10	86	7	5	3	3	0	4	7	232
8:45 AM	1	97	0	3	97	3	3	7	4	0	0	4	219
9:00 AM													
9:15 AM													
9:30 AM													
9:45 AM													
10:00 AM													
10:15 AM													
10:30 AM													
10:45 AM													
11:00 AM													
11:15 AM													
11:30 AM													
11:45 AM													

TOTAL	NL	NT	NR	SL	ST	SR	EL	ET	ER	WL	WT	WR	TOTAL
Volumes	19	799	13	50	791	26	34	40	31	4	8	37	1852
Approach %	2.29	96.15	1.56	5.77	91.23	3.00	32.38	38.10	29.52	8.16	16.33	75.51	
App/Depart	831	/	870	867	/	826	105	/	103	49	/	53	

AM Peak Hr Begins at: 730 AM

**PEAK**

Volumes	10	404	8	33	441	17	17	26	14	1	6	21	998
Approach %	2.37	95.73	1.90	6.72	89.82	3.46	29.82	45.61	24.56	3.57	21.43	75.00	

**PEAK HR.**

FACTOR:	0.885	0.859	0.670	0.719	0.882
---------	-------	-------	-------	-------	-------

**CONTROL:**

2-Way Stop (EB & WB)

**COMMENT 1:**

33.491252, -111.930310





**FIELD DATA SERVICES OF ARIZONA, INC.**  
520.316.6745



veracitytrafficgroup

### Pedestrian & Bicycle Study

**N-S STREET:** Goldwater Blvd.  
**E-W STREET:** 2nd St.

**Date:** 09/19/17  
**Day:** TUESDAY

**City:** Scottsdale  
**Project #:** 17-1353-002

	PEDESTRIANS			
	N-LEG	S-LEG	E-LEG	W-LEG
7:00 AM	0	0	1	0
7:15 AM	0	0	0	3
7:30 AM	0	0	0	3
7:45 AM	0	0	1	1
8:00 AM	0	0	0	1
8:15 AM	3	0	0	0
8:30 AM	0	0	0	1
8:45 AM	0	0	0	0
<b>TOTAL</b>	<b>3</b>	<b>0</b>	<b>2</b>	<b>9</b>

	BICYCLES			
	N-LEG	S-LEG	E-LEG	W-LEG
7:00 AM	0	0	0	0
7:15 AM	0	0	0	0
7:30 AM	0	0	0	1
7:45 AM	0	0	0	0
8:00 AM	0	0	1	1
8:15 AM	0	0	0	0
8:30 AM	0	0	1	0
8:45 AM	0	0	0	0
<b>TOTAL</b>	<b>0</b>	<b>0</b>	<b>2</b>	<b>2</b>

	PEDESTRIANS			
	N-LEG	S-LEG	E-LEG	W-LEG
4:00 PM	0	0	0	0
4:15 PM	0	0	0	0
4:30 PM	0	0	0	1
4:45 PM	0	0	0	0
5:00 PM	0	0	0	0
5:15 PM	0	0	1	1
5:30 PM	0	0	0	3
5:45 PM	0	0	0	2
<b>TOTAL</b>	<b>0</b>	<b>0</b>	<b>1</b>	<b>7</b>

	BICYCLES			
	N-LEG	S-LEG	E-LEG	W-LEG
4:00 PM	0	0	0	1
4:15 PM	0	0	0	0
4:30 PM	0	0	0	0
4:45 PM	0	0	1	0
5:00 PM	0	0	0	0
5:15 PM	0	0	0	0
5:30 PM	0	0	0	0
5:45 PM	0	0	0	2
<b>TOTAL</b>	<b>0</b>	<b>0</b>	<b>1</b>	<b>3</b>

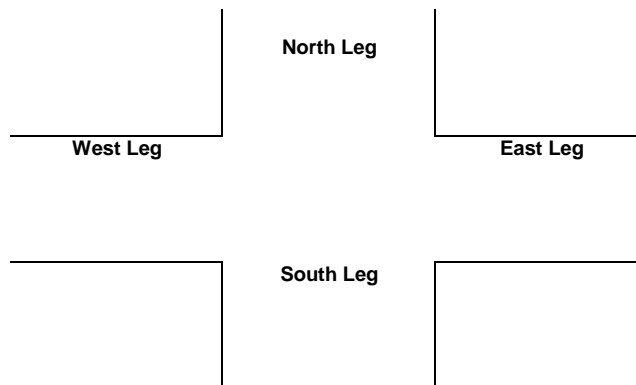

# Intersection Turning Movement

Prepared by:



Project #: 17-1353-003

## TMC SUMMARY OF Marshall Way & 2nd St.

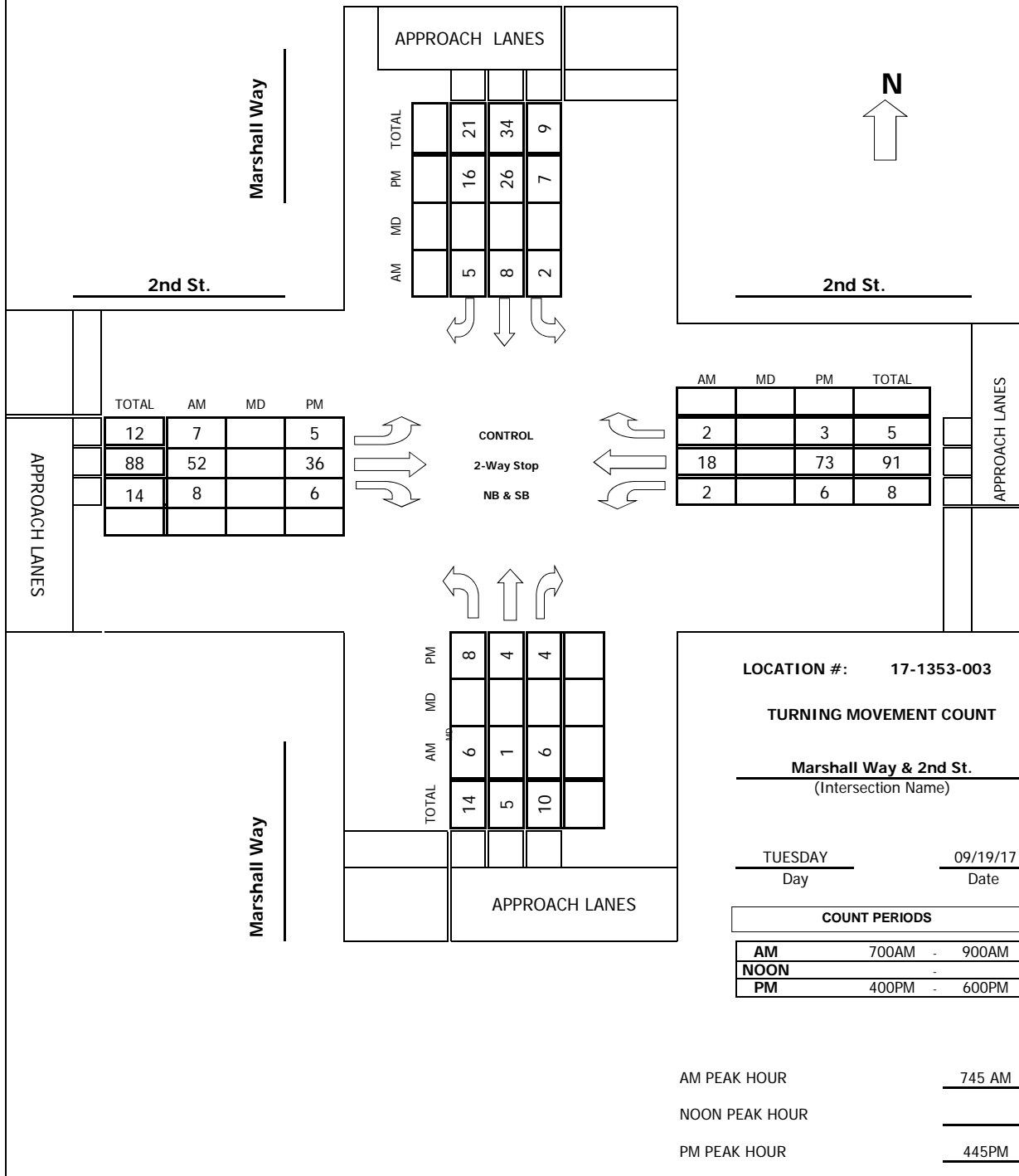

# Intersection Turning Movement

Prepared by:



**FIELD DATA SERVICES OF ARIZONA, INC.**  
520.316.6745



veracitytrafficgroup

N-S STREET: Marshall Way      DATE: 09/19/17      LOCATION: Scottsdale  
 E-W STREET: 2nd St.      DAY: TUESDAY      PROJECT#: 17-1353-003

LANES:	NORTHBOUND			SOUTHBOUND			EASTBOUND			WESTBOUND			TOTAL
	NL	NT	NR	SL	ST	SR	EL	ET	ER	WL	WT	WR	
	0	1	0	0	1	0	0	1	0	0	1	0	
6:00 AM													
6:15 AM													
6:30 AM													
6:45 AM													
7:00 AM	1	1	0	0	3	0	1	7	1	1	3	1	19
7:15 AM	0	0	0	0	0	1	1	7	1	0	7	1	18
7:30 AM	0	0	1	1	4	1	1	8	0	0	5	1	22
7:45 AM	2	1	0	0	5	1	5	19	2	0	3	2	40
8:00 AM	2	0	4	1	1	0	0	15	1	1	4	0	29
8:15 AM	2	0	2	0	2	0	0	6	3	1	4	0	20
8:30 AM	0	0	0	1	0	4	2	12	2	0	7	0	28
8:45 AM	1	0	2	1	1	2	3	6	0	2	3	0	21
9:00 AM													
9:15 AM													
9:30 AM													
9:45 AM													
10:00 AM													
10:15 AM													
10:30 AM													
10:45 AM													
11:00 AM													
11:15 AM													
11:30 AM													
11:45 AM													

TOTAL	NL	NT	NR	SL	ST	SR	EL	ET	ER	WL	WT	WR	TOTAL
Volumes	8	2	9	4	16	9	13	80	10	5	36	5	197
Approach %	42.11	10.53	47.37	13.79	55.17	31.03	12.62	77.67	9.71	10.87	78.26	10.87	
App/Depart	19	/	20	29	/	31	103	/	93	46	/	53	

AM Peak Hr Begins at: 745 AM

**PEAK**

Volumes	6	1	6	2	8	5	7	52	8	2	18	2	117
Approach %	46.15	7.69	46.15	13.33	53.33	33.33	10.45	77.61	11.94	9.09	81.82	9.09	

**PEAK HR.**

FACTOR:	0.542	0.625	0.644	0.786	0.731
---------	-------	-------	-------	-------	-------

CONTROL: 2-Way Stop (NB & SB)  
 COMMENT 1:  
 GPS: 33.491252, -111.930310

# Intersection Turning Movement



**FIELD DATA SERVICES OF ARIZONA, INC.**  
520.316.6745



veracitytrafficgroup

N-S STREET: Marshall Way      DATE: 09/19/17      LOCATION: Scottsdale  
 E-W STREET: 2nd St.      DAY: TUESDAY      PROJECT#: 17-1353-003

LANES:	NORTHBOUND			SOUTHBOUND			EASTBOUND			WESTBOUND			TOTAL
	NL	NT	NR	SL	ST	SR	EL	ET	ER	WL	WT	WR	
	0	1	0	0	1	0	0	1	0	0	1	0	
1:00 PM													
1:15 PM													
1:30 PM													
1:45 PM													
2:00 PM													
2:15 PM													
2:30 PM													
2:45 PM													
3:00 PM													
3:15 PM													
3:30 PM													
3:45 PM													
4:00 PM	2	1	0	2	2	3	0	10	0	2	13	1	36
4:15 PM	1	0	1	0	4	0	0	6	2	0	10	0	24
4:30 PM	1	2	1	1	8	4	0	12	0	1	17	2	49
4:45 PM	3	1	1	4	6	9	3	12	1	0	11	1	52
5:00 PM	3	1	0	1	12	5	0	7	2	1	20	0	52
5:15 PM	1	0	2	1	4	2	0	9	2	5	29	1	56
5:30 PM	1	2	1	1	4	0	2	8	1	0	13	1	34
5:45 PM	1	0	3	0	1	5	0	11	2	0	6	0	29
6:00 PM													
6:15 PM													
6:30 PM													
6:45 PM													

TOTAL	NL	NT	NR	SL	ST	SR	EL	ET	ER	WL	WT	WR	TOTAL
Volumes	13	7	9	10	41	28	5	75	10	9	119	6	332
Approach %	44.83	24.14	31.03	12.66	51.90	35.44	5.56	83.33	11.11	6.72	88.81	4.48	
App/Depart	29	/	18	79	/	60	90	/	94	134	/	160	

PM Peak Hr Begins at: 430 PM

**PEAK**

Volumes	8	4	4	7	26	16	5	36	6	6	73	3	194
Approach %	50.00	25.00	25.00	14.29	53.06	32.65	10.64	76.60	12.77	7.32	89.02	3.66	

**PEAK HR.**

FACTOR:	0.800	0.750	0.750	0.629	0.866
---------	-------	-------	-------	-------	-------

CONTROL: 2-Way Stop (NB & SB)  
 COMMENT 1: 0  
 GPS: 33.491252, -111.930310



**FIELD DATA SERVICES OF ARIZONA, INC.**  
520.316.6745



veracitytrafficgroup

### Pedestrian & Bicycle Study

**N-S STREET:** Marshall Way  
**E-W STREET:** 2nd St.

**Date:** 09/19/17  
**Day:** TUESDAY

**City:** Scottsdale  
**Project #:** 17-1353-003

	PEDESTRIANS			
	N-LEG	S-LEG	E-LEG	W-LEG
7:00 AM	1	0	0	0
7:15 AM	0	0	0	0
7:30 AM	0	0	0	0
7:45 AM	0	0	0	0
8:00 AM	1	0	0	0
8:15 AM	0	2	0	0
8:30 AM	0	0	0	0
8:45 AM	0	0	0	0
<b>TOTAL</b>	<b>2</b>	<b>2</b>	<b>0</b>	<b>0</b>

	BICYCLES			
	N-LEG	S-LEG	E-LEG	W-LEG
7:00 AM	0	0	0	0
7:15 AM	0	0	0	0
7:30 AM	0	0	1	0
7:45 AM	0	0	0	0
8:00 AM	0	0	0	0
8:15 AM	0	0	0	0
8:30 AM	0	0	0	0
8:45 AM	0	0	0	0
<b>TOTAL</b>	<b>0</b>	<b>0</b>	<b>1</b>	<b>0</b>

	PEDESTRIANS			
	N-LEG	S-LEG	E-LEG	W-LEG
4:00 PM	0	1	0	0
4:15 PM	0	0	0	0
4:30 PM	0	0	0	0
4:45 PM	0	0	0	0
5:00 PM	0	0	0	0
5:15 PM	0	0	0	0
5:30 PM	0	0	0	0
5:45 PM	1	0	0	0
<b>TOTAL</b>	<b>1</b>	<b>1</b>	<b>0</b>	<b>0</b>

	BICYCLES			
	N-LEG	S-LEG	E-LEG	W-LEG
4:00 PM	0	0	0	0
4:15 PM	0	0	0	0
4:30 PM	0	0	0	0
4:45 PM	0	0	0	0
5:00 PM	0	0	0	0
5:15 PM	0	0	0	0
5:30 PM	0	0	0	0
5:45 PM	0	0	0	0
<b>TOTAL</b>	<b>0</b>	<b>0</b>	<b>0</b>	<b>0</b>

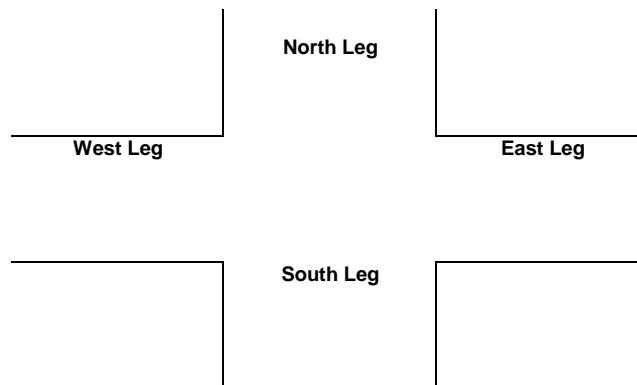

# Intersection Turning Movement

Prepared by:



Project #: 17-1353-008

## TMC SUMMARY OF Scottsdale Rd. & 2nd St.

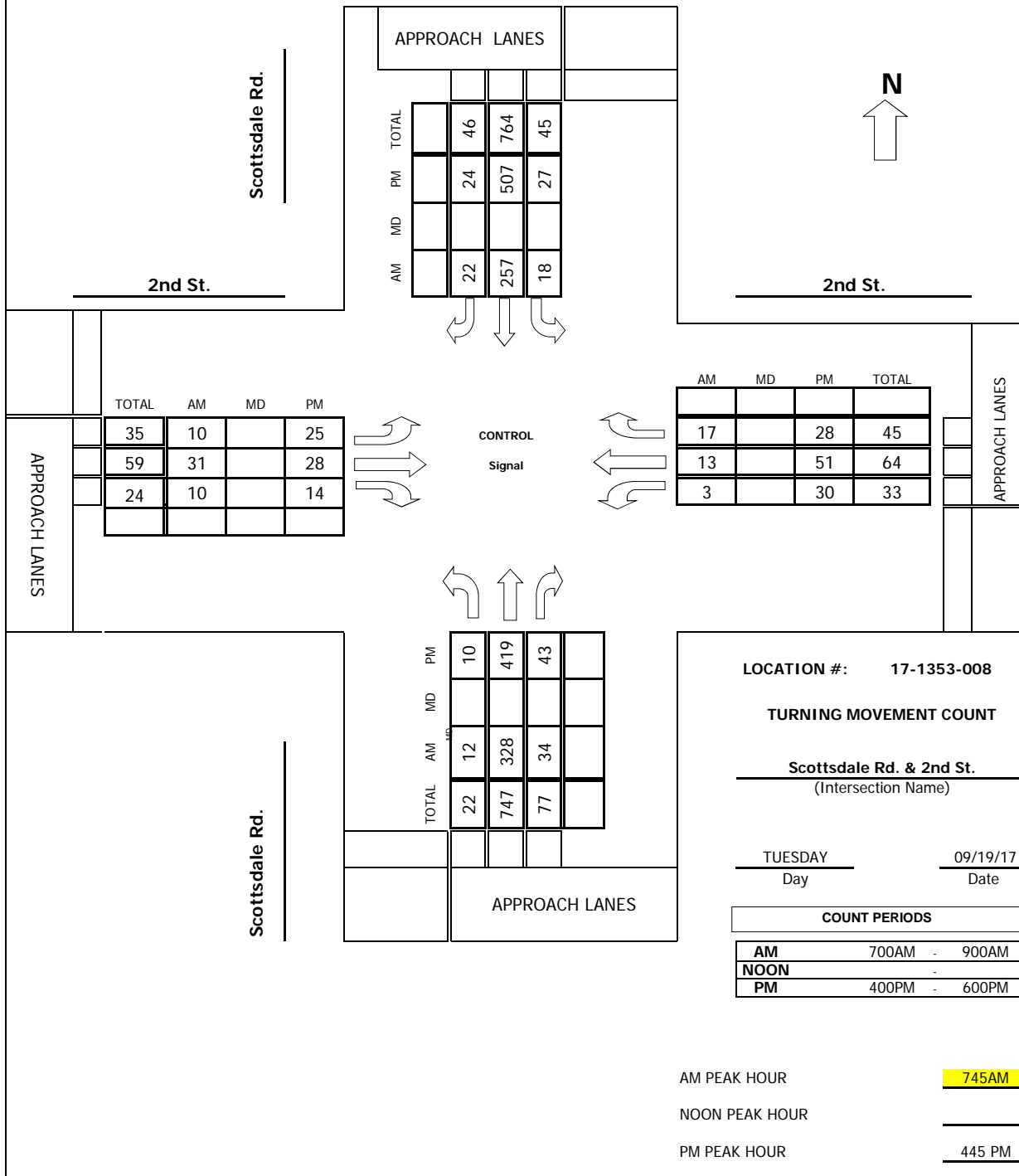

# Intersection Turning Movement

Prepared by:



**FIELD DATA SERVICES OF ARIZONA, INC.**  
520.316.6745



veracitytrafficgroup

N-S STREET: Scottsdale Rd.      DATE: 09/19/17      LOCATION: Scottsdale  
 E-W STREET: 2nd St.      DAY: TUESDAY      PROJECT#: 17-1353-008

LANES:	NORTHBOUND			SOUTHBOUND			EASTBOUND			WESTBOUND			TOTAL
	NL	NT	NR	SL	ST	SR	EL	ET	ER	WL	WT	WR	
	1	2	0	1	2	0	1	1	0	0	1	0	
6:00 AM													
6:15 AM													
6:30 AM													
6:45 AM													
7:00 AM	0	52	4	2	38	1	2	5	2	2	2	3	113
7:15 AM	1	63	4	5	56	2	0	6	2	1	6	1	147
7:30 AM	3	91	7	4	49	2	0	4	5	2	2	4	173
7:45 AM	3	78	9	4	68	3	1	11	4	1	3	4	189
8:00 AM	1	64	7	7	74	4	6	6	1	1	3	3	177
8:15 AM	2	100	10	5	50	7	2	4	3	1	2	7	193
8:30 AM	6	86	8	2	65	8	1	10	2	0	5	3	196
8:45 AM	4	86	11	5	65	3	2	4	4	5	5	4	198
9:00 AM													
9:15 AM													
9:30 AM													
9:45 AM													
10:00 AM													
10:15 AM													
10:30 AM													
10:45 AM													
11:00 AM													
11:15 AM													
11:30 AM													
11:45 AM													

TOTAL	NL	NT	NR	SL	ST	SR	EL	ET	ER	WL	WT	WR	TOTAL
Volumes	20	620	60	34	465	30	14	50	23	13	28	29	1386
Approach %	2.86	88.57	8.57	6.43	87.90	5.67	16.09	57.47	26.44	18.57	40.00	41.43	
App/Depart	700	/	663	529	/	501	87	/	144	70	/	78	

AM Peak Hr Begins at: 800 AM

PEAK

Volumes	12	328	34	18	257	22	10	31	10	3	13	17	755
Approach %	3.21	87.70	9.09	6.06	86.53	7.41	19.61	60.78	19.61	9.09	39.39	51.52	

PEAK HR. FACTOR:

	0.859	0.868	0.865	0.696	0.963
--	-------	-------	-------	-------	-------

CONTROL: Signal  
 COMMENT 1:  
 GPS: 33.491322, -111.926124





### Pedestrian & Bicycle Study

**N-S STREET:** Scottsdale Rd.  
**E-W STREET:** 2nd St.

**Date:** 09/19/17  
**Day:** TUESDAY

**City:** Scottsdale  
**Project #:** 17-1353-008

	PEDESTRIANS			
	N-LEG	S-LEG	E-LEG	W-LEG
7:00 AM	1	1	1	2
7:15 AM	0	0	2	1
7:30 AM	1	0	1	0
7:45 AM	0	0	1	0
8:00 AM	2	0	1	1
8:15 AM	2	0	0	2
8:30 AM	2	0	2	2
8:45 AM	0	0	3	0
<b>TOTAL</b>	<b>8</b>	<b>1</b>	<b>11</b>	<b>8</b>

	BICYCLES			
	N-LEG	S-LEG	E-LEG	W-LEG
7:00 AM	0	0	0	0
7:15 AM	0	0	0	0
7:30 AM	0	1	0	0
7:45 AM	0	0	0	0
8:00 AM	0	0	0	0
8:15 AM	0	0	0	0
8:30 AM	0	0	0	0
8:45 AM	0	0	2	0
<b>TOTAL</b>	<b>0</b>	<b>1</b>	<b>2</b>	<b>0</b>

	PEDESTRIANS			
	N-LEG	S-LEG	E-LEG	W-LEG
4:00 PM	1	3	3	3
4:15 PM	1	0	0	2
4:30 PM	0	0	0	0
4:45 PM	0	2	2	1
5:00 PM	0	0	6	1
5:15 PM	1	1	4	2
5:30 PM	3	1	0	5
5:45 PM	3	1	5	0
<b>TOTAL</b>	<b>9</b>	<b>8</b>	<b>20</b>	<b>14</b>

	BICYCLES			
	N-LEG	S-LEG	E-LEG	W-LEG
4:00 PM	0	0	0	0
4:15 PM	0	0	1	0
4:30 PM	0	0	0	0
4:45 PM	0	0	0	0
5:00 PM	0	0	0	0
5:15 PM	0	0	1	0
5:30 PM	0	0	2	0
5:45 PM	0	1	0	0
<b>TOTAL</b>	<b>0</b>	<b>1</b>	<b>4</b>	<b>0</b>

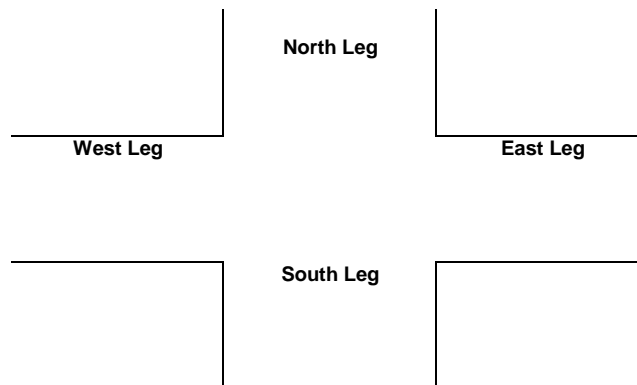

**Intersection Turning Movement**  
Prepared by:



Project #: 18-1152-004

***TMC SUMMARY OF 70th St. & Goldwater Blvd.***

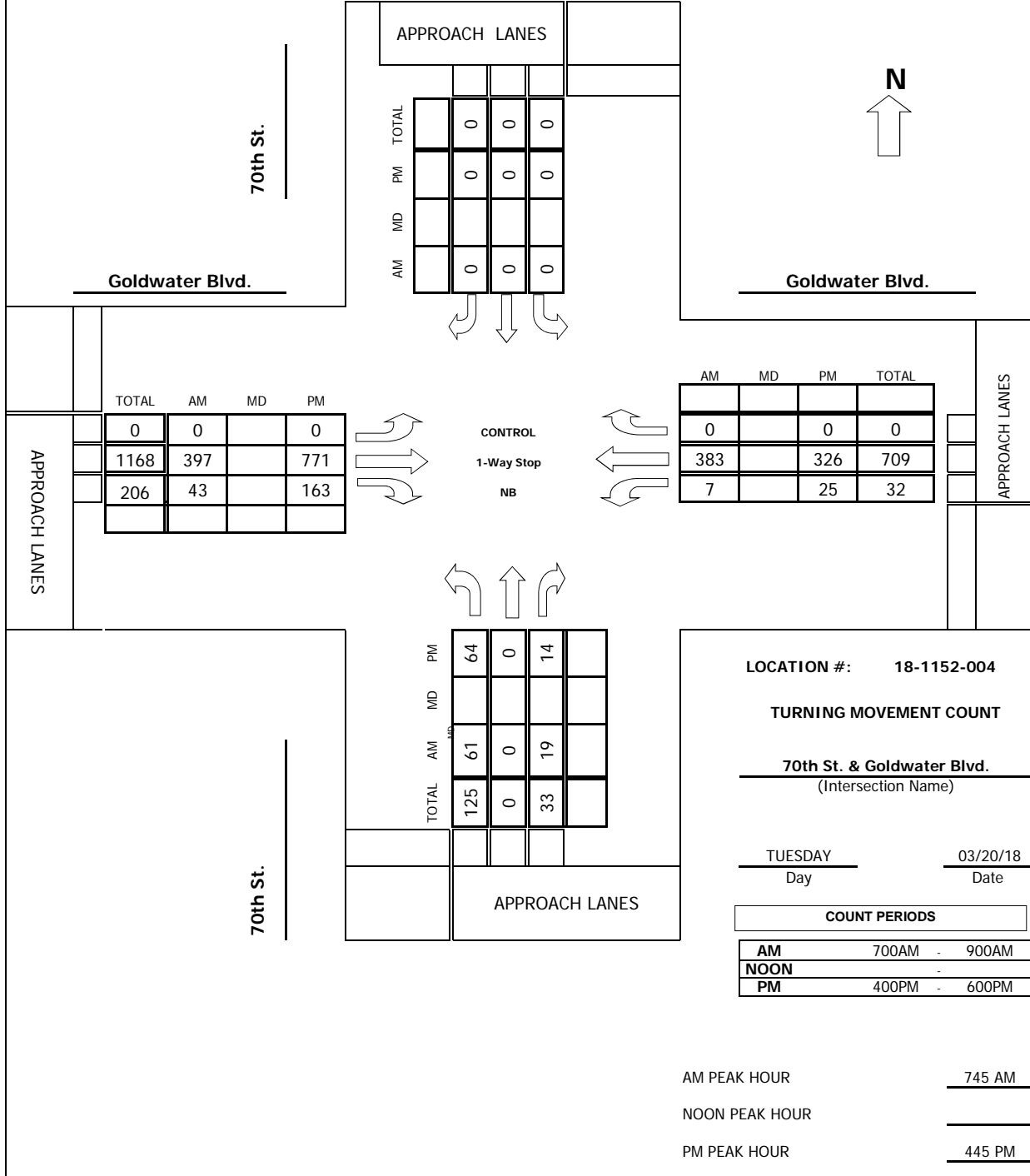

# Intersection Turning Movement

Prepared by:



**FIELD DATA SERVICES OF ARIZONA, INC.**  
520.316.6745



N-S STREET: 70th St.      DATE: 03/20/18      LOCATION: Scottsdale  
 E-W STREET: Goldwater Blvd.      DAY: TUESDAY      PROJECT#: 18-1152-004

LANES:	NORTHBOUND			SOUTHBOUND			EASTBOUND			WESTBOUND			TOTAL
	NL	NT	NR	SL	ST	SR	EL	ET	ER	WL	WT	WR	
	1	0	1	0	0	0	0	3	0	1	2	0	
6:00 AM													
6:15 AM													
6:30 AM													
6:45 AM													
7:00 AM	16	0	4	0	0	0	0	69	9	1	71	0	170
7:15 AM	23	0	3	0	0	0	0	90	5	4	73	0	198
7:30 AM	22	0	3	0	0	0	0	101	15	3	105	0	249
7:45 AM	15	0	3	0	0	0	0	115	14	2	111	0	260
8:00 AM	13	0	4	0	0	0	0	100	6	2	100	0	225
8:15 AM	18	0	6	0	0	0	0	92	12	1	82	0	211
8:30 AM	15	0	6	0	0	0	0	90	11	2	90	0	214
8:45 AM	21	0	5	0	0	0	0	95	10	4	87	0	222
9:00 AM													
9:15 AM													
9:30 AM													
9:45 AM													
10:00 AM													
10:15 AM													
10:30 AM													
10:45 AM													
11:00 AM													
11:15 AM													
11:30 AM													
11:45 AM													

TOTAL	NL	NT	NR	SL	ST	SR	EL	ET	ER	WL	WT	WR	TOTAL
Volumes	143	0	34	0	0	0	0	752	82	19	719	0	1749
Approach %	80.79	0.00	19.21	####	####	####	0.00	90.17	9.83	2.57	97.43	0.00	
App/Depart	177	/	0	0	/	101	834	/	786	738	/	862	

AM Peak Hr Begins at: 745 AM

**PEAK**

Volumes	61	0	19	0	0	0	0	397	43	7	383	0	910
Approach %	76.25	0.00	23.75	####	####	####	0.00	90.23	9.77	1.79	98.21	0.00	

**PEAK HR.**

FACTOR:	0.833	0.000	0.853	0.863	0.875
---------	-------	-------	-------	-------	-------

CONTROL: 1-Way Stop (NB)  
 COMMENT 1:  
 GPS: 33.490203, -111.929864

# Intersection Turning Movement



**FIELD DATA SERVICES OF ARIZONA, INC.**  
520.316.6745



veracitytrafficgroup

N-S STREET: 70th St. DATE: 03/20/18 LOCATION: Scottsdale  
 E-W STREET: Goldwater Blvd. DAY: TUESDAY PROJECT#: 18-1152-004

LANES:	NORTHBOUND			SOUTHBOUND			EASTBOUND			WESTBOUND			TOTAL
	NL	NT	NR	SL	ST	SR	EL	ET	ER	WL	WT	WR	
	1	0	1	0	0	0	0	3	0	1	2	0	
1:00 PM													
1:15 PM													
1:30 PM													
1:45 PM													
2:00 PM													
2:15 PM													
2:30 PM													
2:45 PM													
3:00 PM													
3:15 PM													
3:30 PM													
3:45 PM													
4:00 PM	24	0	4	0	0	0	0	187	32	6	95	0	348
4:15 PM	18	0	3	0	0	0	0	128	36	6	105	0	296
4:30 PM	17	0	5	0	0	0	0	182	34	6	89	0	333
4:45 PM	17	0	7	0	0	0	0	165	34	6	89	0	318
5:00 PM	17	0	2	0	0	0	0	213	43	5	82	0	362
5:15 PM	17	0	3	0	0	0	0	199	40	9	96	0	364
5:30 PM	13	0	2	0	0	0	0	194	46	5	59	0	319
5:45 PM	13	0	2	0	0	0	0	135	36	6	74	0	266
6:00 PM													
6:15 PM													
6:30 PM													
6:45 PM													

TOTAL	NL	NT	NR	SL	ST	SR	EL	ET	ER	WL	WT	WR	TOTAL
Volumes	136	0	28	0	0	0	0	1403	301	49	689	0	2606
Approach %	82.93	0.00	17.07	####	####	####	0.00	82.34	17.66	6.64	93.36	0.00	
App/Depart	164	/	0	0	/	350	1704	/	1431	738	/	825	

PM Peak Hr Begins at: 445 PM

PEAK

Volumes	64	0	14	0	0	0	0	771	163	25	326	0	1363
Approach %	82.05	0.00	17.95	####	####	####	0.00	82.55	17.45	7.12	92.88	0.00	

PEAK HR. FACTOR:

	0.813	0.000	0.912	0.836	0.936
--	-------	-------	-------	-------	-------

CONTROL: 1-Way Stop (NB)  
 COMMENT 1: 0  
 GPS: 33.490203, -111.929864



**FIELD DATA SERVICES OF ARIZONA, INC.**  
520.316.6745



veracitytrafficgroup

### Pedestrian & Bicycle Study

**N-S STREET:** 70th St.  
**E-W STREET:** Goldwater Blvd.

**Date:** 03/20/18  
**Day:** TUESDAY

**City:** Scottsdale  
**Project #:** 18-1152-004

	PEDESTRIANS			
	N-LEG	S-LEG	E-LEG	W-LEG
7:00 AM	0	0	0	0
7:15 AM	0	0	0	0
7:30 AM	0	3	0	0
7:45 AM	0	1	0	0
8:00 AM	0	0	0	0
8:15 AM	0	6	0	2
8:30 AM	0	1	0	0
8:45 AM	0	0	0	0
<b>TOTAL</b>	<b>0</b>	<b>11</b>	<b>0</b>	<b>2</b>

	BICYCLES			
	N-LEG	S-LEG	E-LEG	W-LEG
7:00 AM	0	0	0	0
7:15 AM	0	0	0	0
7:30 AM	0	1	0	0
7:45 AM	0	5	0	0
8:00 AM	0	0	0	0
8:15 AM	0	0	0	0
8:30 AM	0	0	0	0
8:45 AM	0	0	0	0
<b>TOTAL</b>	<b>0</b>	<b>6</b>	<b>0</b>	<b>0</b>

	PEDESTRIANS			
	N-LEG	S-LEG	E-LEG	W-LEG
4:00 PM	0	4	0	1
4:15 PM	0	5	2	1
4:30 PM	0	0	0	0
4:45 PM	0	6	0	0
5:00 PM	0	3	0	0
5:15 PM	0	0	0	2
5:30 PM	0	2	0	0
5:45 PM	0	0	3	0
<b>TOTAL</b>	<b>0</b>	<b>20</b>	<b>5</b>	<b>4</b>

	BICYCLES			
	N-LEG	S-LEG	E-LEG	W-LEG
4:00 PM	0	1	0	0
4:15 PM	0	1	0	0
4:30 PM	0	0	0	0
4:45 PM	0	1	0	0
5:00 PM	0	1	0	0
5:15 PM	0	0	0	0
5:30 PM	0	2	0	0
5:45 PM	0	0	0	0
<b>TOTAL</b>	<b>0</b>	<b>6</b>	<b>0</b>	<b>0</b>

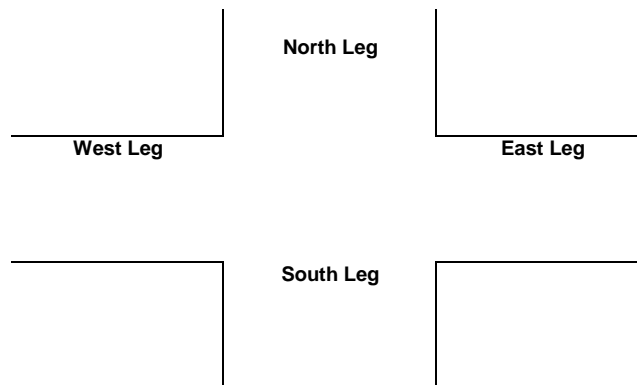

# Intersection Turning Movement

Prepared by:

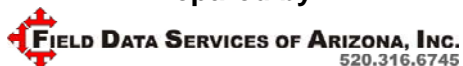

Project #: 18-1152-005

## TMC SUMMARY OF Marshall Way & Goldwater Blvd.

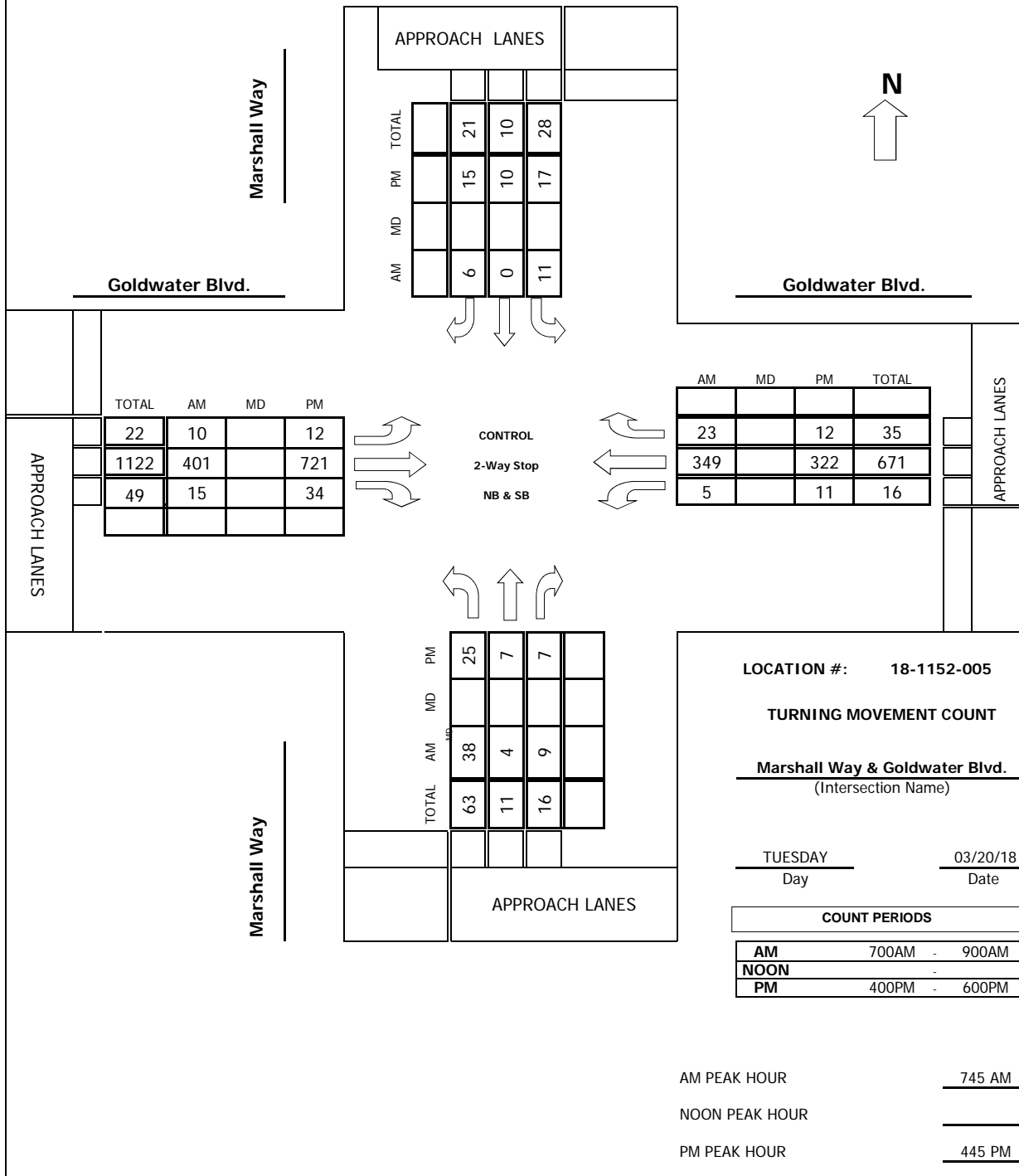

# Intersection Turning Movement

Prepared by:



**FIELD DATA SERVICES OF ARIZONA, INC.**  
520.316.6745



N-S STREET: Marshall Way      DATE: 03/20/18      LOCATION: Scottsdale  
 E-W STREET: Goldwater Blvd.      DAY: TUESDAY      PROJECT#: 18-1152-005

LANES:	NORTHBOUND			SOUTHBOUND			EASTBOUND			WESTBOUND			TOTAL
	NL	NT	NR	SL	ST	SR	EL	ET	ER	WL	WT	WR	
	0	1	0	0	1	1	1	3	0	1	2	0	
6:00 AM													
6:15 AM													
6:30 AM													
6:45 AM													
7:00 AM	5	0	3	0	0	1	0	70	3	0	54	1	137
7:15 AM	8	2	1	2	1	2	0	85	3	1	72	2	179
7:30 AM	8	1	6	0	0	2	0	87	3	1	86	0	194
7:45 AM	8	0	2	3	0	1	2	124	0	2	109	3	254
8:00 AM	12	0	3	1	0	1	1	98	3	0	80	2	201
8:15 AM	12	1	3	3	0	2	3	89	6	2	88	8	217
8:30 AM	6	3	1	4	0	2	4	90	6	1	72	10	199
8:45 AM	13	4	2	3	0	0	2	94	8	1	77	7	211
9:00 AM													
9:15 AM													
9:30 AM													
9:45 AM													
10:00 AM													
10:15 AM													
10:30 AM													
10:45 AM													
11:00 AM													
11:15 AM													
11:30 AM													
11:45 AM													

TOTAL	NL	NT	NR	SL	ST	SR	EL	ET	ER	WL	WT	WR	TOTAL
Volumes	72	11	21	16	1	11	12	737	32	8	638	33	1592
Approach %	69.23	10.58	20.19	57.14	3.57	39.29	1.54	94.37	4.10	1.18	93.96	4.86	
App/Depart	104	/	56	28	/	41	781	/	774	679	/	721	

AM Peak Hr Begins at: 745 AM

**PEAK**

Volumes	38	4	9	11	0	6	10	401	15	5	349	23	871
Approach %	74.51	7.84	17.65	64.71	0.00	35.29	2.35	94.13	3.52	1.33	92.57	6.10	

**PEAK HR.**

FACTOR:	0.797	0.708	0.845	0.827	0.857
---------	-------	-------	-------	-------	-------

CONTROL: 1-Way Stop (NB & SB)  
 COMMENT 1:  
 GPS: 33.489687, -111.928295





### Pedestrian & Bicycle Study

**N-S STREET:** Marshall Way  
**E-W STREET:** Goldwater Blvd.

**Date:** 03/20/18  
**Day:** TUESDAY

**City:** Scottsdale  
**Project #:** 18-1152-005

	PEDESTRIANS			
	N-LEG	S-LEG	E-LEG	W-LEG
7:00 AM	0	0	1	1
7:15 AM	0	0	0	0
7:30 AM	0	0	1	0
7:45 AM	0	1	1	0
8:00 AM	0	1	0	1
8:15 AM	0	0	0	1
8:30 AM	0	1	1	3
8:45 AM	2	0	1	2
<b>TOTAL</b>	<b>2</b>	<b>3</b>	<b>5</b>	<b>8</b>

	BICYCLES			
	N-LEG	S-LEG	E-LEG	W-LEG
7:00 AM	0	0	0	0
7:15 AM	0	0	2	0
7:30 AM	0	0	0	0
7:45 AM	0	0	0	0
8:00 AM	0	1	0	0
8:15 AM	0	1	0	0
8:30 AM	0	0	0	0
8:45 AM	2	0	1	0
<b>TOTAL</b>	<b>2</b>	<b>2</b>	<b>3</b>	<b>0</b>

	PEDESTRIANS			
	N-LEG	S-LEG	E-LEG	W-LEG
4:00 PM	4	4	0	2
4:15 PM	7	5	2	2
4:30 PM	2	5	0	5
4:45 PM	0	2	0	0
5:00 PM	0	5	1	2
5:15 PM	1	0	0	1
5:30 PM	0	2	3	1
5:45 PM	0	5	2	2
<b>TOTAL</b>	<b>14</b>	<b>28</b>	<b>8</b>	<b>15</b>

	BICYCLES			
	N-LEG	S-LEG	E-LEG	W-LEG
4:00 PM	0	0	0	0
4:15 PM	0	0	0	0
4:30 PM	2	0	0	0
4:45 PM	1	0	1	0
5:00 PM	0	1	0	0
5:15 PM	0	0	0	0
5:30 PM	1	0	0	0
5:45 PM	0	0	0	1
<b>TOTAL</b>	<b>4</b>	<b>1</b>	<b>1</b>	<b>1</b>

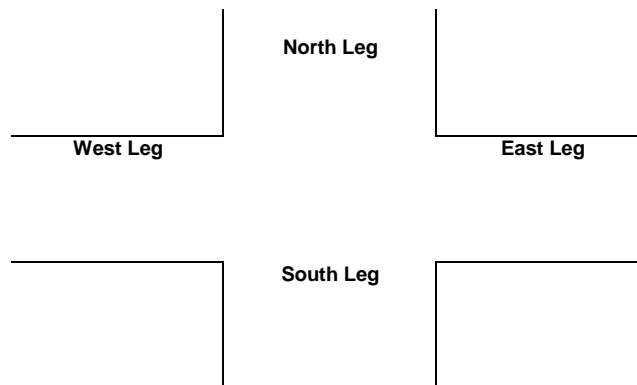



# Intersection Turning Movement

Prepared by:



**FIELD DATA SERVICES OF ARIZONA, INC.**  
520.316.6745



N-S STREET: Scottsdale Rd.      DATE: 03/20/18      LOCATION: Scottsdale  
 E-W STREET: Goldwater Blvd.      DAY: TUESDAY      PROJECT#: 18-1152-006

LANES:	NORTHBOUND			SOUTHBOUND			EASTBOUND			WESTBOUND			TOTAL
	NL	NT	NR	SL	ST	SR	EL	ET	ER	WL	WT	WR	
	1	0.5	0.5	1.3	0.3	0.3	1	2	0	1	3	0	
6:00 AM													
6:15 AM													
6:30 AM													
6:45 AM													
7:00 AM	1	0	1	30	3	1	7	68	7	13	56	0	187
7:15 AM	1	0	1	39	2	0	8	90	9	6	82	0	238
7:30 AM	1	1	3	55	5	3	4	103	6	12	88	0	281
7:45 AM	2	2	0	47	3	2	6	118	7	7	109	0	303
8:00 AM	4	1	3	54	2	3	9	102	5	12	85	0	280
8:15 AM	3	2	4	69	3	3	11	75	8	11	79	0	268
8:30 AM	3	1	2	55	7	1	8	93	5	16	94	0	285
8:45 AM	1	2	2	67	1	2	6	85	10	7	85	0	268
9:00 AM													
9:15 AM													
9:30 AM													
9:45 AM													
10:00 AM													
10:15 AM													
10:30 AM													
10:45 AM													
11:00 AM													
11:15 AM													
11:30 AM													
11:45 AM													

TOTAL	NL	NT	NR	SL	ST	SR	EL	ET	ER	WL	WT	WR	TOTAL
Volumes	16	9	16	416	26	15	59	734	57	84	678	0	2110
Approach %	39.02	21.95	39.02	91.03	5.69	3.28	6.94	86.35	6.71	11.02	88.98	0.00	
App/Depart	41	/	68	457	/	167	850	/	1166	762	/	709	

AM Peak Hr Begins at: 745 AM

**PEAK**

Volumes	12	6	9	225	15	9	34	388	25	46	367	0	1136
Approach %	44.44	22.22	33.33	90.36	6.02	3.61	7.61	86.80	5.59	11.14	88.86	0.00	

**PEAK HR.**

FACTOR:	0.750	0.830	0.853	0.890	0.937
---------	-------	-------	-------	-------	-------

CONTROL: Signal  
 COMMENT 1:  
 GPS: 33.489136, -111.926686





**FIELD DATA SERVICES OF ARIZONA, INC.**  
520.316.6745



veracitytrafficgroup

### Pedestrian & Bicycle Study

**N-S STREET:** Scottsdale Rd.  
**E-W STREET:** Goldwater Blvd.

**Date:** 03/20/18  
**Day:** TUESDAY

**City:** Scottsdale  
**Project #:** 18-1152-006

	PEDESTRIANS			
	N-LEG	S-LEG	E-LEG	W-LEG
7:00 AM	0	0	0	0
7:15 AM	0	0	0	0
7:30 AM	0	2	0	1
7:45 AM	0	1	0	4
8:00 AM	0	0	0	1
8:15 AM	1	2	4	3
8:30 AM	0	0	0	3
8:45 AM	2	4	2	4
<b>TOTAL</b>	<b>3</b>	<b>9</b>	<b>6</b>	<b>16</b>

	BICYCLES			
	N-LEG	S-LEG	E-LEG	W-LEG
7:00 AM	0	0	0	0
7:15 AM	0	0	0	0
7:30 AM	0	0	0	0
7:45 AM	0	0	0	0
8:00 AM	0	0	0	0
8:15 AM	0	0	0	0
8:30 AM	0	0	0	0
8:45 AM	0	0	0	1
<b>TOTAL</b>	<b>0</b>	<b>0</b>	<b>0</b>	<b>1</b>

	PEDESTRIANS			
	N-LEG	S-LEG	E-LEG	W-LEG
4:00 PM	1	2	0	6
4:15 PM	2	1	3	5
4:30 PM	0	1	0	8
4:45 PM	0	4	0	3
5:00 PM	0	5	0	13
5:15 PM	0	2	0	6
5:30 PM	2	3	0	7
5:45 PM	0	3	0	6
<b>TOTAL</b>	<b>5</b>	<b>21</b>	<b>3</b>	<b>54</b>

	BICYCLES			
	N-LEG	S-LEG	E-LEG	W-LEG
4:00 PM	0	1	0	0
4:15 PM	0	0	0	1
4:30 PM	2	0	3	0
4:45 PM	0	2	0	2
5:00 PM	0	1	0	0
5:15 PM	0	0	0	0
5:30 PM	0	3	2	1
5:45 PM	0	0	0	0
<b>TOTAL</b>	<b>2</b>	<b>7</b>	<b>5</b>	<b>4</b>

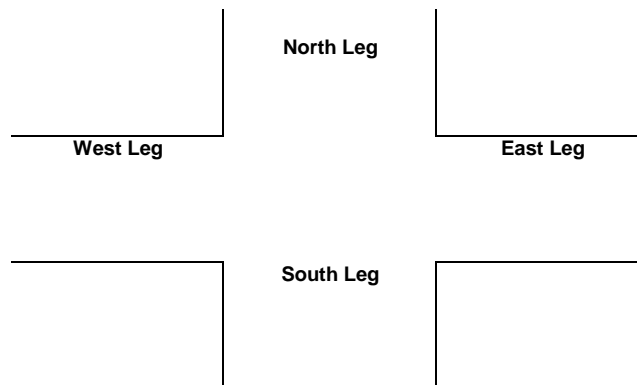

AM Peak Hour: 7:45am - 8:45am (2/21/19)

PM Peak Hour: 4:45pm - 5:45pm (2/20/19)

Goldwater Boulevard and Bishop Lane (6)

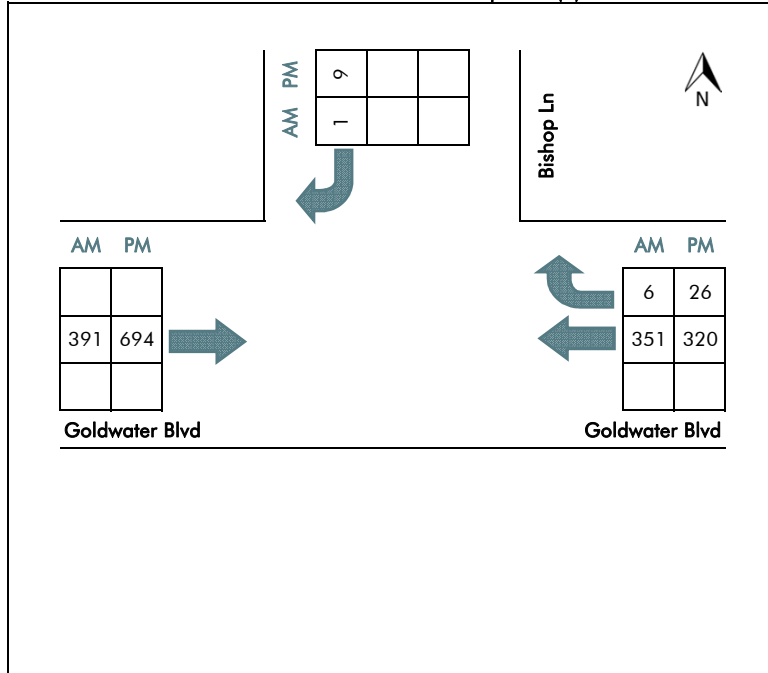

2nd Street and Bishop Lane (8)

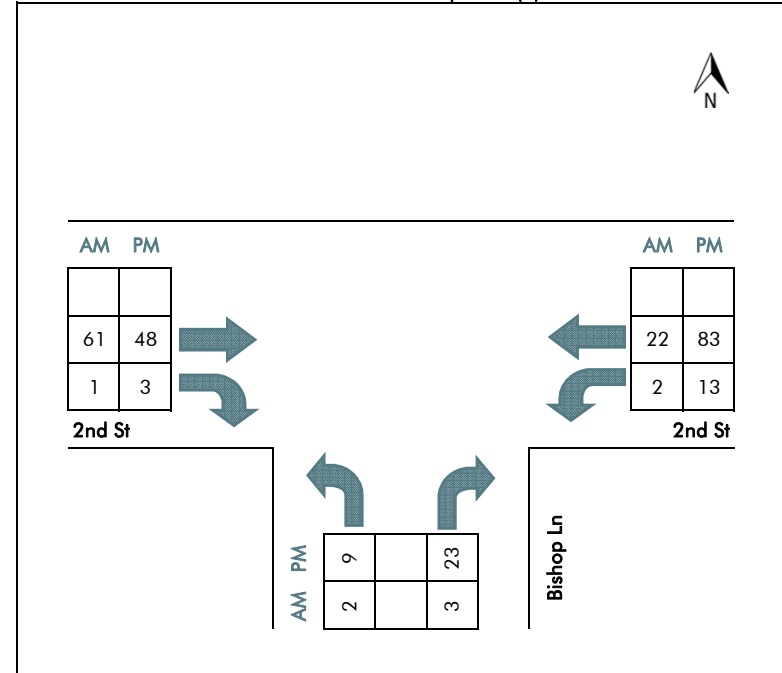

**Prepared by: Field Data Services of Arizona/Veracity Traffic Group (520) 316-6745**

Volumes for: Tuesday, March 20, 2018

City: Scottsdale

Project #: 18-1152-014

Location: 2nd St. east of Bishop Ln.

AM Period	NB	SB	EB	WB	PM Period	NB	SB	EB	WB			
00:00			1	2	12:00			23	20			
00:15			3	1	12:15			28	20			
00:30			1	1	12:30			27	17			
00:45			0	5	0	4	9	38	116	6	63	179
01:00			0	1	13:00			35	10			
01:15			1	0	13:15			32	16			
01:30			0	1	13:30			25	17			
01:45			0	1	0	2	3	15	107	14	57	164
02:00			1	0	14:00			27	20			
02:15			0	0	14:15			17	16			
02:30			0	0	14:30			23	17			
02:45			0	1	0	0	1	28	95	16	69	164
03:00			1	1	15:00			20	17			
03:15			0	0	15:15			19	19			
03:30			0	0	15:30			35	8			
03:45			1	2	2	3	5	23	97	23	67	164
04:00			0	0	16:00			28	31			
04:15			0	1	16:15			20	20			
04:30			1	0	16:30			34	13			
04:45			3	4	1	2	6	20	102	17	81	183
05:00			1	2	17:00			27	27			
05:15			2	0	17:15			36	18			
05:30			1	0	17:30			41	18			
05:45			0	4	0	2	6	36	140	16	79	219
06:00			2	0	18:00			16	28			
06:15			8	0	18:15			22	11			
06:30			5	0	18:30			29	15			
06:45			10	25	1	1	26	21	88	15	69	157
07:00			10	1	19:00			17	15			
07:15			12	4	19:15			22	26			
07:30			14	3	19:30			27	16			
07:45			17	53	5	13	66	16	82	14	71	153
08:00			10	3	20:00			19	23			
08:15			8	6	20:15			15	4			
08:30			15	2	20:30			8	8			
08:45			20	53	8	19	72	16	58	11	46	104
09:00			13	6	21:00			20	13			
09:15			16	0	21:15			13	10			
09:30			22	3	21:30			10	7			
09:45			22	73	13	22	95	11	54	11	41	95
10:00			24	13	22:00			6	6			
10:15			15	6	22:15			6	4			
10:30			21	7	22:30			8	3			
10:45			22	82	13	39	121	5	25	4	17	42
11:00			21	16	23:00			8	2			
11:15			15	15	23:15			5	3			
11:30			22	26	23:30			2	2			
11:45			23	81	18	75	156	1	16	4	11	27

**Total Vol.** 384 182 566 980 671 1651

GPS Coordinates: 33.491294, -111.926959

**Daily Totals**

NB	SB	EB	WB	Combined
		1364	853	2217

**AM**

**PM**

Split %	67.8%	32.2%	25.5%	59.4%	40.6%	74.5%
Peak Hour	11:45	11:30	11:30	17:00	15:45	17:00
Volume	101	84	180	140	87	219
P.H.F.	0.90	0.81	0.94	0.85	0.70	0.93

# Prepared by: Field Data Services of Arizona/Veracity Traffic Group (520) 316-6745

Volumes for: Tuesday, March 20, 2018

City: Scottsdale

Project #: 18-1152-015

Location: Goldwater Blvd. west of Bishop Ln.

AM Period	NB	SB	EB	WB	PM Period	NB	SB	EB	WB			
00:00			5	11	12:00			111	74			
00:15			5	12	12:15			113	69			
00:30			1	9	12:30			114	88			
00:45			4	15	5	37	52	107	445	94	325	770
01:00			1	11	13:00			129	84			
01:15			3	6	13:15			108	61			
01:30			1	8	13:30			111	95			
01:45			1	6	4	29	35	124	472	90	330	802
02:00			2	3	14:00			111	75			
02:15			2	1	14:15			99	82			
02:30			3	4	14:30			137	61			
02:45			2	9	3	11	20	131	478	82	300	778
03:00			2	3	15:00			113	71			
03:15			0	3	15:15			127	87			
03:30			1	4	15:30			131	91			
03:45			5	8	4	14	22	140	511	91	340	851
04:00			6	3	16:00			165	96			
04:15			5	4	16:15			183	103			
04:30			6	8	16:30			171	89			
04:45			18	35	8	23	58	169	688	88	376	1064
05:00			9	7	17:00			185	87			
05:15			18	19	17:15			197	96			
05:30			11	10	17:30			184	78			
05:45			16	54	36	72	126	173	739	76	337	1076
06:00			20	33	18:00			154	101			
06:15			26	40	18:15			128	81			
06:30			38	45	18:30			127	74			
06:45			54	138	59	177	315	100	509	73	329	838
07:00			72	57	19:00			116	45			
07:15			89	76	19:15			85	44			
07:30			96	82	19:30			101	34			
07:45			130	387	113	328	715	70	372	28	151	523
08:00			103	89	20:00			90	38			
08:15			96	99	20:15			76	52			
08:30			99	84	20:30			74	40			
08:45			100	398	86	358	756	64	304	35	165	469
09:00			81	94	21:00			58	30			
09:15			71	70	21:15			60	42			
09:30			74	89	21:30			56	17			
09:45			76	302	96	349	651	56	230	31	120	350
10:00			78	78	22:00			49	15			
10:15			70	89	22:15			50	12			
10:30			64	82	22:30			23	23			
10:45			71	283	78	327	610	22	144	14	64	208
11:00			63	87	23:00			31	13			
11:15			62	92	23:15			21	12			
11:30			69	116	23:30			11	15			
11:45			81	275	130	425	700	13	76	6	46	122

**Total Vol.** 1910 2150 **4060** 4968 2883 **7851**

GPS Coordinates: 33.489650, -111.927726

**Daily Totals**

NB	SB	EB	WB	Combined
		6878	5033	<b>11911</b>

**AM**

**PM**

Split %	47.0%	53.0%	<b>34.1%</b>	63.3%	36.7%	<b>65.9%</b>
<b>Peak Hour</b>	07:45	11:00	<b>07:45</b>	17:00	15:30	<b>16:45</b>
<b>Volume</b>	428	425	<b>813</b>	739	381	<b>1084</b>
<b>P.H.F.</b>	0.82	0.82	<b>0.84</b>	0.94	0.92	<b>0.92</b>

# ATTACHMENT D – CITY OF SCOTTSDALE SIGNAL TIMING

# Timings

## 178: GOLDWATER BLVD #2 & SCOTTSDALE RD

05/17/2018

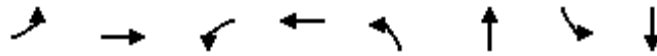

Lane Group	EBL	EBT	WBL	WBT	NBL	NBT	SBL	SBT
Lane Configurations	↘	↗	↘	↔	↘	↕	↘	↕↕
Traffic Volume (vph)	4	5	195	10	46	306	35	346
Future Volume (vph)	4	5	195	10	46	306	35	346
Turn Type	Split	NA	Split	NA	Perm	NA	Perm	NA
Protected Phases	8	8	4	4		6		2
Permitted Phases					6		2	
Detector Phase	8	8	4	4	6	6	2	2
Switch Phase								
Minimum Initial (s)	7.0	7.0	7.0	7.0	10.0	10.0	10.0	10.0
Minimum Split (s)	13.0	13.0	13.0	13.0	16.0	16.0	16.0	16.0
Total Split (s)	15.0	15.0	34.0	34.0	71.0	71.0	71.0	71.0
Total Split (%)	12.5%	12.5%	28.3%	28.3%	59.2%	59.2%	59.2%	59.2%
Yellow Time (s)	3.3	3.3	3.3	3.3	4.0	4.0	4.0	4.0
All-Red Time (s)	1.6	1.6	1.6	1.6	1.2	1.2	1.2	1.2
Lost Time Adjust (s)	0.0	0.0	0.0	0.0	0.0	0.0	0.0	0.0
Total Lost Time (s)	4.9	4.9	4.9	4.9	5.2	5.2	5.2	5.2
Lead/Lag	Lead	Lead	Lag	Lag				
Lead-Lag Optimize?								
Recall Mode	None	None	None	None	C-Max	C-Max	C-Max	C-Max
Act Effect Green (s)	7.6	7.6	15.2	15.2	89.4	89.4	89.4	89.4
Actuated g/C Ratio	0.06	0.06	0.13	0.13	0.74	0.74	0.74	0.74
v/c Ratio	0.04	0.10	0.57	0.57	0.08	0.14	0.05	0.11
Control Delay	52.8	54.3	58.1	56.9	3.7	2.9	15.5	12.1
Queue Delay	0.0	0.0	0.0	0.0	0.0	0.0	0.0	0.0
Total Delay	52.8	54.3	58.1	56.9	3.7	2.9	15.5	12.1
LOS	D	D	E	E	A	A	B	B
Approach Delay		53.8		57.5		3.0		12.4
Approach LOS		D		E		A		B

### Intersection Summary

Cycle Length: 120  
 Actuated Cycle Length: 120  
 Offset: 24 (20%), Referenced to phase 2:SBTL and 6:NBTL, Start of 1st Green  
 Natural Cycle: 45  
 Control Type: Actuated-Coordinated  
 Maximum v/c Ratio: 0.57  
 Intersection Signal Delay: 19.0  
 Intersection LOS: B  
 Intersection Capacity Utilization 42.1%  
 ICU Level of Service A  
 Analysis Period (min) 15

Splits and Phases: 178: GOLDWATER BLVD #2 & SCOTTSDALE RD

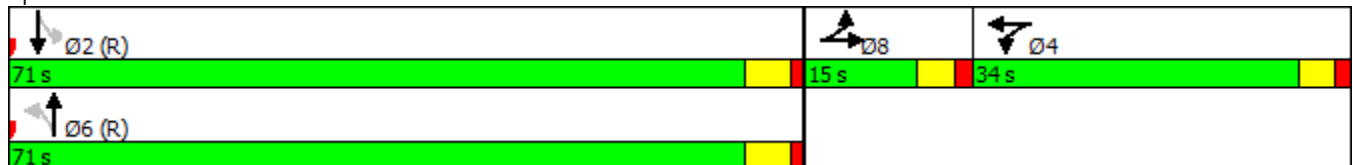

# Timings

## 195: GOLDWATER BLVD #2 & MAIN ST.

05/17/2018

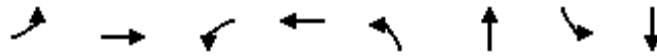

Lane Group	EBL	EBT	WBL	WBT	NBL	NBT	SBL	SBT
Lane Configurations		↕		↕	↙	↕	↙	↕↕↕
Traffic Volume (vph)	5	2	2	4	19	373	9	363
Future Volume (vph)	5	2	2	4	19	373	9	363
Turn Type	Perm	NA	Perm	NA	Perm	NA	Perm	NA
Protected Phases		8		4		6		2
Permitted Phases	8		4		6		2	
Detector Phase	8	8	4	4	6	6	2	2
Switch Phase								
Minimum Initial (s)	7.0	7.0	7.0	7.0	10.0	10.0	10.0	10.0
Minimum Split (s)	12.0	12.0	12.0	12.0	16.0	16.0	16.0	16.0
Total Split (s)	34.0	34.0	34.0	34.0	86.0	86.0	86.0	86.0
Total Split (%)	28.3%	28.3%	28.3%	28.3%	71.7%	71.7%	71.7%	71.7%
Yellow Time (s)	3.3	3.3	3.3	3.3	4.0	4.0	4.0	4.0
All-Red Time (s)	1.5	1.5	1.5	1.5	1.2	1.2	1.2	1.2
Lost Time Adjust (s)		0.0		0.0	0.0	0.0	0.0	0.0
Total Lost Time (s)		4.8		4.8	5.2	5.2	5.2	5.2
Lead/Lag								
Lead-Lag Optimize?								
Recall Mode	Ped	Ped	None	None	C-Max	C-Max	C-Max	C-Max
Act Effect Green (s)		29.0		29.0	81.0	81.0	81.0	81.0
Actuated g/C Ratio		0.24		0.24	0.68	0.68	0.68	0.68
v/c Ratio		0.06		0.03	0.04	0.20	0.02	0.14
Control Delay		35.6		35.3	2.5	3.1	6.6	7.0
Queue Delay		0.0		0.0	0.0	0.0	0.0	0.0
Total Delay		35.6		35.3	2.5	3.1	6.6	7.0
LOS		D		D	A	A	A	A
Approach Delay		35.6		35.3		3.0		6.9
Approach LOS		D		D		A		A

### Intersection Summary

Cycle Length: 120  
 Actuated Cycle Length: 120  
 Offset: 50 (42%), Referenced to phase 2:SBTL and 6:NBTL, Start of 1st Green  
 Natural Cycle: 40  
 Control Type: Actuated-Coordinated  
 Maximum v/c Ratio: 0.20  
 Intersection Signal Delay: 6.1  
 Intersection Capacity Utilization 30.0%  
 Analysis Period (min) 15  
 Intersection LOS: A  
 ICU Level of Service A

Splits and Phases: 195: GOLDWATER BLVD #2 & MAIN ST.



Timings

178: GOLDWATER BLVD #2 & SCOTTSDALE RD

05/17/2018

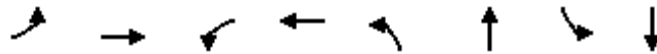

Lane Group	EBL	EBT	WBL	WBT	NBL	NBT	SBL	SBT
Lane Configurations	↘	↗	↘	↔	↘	↕	↘	↕
Traffic Volume (vph)	11	12	531	18	22	259	21	556
Future Volume (vph)	11	12	531	18	22	259	21	556
Turn Type	Split	NA	Split	NA	Perm	NA	Perm	NA
Protected Phases	8	8	4	4		6		2
Permitted Phases					6		2	
Detector Phase	8	8	4	4	6	6	2	2
Switch Phase								
Minimum Initial (s)	7.0	7.0	7.0	7.0	10.0	10.0	10.0	10.0
Minimum Split (s)	13.0	13.0	13.0	13.0	16.0	16.0	16.0	16.0
Total Split (s)	20.0	20.0	50.0	50.0	50.0	50.0	50.0	50.0
Total Split (%)	16.7%	16.7%	41.7%	41.7%	41.7%	41.7%	41.7%	41.7%
Yellow Time (s)	3.3	3.3	3.3	3.3	4.0	4.0	4.0	4.0
All-Red Time (s)	1.6	1.6	1.6	1.6	1.2	1.2	1.2	1.2
Lost Time Adjust (s)	0.0	0.0	0.0	0.0	0.0	0.0	0.0	0.0
Total Lost Time (s)	4.9	4.9	4.9	4.9	5.2	5.2	5.2	5.2
Lead/Lag	Lead	Lead	Lag	Lag				
Lead-Lag Optimize?								
Recall Mode	None	None	Ped	Ped	C-Max	C-Max	C-Max	C-Max
Act Effect Green (s)	8.8	8.8	33.0	33.0	67.9	67.9	67.9	67.9
Actuated g/C Ratio	0.07	0.07	0.28	0.28	0.57	0.57	0.57	0.57
v/c Ratio	0.11	0.28	0.69	0.69	0.06	0.15	0.04	0.21
Control Delay	51.8	56.9	47.6	47.0	5.5	4.8	13.4	12.0
Queue Delay	0.0	0.0	0.0	0.0	0.0	0.0	0.0	0.0
Total Delay	51.8	56.9	47.6	47.0	5.5	4.8	13.4	12.0
LOS	D	E	D	D	A	A	B	B
Approach Delay		55.5		47.3		4.9		12.0
Approach LOS		E		D		A		B

Intersection Summary

Cycle Length: 120  
 Actuated Cycle Length: 120  
 Offset: 88 (73%), Referenced to phase 2:SBTL and 6:NBTL, Start of 1st Green  
 Natural Cycle: 45  
 Control Type: Actuated-Coordinated  
 Maximum v/c Ratio: 0.69  
 Intersection Signal Delay: 25.5  
 Intersection Capacity Utilization 48.9%  
 Analysis Period (min) 15  
 Intersection LOS: C  
 ICU Level of Service A

Splits and Phases: 178: GOLDWATER BLVD #2 & SCOTTSDALE RD

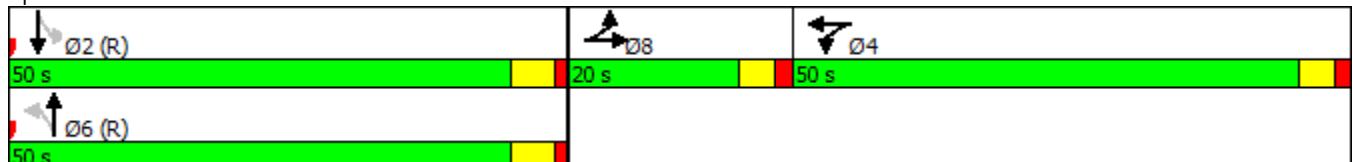

# Timings

## 195: GOLDWATER BLVD #2 & MAIN ST.

05/17/2018

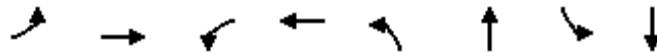

Lane Group	EBL	EBT	WBL	WBT	NBL	NBT	SBL	SBT
Lane Configurations		↕		↕	↙	↕	↙	↕↕↕
Traffic Volume (vph)	14	11	9	14	34	375	33	666
Future Volume (vph)	14	11	9	14	34	375	33	666
Turn Type	Perm	NA	Perm	NA	Perm	NA	Perm	NA
Protected Phases		8		4		6		2
Permitted Phases	8		4		6		2	
Detector Phase	8	8	4	4	6	6	2	2
Switch Phase								
Minimum Initial (s)	7.0	7.0	7.0	7.0	10.0	10.0	10.0	10.0
Minimum Split (s)	12.0	12.0	12.0	12.0	16.0	16.0	16.0	16.0
Total Split (s)	34.0	34.0	34.0	34.0	86.0	86.0	86.0	86.0
Total Split (%)	28.3%	28.3%	28.3%	28.3%	71.7%	71.7%	71.7%	71.7%
Yellow Time (s)	3.3	3.3	3.3	3.3	4.0	4.0	4.0	4.0
All-Red Time (s)	1.5	1.5	1.5	1.5	1.2	1.2	1.2	1.2
Lost Time Adjust (s)		0.0		0.0	0.0	0.0	0.0	0.0
Total Lost Time (s)		4.8		4.8	5.2	5.2	5.2	5.2
Lead/Lag								
Lead-Lag Optimize?								
Recall Mode	None	None	Ped	Ped	C-Max	C-Max	C-Max	C-Max
Act Effect Green (s)		29.0		29.0	81.0	81.0	81.0	81.0
Actuated g/C Ratio		0.24		0.24	0.68	0.68	0.68	0.68
v/c Ratio		0.11		0.14	0.11	0.20	0.07	0.26
Control Delay		36.5		37.0	4.4	5.0	7.1	7.7
Queue Delay		0.0		0.0	0.0	0.0	0.0	0.0
Total Delay		36.5		37.0	4.4	5.0	7.1	7.7
LOS		D		D	A	A	A	A
Approach Delay		36.5		37.0		4.9		7.7
Approach LOS		D		D		A		A

### Intersection Summary

Cycle Length: 120  
 Actuated Cycle Length: 120  
 Offset: 114 (95%), Referenced to phase 2:SBTL and 6:NBTL, Start of 1st Green  
 Natural Cycle: 40  
 Control Type: Actuated-Coordinated  
 Maximum v/c Ratio: 0.26  
 Intersection Signal Delay: 8.6  
 Intersection Capacity Utilization 40.6%  
 Analysis Period (min) 15  
 Intersection LOS: A  
 ICU Level of Service A

Splits and Phases: 195: GOLDWATER BLVD #2 & MAIN ST.

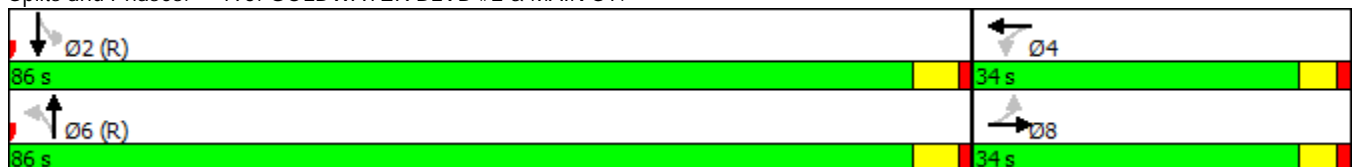

## ATTACHMENT E – EXISTING CAPACITY ANALYSIS

Some of the Synchro outputs under Attachment E are taken directly from the Museum Square Traffic Impact & Mitigation Analysis, dated August 10, 2018. For organizational purposes, the intersections for the Museum Square Traffic Impact & Mitigation Analysis have been changed to:

<b>Intersection</b>	<b>August 10, 2018 TI&amp;MA Intersection Number</b>	<b>2nd Street and Bishop TI&amp;MA Intersection Number</b>
Goldwater Boulevard and 2nd Street	12	1
Marshall Way and 2nd Street	16	2
Scottsdale Road and 2nd Street	17	3
Goldwater Boulevard and 70th Street	18	4
Goldwater Boulevard and Marshall Way	20	5
Goldwater Boulevard and Scottsdale Road	21	7

Intersection												
Int Delay, s/veh	2											
Movement	EBL	EBT	EBR	WBL	WBT	WBR	NBL	NBT	NBR	SBL	SBT	SBR
Lane Configurations		↕			↕		↕	↕		↕	↕	↕
Traffic Vol, veh/h	17	27	14	1	6	21	10	412	8	34	450	17
Future Vol, veh/h	17	27	14	1	6	21	10	412	8	34	450	17
Conflicting Peds, #/hr	3	0	0	0	0	3	3	0	1	1	0	3
Sign Control	Stop	Stop	Stop	Stop	Stop	Stop	Free	Free	Free	Free	Free	Free
RT Channelized	-	-	None	-	-	None	-	-	None	-	-	None
Storage Length	-	-	-	-	-	-	130	-	-	85	-	-
Veh in Median Storage, #	-	0	-	-	0	-	-	0	-	-	0	-
Grade, %	-	0	-	-	0	-	-	0	-	-	0	-
Peak Hour Factor	88	88	88	88	88	88	88	88	88	88	88	88
Heavy Vehicles, %	2	2	2	2	2	2	2	2	2	2	2	2
Mvmt Flow	19	31	16	1	7	24	11	468	9	39	511	19

Major/Minor	Minor2		Minor1		Major1		Major2					
Conflicting Flow All	864	1102	268	793	1107	243	534	0	0	478	0	0
Stage 1	601	601	-	496	496	-	-	-	-	-	-	-
Stage 2	263	501	-	297	611	-	-	-	-	-	-	-
Critical Hdwy	6.99	6.54	7.14	6.99	6.54	6.94	5.34	-	-	4.14	-	-
Critical Hdwy Stg 1	7.34	5.54	-	6.54	5.54	-	-	-	-	-	-	-
Critical Hdwy Stg 2	6.54	5.54	-	6.74	5.54	-	-	-	-	-	-	-
Follow-up Hdwy	3.67	4.02	3.92	3.67	4.02	3.32	3.12	-	-	2.22	-	-
Pot Cap-1 Maneuver	289	219	*825	*322	217	758	943	-	-	1081	-	-
Stage 1	685	684	-	*508	544	-	-	-	-	-	-	-
Stage 2	694	541	-	*881	677	-	-	-	-	-	-	-
Platoon blocked, %	1	1	1	1	1	1	-	-	-	-	-	-
Mov Cap-1 Maneuver	262	208	*823	*270	206	755	943	-	-	1078	-	-
Mov Cap-2 Maneuver	262	208	-	*270	206	-	-	-	-	-	-	-
Stage 1	676	658	-	*502	537	-	-	-	-	-	-	-
Stage 2	654	534	-	*794	651	-	-	-	-	-	-	-

Approach	EB		WB		NB		SB	
HCM Control Delay, s	22.3		13.4		0.2		0.6	
HCM LOS	C		B					

Minor Lane/Major Mvmt	NBL	NBT	NBR	EBLn1WBLn1	SBL	SBT	SBR
Capacity (veh/h)	943	-	-	274	462	1078	-
HCM Lane V/C Ratio	0.012	-	-	0.241	0.069	0.036	-
HCM Control Delay (s)	8.9	-	-	22.3	13.4	8.5	-
HCM Lane LOS	A	-	-	C	B	A	-
HCM 95th %tile Q(veh)	0	-	-	0.9	0.2	0.1	-





















Notes  
 ~: Volume exceeds capacity    \$: Delay exceeds 300s    +: Computation Not Defined    \*: All major volume in platoon

Intersection	
Intersection Delay, s/veh	7.3
Intersection LOS	A

Movement	EBL	EBT	EBR	WBL	WBT	WBR	NBL	NBT	NBR	SBL	SBT	SBR
Lane Configurations		↕			↕			↕			↕	
Traffic Vol, veh/h	7	53	8	2	18	2	6	1	6	2	8	5
Future Vol, veh/h	7	53	8	2	18	2	6	1	6	2	8	5
Peak Hour Factor	0.73	0.73	0.73	0.73	0.73	0.73	0.73	0.73	0.73	0.73	0.73	0.73
Heavy Vehicles, %	2	2	2	2	2	2	2	2	2	2	2	2
Mvmt Flow	10	73	11	3	25	3	8	1	8	3	11	7
Number of Lanes	0	1	0	0	1	0	0	1	0	0	1	0

Approach	EB	WB	NB	SB
Opposing Approach	WB	EB	SB	NB
Opposing Lanes	1	1	1	1
Conflicting Approach Left	SB	NB	EB	WB
Conflicting Lanes Left	1	1	1	1
Conflicting Approach Right	NB	SB	WB	EB
Conflicting Lanes Right	1	1	1	1
HCM Control Delay	7.5	7.2	7.1	7.1
HCM LOS	A	A	A	A

Lane	NBLn1	EBLn1	WBLn1	SBLn1
Vol Left, %	46%	10%	9%	13%
Vol Thru, %	8%	78%	82%	53%
Vol Right, %	46%	12%	9%	33%
Sign Control	Stop	Stop	Stop	Stop
Traffic Vol by Lane	13	68	22	15
LT Vol	6	7	2	2
Through Vol	1	53	18	8
RT Vol	6	8	2	5
Lane Flow Rate	18	93	30	21
Geometry Grp	1	1	1	1
Degree of Util (X)	0.02	0.103	0.034	0.023
Departure Headway (Hd)	3.979	3.973	4.034	3.989
Convergence, Y/N	Yes	Yes	Yes	Yes
Cap	892	902	885	891
Service Time	2.036	1.997	2.069	2.044
HCM Lane V/C Ratio	0.02	0.103	0.034	0.024
HCM Control Delay	7.1	7.5	7.2	7.1
HCM Lane LOS	A	A	A	A
HCM 95th-tile Q	0.1	0.3	0.1	0.1

												
Movement	EBL	EBT	EBR	WBL	WBT	WBR	NBL	NBT	NBR	SBL	SBT	SBR
Lane Configurations												
Traffic Volume (veh/h)	10	32	10	3	13	17	12	335	35	18	262	22
Future Volume (veh/h)	10	32	10	3	13	17	12	335	35	18	262	22
Number	3	8	18	7	4	14	1	6	16	5	2	12
Initial Q (Qb), veh	0	0	0	0	0	0	0	0	0	0	0	0
Ped-Bike Adj(A_pbT)	0.98		0.98	0.98		0.98	1.00		1.00	1.00		1.00
Parking Bus, Adj	1.00	1.00	0.90	1.00	1.00	1.00	1.00	1.00	1.00	1.00	1.00	1.00
Adj Sat Flow, veh/h/ln	1863	1863	1863	1900	1863	1900	1863	1863	1900	1863	1863	1900
Adj Flow Rate, veh/h	10	33	10	3	14	18	12	349	36	19	273	23
Adj No. of Lanes	1	1	1	0	1	0	1	2	0	1	2	0
Peak Hour Factor	0.96	0.96	0.96	0.96	0.96	0.96	0.96	0.96	0.96	0.96	0.96	0.96
Percent Heavy Veh, %	2	2	2	2	2	2	2	2	2	2	2	2
Cap, veh/h	225	135	101	71	52	62	934	2450	251	841	2499	209
Arrive On Green	0.07	0.07	0.07	0.07	0.07	0.07	0.76	0.76	0.76	1.00	1.00	1.00
Sat Flow, veh/h	1343	1863	1399	82	725	854	1076	3240	332	993	3306	277
Grp Volume(v), veh/h	10	33	10	35	0	0	12	190	195	19	145	151
Grp Sat Flow(s),veh/h/ln	1343	1863	1399	1661	0	0	1076	1770	1803	993	1770	1813
Q Serve(g_s), s	0.0	1.0	0.4	0.0	0.0	0.0	0.2	1.8	1.8	0.0	0.0	0.0
Cycle Q Clear(g_c), s	0.3	1.0	0.4	1.2	0.0	0.0	0.2	1.8	1.8	1.8	0.0	0.0
Prop In Lane	1.00		1.00	0.09		0.51	1.00		0.18	1.00		0.15
Lane Grp Cap(c), veh/h	225	135	101	185	0	0	934	1338	1363	841	1338	1371
V/C Ratio(X)	0.04	0.24	0.10	0.19	0.00	0.00	0.01	0.14	0.14	0.02	0.11	0.11
Avail Cap(c_a), veh/h	616	677	508	662	0	0	934	1338	1363	841	1338	1371
HCM Platoon Ratio	1.00	1.00	1.00	1.00	1.00	1.00	1.00	1.00	1.00	2.00	2.00	2.00
Upstream Filter(I)	1.00	1.00	1.00	1.00	0.00	0.00	1.00	1.00	1.00	1.00	1.00	1.00
Uniform Delay (d), s/veh	26.0	26.3	26.0	26.4	0.0	0.0	1.8	2.0	2.0	0.0	0.0	0.0
Incr Delay (d2), s/veh	0.0	0.3	0.2	0.2	0.0	0.0	0.0	0.2	0.2	0.0	0.2	0.2
Initial Q Delay(d3),s/veh	0.0	0.0	0.0	0.0	0.0	0.0	0.0	0.0	0.0	0.0	0.0	0.0
%ile BackOfQ(50%),veh/ln	0.2	0.5	0.2	0.6	0.0	0.0	0.1	0.9	1.0	0.0	0.1	0.1
LnGrp Delay(d),s/veh	26.0	26.6	26.2	26.5	0.0	0.0	1.8	2.2	2.2	0.1	0.2	0.2
LnGrp LOS	C	C	C	C			A	A	A	A	A	A
Approach Vol, veh/h		53			35			397			315	
Approach Delay, s/veh		26.4			26.5			2.2			0.2	
Approach LOS		C			C			A			A	
Timer	1	2	3	4	5	6	7	8				
Assigned Phs		2		4		6		8				
Phs Duration (G+Y+Rc), s		50.5		9.5		50.5		9.5				
Change Period (Y+Rc), s		5.1		* 5.2		5.1		* 5.2				
Max Green Setting (Gmax), s		27.9		* 22		27.9		* 22				
Max Q Clear Time (g_c+I1), s		3.8		3.2		3.8		3.0				
Green Ext Time (p_c), s		0.2		0.1		0.2		0.1				
<b>Intersection Summary</b>												
HCM 2010 Ctrl Delay			4.1									
HCM 2010 LOS			A									
<b>Notes</b>												

17: Scottsdale Road & 2nd Street

02/22/2019

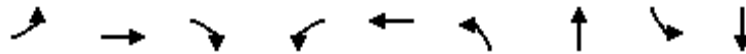

Lane Group	EBL	EBT	EBR	WBL	WBT	NBL	NBT	SBL	SBT
Lane Configurations	↙	↑	↘		↔	↙	↕	↙	↕
Traffic Volume (vph)	10	32	10	3	13	12	335	18	262
Future Volume (vph)	10	32	10	3	13	12	335	18	262
Turn Type	Perm	NA	Perm	Perm	NA	Perm	NA	Perm	NA
Protected Phases		8			4		6		2
Permitted Phases	8		8	4		6		2	
Detector Phase	8	8	8	4	4	6	6	2	2
Switch Phase									
Minimum Initial (s)	6.0	6.0	6.0	6.0	6.0	10.0	10.0	10.0	10.0
Minimum Split (s)	25.2	25.2	25.2	25.2	25.2	26.0	26.0	26.0	26.0
Total Split (s)	27.0	27.0	27.0	27.0	27.0	33.0	33.0	33.0	33.0
Total Split (%)	45.0%	45.0%	45.0%	45.0%	45.0%	55.0%	55.0%	55.0%	55.0%
Yellow Time (s)	3.0	3.0	3.0	3.0	3.0	3.0	3.0	3.0	3.0
All-Red Time (s)	2.2	2.2	2.2	2.2	2.2	2.1	2.1	2.1	2.1
Lost Time Adjust (s)	0.0	0.0	0.0		0.0	0.0	0.0	0.0	0.0
Total Lost Time (s)	5.2	5.2	5.2		5.2	5.1	5.1	5.1	5.1
Lead/Lag									
Lead-Lag Optimize?									
Recall Mode	None	None	None	None	None	C-Min	C-Min	C-Min	C-Min
Act Effct Green (s)	6.4	6.4	6.4		6.4	49.8	49.8	49.8	49.8
Actuated g/C Ratio	0.11	0.11	0.11		0.11	0.83	0.83	0.83	0.83
v/c Ratio	0.06	0.19	0.05		0.18	0.01	0.13	0.02	0.10
Control Delay	24.4	26.7	1.5		18.4	2.6	2.1	2.3	1.8
Queue Delay	0.0	0.0	0.0		0.0	0.0	0.0	0.0	0.0
Total Delay	24.4	26.7	1.5		18.4	2.6	2.1	2.3	1.8
LOS	C	C	A		B	A	A	A	A
Approach Delay		21.5			18.4		2.1		1.8
Approach LOS		C			B		A		A

Intersection Summary

Cycle Length: 60  
 Actuated Cycle Length: 60  
 Offset: 0 (0%), Referenced to phase 2:SBTL and 6:NBTL, Start of 1st Green  
 Natural Cycle: 55  
 Control Type: Actuated-Coordinated  
 Maximum v/c Ratio: 0.19  
 Intersection Signal Delay: 4.0  
 Intersection Capacity Utilization 41.7%  
 Analysis Period (min) 15

Intersection LOS: A  
 ICU Level of Service A

Splits and Phases: 17: Scottsdale Road & 2nd Street

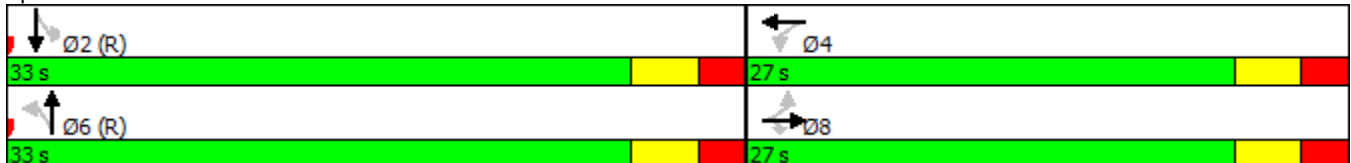





















Intersection						
Int Delay, s/veh	1.3					
Movement	SET	SER	NWL	NWT	NEL	NER
Lane Configurations	↑↑↑		↘	↑↑	↘	↘
Traffic Vol, veh/h	378	40	7	359	57	18
Future Vol, veh/h	378	40	7	359	57	18
Conflicting Peds, #/hr	0	8	8	0	2	0
Sign Control	Free	Free	Free	Free	Stop	Stop
RT Channelized	-	None	-	None	-	None
Storage Length	-	-	70	-	0	0
Veh in Median Storage, #	0	-	-	0	0	-
Grade, %	0	-	-	0	0	-
Peak Hour Factor	88	88	88	88	88	88
Heavy Vehicles, %	2	2	2	2	2	2
Mvmt Flow	430	45	8	408	65	20
Major/Minor	Major1	Major2	Minor1			
Conflicting Flow All	0	0	483	0	682	246
Stage 1	-	-	-	-	460	-
Stage 2	-	-	-	-	222	-
Critical Hdwy	-	-	5.34	-	6.29	7.14
Critical Hdwy Stg 1	-	-	-	-	6.64	-
Critical Hdwy Stg 2	-	-	-	-	5.84	-
Follow-up Hdwy	-	-	3.12	-	3.67	3.92
Pot Cap-1 Maneuver	-	-	690	-	413	643
Stage 1	-	-	-	-	526	-
Stage 2	-	-	-	-	765	-
Platoon blocked, %	-	-	-	-	-	-
Mov Cap-1 Maneuver	-	-	690	-	405	639
Mov Cap-2 Maneuver	-	-	-	-	405	-
Stage 1	-	-	-	-	522	-
Stage 2	-	-	-	-	755	-
Approach	SE	NW	NE			
HCM Control Delay, s	0	0.2	14.4			
HCM LOS			B			
Minor Lane/Major Mvmt	NELn1	NELn2	NWL	NWT	SET	SER
Capacity (veh/h)	405	639	690	-	-	-
HCM Lane V/C Ratio	0.16	0.032	0.012	-	-	-
HCM Control Delay (s)	15.6	10.8	10.3	-	-	-
HCM Lane LOS	C	B	B	-	-	-
HCM 95th %tile Q(veh)	0.6	0.1	0	-	-	-

Intersection												
Int Delay, s/veh	1.3											
Movement	EBL	EBT	EBR	WBL	WBT	WBR	NBL	NBT	NBR	SBL	SBT	SBR
Lane Configurations	↖ ↑↑↑			↖ ↑↑				↔		↖	↗	
Traffic Vol, veh/h	9	373	14	5	325	21	35	4	8	10	0	6
Future Vol, veh/h	9	373	14	5	325	21	35	4	8	10	0	6
Conflicting Peds, #/hr	0	0	3	3	0	0	5	0	2	2	0	5
Sign Control	Free	Free	Free	Free	Free	Free	Stop	Stop	Stop	Stop	Stop	Stop
RT Channelized	-	-	None	-	-	None	-	-	None	-	-	None
Storage Length	100	-	-	70	-	-	-	-	-	55	-	-
Veh in Median Storage, #	-	0	-	-	0	-	-	0	-	-	0	-
Grade, %	-	0	-	-	0	-	-	0	-	-	0	-
Peak Hour Factor	86	86	86	86	86	86	86	86	86	86	86	86
Heavy Vehicles, %	2	2	2	2	2	2	2	2	2	2	2	2
Mvmt Flow	10	434	16	6	378	24	41	5	9	12	0	7

Major/Minor	Major1			Major2			Minor1			Minor2		
Conflicting Flow All	402	0	0	453	0	0	672	880	230	601	876	206
Stage 1	-	-	-	-	-	-	466	466	-	402	402	-
Stage 2	-	-	-	-	-	-	206	414	-	199	474	-
Critical Hdwy	4.14	-	-	5.34	-	-	6.99	6.54	7.14	6.99	6.54	6.94
Critical Hdwy Stg 1	-	-	-	-	-	-	7.34	5.54	-	6.54	5.54	-
Critical Hdwy Stg 2	-	-	-	-	-	-	6.54	5.54	-	6.74	5.54	-
Follow-up Hdwy	2.22	-	-	3.12	-	-	3.67	4.02	3.92	3.67	4.02	3.32
Pot Cap-1 Maneuver	1153	-	-	713	-	-	368	284	658	408	286	800
Stage 1	-	-	-	-	-	-	477	561	-	576	599	-
Stage 2	-	-	-	-	-	-	748	591	-	747	556	-
Platoon blocked, %	-	-	-	-	-	-	-	-	-	-	-	-
Mov Cap-1 Maneuver	1148	-	-	712	-	-	358	278	655	391	280	797
Mov Cap-2 Maneuver	-	-	-	-	-	-	358	278	-	391	280	-
Stage 1	-	-	-	-	-	-	472	555	-	571	594	-
Stage 2	-	-	-	-	-	-	732	586	-	723	550	-

Approach	EB			WB			NB			SB		
HCM Control Delay, s	0.2			0.1			16.1			12.7		
HCM LOS							C			B		

Minor Lane/Major Mvmt	NBLn1	EBL	EBT	EBR	WBL	WBT	WBR	SBLn1	SBLn2
Capacity (veh/h)	378	1148	-	-	712	-	-	391	797
HCM Lane V/C Ratio	0.145	0.009	-	-	0.008	-	-	0.03	0.009
HCM Control Delay (s)	16.1	8.2	-	-	10.1	-	-	14.5	9.6
HCM Lane LOS	C	A	-	-	B	-	-	B	A
HCM 95th %tile Q(veh)	0.5	0	-	-	0	-	-	0.1	0

												
Movement	EBL	EBT	EBR	WBL	WBT	WBR	NBL	NBT	NBR	SBL	SBT	SBR
Lane Configurations												
Traffic Volume (veh/h)	11	6	8	209	14	8	43	341	0	32	361	23
Future Volume (veh/h)	11	6	8	209	14	8	43	341	0	32	361	23
Number	3	8	18	7	4	14	1	6	16	5	2	12
Initial Q (Qb), veh	0	0	0	0	0	0	0	0	0	0	0	0
Ped-Bike Adj(A_pbT)	1.00		0.94	1.00		1.00	1.00		1.00	1.00		1.00
Parking Bus, Adj	1.00	1.00	1.00	1.00	1.00	1.00	1.00	1.00	1.00	1.00	1.00	1.00
Adj Sat Flow, veh/h/ln	1863	1863	1900	1863	1863	1900	1863	1863	1900	1863	1863	1900
Adj Flow Rate, veh/h	12	6	9	241	0	0	46	363	0	34	384	24
Adj No. of Lanes	1	1	0	2	1	0	1	2	0	1	3	0
Peak Hour Factor	0.94	0.94	0.94	0.94	0.94	0.94	0.94	0.94	0.94	0.94	0.94	0.94
Percent Heavy Veh, %	2	2	2	2	2	2	2	2	2	2	2	2
Cap, veh/h	76	28	42	397	208	0	737	2549	0	758	3526	218
Arrive On Green	0.04	0.04	0.04	0.11	0.00	0.00	0.72	0.72	0.00	0.72	0.72	0.72
Sat Flow, veh/h	1774	649	973	3548	1863	0	973	3632	0	1014	4896	303
Grp Volume(v), veh/h	12	0	15	241	0	0	46	363	0	34	265	143
Grp Sat Flow(s),veh/h/ln	1774	0	1622	1774	1863	0	973	1770	0	1014	1695	1809
Q Serve(g_s), s	0.8	0.0	1.1	7.8	0.0	0.0	1.8	3.8	0.0	1.3	2.8	2.9
Cycle Q Clear(g_c), s	0.8	0.0	1.1	7.8	0.0	0.0	4.7	3.8	0.0	5.1	2.8	2.9
Prop In Lane	1.00		0.60	1.00		0.00	1.00		0.00	1.00		0.17
Lane Grp Cap(c), veh/h	76	0	70	397	208	0	737	2549	0	758	2441	1302
V/C Ratio(X)	0.16	0.00	0.21	0.61	0.00	0.00	0.06	0.14	0.00	0.04	0.11	0.11
Avail Cap(c_a), veh/h	149	0	137	860	452	0	737	2549	0	758	2441	1302
HCM Platoon Ratio	1.00	1.00	1.00	1.00	1.00	1.00	1.00	1.00	1.00	1.00	1.00	1.00
Upstream Filter(I)	1.00	0.00	1.00	1.00	0.00	0.00	1.00	1.00	0.00	1.00	1.00	1.00
Uniform Delay (d), s/veh	55.3	0.0	55.5	50.8	0.0	0.0	5.8	5.2	0.0	6.0	5.1	5.1
Incr Delay (d2), s/veh	0.4	0.0	0.6	0.6	0.0	0.0	0.2	0.1	0.0	0.1	0.1	0.2
Initial Q Delay(d3),s/veh	0.0	0.0	0.0	0.0	0.0	0.0	0.0	0.0	0.0	0.0	0.0	0.0
%ile BackOfQ(50%),veh/ln	0.4	0.0	0.5	3.8	0.0	0.0	0.5	1.9	0.0	0.4	1.4	1.5
LnGrp Delay(d),s/veh	55.7	0.0	56.0	51.3	0.0	0.0	6.0	5.4	0.0	6.1	5.2	5.3
LnGrp LOS	E		E	D			A	A		A	A	A
Approach Vol, veh/h		27			241			409			442	
Approach Delay, s/veh		55.9			51.3			5.4			5.3	
Approach LOS		E			D			A			A	
Timer	1	2	3	4	5	6	7	8				
Assigned Phs		2		4		6		8				
Phs Duration (G+Y+Rc), s		91.6		18.3		91.6		10.1				
Change Period (Y+Rc), s		* 5.2		* 4.9		* 5.2		4.9				
Max Green Setting (Gmax), s		* 66		* 29		* 66		10.1				
Max Q Clear Time (g_c+I1), s		7.1		9.8		6.7		3.1				
Green Ext Time (p_c), s		1.5		0.4		1.5		0.0				
<b>Intersection Summary</b>												
HCM 2010 Ctrl Delay			16.5									
HCM 2010 LOS			B									
<b>Notes</b>												

21: Goldwater Boulevard & Driveway/Scottsdale Road

02/22/2019

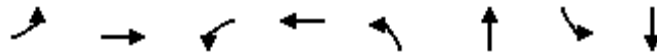

Lane Group	EBL	EBT	WBL	WBT	NBL	NBT	SBL	SBT
Lane Configurations								
Traffic Volume (vph)	11	6	209	14	43	341	32	361
Future Volume (vph)	11	6	209	14	43	341	32	361
Turn Type	Split	NA	Split	NA	Perm	NA	Perm	NA
Protected Phases	8	8	4	4		6		2
Permitted Phases					6		2	
Detector Phase	8	8	4	4	6	6	2	2
Switch Phase								
Minimum Initial (s)	7.0	7.0	7.0	7.0	10.0	10.0	10.0	10.0
Minimum Split (s)	13.0	13.0	13.0	13.0	16.0	16.0	16.0	16.0
Total Split (s)	15.0	15.0	34.0	34.0	71.0	71.0	71.0	71.0
Total Split (%)	12.5%	12.5%	28.3%	28.3%	59.2%	59.2%	59.2%	59.2%
Yellow Time (s)	3.3	3.3	3.3	3.3	4.0	4.0	4.0	4.0
All-Red Time (s)	1.6	1.6	1.6	1.6	1.2	1.2	1.2	1.2
Lost Time Adjust (s)	0.0	0.0	0.0	0.0	0.0	0.0	0.0	0.0
Total Lost Time (s)	4.9	4.9	4.9	4.9	5.2	5.2	5.2	5.2
Lead/Lag	Lead	Lead	Lag	Lag				
Lead-Lag Optimize?								
Recall Mode	None	None	None	None	C-Max	C-Max	C-Max	C-Max
Act Effct Green (s)	7.6	7.6	15.2	15.2	86.9	86.9	86.9	86.9
Actuated g/C Ratio	0.06	0.06	0.13	0.13	0.72	0.72	0.72	0.72
v/c Ratio	0.11	0.14	0.58	0.58	0.07	0.14	0.05	0.11
Control Delay	54.5	55.6	55.5	54.4	3.6	2.8	8.7	6.7
Queue Delay	0.0	0.0	0.0	0.0	0.0	0.0	0.0	0.0
Total Delay	54.5	55.6	55.5	54.4	3.6	2.8	8.7	6.7
LOS	D	E	E	D	A	A	A	A
Approach Delay		55.1		55.0		2.9		6.8
Approach LOS		E		D		A		A

Intersection Summary

Cycle Length: 120  
 Actuated Cycle Length: 120  
 Offset: 24 (20%), Referenced to phase 2:SBTL and 6:NBTL, Start of 1st Green  
 Natural Cycle: 45  
 Control Type: Actuated-Coordinated  
 Maximum v/c Ratio: 0.58  
 Intersection Signal Delay: 17.1  
 Intersection Capacity Utilization 56.7%  
 Analysis Period (min) 15  
 Intersection LOS: B  
 ICU Level of Service B

Splits and Phases: 21: Goldwater Boulevard & Driveway/Scottsdale Road

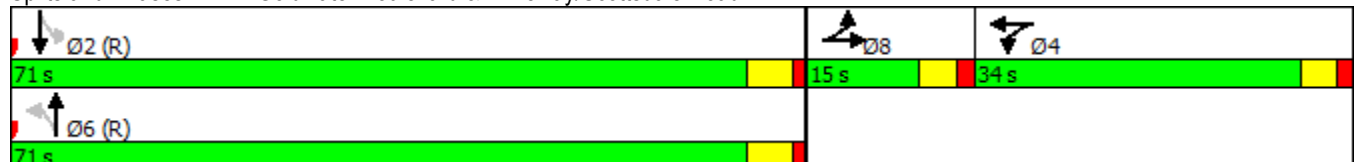

Intersection						
Int Delay, s/veh	0					
Movement	EBL	EBT	WBT	WBR	SBL	SBR
Lane Configurations		↑↑↑	↑↑			↑
Traffic Vol, veh/h	0	391	351	6	0	1
Future Vol, veh/h	0	391	351	6	0	1
Conflicting Peds, #/hr	0	0	0	0	0	0
Sign Control	Free	Free	Free	Free	Stop	Stop
RT Channelized	-	None	-	None	-	None
Storage Length	-	-	-	-	-	0
Veh in Median Storage, #	-	0	0	-	0	-
Grade, %	-	0	0	-	0	-
Peak Hour Factor	92	92	92	92	92	92
Heavy Vehicles, %	2	2	2	2	2	2
Mvmt Flow	0	425	382	7	0	1
Major/Minor	Major1	Major2	Minor2			
Conflicting Flow All	-	0	-	0	-	194
Stage 1	-	-	-	-	-	-
Stage 2	-	-	-	-	-	-
Critical Hdwy	-	-	-	-	-	6.94
Critical Hdwy Stg 1	-	-	-	-	-	-
Critical Hdwy Stg 2	-	-	-	-	-	-
Follow-up Hdwy	-	-	-	-	-	3.32
Pot Cap-1 Maneuver	0	-	-	-	0	815
Stage 1	0	-	-	-	0	-
Stage 2	0	-	-	-	0	-
Platoon blocked, %	-	-	-	-	-	-
Mov Cap-1 Maneuver	-	-	-	-	-	815
Mov Cap-2 Maneuver	-	-	-	-	-	-
Stage 1	-	-	-	-	-	-
Stage 2	-	-	-	-	-	-
Approach	EB	WB	SB			
HCM Control Delay, s	0	0	9.4			
HCM LOS						A
Minor Lane/Major Mvmt	EBT	WBT	WBR	SBLn1		
Capacity (veh/h)	-	-	-	815		
HCM Lane V/C Ratio	-	-	-	0.001		
HCM Control Delay (s)	-	-	-	9.4		
HCM Lane LOS	-	-	-	A		
HCM 95th %tile Q(veh)	-	-	-	0		

Intersection						
Int Delay, s/veh	0.6					
Movement	EBT	EBR	WBL	WBT	NBL	NBR
Lane Configurations						
Traffic Vol, veh/h	61	1	2	22	2	3
Future Vol, veh/h	61	1	2	22	2	3
Conflicting Peds, #/hr	0	0	0	0	0	0
Sign Control	Free	Free	Free	Free	Stop	Stop
RT Channelized	-	None	-	None	-	None
Storage Length	-	-	-	-	0	-
Veh in Median Storage, #	0	-	-	0	0	-
Grade, %	0	-	-	0	0	-
Peak Hour Factor	92	92	92	92	92	92
Heavy Vehicles, %	2	2	2	2	2	2
Mvmt Flow	66	1	2	24	2	3
Major/Minor	Major1	Major2	Minor1			
Conflicting Flow All	0	0	67	0	95	67
Stage 1	-	-	-	-	67	-
Stage 2	-	-	-	-	28	-
Critical Hdwy	-	-	4.12	-	6.42	6.22
Critical Hdwy Stg 1	-	-	-	-	5.42	-
Critical Hdwy Stg 2	-	-	-	-	5.42	-
Follow-up Hdwy	-	-	2.218	-	3.518	3.318
Pot Cap-1 Maneuver	-	-	1535	-	905	997
Stage 1	-	-	-	-	956	-
Stage 2	-	-	-	-	995	-
Platoon blocked, %	-	-	-	-	-	-
Mov Cap-1 Maneuver	-	-	1535	-	904	997
Mov Cap-2 Maneuver	-	-	-	-	904	-
Stage 1	-	-	-	-	956	-
Stage 2	-	-	-	-	994	-
Approach	EB	WB	NB			
HCM Control Delay, s	0	0.6	8.8			
HCM LOS				A		
Minor Lane/Major Mvmt	NBLn1	EBT	EBR	WBL	WBT	
Capacity (veh/h)	958	-	-	1535	-	
HCM Lane V/C Ratio	0.006	-	-	0.001	-	
HCM Control Delay (s)	8.8	-	-	7.3	0	
HCM Lane LOS	A	-	-	A	A	
HCM 95th %tile Q(veh)	0	-	-	0	-	

**Intersection**

Int Delay, s/veh 2.2

Movement	EBL	EBT	EBR	WBL	WBT	WBR	NBL	NBT	NBR	SBL	SBT	SBR
Lane Configurations		↕			↕		↕	↕		↕	↕	↕
Traffic Vol, veh/h	11	20	23	10	33	64	30	339	14	36	823	21
Future Vol, veh/h	11	20	23	10	33	64	30	339	14	36	823	21
Conflicting Peds, #/hr	0	0	0	0	0	0	2	0	2	1	0	2
Sign Control	Stop	Stop	Stop	Stop	Stop	Stop	Free	Free	Free	Free	Free	Free
RT Channelized	-	-	None	-	-	None	-	-	None	-	-	None
Storage Length	-	-	-	-	-	-	130	-	-	80	-	-
Veh in Median Storage, #	-	0	-	-	0	-	-	0	-	-	0	-
Grade, %	-	0	-	-	0	-	-	0	-	-	0	-
Peak Hour Factor	90	90	90	90	90	90	90	90	90	90	90	90
Heavy Vehicles, %	2	2	2	2	2	2	2	2	2	2	2	2
Mvmt Flow	12	22	26	11	37	71	33	377	16	40	914	23

Major/Minor	Minor2		Minor1		Major1		Major2					
Conflicting Flow All	1281	1469	471	910	1473	198	940	0	0	394	0	0
Stage 1	1008	1008	-	453	453	-	-	-	-	-	-	-
Stage 2	273	461	-	457	1020	-	-	-	-	-	-	-
Critical Hdwy	6.99	6.54	7.14	6.99	6.54	6.94	5.34	-	-	4.14	-	-
Critical Hdwy Stg 1	7.34	5.54	-	6.54	5.54	-	-	-	-	-	-	-
Critical Hdwy Stg 2	6.54	5.54	-	6.74	5.54	-	-	-	-	-	-	-
Follow-up Hdwy	3.67	4.02	3.92	3.67	4.02	3.32	3.12	-	-	2.22	-	-
Pot Cap-1 Maneuver	393	285	*738	420	283	810	857	-	-	1161	-	-
Stage 1	201	316	-	538	568	-	-	-	-	-	-	-
Stage 2	684	564	-	522	312	-	-	-	-	-	-	-
Platoon blocked, %	1	1	1	1	1	1	-	-	-	-	-	-
Mov Cap-1 Maneuver	302	264	*737	358	262	809	857	-	-	1161	-	-
Mov Cap-2 Maneuver	302	264	-	358	262	-	-	-	-	-	-	-
Stage 1	193	305	-	516	545	-	-	-	-	-	-	-
Stage 2	559	541	-	451	301	-	-	-	-	-	-	-

Approach	EB		WB		NB		SB	
HCM Control Delay, s	16.3		15.6		0.7		0.3	
HCM LOS	C		C					

Minor Lane/Major Mvmt	NBL	NBT	NBR	EBLn1WBLn1	SBL	SBT	SBR
Capacity (veh/h)	857	-	-	377	459	1161	-
HCM Lane V/C Ratio	0.039	-	-	0.159	0.259	0.034	-
HCM Control Delay (s)	9.4	-	-	16.3	15.6	8.2	-
HCM Lane LOS	A	-	-	C	C	A	-
HCM 95th %tile Q(veh)	0.1	-	-	0.6	1	0.1	-

**Notes**

~: Volume exceeds capacity    \$: Delay exceeds 300s    +: Computation Not Defined    \*: All major volume in platoon

**Intersection**

Intersection Delay, s/veh	7.5
Intersection LOS	A

Movement	EBL	EBT	EBR	WBL	WBT	WBR	NBL	NBT	NBR	SBL	SBT	SBR
Lane Configurations		↕			↕			↕			↕	
Traffic Vol, veh/h	5	37	6	6	74	3	8	4	4	7	27	16
Future Vol, veh/h	5	37	6	6	74	3	8	4	4	7	27	16
Peak Hour Factor	0.87	0.87	0.87	0.87	0.87	0.87	0.87	0.87	0.87	0.87	0.87	0.87
Heavy Vehicles, %	2	2	2	2	2	2	2	2	2	2	2	2
Mvmt Flow	6	43	7	7	85	3	9	5	5	8	31	18
Number of Lanes	0	1	0	0	1	0	0	1	0	0	1	0

Approach	EB	WB	NB	SB
Opposing Approach	WB	EB	SB	NB
Opposing Lanes	1	1	1	1
Conflicting Approach Left	SB	NB	EB	WB
Conflicting Lanes Left	1	1	1	1
Conflicting Approach Right	NB	SB	WB	EB
Conflicting Lanes Right	1	1	1	1
HCM Control Delay	7.4	7.7	7.4	7.4
HCM LOS	A	A	A	A

Lane	NBLn1	EBLn1	WBLn1	SBLn1
Vol Left, %	50%	10%	7%	14%
Vol Thru, %	25%	77%	89%	54%
Vol Right, %	25%	12%	4%	32%
Sign Control	Stop	Stop	Stop	Stop
Traffic Vol by Lane	16	48	83	50
LT Vol	8	5	6	7
Through Vol	4	37	74	27
RT Vol	4	6	3	16
Lane Flow Rate	18	55	95	57
Geometry Grp	1	1	1	1
Degree of Util (X)	0.021	0.063	0.109	0.065
Departure Headway (Hd)	4.189	4.084	4.1	4.044
Convergence, Y/N	Yes	Yes	Yes	Yes
Cap	842	870	869	875
Service Time	2.276	2.142	2.149	2.121
HCM Lane V/C Ratio	0.021	0.063	0.109	0.065
HCM Control Delay	7.4	7.4	7.7	7.4
HCM Lane LOS	A	A	A	A
HCM 95th-tile Q	0.1	0.2	0.4	0.2

Movement	EBL	EBT	EBR	WBL	WBT	WBR	NBL	NBT	NBR	SBL	SBT	SBR
Lane Configurations												
Traffic Volume (veh/h)	26	29	14	31	52	29	10	427	44	28	517	24
Future Volume (veh/h)	26	29	14	31	52	29	10	427	44	28	517	24
Number	3	8	18	7	4	14	1	6	16	5	2	12
Initial Q (Qb), veh	0	0	0	0	0	0	0	0	0	0	0	0
Ped-Bike Adj(A_pbT)	0.99		0.99	0.99		0.99	1.00		0.97	1.00		0.99
Parking Bus, Adj	1.00	1.00	0.90	1.00	1.00	1.00	1.00	1.00	1.00	1.00	1.00	1.00
Adj Sat Flow, veh/h/ln	1863	1863	1863	1900	1863	1900	1863	1863	1900	1863	1863	1900
Adj Flow Rate, veh/h	27	30	14	32	54	30	10	440	45	29	533	25
Adj No. of Lanes	1	1	1	0	1	0	1	2	0	1	2	0
Peak Hour Factor	0.97	0.97	0.97	0.97	0.97	0.97	0.97	0.97	0.97	0.97	0.97	0.97
Percent Heavy Veh, %	2	2	2	2	2	2	2	2	2	2	2	2
Cap, veh/h	272	182	138	110	85	42	737	2363	240	742	2514	118
Arrive On Green	0.10	0.10	0.10	0.10	0.10	0.10	0.73	0.73	0.73	1.00	1.00	1.00
Sat Flow, veh/h	1301	1863	1412	348	875	427	845	3234	329	904	3441	161
Grp Volume(v), veh/h	27	30	14	116	0	0	10	240	245	29	274	284
Grp Sat Flow(s),veh/h/ln	1301	1863	1412	1649	0	0	845	1770	1793	904	1770	1833
Q Serve(g_s), s	0.0	0.9	0.5	2.8	0.0	0.0	0.2	2.5	2.6	0.1	0.0	0.0
Cycle Q Clear(g_c), s	0.9	0.9	0.5	4.1	0.0	0.0	0.2	2.5	2.6	2.7	0.0	0.0
Prop In Lane	1.00		1.00	0.28		0.26	1.00		0.18	1.00		0.09
Lane Grp Cap(c), veh/h	272	182	138	238	0	0	737	1293	1310	742	1293	1339
V/C Ratio(X)	0.10	0.16	0.10	0.49	0.00	0.00	0.01	0.19	0.19	0.04	0.21	0.21
Avail Cap(c_a), veh/h	640	708	537	693	0	0	737	1293	1310	742	1293	1339
HCM Platoon Ratio	1.00	1.00	1.00	1.00	1.00	1.00	1.00	1.00	1.00	2.00	2.00	2.00
Upstream Filter(I)	1.00	1.00	1.00	1.00	0.00	0.00	1.00	1.00	1.00	0.99	0.99	0.99
Uniform Delay (d), s/veh	24.8	24.8	24.7	26.2	0.0	0.0	2.2	2.5	2.5	0.1	0.0	0.0
Incr Delay (d2), s/veh	0.1	0.2	0.1	0.6	0.0	0.0	0.0	0.3	0.3	0.1	0.4	0.4
Initial Q Delay(d3),s/veh	0.0	0.0	0.0	0.0	0.0	0.0	0.0	0.0	0.0	0.0	0.0	0.0
%ile BackOfQ(50%),veh/ln	0.4	0.5	0.2	1.9	0.0	0.0	0.1	1.3	1.3	0.0	0.1	0.1
LnGrp Delay(d),s/veh	24.9	25.0	24.8	26.8	0.0	0.0	2.2	2.8	2.8	0.2	0.4	0.4
LnGrp LOS	C	C	C	C			A	A	A	A	A	A
Approach Vol, veh/h		71			116			495			587	
Approach Delay, s/veh		24.9			26.8			2.8			0.4	
Approach LOS		C			C			A			A	
Timer	1	2	3	4	5	6	7	8				
Assigned Phs		2		4		6		8				
Phs Duration (G+Y+Rc), s		48.9		11.1		48.9		11.1				
Change Period (Y+Rc), s		5.1		* 5.2		5.1		* 5.2				
Max Green Setting (Gmax), s		26.9		* 23		26.9		* 23				
Max Q Clear Time (g_c+I1), s		4.7		6.1		4.6		2.9				
Green Ext Time (p_c), s		0.3		0.4		0.3		0.4				
<b>Intersection Summary</b>												
HCM 2010 Ctrl Delay			5.1									
HCM 2010 LOS			A									
<b>Notes</b>												

17: Scottsdale Road & 2nd Street

02/22/2019

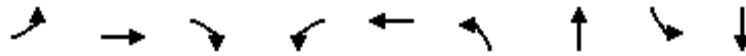

Lane Group	EBL	EBT	EBR	WBL	WBT	NBL	NBT	SBL	SBT
Lane Configurations									
Traffic Volume (vph)	26	29	14	31	52	10	427	28	517
Future Volume (vph)	26	29	14	31	52	10	427	28	517
Turn Type	Perm	NA	Perm	Perm	NA	Perm	NA	Perm	NA
Protected Phases		8			4		6		2
Permitted Phases	8		8	4		6		2	
Detector Phase	8	8	8	4	4	6	6	2	2
Switch Phase									
Minimum Initial (s)	6.0	6.0	6.0	6.0	6.0	10.0	10.0	10.0	10.0
Minimum Split (s)	25.2	25.2	25.2	25.2	25.2	26.0	26.0	26.0	26.0
Total Split (s)	28.0	28.0	28.0	28.0	28.0	32.0	32.0	32.0	32.0
Total Split (%)	46.7%	46.7%	46.7%	46.7%	46.7%	53.3%	53.3%	53.3%	53.3%
Yellow Time (s)	3.0	3.0	3.0	3.0	3.0	3.0	3.0	3.0	3.0
All-Red Time (s)	2.2	2.2	2.2	2.2	2.2	2.1	2.1	2.1	2.1
Lost Time Adjust (s)	0.0	0.0	0.0		0.0	0.0	0.0	0.0	0.0
Total Lost Time (s)	5.2	5.2	5.2		5.2	5.1	5.1	5.1	5.1
Lead/Lag									
Lead-Lag Optimize?									
Recall Mode	None	None	None	None	None	C-Min	C-Min	C-Min	C-Min
Act Effct Green (s)	8.0	8.0	8.0		8.0	44.9	44.9	44.9	44.9
Actuated g/C Ratio	0.13	0.13	0.13		0.13	0.75	0.75	0.75	0.75
v/c Ratio	0.16	0.13	0.06		0.48	0.02	0.19	0.04	0.21
Control Delay	23.8	23.0	3.3		24.9	2.4	1.9	2.8	2.5
Queue Delay	0.0	0.0	0.0		0.0	0.0	0.0	0.0	0.0
Total Delay	23.8	23.0	3.3		24.9	2.4	1.9	2.8	2.5
LOS	C	C	A		C	A	A	A	A
Approach Delay		19.4			24.9		1.9		2.5
Approach LOS		B			C		A		A

Intersection Summary

Cycle Length: 60  
 Actuated Cycle Length: 60  
 Offset: 0 (0%), Referenced to phase 2:SBTL and 6:NBTL, Start of 1st Green  
 Natural Cycle: 55  
 Control Type: Actuated-Coordinated  
 Maximum v/c Ratio: 0.48  
 Intersection Signal Delay: 5.3  
 Intersection Capacity Utilization 44.9%  
 Analysis Period (min) 15

Intersection LOS: A  
 ICU Level of Service A

Splits and Phases: 17: Scottsdale Road & 2nd Street

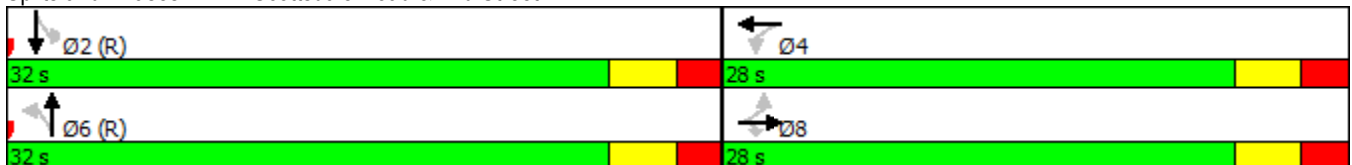

Intersection						
Int Delay, s/veh	1.6					
Movement	SET	SER	NWL	NWT	NEL	NER
Lane Configurations	↑↑↑		↘	↑↑	↘	↘
Traffic Vol, veh/h	701	152	23	313	60	13
Future Vol, veh/h	701	152	23	313	60	13
Conflicting Peds, #/hr	0	9	9	0	2	0
Sign Control	Free	Free	Free	Free	Stop	Stop
RT Channelized	-	None	-	None	-	None
Storage Length	-	-	70	-	0	0
Veh in Median Storage, #	0	-	-	0	0	-
Grade, %	0	-	-	0	0	-
Peak Hour Factor	94	94	94	94	94	94
Heavy Vehicles, %	2	2	2	2	2	2
Mvmt Flow	746	162	24	333	64	14

Major/Minor	Major1	Major2	Minor1		
Conflicting Flow All	0	0	916	0	1053
Stage 1	-	-	-	-	836
Stage 2	-	-	-	-	217
Critical Hdwy	-	-	5.34	-	6.29
Critical Hdwy Stg 1	-	-	-	-	6.64
Critical Hdwy Stg 2	-	-	-	-	5.84
Follow-up Hdwy	-	-	3.12	-	3.67
Pot Cap-1 Maneuver	-	-	430	-	254
Stage 1	-	-	-	-	312
Stage 2	-	-	-	-	769
Platoon blocked, %	-	-	-	-	-
Mov Cap-1 Maneuver	-	-	430	-	238
Mov Cap-2 Maneuver	-	-	-	-	238
Stage 1	-	-	-	-	310
Stage 2	-	-	-	-	725

Approach	SE	NW	NE
HCM Control Delay, s	0	0.9	23.4
HCM LOS			C

Minor Lane/Major Mvmt	NELn1	NELn2	NWL	NWT	SET	SER
Capacity (veh/h)	238	463	430	-	-	-
HCM Lane V/C Ratio	0.268	0.03	0.057	-	-	-
HCM Control Delay (s)	25.6	13	13.9	-	-	-
HCM Lane LOS	D	B	B	-	-	-
HCM 95th %tile Q(veh)	1	0.1	0.2	-	-	-

Intersection												
Int Delay, s/veh	1.5											
Movement	EBL	EBT	EBR	WBL	WBT	WBR	NBL	NBT	NBR	SBL	SBT	SBR
Lane Configurations	↖ ↑↑↑			↖ ↑↑				↔		↖ ↑		
Traffic Vol, veh/h	11	671	32	10	299	11	23	7	7	16	9	14
Future Vol, veh/h	11	671	32	10	299	11	23	7	7	16	9	14
Conflicting Peds, #/hr	3	0	12	12	0	3	8	0	1	1	0	8
Sign Control	Free	Free	Free	Free	Free	Free	Stop	Stop	Stop	Stop	Stop	Stop
RT Channelized	-	-	None	-	-	None	-	-	None	-	-	None
Storage Length	100	-	-	70	-	-	-	-	-	55	-	-
Veh in Median Storage, #	-	0	-	-	0	-	-	0	-	-	0	-
Grade, %	-	0	-	-	0	-	-	0	-	-	0	-
Peak Hour Factor	95	95	95	95	95	95	95	95	95	95	95	95
Heavy Vehicles, %	2	2	2	2	2	2	2	2	2	2	2	2
Mvmt Flow	12	706	34	11	315	12	24	7	7	17	9	15

Major/Minor	Major1			Major2			Minor1			Minor2		
Conflicting Flow All	329	0	0	752	0	0	949	1108	383	655	1120	174
Stage 1	-	-	-	-	-	-	758	758	-	345	345	-
Stage 2	-	-	-	-	-	-	191	350	-	310	775	-
Critical Hdwy	4.14	-	-	5.34	-	-	6.99	6.54	7.14	6.99	6.54	6.94
Critical Hdwy Stg 1	-	-	-	-	-	-	7.34	5.54	-	6.54	5.54	-
Critical Hdwy Stg 2	-	-	-	-	-	-	6.54	5.54	-	6.74	5.54	-
Follow-up Hdwy	2.22	-	-	3.12	-	-	3.67	4.02	3.92	3.67	4.02	3.32
Pot Cap-1 Maneuver	1227	-	-	515	-	-	242	209	525	377	205	839
Stage 1	-	-	-	-	-	-	300	413	-	622	635	-
Stage 2	-	-	-	-	-	-	763	631	-	640	406	-
Platoon blocked, %	-	-	-	-	-	-	-	-	-	-	-	-
Mov Cap-1 Maneuver	1219	-	-	515	-	-	220	200	519	352	196	831
Mov Cap-2 Maneuver	-	-	-	-	-	-	220	200	-	352	196	-
Stage 1	-	-	-	-	-	-	294	405	-	614	620	-
Stage 2	-	-	-	-	-	-	717	616	-	613	398	-

Approach	EB			WB			NB			SB		
HCM Control Delay, s	0.1			0.4			22.7			15.6		
HCM LOS							C			C		

Minor Lane/Major Mvmt	NBLn1	EBL	EBT	EBR	WBL	WBT	WBR	SBLn1	SBLn2
Capacity (veh/h)	242	1219	-	-	515	-	-	352	366
HCM Lane V/C Ratio	0.161	0.009	-	-	0.02	-	-	0.048	0.066
HCM Control Delay (s)	22.7	8	-	-	12.1	-	-	15.7	15.5
HCM Lane LOS	C	A	-	-	B	-	-	C	C
HCM 95th %tile Q(veh)	0.6	0	-	-	0.1	-	-	0.1	0.2

Movement	EBL	EBT	EBR	WBL	WBT	WBR	NBL	NBT	NBR	SBL	SBT	SBR
Lane Configurations												
Traffic Volume (veh/h)	13	6	11	548	21	19	20	285	0	21	676	20
Future Volume (veh/h)	13	6	11	548	21	19	20	285	0	21	676	20
Number	3	8	18	7	4	14	1	6	16	5	2	12
Initial Q (Qb), veh	0	0	0	0	0	0	0	0	0	0	0	0
Ped-Bike Adj(A_pbT)	1.00		0.86	1.00		1.00	1.00		1.00	1.00		0.97
Parking Bus, Adj	1.00	1.00	1.00	1.00	1.00	1.00	1.00	1.00	1.00	1.00	1.00	1.00
Adj Sat Flow, veh/h/ln	1863	1863	1900	1863	1863	1900	1863	1863	1900	1863	1863	1900
Adj Flow Rate, veh/h	15	7	13	675	0	0	23	331	0	24	786	23
Adj No. of Lanes	1	1	0	2	1	0	1	2	0	1	3	0
Peak Hour Factor	0.86	0.86	0.86	0.86	0.86	0.86	0.86	0.86	0.86	0.86	0.86	0.86
Percent Heavy Veh, %	2	2	2	2	2	2	2	2	2	2	2	2
Cap, veh/h	132	39	73	823	432	0	388	2013	0	605	2885	84
Arrive On Green	0.07	0.07	0.07	0.23	0.00	0.00	0.57	0.57	0.00	0.57	0.57	0.57
Sat Flow, veh/h	1774	527	979	3548	1863	0	670	3632	0	1040	5073	148
Grp Volume(v), veh/h	15	0	20	675	0	0	23	331	0	24	525	284
Grp Sat Flow(s),veh/h/ln	1774	0	1506	1774	1863	0	670	1770	0	1040	1695	1831
Q Serve(g_s), s	0.9	0.0	1.5	21.7	0.0	0.0	2.2	5.3	0.0	1.3	9.5	9.5
Cycle Q Clear(g_c), s	0.9	0.0	1.5	21.7	0.0	0.0	11.7	5.3	0.0	6.7	9.5	9.5
Prop In Lane	1.00		0.65	1.00		0.00	1.00		0.00	1.00		0.08
Lane Grp Cap(c), veh/h	132	0	112	823	432	0	388	2013	0	605	1928	1041
V/C Ratio(X)	0.11	0.00	0.18	0.82	0.00	0.00	0.06	0.16	0.00	0.04	0.27	0.27
Avail Cap(c_a), veh/h	223	0	190	1333	700	0	388	2013	0	605	1928	1041
HCM Platoon Ratio	1.00	1.00	1.00	1.00	1.00	1.00	1.00	1.00	1.00	1.00	1.00	1.00
Upstream Filter(I)	1.00	0.00	1.00	1.00	0.00	0.00	1.00	1.00	0.00	1.00	1.00	1.00
Uniform Delay (d), s/veh	51.8	0.0	52.1	43.7	0.0	0.0	16.2	12.3	0.0	13.9	13.2	13.2
Incr Delay (d2), s/veh	0.1	0.0	0.3	0.9	0.0	0.0	0.3	0.2	0.0	0.1	0.3	0.6
Initial Q Delay(d3),s/veh	0.0	0.0	0.0	0.0	0.0	0.0	0.0	0.0	0.0	0.0	0.0	0.0
%ile BackOfQ(50%),veh/ln	0.5	0.0	0.6	10.7	0.0	0.0	0.4	2.7	0.0	0.4	4.5	5.0
LnGrp Delay(d),s/veh	52.0	0.0	52.4	44.6	0.0	0.0	16.5	12.5	0.0	14.0	13.6	13.9
LnGrp LOS	D		D	D			B	B		B	B	B
Approach Vol, veh/h		35			675			354			833	
Approach Delay, s/veh		52.2			44.6			12.7			13.7	
Approach LOS		D			D			B			B	
Timer	1	2	3	4	5	6	7	8				
Assigned Phs		2		4		6		8				
Phs Duration (G+Y+Rc), s		73.4		32.7		73.4		13.8				
Change Period (Y+Rc), s		* 5.2		* 4.9		* 5.2		4.9				
Max Green Setting (Gmax), s		* 45		* 45		* 45		15.1				
Max Q Clear Time (g_c+I1), s		11.5		23.7		13.7		3.5				
Green Ext Time (p_c), s		2.1		1.4		2.1		0.0				
<b>Intersection Summary</b>												
HCM 2010 Ctrl Delay			25.2									
HCM 2010 LOS			C									
<b>Notes</b>												

21: Goldwater Boulevard & Driveway/Scottsdale Road

02/22/2019

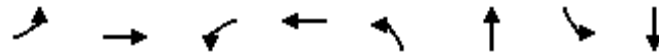

Lane Group	EBL	EBT	WBL	WBT	NBL	NBT	SBL	SBT
Lane Configurations								
Traffic Volume (vph)	13	6	548	21	20	285	21	676
Future Volume (vph)	13	6	548	21	20	285	21	676
Turn Type	Split	NA	Split	NA	Perm	NA	Perm	NA
Protected Phases	8	8	4	4		6		2
Permitted Phases					6		2	
Detector Phase	8	8	4	4	6	6	2	2
Switch Phase								
Minimum Initial (s)	7.0	7.0	7.0	7.0	10.0	10.0	10.0	10.0
Minimum Split (s)	13.0	13.0	13.0	13.0	16.0	16.0	16.0	16.0
Total Split (s)	20.0	20.0	50.0	50.0	50.0	50.0	50.0	50.0
Total Split (%)	16.7%	16.7%	41.7%	41.7%	41.7%	41.7%	41.7%	41.7%
Yellow Time (s)	3.3	3.3	3.3	3.3	4.0	4.0	4.0	4.0
All-Red Time (s)	1.6	1.6	1.6	1.6	1.2	1.2	1.2	1.2
Lost Time Adjust (s)	0.0	0.0	0.0	0.0	0.0	0.0	0.0	0.0
Total Lost Time (s)	4.9	4.9	4.9	4.9	5.2	5.2	5.2	5.2
Lead/Lag	Lead	Lead	Lag	Lag				
Lead-Lag Optimize?								
Recall Mode	None	None	Ped	Ped	C-Max	C-Max	C-Max	C-Max
Act Effct Green (s)	8.6	8.6	33.5	33.5	67.7	67.7	67.7	67.7
Actuated g/C Ratio	0.07	0.07	0.28	0.28	0.56	0.56	0.56	0.56
v/c Ratio	0.12	0.17	0.74	0.72	0.07	0.17	0.04	0.28
Control Delay	52.4	54.0	49.8	48.9	6.4	5.5	16.1	15.3
Queue Delay	0.0	0.0	0.0	0.0	0.0	0.0	0.0	0.0
Total Delay	52.4	54.0	49.8	48.9	6.4	5.5	16.1	15.3
LOS	D	D	D	D	A	A	B	B
Approach Delay		53.3		49.3		5.5		15.4
Approach LOS		D		D		A		B

Intersection Summary

Cycle Length: 120  
 Actuated Cycle Length: 120  
 Offset: 88 (73%), Referenced to phase 2:SBTL and 6:NBTL, Start of 1st Green  
 Natural Cycle: 50  
 Control Type: Actuated-Coordinated  
 Maximum v/c Ratio: 0.74  
 Intersection Signal Delay: 26.4  
 Intersection Capacity Utilization 52.5%  
 Analysis Period (min) 15

Intersection LOS: C  
 ICU Level of Service A

Splits and Phases: 21: Goldwater Boulevard & Driveway/Scottsdale Road

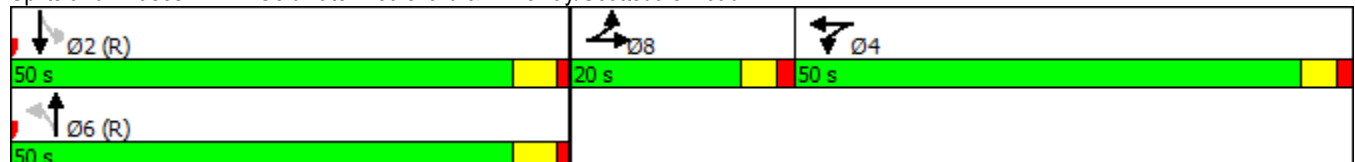

Intersection						
Int Delay, s/veh	0.1					
Movement	EBL	EBT	WBT	WBR	SBL	SBR
Lane Configurations		↑↑↑	↑↑			↑
Traffic Vol, veh/h	0	694	320	26	0	9
Future Vol, veh/h	0	694	320	26	0	9
Conflicting Peds, #/hr	0	0	0	0	0	0
Sign Control	Free	Free	Free	Free	Stop	Stop
RT Channelized	-	None	-	None	-	None
Storage Length	-	-	-	-	-	0
Veh in Median Storage, #	-	0	0	-	0	-
Grade, %	-	0	0	-	0	-
Peak Hour Factor	92	92	92	92	92	92
Heavy Vehicles, %	2	2	2	2	2	2
Mvmt Flow	0	754	348	28	0	10
Major/Minor	Major1	Major2	Minor2			
Conflicting Flow All	-	0	-	0	-	188
Stage 1	-	-	-	-	-	-
Stage 2	-	-	-	-	-	-
Critical Hdwy	-	-	-	-	-	6.94
Critical Hdwy Stg 1	-	-	-	-	-	-
Critical Hdwy Stg 2	-	-	-	-	-	-
Follow-up Hdwy	-	-	-	-	-	3.32
Pot Cap-1 Maneuver	0	-	-	-	0	822
Stage 1	0	-	-	-	0	-
Stage 2	0	-	-	-	0	-
Platoon blocked, %	-	-	-	-	-	-
Mov Cap-1 Maneuver	-	-	-	-	-	822
Mov Cap-2 Maneuver	-	-	-	-	-	-
Stage 1	-	-	-	-	-	-
Stage 2	-	-	-	-	-	-
Approach	EB	WB	SB			
HCM Control Delay, s	0	0	9.4			
HCM LOS				A		
Minor Lane/Major Mvmt	EBT	WBT	WBR	SBLn1		
Capacity (veh/h)	-	-	-	822		
HCM Lane V/C Ratio	-	-	-	0.012		
HCM Control Delay (s)	-	-	-	9.4		
HCM Lane LOS	-	-	-	A		
HCM 95th %tile Q(veh)	-	-	-	0		

Intersection						
Int Delay, s/veh	2.1					
Movement	EBT	EBR	WBL	WBT	NBL	NBR
Lane Configurations						
Traffic Vol, veh/h	48	3	13	83	9	23
Future Vol, veh/h	48	3	13	83	9	23
Conflicting Peds, #/hr	0	0	0	0	0	0
Sign Control	Free	Free	Free	Free	Stop	Stop
RT Channelized	-	None	-	None	-	None
Storage Length	-	-	-	-	0	-
Veh in Median Storage, #	0	-	-	0	0	-
Grade, %	0	-	-	0	0	-
Peak Hour Factor	92	92	92	92	92	92
Heavy Vehicles, %	2	2	2	2	2	2
Mvmt Flow	52	3	14	90	10	25
Major/Minor	Major1	Major2	Minor1			
Conflicting Flow All	0	0	55	0	172	54
Stage 1	-	-	-	-	54	-
Stage 2	-	-	-	-	118	-
Critical Hdwy	-	-	4.12	-	6.42	6.22
Critical Hdwy Stg 1	-	-	-	-	5.42	-
Critical Hdwy Stg 2	-	-	-	-	5.42	-
Follow-up Hdwy	-	-	2.218	-	3.518	3.318
Pot Cap-1 Maneuver	-	-	1550	-	818	1013
Stage 1	-	-	-	-	969	-
Stage 2	-	-	-	-	907	-
Platoon blocked, %	-	-	-	-	-	-
Mov Cap-1 Maneuver	-	-	1550	-	810	1013
Mov Cap-2 Maneuver	-	-	-	-	810	-
Stage 1	-	-	-	-	969	-
Stage 2	-	-	-	-	898	-
Approach	EB	WB	NB			
HCM Control Delay, s	0	1	9			
HCM LOS					A	
Minor Lane/Major Mvmt	NBLn1	EBT	EBR	WBL	WBT	
Capacity (veh/h)	946	-	-	1550	-	
HCM Lane V/C Ratio	0.037	-	-	0.009	-	
HCM Control Delay (s)	9	-	-	7.3	0	
HCM Lane LOS	A	-	-	A	A	
HCM 95th %tile Q(veh)	0.1	-	-	0	-	

# ATTACHMENT F – PARCEL INFORMATION

## 130-13-025A Commercial Parcel

This is a commercial parcel located at [3632 N BISHOP LN SCOTTSDALE 85251](#), and the current owner is NEXT GEN BISHOP LLC. It is located in the Matlock Place subdivision and MCR 3250. Its current year full cash value is \$580,300.

---

### Property Information

#### [3632 N BISHOP LN SCOTTSDALE 85251](#)

MCR #	<a href="#">3250</a>
Description:	MATLOCK PLACE N2 LOT 17 BLK 1 & ALL LOT 18 BLK 1
Lat/Long	<a href="#">33.49026000 -111.92723599</a>
Lot Size	9,625 sq ft.
Zoning	C-3
Lot #	17
High School District	SCOTTSDALE UNIFIED #48
Elementary School District	SCOTTSDALE UNIFIED SCHOOL DISTRICT
Local Jurisdiction	SCOTTSDALE
S/T/R	27 2N 4E
Market Area/Neighborhood	19/005
Subdivision (24 Parcels)	<a href="#">MATLOCK PLACE</a>

---

### Owner Information

#### [NEXT GEN BISHOP LLC](#)

Mailing Address	3335 E INDIAN SCHOOL RD STE 100, PHOENIX, AZ 85018-5026
Deed Number	<a href="#">180569552</a>
Last Deed Date	07/27/2018
Sale Date	n/a
Sale Price	n/a

---

## Valuation Information

We provide valuation information for the past 5 years. For mobile display, we only show 1 year of valuation information. Should you need more data, please look at our [data sales](#).

**The Valuation Information displayed below may not reflect the taxable value used on the tax bill due to any special valuation relief program. [CLICK HERE TO PAY YOUR TAXES OR VIEW YOUR TAX BILL](#)**

Tax Year	2019	2018	2017	2016	2015
Full Cash Value	\$580,300	\$563,800	\$560,100	\$485,600	\$454,700
Limited Property Value	\$414,792	\$395,040	\$376,229	\$358,313	\$341,250
Legal Class	1	1	1	1	1
Description	COMMERCIAL / OTHER R/P	COMMERCIAL / OTHER R/P	COMMERCIAL / OTHER R/P	COMMERCIAL / OTHER R/P	COMMERCIAL / OTHER R/P
Assessment Ratio	18%	18%	18%	18%	18.5%
Assessed FCV	n/a	n/a	n/a	n/a	n/a
Assessed LPV	\$74,663	\$71,107	\$67,721	\$64,496	\$63,131
Property Use Code	1120	1120	1120	1120	1120
PU Description	Retail	Retail	Retail	Retail	Retail
Tax Area Code	481400	481400	481400	481400	481400
Valuation Source	Notice	Notice	Notice	Notice	Notice

## Additional Property Information

Additional commercial property data.

Description	Imp #	Occupancy Rank	CCI	Age	Sq Ft.
Retail Store	000101 353	2	C	40	1,666
Site Improvements	000201 163	2	D	40	1

### Building Sketches

Sketches that illustrate the external dimensions of a property.

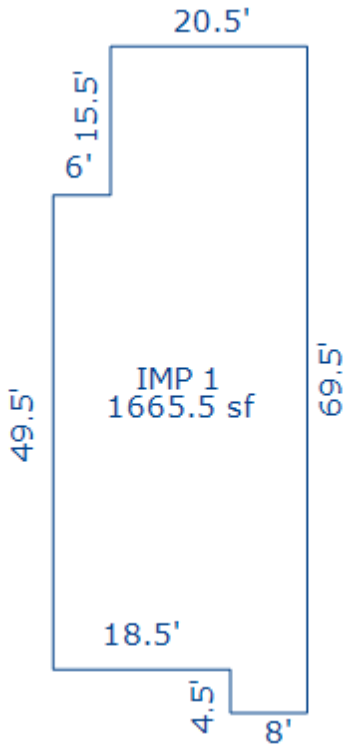

---

### Similar Parcels

Parcels that are similar to this one (known as the reference parcel) are displayed below.

**APN Address Sale Info FCV Size Livable Sq Ft Year Built Pool Foreclosed**

No similar parcels found.

---

## 130-13-027 Commercial Parcel

This is a commercial parcel located at [3638 N BISHOP LN SCOTTSDALE 85251](#), and the current owner is NEXT GEN OLD TOWN LLC. It is located in the Matlock Place subdivision and MCR 3250. Its current year full cash value is \$310,400.

---

### Property Information

#### [3638 N BISHOP LN SCOTTSDALE 85251](#)

MCR #	<a href="#">3250</a>
Description:	MATLOCK PLACE
Lat/Long	<a href="#">33.49042200 -111.92723599</a>
Lot Size	6,417 sq ft.
Zoning	C-3
Lot #	19
High School District	SCOTTSDALE UNIFIED #48
Elementary School District	SCOTTSDALE UNIFIED SCHOOL DISTRICT
Local Jurisdiction	SCOTTSDALE
S/T/R	27 2N 4E
Market Area/Neighborhood	19/005
Subdivision (24 Parcels)	<a href="#">MATLOCK PLACE</a>

---

### Owner Information

#### [NEXT GEN OLD TOWN LLC](#)

Mailing Address	3335 E INDIAN SCHOOL RD SUITE 100, PHOENIX, AZ 85018
Deed Number	<a href="#">180012748</a>
Last Deed Date	01/05/2018
Sale Date	n/a
Sale Price	n/a

---

## Valuation Information

We provide valuation information for the past 5 years. For mobile display, we only show 1 year of valuation information. Should you need more data, please look at our [data sales](#).

**The Valuation Information displayed below may not reflect the taxable value used on the tax bill due to any special valuation relief program. [CLICK HERE TO PAY YOUR TAXES OR VIEW YOUR TAX BILL](#)**

Tax Year	2019	2018	2017	2016	2015
Full Cash Value	\$310,400	\$288,800	\$288,800	\$244,800	\$241,900
Limited Property Value	\$283,387	\$269,892	\$257,040	\$244,800	\$241,900
Legal Class	1	1	1	1	1
Description	COMMERCIAL / OTHER R/P	COMMERCIAL / OTHER R/P	COMMERCIAL / OTHER R/P	COMMERCIAL / OTHER R/P	COMMERCIAL / OTHER R/P
Assessment Ratio	18%	18%	18%	18%	18.5%
Assessed FCV	n/a	n/a	n/a	n/a	n/a
Assessed LPV	\$51,010	\$48,581	\$46,267	\$44,064	\$44,752
Property Use Code	1074	1074	1074	1074	1074
PU Description	Associated Commercial	Associated Commercial	Associated Commercial	Associated Commercial	Associated Commercial
Tax Area Code	481400	481400	481400	481400	481400
Valuation Source	Notice	Notice	Notice	Notice	Decision

## Similar Parcels

Parcels that are similar to this one (known as the reference parcel) are displayed below.

**APN Address Sale Info FCV Size Livable Sq Ft Year Built Pool Foreclosed**

No similar parcels found.

## 130-13-028 Commercial Parcel

This is a commercial parcel and the current owner is NEXT GEN OLD TOWN LLC. It is located in the Matlock Place subdivision and MCR 3250. Its current year full cash value is \$155,100.

---

### Property Information

MCR #	<a href="#">3250</a>
Description:	MATLOCK PLACE S2 LOT 20 BLK 1
Lat/Long	
Lot Size	3,208 sq ft.
Zoning	C-3
Lot #	20
High School District	SCOTTSDALE UNIFIED #48
Elementary School District	SCOTTSDALE UNIFIED SCHOOL DISTRICT
Local Jurisdiction	SCOTTSDALE
S/T/R	27 2N 4E
Market Area/Neighborhood	19/005
Subdivision (24 Parcels)	<a href="#">MATLOCK PLACE</a>

---

### Owner Information

#### [NEXT GEN OLD TOWN LLC](#)

Mailing Address	3335 E INDIAN SCHOOL RD SUITE 100, PHOENIX, AZ 85018
Deed Number	<a href="#">180012748</a>
Last Deed Date	01/05/2018
Sale Date	n/a
Sale Price	n/a

---

## Valuation Information

We provide valuation information for the past 5 years. For mobile display, we only show 1 year of valuation information. Should you need more data, please look at our [data sales](#).

**The Valuation Information displayed below may not reflect the taxable value used on the tax bill due to any special valuation relief program. [CLICK HERE TO PAY YOUR TAXES OR VIEW YOUR TAX BILL](#)**

Tax Year	2019	2018	2017	2016	2015
Full Cash Value	\$155,100	\$144,400	\$144,400	\$122,400	\$120,900
Limited Property Value	\$141,693	\$134,946	\$128,520	\$122,400	\$120,900
Legal Class	1	1	1	1	1
Description	COMMERCIAL / OTHER R/P	COMMERCIAL / OTHER R/P	COMMERCIAL / OTHER R/P	COMMERCIAL / OTHER R/P	COMMERCIAL / OTHER R/P
Assessment Ratio	18%	18%	18%	18%	18.5%
Assessed FCV	n/a	n/a	n/a	n/a	n/a
Assessed LPV	\$25,505	\$24,290	\$23,134	\$22,032	\$22,367
Property Use Code	1074	1074	1074	1074	1074
PU Description	Associated Commercial	Associated Commercial	Associated Commercial	Associated Commercial	Associated Commercial
Tax Area Code	481400	481400	481400	481400	481400
Valuation Source	Notice	Notice	Notice	Notice	Decision

## Similar Parcels

Parcels that are similar to this one (known as the reference parcel) are displayed below.

**APN Address Sale Info FCV Size Livable Sq Ft Year Built Pool Foreclosed**

No similar parcels found.

## 130-13-029 Commercial Parcel

This is a commercial parcel located at [3702 N BISHOP LN SCOTTSDALE 85251](#), and the current owner is NEXT GEN OLD TOWN LLC. It is located in the Matlock Place subdivision and MCR 3250. Its current year full cash value is \$465,600.

---

### Property Information

#### [3702 N BISHOP LN SCOTTSDALE 85251](#)

MCR #	<a href="#">3250</a>
Description:	MATLOCK PLACE ALL 21 & N2 LOT 20 BLK 1
Lat/Long	<a href="#">33.49065697 -111.92723493</a>
Lot Size	9,625 sq ft.
Zoning	C-3
Lot #	21
High School District	SCOTTSDALE UNIFIED #48
Elementary School District	SCOTTSDALE UNIFIED SCHOOL DISTRICT
Local Jurisdiction	SCOTTSDALE
S/T/R	27 2N 4E
Market Area/Neighborhood	19/005
Subdivision (24 Parcels)	<a href="#">MATLOCK PLACE</a>

---

### Owner Information

#### [NEXT GEN OLD TOWN LLC](#)

Mailing Address	3335 E INDIAN SCHOOL RD SUITE 100, PHOENIX, AZ 85018
Deed Number	<a href="#">180012748</a>
Last Deed Date	01/05/2018
Sale Date	n/a
Sale Price	n/a

---

## Valuation Information

We provide valuation information for the past 5 years. For mobile display, we only show 1 year of valuation information. Should you need more data, please look at our [data sales](#).

**The Valuation Information displayed below may not reflect the taxable value used on the tax bill due to any special valuation relief program. [CLICK HERE TO PAY YOUR TAXES OR VIEW YOUR TAX BILL](#)**

Tax Year	2019	2018	2017	2016	2015
Full Cash Value	\$465,600	\$433,300	\$433,300	\$367,200	\$362,900
Limited Property Value	\$425,080	\$404,838	\$385,560	\$367,200	\$362,880
Legal Class	1	1	1	1	1
Description	COMMERCIAL / OTHER R/P	COMMERCIAL / OTHER R/P	COMMERCIAL / OTHER R/P	COMMERCIAL / OTHER R/P	COMMERCIAL / OTHER R/P
Assessment Ratio	18%	18%	18%	18%	18.5%
Assessed FCV	n/a	n/a	n/a	n/a	n/a
Assessed LPV	\$76,514	\$72,871	\$69,401	\$66,096	\$67,133
Property Use Code	1074	1074	1074	1074	1074
PU Description	Associated Commercial	Associated Commercial	Associated Commercial	Associated Commercial	Associated Commercial
Tax Area Code	481400	481400	481400	481400	481400
Valuation Source	Notice	Notice	Notice	Notice	Decision

## Similar Parcels

Parcels that are similar to this one (known as the reference parcel) are displayed below.

**APN Address Sale Info FCV Size Livable Sq Ft Year Built Pool Foreclosed**

No similar parcels found.

## 130-13-030A Commercial Parcel

This is a commercial parcel located at [7125 E 2ND ST SCOTTSDALE 85251](#), and the current owner is NEXT GEN OLD TOWN LLC. It is located in the Matlock Place subdivision and MCR 3250. Its current year full cash value is \$1,657,000.

---

### Property Information

#### [7125 E 2ND ST SCOTTSDALE 85251](#)

MCR #	<a href="#">3250</a>
Description:	MATLOCK LOTS 22 & 23 & 24 BLK 1
Lat/Long	<a href="#">33.49125250 -111.92748177</a>
Lot Size	20,455 sq ft.
Zoning	C-3
Lot #	22
High School District	SCOTTSDALE UNIFIED #48
Elementary School District	SCOTTSDALE UNIFIED SCHOOL DISTRICT
Local Jurisdiction	SCOTTSDALE
S/T/R	27 2N 4E
Market Area/Neighborhood	19/005
Subdivision (24 Parcels)	<a href="#">MATLOCK PLACE</a>

---

### Owner Information

#### [NEXT GEN OLD TOWN LLC](#)

Mailing Address	3335 E INDIAN SCHOOL RD SUITE 100, PHOENIX, AZ 85018
Deed Number	<a href="#">180012748</a>
Last Deed Date	01/05/2018
Sale Date	n/a
Sale Price	n/a

---

## Valuation Information

We provide valuation information for the past 5 years. For mobile display, we only show 1 year of valuation information. Should you need more data, please look at our [data sales](#).

**The Valuation Information displayed below may not reflect the taxable value used on the tax bill due to any special valuation relief program. [CLICK HERE TO PAY YOUR TAXES OR VIEW YOUR TAX BILL](#)**

Tax Year	2019	2018	2017	2016	2015
Full Cash Value	\$1,657,000	\$1,586,900	\$1,670,800	\$1,471,700	\$1,375,600
Limited Property Value	\$1,588,205	\$1,512,576	\$1,440,549	\$1,371,951	\$1,306,620
Legal Class	1	1	1	1	1
Description	COMMERCIAL / OTHER R/P	COMMERCIAL / OTHER R/P	COMMERCIAL / OTHER R/P	COMMERCIAL / OTHER R/P	COMMERCIAL / OTHER R/P
Assessment Ratio	18%	18%	18%	18%	18.5%
Assessed FCV	n/a	n/a	n/a	n/a	n/a
Assessed LPV	\$285,877	\$272,264	\$259,299	\$246,951	\$241,725
Property Use Code	2010	2010	2932	2932	2932
PU Description	Restaurant	Restaurant	Private School	Private School	Private School
Tax Area Code	481400	481400	481400	481400	481400
Valuation Source	Notice	Notice	Notice	Notice	Decision

## Additional Property Information

Additional commercial property data.

Description	Imp #	Occupancy	Rank	CCI	Age	Sq Ft.
Restaurant	000101	350	2.5	C	27	5,120
Site Improvements	000201	163	2	D	27	1



# ATTACHMENT G – TRIP GENERATION





Existing Zoning

820 Shopping Center																						
Land Use	ITE Code	Qty	Unit	Weekday			AM Peak Hour			PM Peak Hour			Weekday			AM Peak Hour			PM Peak Hour			
				Rate	% In	% Out	Rate	% In	% Out	Rate	% In	% Out	Total	In	Out	Total	In	Out	Total	In	Out	
Shopping Center	820	39.5	1000 SF GLA	37.75	50%	50%	0.94	62%	38%	3.81	48%	52%	1,490	745	745	37	23	14	150	72	78	Average
Shopping Center	820	39.5	1000 SF GLA	7.42	50%	50%	0.18	62%	38%	0.74	48%	52%	293	147	146	7	5	2	29	14	15	Minimum
Shopping Center	820	39.5	1000 SF GLA	207.98	50%	50%	23.74	62%	38%	18.69	48%	52%	8,208	4,104	4,104	937	581	356	738	355	383	Maximum
Land Use	ITE Code	Qty	Unit	Weekday			AM Peak Hour			PM Peak Hour			Weekday			AM Peak Hour			PM Peak Hour			
				Equation	% In	% Out	Equation	% In	% Out	Equation	% In	% Out	Total	In	Out	Total	In	Out	Total	In	Out	
Shopping Center	820	39.5	1000 SF GLA	$\ln(T)=0.68\ln(X)+5.57$	50%	50%	$T=0.50(X)+151.78$	62%	38%	$\ln(T)=0.74\ln(X)+2.89$	48%	52%	3,195	1,598	1,597	172	107	65	273	132	141	Equation
Shopping Center				Standard Deviation	1.55			0.2			0.18											
Shopping Center				Number of Studies	29			34			47											
Shopping Center				Average Size	285			451			400											



ATTACHMENT H – CITY OF SCOTTSDALES  
DESIGN STANDARDS & POLICIES MANUAL,  
FIGURE 5-1.2

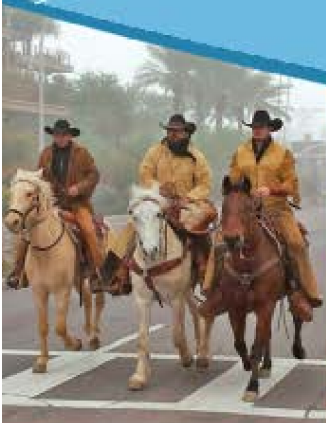
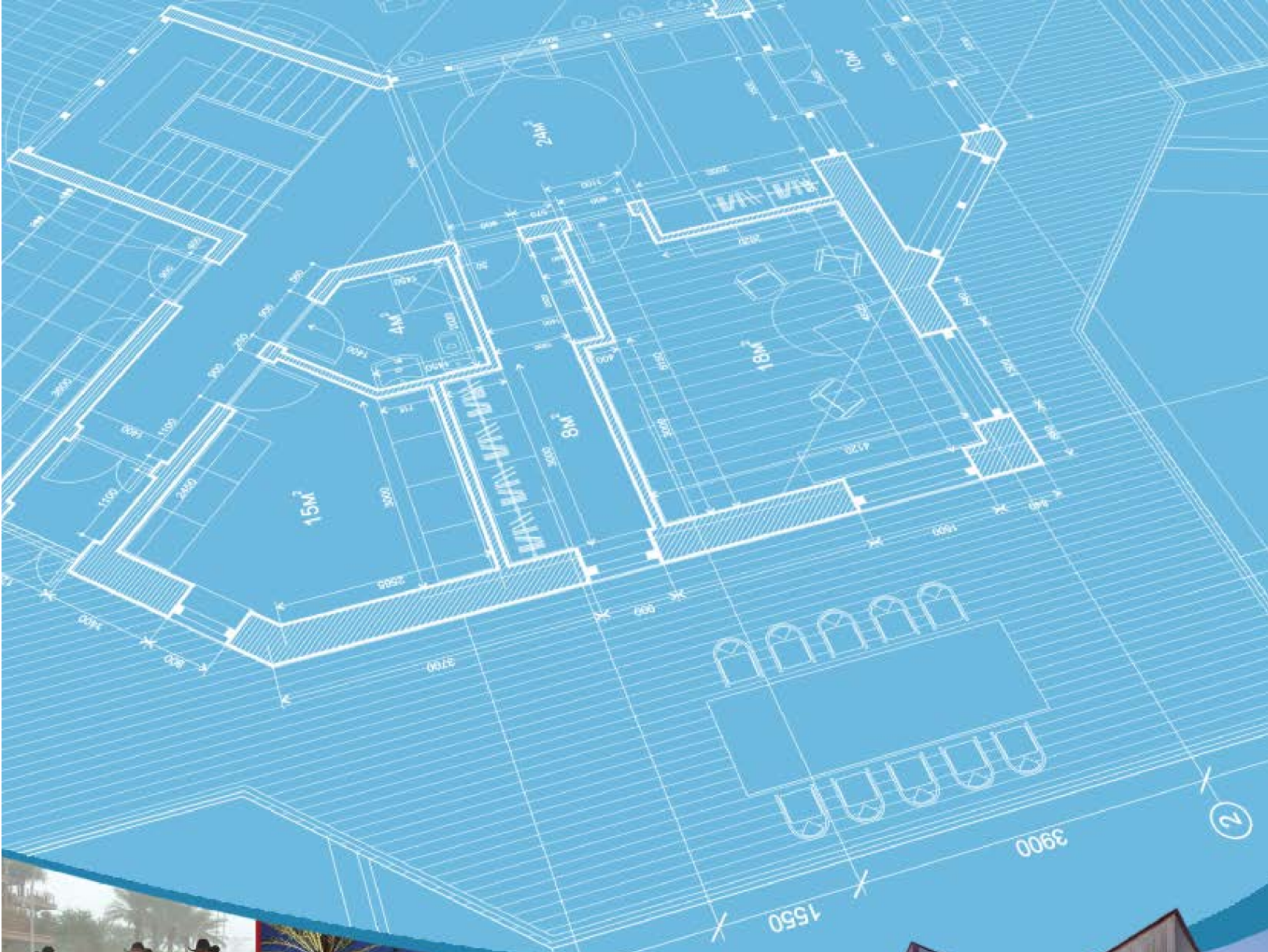

  
CITY OF  
**SCOTTSDALE**

# DESIGN STANDARDS & POLICIES MANUAL

TYPE OF CONDITION	PARAMETER	SYMBOL	DEFAULT
Geometric Conditions	Area Type	Central Business District (CBD), Other	No default
	Number of Lanes	N	No default
	Average Lane Width, ft.	W	No default
	Grade, %	%G	0%
	Existence of Exclusive Left Turn (LT) or Right Turn (RT) Lanes	None	No default
	Parking Conditions	Yes, No	No parking
	Traffic Conditions	Volumes by Movement, vph	V
Ideal Saturation Flow Rate by Mov't, pcphgpl		S <sub>o</sub>	2,000 pcphgpl (through lanes) 1,800 pcphgpl (turn lanes)
Peak Hour Factor		PHF	0.92
Percent Heavy Vehicles		%HV	2%
Conflicting Pedestrian Flow Rate, peds/hr		PEDS	None: 0 peds/hr Low: 50 peds/hr Mod: 200 peds/hr High: 400 peds/hr
Local Buses Stopping in Intersection		North Bound (NB)	0/hr
Parking Activity, pkg maneuvers/hr		N <sub>m</sub>	20/hr (pkg exists)
Arrival Type (1-6)		AT	3 if isolated 4 if coordinated
Proportion of Vehicles Arriving on Green		P	
Signalization Condition	Cycle Length, sec	C	60-120 seconds
	Green Time, sec	G	No default
	Yellow Change Interval	Y	3.0 seconds
	All-Red Clearance Interval	AR	1.0 second
	Actuated or Pre-Timed Operation	A or P	Actuated
	Pedestrian Push-Button?	Yes, No	Yes
	Minimum Pedestrian Green	G <sub>p</sub>	No default
	Phase Plan	None	No default



















FIGURE 5-1.2 LEVEL OF SERVICE DEFAULT DATA

One of the most critical traffic characteristics that must be quantified to complete an operational analysis is the quality of the progression. The arrival

# ATTACHMENT I – YEAR 2025 NO BUILD CAPACITY ANALYSIS

Some Synchro outputs under Attachment I are taken directly from the Museum Square Traffic Impact & Mitigation Analysis, dated August 10, 2018. For organizational purposes, the intersections for the Museum Square Traffic Impact & Mitigation Analysis have been changed to:

<b>Intersection</b>	<b>August 10, 2018 TI&amp;MA Intersection Number</b>	<b>2nd Street and Bishop TI&amp;MA Intersection Number</b>
Goldwater Boulevard and 2nd Street	12	1
Marshall Way and 2nd Street	16	2
Scottsdale Road and 2nd Street	17	3
Goldwater Boulevard and 70th Street	18	4
Goldwater Boulevard and Marshall Way	20	5
Goldwater Boulevard and Scottsdale Road	21	7

												
Movement	EBL	EBT	EBR	WBL	WBT	WBR	NBL	NBT	NBR	SBL	SBT	SBR
Lane Configurations												
Traffic Volume (veh/h)	18	33	15	10	9	37	11	463	15	59	504	18
Future Volume (veh/h)	18	33	15	10	9	37	11	463	15	59	504	18
Number	3	8	18	7	4	14	1	6	16	5	2	12
Initial Q (Qb), veh	0	0	0	0	0	0	0	0	0	0	0	0
Ped-Bike Adj(A_pbT)	0.79		0.75	0.79		0.75	0.94		0.87	0.97		0.86
Parking Bus, Adj	1.00	1.00	1.00	1.00	1.00	1.00	1.00	1.00	1.00	1.00	1.00	1.00
Adj Sat Flow, veh/h/ln	1900	1863	1900	1900	1863	1900	1863	1863	1900	1863	1863	1900
Adj Flow Rate, veh/h	20	36	16	11	10	40	12	503	16	64	548	20
Adj No. of Lanes	0	1	0	0	1	0	1	2	0	1	3	0
Peak Hour Factor	0.92	0.92	0.92	0.92	0.92	0.92	0.92	0.92	0.92	0.92	0.92	0.92
Percent Heavy Veh, %	2	2	2	2	2	2	2	2	2	2	2	2
Cap, veh/h	115	194	77	73	68	201	595	2352	75	590	3379	122
Arrive On Green	0.24	0.24	0.24	0.24	0.24	0.24	0.68	0.68	0.68	1.00	1.00	1.00
Sat Flow, veh/h	318	802	320	157	281	834	793	3483	111	855	5005	181
Grp Volume(v), veh/h	72	0	0	61	0	0	12	255	264	64	370	198
Grp Sat Flow(s),veh/h/ln	1440	0	0	1272	0	0	793	1770	1824	855	1695	1796
Q Serve(g_s), s	0.0	0.0	0.0	0.0	0.0	0.0	0.6	6.6	6.6	0.8	0.0	0.0
Cycle Q Clear(g_c), s	4.1	0.0	0.0	4.3	0.0	0.0	0.6	6.6	6.6	7.4	0.0	0.0
Prop In Lane	0.28		0.22	0.18		0.66	1.00		0.06	1.00		0.10
Lane Grp Cap(c), veh/h	386	0	0	343	0	0	595	1195	1232	590	2289	1212
V/C Ratio(X)	0.19	0.00	0.00	0.18	0.00	0.00	0.02	0.21	0.21	0.11	0.16	0.16
Avail Cap(c_a), veh/h	528	0	0	468	0	0	595	1195	1232	590	2289	1212
HCM Platoon Ratio	1.00	1.00	1.00	1.00	1.00	1.00	1.00	1.00	1.00	2.00	2.00	2.00
Upstream Filter(I)	1.00	0.00	0.00	1.00	0.00	0.00	1.00	1.00	1.00	1.00	1.00	1.00
Uniform Delay (d), s/veh	36.1	0.0	0.0	36.1	0.0	0.0	6.4	7.4	7.4	0.3	0.0	0.0
Incr Delay (d2), s/veh	0.1	0.0	0.0	0.1	0.0	0.0	0.1	0.4	0.4	0.4	0.2	0.3
Initial Q Delay(d3),s/veh	0.0	0.0	0.0	0.0	0.0	0.0	0.0	0.0	0.0	0.0	0.0	0.0
%ile BackOfQ(50%),veh/ln	1.9	0.0	0.0	1.6	0.0	0.0	0.1	3.3	3.4	0.2	0.0	0.1
LnGrp Delay(d),s/veh	36.2	0.0	0.0	36.2	0.0	0.0	6.5	7.8	7.8	0.7	0.2	0.3
LnGrp LOS	D			D			A	A	A	A	A	A
Approach Vol, veh/h		72			61			531			632	
Approach Delay, s/veh		36.2			36.2			7.8			0.2	
Approach LOS		D			D			A			A	
Timer	1	2	3	4	5	6	7	8				
Assigned Phs		2		4		6		8				
Phs Duration (G+Y+Rc), s		86.2		33.8		86.2		33.8				
Change Period (Y+Rc), s		* 5.2		* 4.8		* 5.2		* 4.8				
Max Green Setting (Gmax), s		* 69		* 41		* 69		* 41				
Max Q Clear Time (g_c+I1), s		9.4		6.3		8.6		6.1				
Green Ext Time (p_c), s		0.2		0.3		0.2		0.3				
<b>Intersection Summary</b>												
HCM 2010 Ctrl Delay				7.0								
HCM 2010 LOS				A								
<b>Notes</b>												

12: Goldwater Boulevard & 2nd Street

02/22/2019

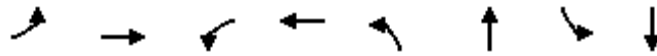

Lane Group	EBL	EBT	WBL	WBT	NBL	NBT	SBL	SBT
Lane Configurations		↕↕		↕↕	↖	↕↕	↖	↕↕↕
Traffic Volume (vph)	18	33	10	9	11	463	59	504
Future Volume (vph)	18	33	10	9	11	463	59	504
Turn Type	Perm	NA	Perm	NA	Perm	NA	Perm	NA
Protected Phases		8		4		6		2
Permitted Phases	8		4		6		2	
Detector Phase	8	8	4	4	6	6	2	2
Switch Phase								
Minimum Initial (s)	7.0	7.0	7.0	7.0	10.0	10.0	10.0	10.0
Minimum Split (s)	33.8	33.8	33.8	33.8	23.2	23.2	24.2	24.2
Total Split (s)	46.0	46.0	46.0	46.0	74.0	74.0	74.0	74.0
Total Split (%)	38.3%	38.3%	38.3%	38.3%	61.7%	61.7%	61.7%	61.7%
Yellow Time (s)	3.3	3.3	3.3	3.3	4.0	4.0	4.0	4.0
All-Red Time (s)	1.5	1.5	1.5	1.5	1.2	1.2	1.2	1.2
Lost Time Adjust (s)		0.0		0.0	0.0	0.0	0.0	0.0
Total Lost Time (s)		4.8		4.8	5.2	5.2	5.2	5.2
Lead/Lag								
Lead-Lag Optimize?								
Recall Mode	Ped	Ped	None	None	C-Min	C-Min	C-Max	C-Max
Act Effct Green (s)		29.0		29.0	81.0	81.0	81.0	81.0
Actuated g/C Ratio		0.24		0.24	0.68	0.68	0.68	0.68
v/c Ratio		0.20		0.18	0.03	0.22	0.15	0.17
Control Delay		31.4		17.7	3.9	4.7	14.4	12.7
Queue Delay		0.0		0.0	0.0	0.0	0.0	0.0
Total Delay		31.4		17.7	3.9	4.7	14.4	12.7
LOS		C		B	A	A	B	B
Approach Delay		31.4		17.7		4.7		12.9
Approach LOS		C		B		A		B

Intersection Summary

Cycle Length: 120  
 Actuated Cycle Length: 120  
 Offset: 0 (0%), Referenced to phase 2:SBTL and 6:NBTL, Start of Green  
 Natural Cycle: 60  
 Control Type: Actuated-Coordinated  
 Maximum v/c Ratio: 0.22  
 Intersection Signal Delay: 10.8  
 Intersection Capacity Utilization 61.0%  
 Analysis Period (min) 15

Intersection LOS: B  
 ICU Level of Service B

Splits and Phases: 12: Goldwater Boulevard & 2nd Street

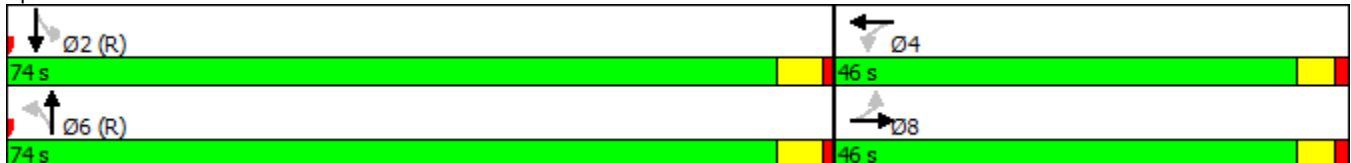

**Intersection**

Int Delay, s/veh 6.1

Movement	EBL	EBT	EBR	WBL	WBT	WBR	NBL	NBT	NBR	SBL	SBT	SBR
Lane Configurations		↕			↕		↕	↕		↕	↕	↕
Traffic Vol, veh/h	18	33	15	10	9	37	11	463	15	59	504	18
Future Vol, veh/h	18	33	15	10	9	37	11	463	15	59	504	18
Conflicting Peds, #/hr	200	0	200	200	0	200	200	0	200	200	0	200
Sign Control	Stop	Stop	Stop	Stop	Stop	Stop	Free	Free	Free	Free	Free	Free
RT Channelized	-	-	None	-	-	None	-	-	None	-	-	None
Storage Length	-	-	-	-	-	-	130	-	-	85	-	-
Veh in Median Storage, #	-	0	-	-	0	-	-	0	-	-	0	-
Grade, %	-	0	-	-	0	-	-	0	-	-	0	-
Peak Hour Factor	92	92	92	92	92	92	92	92	92	92	92	92
Heavy Vehicles, %	2	2	2	2	2	2	2	2	2	2	2	2
Mvmt Flow	20	36	16	11	10	40	12	503	16	64	548	20

Major/Minor	Minor2		Minor1		Major1		Major2					
Conflicting Flow All	1366	1629	684	1300	1631	660	767	0	0	720	0	0
Stage 1	886	886	-	735	735	-	-	-	-	-	-	-
Stage 2	480	743	-	565	896	-	-	-	-	-	-	-
Critical Hdwy	6.99	6.54	7.14	6.99	6.54	6.94	5.34	-	-	4.14	-	-
Critical Hdwy Stg 1	7.34	5.54	-	6.54	5.54	-	-	-	-	-	-	-
Critical Hdwy Stg 2	6.54	5.54	-	6.74	5.54	-	-	-	-	-	-	-
Follow-up Hdwy	3.67	4.02	3.92	3.67	4.02	3.32	3.12	-	-	2.22	-	-
Pot Cap-1 Maneuver	222	156	655	248	156	406	786	-	-	877	-	-
Stage 1	482	540	-	367	424	-	-	-	-	-	-	-
Stage 2	519	420	-	852	534	-	-	-	-	-	-	-
Platoon blocked, %	1	1	1	1	1	1	-	-	-	-	-	-
Mov Cap-1 Maneuver	112	97	455	109	97	282	655	-	-	731	-	-
Mov Cap-2 Maneuver	112	97	-	109	97	-	-	-	-	-	-	-
Stage 1	395	411	-	300	347	-	-	-	-	-	-	-
Stage 2	354	344	-	570	406	-	-	-	-	-	-	-

Approach	EB		WB		NB		SB	
HCM Control Delay, s	67.9		35.6		0.2		1.1	
HCM LOS	F		E					

Minor Lane/Major Mvmt	NBL	NBT	NBR	EBLn1WBLn1	SBL	SBT	SBR
Capacity (veh/h)	655	-	-	124	177	731	-
HCM Lane V/C Ratio	0.018	-	-	0.579	0.344	0.088	-
HCM Control Delay (s)	10.6	-	-	67.9	35.6	10.4	-
HCM Lane LOS	B	-	-	F	E	B	-
HCM 95th %tile Q(veh)	0.1	-	-	2.9	1.4	0.3	-

Intersection	
Intersection Delay, s/veh	7.5
Intersection LOS	A

Movement	EBL	EBT	EBR	WBL	WBT	WBR	NBL	NBT	NBR	SBL	SBT	SBR
Lane Configurations		↕			↕			↕			↕	
Traffic Vol, veh/h	11	67	22	2	32	2	22	12	6	2	12	10
Future Vol, veh/h	11	67	22	2	32	2	22	12	6	2	12	10
Peak Hour Factor	0.92	0.92	0.92	0.92	0.92	0.92	0.92	0.92	0.92	0.92	0.92	0.92
Heavy Vehicles, %	2	2	2	2	2	2	2	2	2	2	2	2
Mvmt Flow	12	73	24	2	35	2	24	13	7	2	13	11
Number of Lanes	0	1	0	0	1	0	0	1	0	0	1	0

Approach	EB	WB	NB	SB
Opposing Approach	WB	EB	SB	NB
Opposing Lanes	1	1	1	1
Conflicting Approach Left	SB	NB	EB	WB
Conflicting Lanes Left	1	1	1	1
Conflicting Approach Right	NB	SB	WB	EB
Conflicting Lanes Right	1	1	1	1
HCM Control Delay	7.6	7.4	7.5	7.2
HCM LOS	A	A	A	A

Lane	NBLn1	EBLn1	WBLn1	SBLn1
Vol Left, %	55%	11%	6%	8%
Vol Thru, %	30%	67%	89%	50%
Vol Right, %	15%	22%	6%	42%
Sign Control	Stop	Stop	Stop	Stop
Traffic Vol by Lane	40	100	36	24
LT Vol	22	11	2	2
Through Vol	12	67	32	12
RT Vol	6	22	2	10
Lane Flow Rate	43	109	39	26
Geometry Grp	1	1	1	1
Degree of Util (X)	0.051	0.12	0.045	0.029
Departure Headway (Hd)	4.231	3.975	4.116	3.991
Convergence, Y/N	Yes	Yes	Yes	Yes
Cap	838	898	864	886
Service Time	2.3	2.019	2.172	2.066
HCM Lane V/C Ratio	0.051	0.121	0.045	0.029
HCM Control Delay	7.5	7.6	7.4	7.2
HCM Lane LOS	A	A	A	A
HCM 95th-tile Q	0.2	0.4	0.1	0.1

Movement	EBL	EBT	EBR	WBL	WBT	WBR	NBL	NBT	NBR	SBL	SBT	SBR
Lane Configurations												
Traffic Volume (veh/h)	24	32	10	3	13	18	12	355	35	20	297	36
Future Volume (veh/h)	24	32	10	3	13	18	12	355	35	20	297	36
Number	3	8	18	7	4	14	1	6	16	5	2	12
Initial Q (Qb), veh	0	0	0	0	0	0	0	0	0	0	0	0
Ped-Bike Adj(A_pbT)	0.81		0.79	0.81		0.79	0.89		0.82	0.92		0.82
Parking Bus, Adj	1.00	1.00	0.90	1.00	1.00	1.00	1.00	1.00	1.00	1.00	1.00	1.00
Adj Sat Flow, veh/h/ln	1863	1863	1863	1900	1863	1900	1863	1863	1900	1863	1863	1900
Adj Flow Rate, veh/h	26	35	11	3	14	20	13	386	38	22	323	39
Adj No. of Lanes	1	1	1	0	1	0	1	2	0	1	2	0
Peak Hour Factor	0.92	0.92	0.92	0.92	0.92	0.92	0.92	0.92	0.92	0.92	0.92	0.92
Percent Heavy Veh, %	2	2	2	2	2	2	2	2	2	2	2	2
Cap, veh/h	441	531	321	75	180	224	610	1730	168	541	1685	199
Arrive On Green	0.29	0.29	0.29	0.29	0.29	0.29	0.54	0.54	0.54	1.00	1.00	1.00
Sat Flow, veh/h	1103	1863	1125	36	631	785	902	3186	310	878	3103	367
Grp Volume(v), veh/h	26	35	11	37	0	0	13	212	212	22	181	181
Grp Sat Flow(s),veh/h/ln	1103	1863	1125	1453	0	0	902	1770	1726	878	1770	1700
Q Serve(g_s), s	0.0	0.8	0.4	0.0	0.0	0.0	0.4	3.7	3.8	0.2	0.0	0.0
Cycle Q Clear(g_c), s	0.8	0.8	0.4	1.1	0.0	0.0	0.4	3.7	3.8	4.0	0.0	0.0
Prop In Lane	1.00		1.00	0.08		0.54	1.00		0.18	1.00		0.22
Lane Grp Cap(c), veh/h	441	531	321	479	0	0	610	961	937	541	961	924
V/C Ratio(X)	0.06	0.07	0.03	0.08	0.00	0.00	0.02	0.22	0.23	0.04	0.19	0.20
Avail Cap(c_a), veh/h	527	677	409	589	0	0	610	961	937	541	961	924
HCM Platoon Ratio	1.00	1.00	1.00	1.00	1.00	1.00	1.00	1.00	1.00	2.00	2.00	2.00
Upstream Filter(I)	1.00	1.00	1.00	1.00	0.00	0.00	1.00	1.00	1.00	1.00	1.00	1.00
Uniform Delay (d), s/veh	15.6	15.6	15.5	15.7	0.0	0.0	6.4	7.1	7.1	0.2	0.0	0.0
Incr Delay (d2), s/veh	0.0	0.0	0.0	0.0	0.0	0.0	0.1	0.5	0.6	0.1	0.4	0.5
Initial Q Delay(d3),s/veh	0.0	0.0	0.0	0.0	0.0	0.0	0.0	0.0	0.0	0.0	0.0	0.0
%ile BackOfQ(50%),veh/ln	0.3	0.4	0.1	0.4	0.0	0.0	0.1	2.0	2.0	0.1	0.1	0.1
LnGrp Delay(d),s/veh	15.6	15.6	15.5	15.7	0.0	0.0	6.4	7.6	7.7	0.4	0.4	0.5
LnGrp LOS	B	B	B	B			A	A	A	A	A	A
Approach Vol, veh/h		72			37			437			384	
Approach Delay, s/veh		15.6			15.7			7.6			0.4	
Approach LOS		B			B			A			A	
Timer	1	2	3	4	5	6	7	8				
Assigned Phs		2		4		6		8				
Phs Duration (G+Y+Rc), s		37.7		22.3		37.7		22.3				
Change Period (Y+Rc), s		5.1		* 5.2		5.1		* 5.2				
Max Green Setting (Gmax), s		27.9		* 22		27.9		* 22				
Max Q Clear Time (g_c+I1), s		6.0		3.1		5.8		2.8				
Green Ext Time (p_c), s		0.3		0.2		0.3		0.2				
<b>Intersection Summary</b>												
HCM 2010 Ctrl Delay			5.6									
HCM 2010 LOS			A									
<b>Notes</b>												

17: Scottsdale Road & 2nd Street

02/22/2019

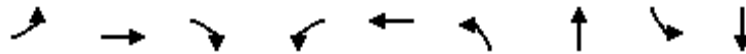

Lane Group	EBL	EBT	EBR	WBL	WBT	NBL	NBT	SBL	SBT
Lane Configurations	↘	↑	↗		↔	↘	↕	↘	↕
Traffic Volume (vph)	24	32	10	3	13	12	355	20	297
Future Volume (vph)	24	32	10	3	13	12	355	20	297
Turn Type	Perm	NA	Perm	Perm	NA	Perm	NA	Perm	NA
Protected Phases		8			4		6		2
Permitted Phases	8		8	4		6		2	
Detector Phase	8	8	8	4	4	6	6	2	2
Switch Phase									
Minimum Initial (s)	6.0	6.0	6.0	6.0	6.0	10.0	10.0	10.0	10.0
Minimum Split (s)	25.2	25.2	25.2	25.2	25.2	26.0	26.0	26.0	26.0
Total Split (s)	27.0	27.0	27.0	27.0	27.0	33.0	33.0	33.0	33.0
Total Split (%)	45.0%	45.0%	45.0%	45.0%	45.0%	55.0%	55.0%	55.0%	55.0%
Yellow Time (s)	3.0	3.0	3.0	3.0	3.0	3.0	3.0	3.0	3.0
All-Red Time (s)	2.2	2.2	2.2	2.2	2.2	2.1	2.1	2.1	2.1
Lost Time Adjust (s)	0.0	0.0	0.0		0.0	0.0	0.0	0.0	0.0
Total Lost Time (s)	5.2	5.2	5.2		5.2	5.1	5.1	5.1	5.1
Lead/Lag									
Lead-Lag Optimize?									
Recall Mode	None	None	None	None	None	C-Min	C-Min	C-Min	C-Min
Act Effct Green (s)	6.8	6.8	6.8		6.8	49.4	49.4	49.4	49.4
Actuated g/C Ratio	0.11	0.11	0.11		0.11	0.82	0.82	0.82	0.82
v/c Ratio	0.18	0.18	0.07		0.20	0.02	0.15	0.03	0.13
Control Delay	26.5	25.9	2.4		17.7	3.0	2.3	2.4	1.8
Queue Delay	0.0	0.0	0.0		0.0	0.0	0.0	0.0	0.0
Total Delay	26.5	25.9	2.4		17.7	3.0	2.3	2.4	1.8
LOS	C	C	A		B	A	A	A	A
Approach Delay		22.5			17.7		2.4		1.8
Approach LOS		C			B		A		A

Intersection Summary

Cycle Length: 60  
 Actuated Cycle Length: 60  
 Offset: 0 (0%), Referenced to phase 2:SBTL and 6:NBTL, Start of 1st Green  
 Natural Cycle: 55  
 Control Type: Actuated-Coordinated  
 Maximum v/c Ratio: 0.20  
 Intersection Signal Delay: 4.3  
 Intersection Capacity Utilization 62.9%  
 Analysis Period (min) 15

Intersection LOS: A  
 ICU Level of Service B

Splits and Phases: 17: Scottsdale Road & 2nd Street

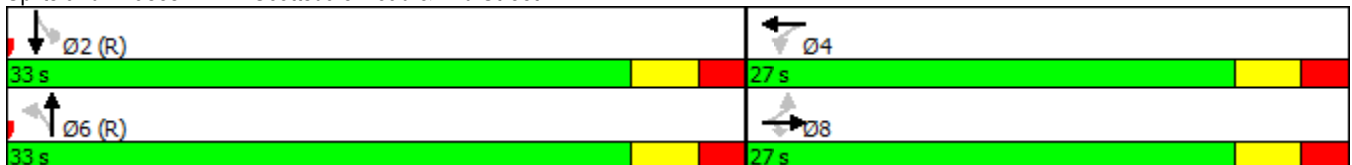

**Intersection**

Int Delay, s/veh 1.9

Movement	SET	SER	NWL	NWT	NEL	NER
Lane Configurations	↑↑↑		↘	↑↑	↘	↗
Traffic Vol, veh/h	413	67	11	389	83	25
Future Vol, veh/h	413	67	11	389	83	25
Conflicting Peds, #/hr	0	8	8	0	2	0
Sign Control	Free	Free	Free	Free	Stop	Stop
RT Channelized	-	None	-	None	-	None
Storage Length	-	-	70	-	0	0
Veh in Median Storage, #	0	-	-	0	0	-
Grade, %	0	-	-	0	0	-
Peak Hour Factor	92	92	92	92	92	92
Heavy Vehicles, %	2	2	2	2	2	2
Mvmt Flow	449	73	12	423	90	27

Major/Minor	Major1	Major2	Minor1
Conflicting Flow All	0	0	530
Stage 1	-	-	493
Stage 2	-	-	237
Critical Hdwy	-	5.34	6.29
Critical Hdwy Stg 1	-	-	6.64
Critical Hdwy Stg 2	-	-	5.84
Follow-up Hdwy	-	3.12	3.67
Pot Cap-1 Maneuver	-	656	388
Stage 1	-	-	503
Stage 2	-	-	752
Platoon blocked, %	-	-	-
Mov Cap-1 Maneuver	-	656	378
Mov Cap-2 Maneuver	-	-	378
Stage 1	-	-	500
Stage 2	-	-	737

Approach	SE	NW	NE
HCM Control Delay, s	0	0.3	16
HCM LOS			C

Minor Lane/Major Mvmt	NELn1	NELn2	NWL	NWT	SET	SER
Capacity (veh/h)	378	617	656	-	-	-
HCM Lane V/C Ratio	0.239	0.044	0.018	-	-	-
HCM Control Delay (s)	17.5	11.1	10.6	-	-	-
HCM Lane LOS	C	B	B	-	-	-
HCM 95th %tile Q(veh)	0.9	0.1	0.1	-	-	-

**Intersection**

Int Delay, s/veh 1.7

Movement	EBL	EBT	EBR	WBL	WBT	WBR	NBL	NBT	NBR	SBL	SBT	SBR
Lane Configurations	↖ ↑↑↑			↖ ↑↑				↔		↖ ↑		
Traffic Vol, veh/h	12	411	15	5	353	51	38	4	9	33	0	9
Future Vol, veh/h	12	411	15	5	353	51	38	4	9	33	0	9
Conflicting Peds, #/hr	0	0	3	3	0	0	5	0	2	2	0	5
Sign Control	Free	Free	Free	Free	Free	Free	Stop	Stop	Stop	Stop	Stop	Stop
RT Channelized	-	-	None	-	-	None	-	-	None	-	-	None
Storage Length	100	-	-	70	-	-	-	-	-	55	-	-
Veh in Median Storage, #	-	0	-	-	0	-	-	0	-	-	0	-
Grade, %	-	0	-	-	0	-	-	0	-	-	0	-
Peak Hour Factor	92	92	92	92	92	92	92	92	92	92	92	92
Heavy Vehicles, %	2	2	2	2	2	2	2	2	2	2	2	2
Mvmt Flow	13	447	16	5	384	55	41	4	10	36	0	10

Major/Minor	Major1	Major2	Minor1	Minor2
Conflicting Flow All	439	0	0	466
Stage 1	-	-	-	-
Stage 2	-	-	-	-
Critical Hdwy	4.14	-	-	5.34
Critical Hdwy Stg 1	-	-	-	-
Critical Hdwy Stg 2	-	-	-	-
Follow-up Hdwy	2.22	-	-	3.12
Pot Cap-1 Maneuver	1117	-	-	703
Stage 1	-	-	-	-
Stage 2	-	-	-	-
Platoon blocked, %	-	-	-	-
Mov Cap-1 Maneuver	1112	-	-	702
Mov Cap-2 Maneuver	-	-	-	-
Stage 1	-	-	-	-
Stage 2	-	-	-	-

Approach	EB	WB	NB	SB
HCM Control Delay, s	0.2	0.1	16.6	14.3
HCM LOS			C	B

Minor Lane/Major Mvmt	NBLn1	EBL	EBT	EBR	WBL	WBT	WBR	SBLn1	SBLn2
Capacity (veh/h)	365	1112	-	-	702	-	-	374	775
HCM Lane V/C Ratio	0.152	0.012	-	-	0.008	-	-	0.096	0.013
HCM Control Delay (s)	16.6	8.3	-	-	10.2	-	-	15.6	9.7
HCM Lane LOS	C	A	-	-	B	-	-	C	A
HCM 95th %tile Q(veh)	0.5	0	-	-	0	-	-	0.3	0

Movement	EBL	EBT	EBR	WBL	WBT	WBR	NBL	NBT	NBR	SBL	SBT	SBR
Lane Configurations												
Traffic Volume (veh/h)	12	6	9	259	15	9	46	399	20	34	420	25
Future Volume (veh/h)	12	6	9	259	15	9	46	399	20	34	420	25
Number	3	8	18	7	4	14	1	6	16	5	2	12
Initial Q (Qb), veh	0	0	0	0	0	0	0	0	0	0	0	0
Ped-Bike Adj(A_pbT)	1.00		0.94	1.00		1.00	1.00		1.00	1.00		1.00
Parking Bus, Adj	1.00	1.00	1.00	1.00	1.00	1.00	1.00	1.00	1.00	1.00	1.00	1.00
Adj Sat Flow, veh/h/ln	1863	1863	1900	1863	1863	1900	1863	1863	1900	1863	1863	1900
Adj Flow Rate, veh/h	13	7	10	303	0	0	50	434	22	37	457	27
Adj No. of Lanes	1	1	0	2	1	0	1	2	0	1	3	0
Peak Hour Factor	0.92	0.92	0.92	0.92	0.92	0.92	0.92	0.92	0.92	0.92	0.92	0.92
Percent Heavy Veh, %	2	2	2	2	2	2	2	2	2	2	2	2
Cap, veh/h	92	35	50	464	243	0	659	2373	120	663	3401	199
Arrive On Green	0.05	0.05	0.05	0.13	0.00	0.00	0.69	0.69	0.69	0.69	0.69	0.69
Sat Flow, veh/h	1774	670	957	3548	1863	0	907	3428	173	931	4914	288
Grp Volume(v), veh/h	13	0	17	303	0	0	50	224	232	37	314	170
Grp Sat Flow(s),veh/h/ln	1774	0	1626	1774	1863	0	907	1770	1832	931	1695	1811
Q Serve(g_s), s	0.8	0.0	1.2	9.7	0.0	0.0	2.4	5.3	5.4	1.8	3.8	3.8
Cycle Q Clear(g_c), s	0.8	0.0	1.2	9.7	0.0	0.0	6.2	5.3	5.4	7.1	3.8	3.8
Prop In Lane	1.00		0.59	1.00		0.00	1.00		0.09	1.00		0.16
Lane Grp Cap(c), veh/h	92	0	85	464	243	0	659	1225	1268	663	2347	1254
V/C Ratio(X)	0.14	0.00	0.20	0.65	0.00	0.00	0.08	0.18	0.18	0.06	0.13	0.14
Avail Cap(c_a), veh/h	223	0	205	1333	700	0	659	1225	1268	663	2347	1254
HCM Platoon Ratio	1.00	1.00	1.00	1.00	1.00	1.00	1.00	1.00	1.00	1.00	1.00	1.00
Upstream Filter(I)	1.00	0.00	1.00	1.00	0.00	0.00	1.00	1.00	1.00	1.00	1.00	1.00
Uniform Delay (d), s/veh	54.3	0.0	54.5	49.6	0.0	0.0	7.3	6.5	6.5	7.8	6.3	6.3
Incr Delay (d2), s/veh	0.3	0.0	0.4	0.6	0.0	0.0	0.2	0.3	0.3	0.2	0.1	0.2
Initial Q Delay(d3),s/veh	0.0	0.0	0.0	0.0	0.0	0.0	0.0	0.0	0.0	0.0	0.0	0.0
%ile BackOfQ(50%),veh/ln	0.4	0.0	0.5	4.8	0.0	0.0	0.6	2.7	2.8	0.5	1.8	2.0
LnGrp Delay(d),s/veh	54.6	0.0	54.9	50.2	0.0	0.0	7.5	6.8	6.8	7.9	6.4	6.5
LnGrp LOS	D		D	D			A	A	A	A	A	A
Approach Vol, veh/h		30			303			506			521	
Approach Delay, s/veh		54.8			50.2			6.9			6.5	
Approach LOS		D			D			A			A	
Timer	1	2	3	4	5	6	7	8				
Assigned Phs		2		4		6		8				
Phs Duration (G+Y+Rc), s		88.3		20.6		88.3		11.1				
Change Period (Y+Rc), s		* 5.2		* 4.9		* 5.2		4.9				
Max Green Setting (Gmax), s		* 45		* 45		* 45		15.1				
Max Q Clear Time (g_c+I1), s		9.1		11.7		8.2		3.2				
Green Ext Time (p_c), s		1.7		0.6		1.7		0.0				
<b>Intersection Summary</b>												
HCM 2010 Ctrl Delay			17.5									
HCM 2010 LOS			B									
<b>Notes</b>												

21: Goldwater Boulevard & Driveway/Scottsdale Road

02/22/2019

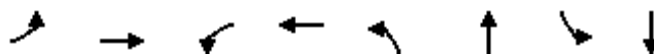

Lane Group	EBL	EBT	WBL	WBT	NBL	NBT	SBL	SBT
Lane Configurations								
Traffic Volume (vph)	12	6	259	15	46	399	34	420
Future Volume (vph)	12	6	259	15	46	399	34	420
Turn Type	Split	NA	Split	NA	Perm	NA	Perm	NA
Protected Phases	8	8	4	4		6		2
Permitted Phases					6		2	
Detector Phase	8	8	4	4	6	6	2	2
Switch Phase								
Minimum Initial (s)	7.0	7.0	7.0	7.0	10.0	10.0	10.0	10.0
Minimum Split (s)	13.0	13.0	13.0	13.0	16.0	16.0	16.0	16.0
Total Split (s)	20.0	20.0	50.0	50.0	50.0	50.0	50.0	50.0
Total Split (%)	16.7%	16.7%	41.7%	41.7%	41.7%	41.7%	41.7%	41.7%
Yellow Time (s)	3.3	3.3	3.3	3.3	4.0	4.0	4.0	4.0
All-Red Time (s)	1.6	1.6	1.6	1.6	1.2	1.2	1.2	1.2
Lost Time Adjust (s)	0.0	0.0	0.0	0.0	0.0	0.0	0.0	0.0
Total Lost Time (s)	4.9	4.9	4.9	4.9	5.2	5.2	5.2	5.2
Lead/Lag	Lead	Lead	Lag	Lag				
Lead-Lag Optimize?								
Recall Mode	None	None	None	None	C-Max	C-Max	C-Max	C-Max
Act Effct Green (s)	8.6	8.6	17.6	17.6	83.5	83.5	83.5	83.5
Actuated g/C Ratio	0.07	0.07	0.15	0.15	0.70	0.70	0.70	0.70
v/c Ratio	0.10	0.14	0.63	0.61	0.08	0.19	0.06	0.14
Control Delay	52.0	53.1	56.6	54.9	8.2	6.5	7.8	6.0
Queue Delay	0.0	0.0	0.0	0.0	0.0	0.0	0.0	0.0
Total Delay	52.0	53.1	56.6	54.9	8.2	6.5	7.8	6.0
LOS	D	D	E	D	A	A	A	A
Approach Delay		52.6		55.8		6.7		6.1
Approach LOS		D		E		A		A

Intersection Summary





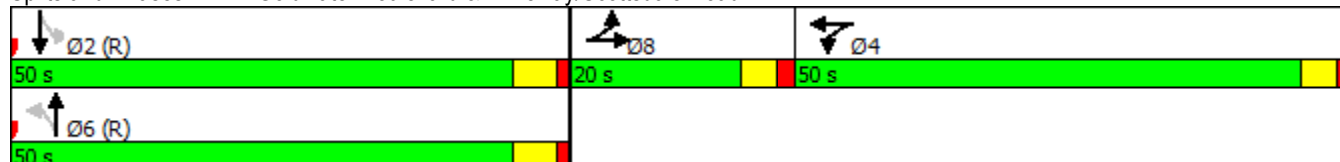













Cycle Length: 120  
 Actuated Cycle Length: 120  
 Offset: 118 (98%), Referenced to phase 2:SBTL and 6:NBTL, Start of 1st Green  
 Natural Cycle: 45  
 Control Type: Actuated-Coordinated  
 Maximum v/c Ratio: 0.63  
 Intersection Signal Delay: 18.6  
 Intersection Capacity Utilization 57.7%  
 Analysis Period (min) 15  
 Intersection LOS: B  
 ICU Level of Service B

Splits and Phases: 21: Goldwater Boulevard & Driveway/Scottsdale Road



Intersection						
Int Delay, s/veh	0					
Movement	EBL	EBT	WBT	WBR	SBL	SBR
Lane Configurations		↑↑↑	↑↑			↑
Traffic Vol, veh/h	0	453	409	7	0	2
Future Vol, veh/h	0	453	409	7	0	2
Conflicting Peds, #/hr	0	0	0	0	0	0
Sign Control	Free	Free	Free	Free	Stop	Stop
RT Channelized	-	None	-	None	-	None
Storage Length	-	-	-	-	-	0
Veh in Median Storage, #	-	0	0	-	0	-
Grade, %	-	0	0	-	0	-
Peak Hour Factor	92	92	92	92	92	92
Heavy Vehicles, %	2	2	2	2	2	2
Mvmt Flow	0	492	445	8	0	2
Major/Minor	Major1	Major2	Minor2			
Conflicting Flow All	-	0	-	0	-	226
Stage 1	-	-	-	-	-	-
Stage 2	-	-	-	-	-	-
Critical Hdwy	-	-	-	-	-	6.94
Critical Hdwy Stg 1	-	-	-	-	-	-
Critical Hdwy Stg 2	-	-	-	-	-	-
Follow-up Hdwy	-	-	-	-	-	3.32
Pot Cap-1 Maneuver	0	-	-	-	0	777
Stage 1	0	-	-	-	0	-
Stage 2	0	-	-	-	0	-
Platoon blocked, %	-	-	-	-	-	-
Mov Cap-1 Maneuver	-	-	-	-	-	777
Mov Cap-2 Maneuver	-	-	-	-	-	-
Stage 1	-	-	-	-	-	-
Stage 2	-	-	-	-	-	-
Approach	EB	WB	SB			
HCM Control Delay, s	0	0	9.6			
HCM LOS				A		
Minor Lane/Major Mvmt	EBT	WBT	WBR	SBLn1		
Capacity (veh/h)	-	-	-	777		
HCM Lane V/C Ratio	-	-	-	0.003		
HCM Control Delay (s)	-	-	-	9.6		
HCM Lane LOS	-	-	-	A		
HCM 95th %tile Q(veh)	-	-	-	0		

Intersection						
Int Delay, s/veh	0.5					
Movement	EBT	EBR	WBL	WBT	NBL	NBR
Lane Configurations						
Traffic Vol, veh/h	75	1	2	36	2	3
Future Vol, veh/h	75	1	2	36	2	3
Conflicting Peds, #/hr	0	0	0	0	0	0
Sign Control	Free	Free	Free	Free	Stop	Stop
RT Channelized	-	None	-	None	-	None
Storage Length	-	-	-	-	0	-
Veh in Median Storage, #	0	-	-	0	0	-
Grade, %	0	-	-	0	0	-
Peak Hour Factor	92	92	92	92	92	92
Heavy Vehicles, %	2	2	2	2	2	2
Mvmt Flow	82	1	2	39	2	3
Major/Minor	Major1	Major2	Minor1			
Conflicting Flow All	0	0	83	0	125	82
Stage 1	-	-	-	-	82	-
Stage 2	-	-	-	-	43	-
Critical Hdwy	-	-	4.12	-	6.42	6.22
Critical Hdwy Stg 1	-	-	-	-	5.42	-
Critical Hdwy Stg 2	-	-	-	-	5.42	-
Follow-up Hdwy	-	-	2.218	-	3.518	3.318
Pot Cap-1 Maneuver	-	-	1514	-	870	978
Stage 1	-	-	-	-	941	-
Stage 2	-	-	-	-	979	-
Platoon blocked, %	-	-	-	-	-	-
Mov Cap-1 Maneuver	-	-	1514	-	869	978
Mov Cap-2 Maneuver	-	-	-	-	869	-
Stage 1	-	-	-	-	941	-
Stage 2	-	-	-	-	978	-
Approach	EB	WB	NB			
HCM Control Delay, s	0	0.4	8.9			
HCM LOS				A		
Minor Lane/Major Mvmt	NBLn1	EBT	EBR	WBL	WBT	
Capacity (veh/h)	931	-	-	1514	-	
HCM Lane V/C Ratio	0.006	-	-	0.001	-	
HCM Control Delay (s)	8.9	-	-	7.4	0	
HCM Lane LOS	A	-	-	A	A	
HCM 95th %tile Q(veh)	0	-	-	0	-	

												
Movement	EBL	EBT	EBR	WBL	WBT	WBR	NBL	NBT	NBR	SBL	SBT	SBR
Lane Configurations												
Traffic Volume (veh/h)	12	27	25	20	38	88	32	382	27	67	911	23
Future Volume (veh/h)	12	27	25	20	38	88	32	382	27	67	911	23
Number	3	8	18	7	4	14	1	6	16	5	2	12
Initial Q (Qb), veh	0	0	0	0	0	0	0	0	0	0	0	0
Ped-Bike Adj(A_pbT)	0.84		0.75	0.79		0.75	0.98		0.87	0.97		0.88
Parking Bus, Adj	1.00	1.00	1.00	1.00	1.00	1.00	1.00	1.00	1.00	1.00	1.00	1.00
Adj Sat Flow, veh/h/ln	1900	1863	1900	1900	1863	1900	1863	1863	1900	1863	1863	1900
Adj Flow Rate, veh/h	13	29	27	22	41	96	35	415	29	73	990	25
Adj No. of Lanes	0	1	0	0	1	0	1	2	0	1	3	0
Peak Hour Factor	0.92	0.92	0.92	0.92	0.92	0.92	0.92	0.92	0.92	0.92	0.92	0.92
Percent Heavy Veh, %	2	2	2	2	2	2	2	2	2	2	2	2
Cap, veh/h	82	168	138	61	100	193	410	2243	156	632	3430	86
Arrive On Green	0.24	0.24	0.24	0.24	0.24	0.24	0.68	0.68	0.68	0.90	0.90	0.90
Sat Flow, veh/h	194	695	571	110	415	801	540	3322	231	910	5081	128
Grp Volume(v), veh/h	69	0	0	159	0	0	35	220	224	73	660	355
Grp Sat Flow(s),veh/h/ln	1459	0	0	1326	0	0	540	1770	1783	910	1695	1819
Q Serve(g_s), s	0.0	0.0	0.0	0.8	0.0	0.0	2.9	5.5	5.6	1.8	3.2	3.2
Cycle Q Clear(g_c), s	4.3	0.0	0.0	11.8	0.0	0.0	6.2	5.5	5.6	7.4	3.2	3.2
Prop In Lane	0.19		0.39	0.14		0.60	1.00		0.13	1.00		0.07
Lane Grp Cap(c), veh/h	388	0	0	354	0	0	410	1195	1204	632	2289	1228
V/C Ratio(X)	0.18	0.00	0.00	0.45	0.00	0.00	0.09	0.18	0.19	0.12	0.29	0.29
Avail Cap(c_a), veh/h	527	0	0	485	0	0	410	1195	1204	632	2289	1228
HCM Platoon Ratio	1.00	1.00	1.00	1.00	1.00	1.00	1.00	1.00	1.00	1.33	1.33	1.33
Upstream Filter(I)	1.00	0.00	0.00	1.00	0.00	0.00	1.00	1.00	1.00	1.00	1.00	1.00
Uniform Delay (d), s/veh	36.2	0.0	0.0	39.0	0.0	0.0	7.9	7.2	7.2	2.9	2.2	2.2
Incr Delay (d2), s/veh	0.1	0.0	0.0	0.3	0.0	0.0	0.4	0.3	0.3	0.4	0.3	0.6
Initial Q Delay(d3),s/veh	0.0	0.0	0.0	0.0	0.0	0.0	0.0	0.0	0.0	0.0	0.0	0.0
%ile BackOfQ(50%),veh/ln	1.8	0.0	0.0	4.5	0.0	0.0	0.5	2.8	2.9	0.5	1.5	1.7
LnGrp Delay(d),s/veh	36.2	0.0	0.0	39.3	0.0	0.0	8.3	7.6	7.6	3.3	2.5	2.7
LnGrp LOS	D			D			A	A	A	A	A	A
Approach Vol, veh/h		69			159			479			1088	
Approach Delay, s/veh		36.2			39.3			7.6			2.6	
Approach LOS		D			D			A			A	
Timer	1	2	3	4	5	6	7	8				
Assigned Phs		2		4		6		8				
Phs Duration (G+Y+Rc), s		86.2		33.8		86.2		33.8				
Change Period (Y+Rc), s		* 5.2		* 4.8		* 5.2		* 4.8				
Max Green Setting (Gmax), s		* 69		* 41		* 69		* 41				
Max Q Clear Time (g_c+I1), s		9.4		13.8		8.2		6.3				
Green Ext Time (p_c), s		0.2		0.5		0.2		0.5				
<b>Intersection Summary</b>												
HCM 2010 Ctrl Delay			8.5									
HCM 2010 LOS			A									
<b>Notes</b>												

12: Goldwater Boulevard & 2nd Street

02/22/2019

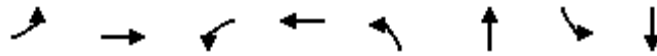

Lane Group	EBL	EBT	WBL	WBT	NBL	NBT	SBL	SBT
Lane Configurations		↕↕		↕↕	↖	↕↕	↖	↕↕↕
Traffic Volume (vph)	12	27	20	38	32	382	67	911
Future Volume (vph)	12	27	20	38	32	382	67	911
Turn Type	Perm	NA	Perm	NA	Perm	NA	Perm	NA
Protected Phases		8		4		6		2
Permitted Phases	8		4		6		2	
Detector Phase	8	8	4	4	6	6	2	2
Switch Phase								
Minimum Initial (s)	7.0	7.0	7.0	7.0	10.0	10.0	10.0	10.0
Minimum Split (s)	12.0	12.0	12.0	12.0	16.0	16.0	16.0	16.0
Total Split (s)	46.0	46.0	46.0	46.0	74.0	74.0	74.0	74.0
Total Split (%)	38.3%	38.3%	38.3%	38.3%	61.7%	61.7%	61.7%	61.7%
Yellow Time (s)	3.3	3.3	3.3	3.3	4.0	4.0	4.0	4.0
All-Red Time (s)	1.5	1.5	1.5	1.5	1.2	1.2	1.2	1.2
Lost Time Adjust (s)		0.0		0.0	0.0	0.0	0.0	0.0
Total Lost Time (s)		4.8		4.8	5.2	5.2	5.2	5.2
Lead/Lag								
Lead-Lag Optimize?								
Recall Mode	None	None	Ped	Ped	C-Max	C-Max	C-Max	C-Max
Act Effct Green (s)		29.0		29.0	81.0	81.0	81.0	81.0
Actuated g/C Ratio		0.24		0.24	0.68	0.68	0.68	0.68
v/c Ratio		0.19		0.42	0.12	0.19	0.16	0.30
Control Delay		25.0		25.0	11.3	9.9	5.6	5.0
Queue Delay		0.0		0.0	0.0	0.0	0.0	0.0
Total Delay		25.0		25.0	11.3	9.9	5.6	5.0
LOS		C		C	B	A	A	A
Approach Delay		25.0		25.0		10.0		5.1
Approach LOS		C		C		A		A

Intersection Summary

Cycle Length: 120  
 Actuated Cycle Length: 120  
 Offset: 113 (94%), Referenced to phase 2:SBTL and 6:NBTL, Start of Green  
 Natural Cycle: 40  
 Control Type: Actuated-Coordinated  
 Maximum v/c Ratio: 0.42  
 Intersection Signal Delay: 8.9  
 Intersection Capacity Utilization 63.5%  
 Analysis Period (min) 15  
 Intersection LOS: A  
 ICU Level of Service B

Splits and Phases: 12: Goldwater Boulevard & 2nd Street



**Intersection**

Int Delay, s/veh 22.8

Movement	EBL	EBT	EBR	WBL	WBT	WBR	NBL	NBT	NBR	SBL	SBT	SBR
Lane Configurations		↕			↕		↕	↕		↕	↕	↕
Traffic Vol, veh/h	12	27	25	20	38	88	32	382	27	67	911	23
Future Vol, veh/h	12	27	25	20	38	88	32	382	27	67	911	23
Conflicting Peds, #/hr	200	0	200	200	0	200	200	0	200	200	0	200
Sign Control	Stop	Stop	Stop	Stop	Stop	Stop	Free	Free	Free	Free	Free	Free
RT Channelized	-	-	None	-	-	None	-	-	None	-	-	None
Storage Length	-	-	-	-	-	-	130	-	-	80	-	-
Veh in Median Storage, #	-	0	-	-	0	-	-	0	-	-	0	-
Grade, %	-	0	-	-	0	-	-	0	-	-	0	-
Peak Hour Factor	92	92	92	92	92	92	92	92	92	92	92	92
Heavy Vehicles, %	2	2	2	2	2	2	2	2	2	2	2	2
Mvmt Flow	13	29	27	22	41	96	35	415	29	73	990	25

Major/Minor	Minor2		Minor1		Major1		Major2					
Conflicting Flow All	1846	2062	908	1455	2060	622	1215	0	0	645	0	0
Stage 1	1348	1348	-	699	699	-	-	-	-	-	-	-
Stage 2	498	714	-	756	1361	-	-	-	-	-	-	-
Critical Hdwy	6.99	6.54	7.14	6.99	6.54	6.94	5.34	-	-	4.14	-	-
Critical Hdwy Stg 1	7.34	5.54	-	6.54	5.54	-	-	-	-	-	-	-
Critical Hdwy Stg 2	6.54	5.54	-	6.74	5.54	-	-	-	-	-	-	-
Follow-up Hdwy	3.67	4.02	3.92	3.67	4.02	3.32	3.12	-	-	2.22	-	-
Pot Cap-1 Maneuver	150	112	*716	*319	112	430	660	-	-	936	-	-
Stage 1	373	439	-	*385	440	-	-	-	-	-	-	-
Stage 2	506	433	-	*765	431	-	-	-	-	-	-	-
Platoon blocked, %	1	1	1	1	1	1	-	-	-	-	-	-
Mov Cap-1 Maneuver	32	66	*497	*122	66	299	550	-	-	780	-	-
Mov Cap-2 Maneuver	32	66	-	*122	66	-	-	-	-	-	-	-
Stage 1	291	332	-	*300	343	-	-	-	-	-	-	-
Stage 2	236	338	-	*498	326	-	-	-	-	-	-	-





















Approach	EB		WB		NB		SB	
HCM Control Delay, s	169.6		175.9		0.9		0.7	
HCM LOS	F		F					

Minor Lane/Major Mvmt	NBL	NBT	NBR	EBLn1WBLn1	SBL	SBT	SBR
Capacity (veh/h)	550	-	-	77	141	780	-
HCM Lane V/C Ratio	0.063	-	-	0.903	1.126	0.093	-
HCM Control Delay (s)	12	-	-	169.6	175.9	10.1	-
HCM Lane LOS	B	-	-	F	F	B	-
HCM 95th %tile Q(veh)	0.2	-	-	4.7	8.9	0.3	-

**Notes**

~: Volume exceeds capacity    \$: Delay exceeds 300s    +: Computation Not Defined    \*: All major volume in platoon

Intersection												
Intersection Delay, s/veh	7.9											
Intersection LOS	A											
Movement	EBL	EBT	EBR	WBL	WBT	WBR	NBL	NBT	NBR	SBL	SBT	SBR
Lane Configurations		↕			↕			↕			↕	
Traffic Vol, veh/h	12	54	29	6	92	3	25	25	4	7	36	21
Future Vol, veh/h	12	54	29	6	92	3	25	25	4	7	36	21
Peak Hour Factor	0.92	0.92	0.92	0.92	0.92	0.92	0.92	0.92	0.92	0.92	0.92	0.92
Heavy Vehicles, %	2	2	2	2	2	2	2	2	2	2	2	2
Mvmt Flow	13	59	32	7	100	3	27	27	4	8	39	23
Number of Lanes	0	1	0	0	1	0	0	1	0	0	1	0
Approach	EB			WB			NB			SB		
Opposing Approach	WB			EB			SB			NB		
Opposing Lanes	1			1			1			1		
Conflicting Approach Left	SB			NB			EB			WB		
Conflicting Lanes Left	1			1			1			1		
Conflicting Approach Right	NB			SB			WB			EB		
Conflicting Lanes Right	1			1			1			1		
HCM Control Delay	7.8			8			7.9			7.7		
HCM LOS	A			A			A			A		
Lane	NBLn1	EBLn1	WBLn1	SBLn1								
Vol Left, %	46%	13%	6%	11%								
Vol Thru, %	46%	57%	91%	56%								
Vol Right, %	7%	31%	3%	33%								
Sign Control	Stop	Stop	Stop	Stop								
Traffic Vol by Lane	54	95	101	64								
LT Vol	25	12	6	7								
Through Vol	25	54	92	36								
RT Vol	4	29	3	21								
Lane Flow Rate	59	103	110	70								
Geometry Grp	1	1	1	1								
Degree of Util (X)	0.074	0.12	0.132	0.083								
Departure Headway (Hd)	4.532	4.188	4.34	4.299								
Convergence, Y/N	Yes	Yes	Yes	Yes								
Cap	793	859	831	836								
Service Time	2.545	2.199	2.34	2.312								
HCM Lane V/C Ratio	0.074	0.12	0.132	0.084								
HCM Control Delay	7.9	7.8	8	7.7								
HCM Lane LOS	A	A	A	A								
HCM 95th-tile Q	0.2	0.4	0.5	0.3								

												
Movement	EBL	EBT	EBR	WBL	WBT	WBR	NBL	NBT	NBR	SBL	SBT	SBR
Lane Configurations												
Traffic Volume (veh/h)	43	29	14	31	52	32	10	440	44	31	550	42
Future Volume (veh/h)	43	29	14	31	52	32	10	440	44	31	550	42
Number	3	8	18	7	4	14	1	6	16	5	2	12
Initial Q (Qb), veh	0	0	0	0	0	0	0	0	0	0	0	0
Ped-Bike Adj(A_pbT)	0.84		0.79	0.81		0.79	0.92		0.80	0.93		0.81
Parking Bus, Adj	1.00	1.00	0.90	1.00	1.00	1.00	1.00	1.00	1.00	1.00	1.00	1.00
Adj Sat Flow, veh/h/ln	1863	1863	1863	1900	1863	1900	1863	1863	1900	1863	1863	1900
Adj Flow Rate, veh/h	47	32	15	34	57	35	11	478	48	34	598	46
Adj No. of Lanes	1	1	1	0	1	0	1	2	0	1	2	0
Peak Hour Factor	0.92	0.92	0.92	0.92	0.92	0.92	0.92	0.92	0.92	0.92	0.92	0.92
Percent Heavy Veh, %	2	2	2	2	2	2	2	2	2	2	2	2
Cap, veh/h	457	538	326	154	230	118	510	1709	170	491	1765	135
Arrive On Green	0.29	0.29	0.29	0.29	0.29	0.29	0.54	0.54	0.54	1.00	1.00	1.00
Sat Flow, veh/h	1086	1863	1129	269	797	410	723	3168	315	813	3270	251
Grp Volume(v), veh/h	47	32	15	126	0	0	11	265	261	34	323	321
Grp Sat Flow(s),veh/h/ln	1086	1863	1129	1476	0	0	723	1770	1713	813	1770	1751
Q Serve(g_s), s	0.0	0.7	0.6	0.0	0.0	0.0	0.4	4.9	5.0	0.4	0.0	0.0
Cycle Q Clear(g_c), s	1.4	0.7	0.6	3.5	0.0	0.0	0.4	4.9	5.0	5.4	0.0	0.0
Prop In Lane	1.00		1.00	0.27		0.28	1.00		0.18	1.00		0.14
Lane Grp Cap(c), veh/h	457	538	326	502	0	0	510	955	924	491	955	945
V/C Ratio(X)	0.10	0.06	0.05	0.25	0.00	0.00	0.02	0.28	0.28	0.07	0.34	0.34
Avail Cap(c_a), veh/h	556	708	429	631	0	0	510	955	924	491	955	945
HCM Platoon Ratio	1.00	1.00	1.00	1.00	1.00	1.00	1.00	1.00	1.00	2.00	2.00	2.00
Upstream Filter(I)	1.00	1.00	1.00	1.00	0.00	0.00	1.00	1.00	1.00	0.99	0.99	0.99
Uniform Delay (d), s/veh	15.7	15.4	15.4	16.4	0.0	0.0	6.5	7.5	7.5	0.4	0.0	0.0
Incr Delay (d2), s/veh	0.0	0.0	0.0	0.1	0.0	0.0	0.1	0.7	0.8	0.3	0.9	1.0
Initial Q Delay(d3),s/veh	0.0	0.0	0.0	0.0	0.0	0.0	0.0	0.0	0.0	0.0	0.0	0.0
%ile BackOfQ(50%),veh/ln	0.6	0.4	0.2	1.6	0.0	0.0	0.1	2.5	2.5	0.1	0.3	0.3
LnGrp Delay(d),s/veh	15.7	15.5	15.4	16.5	0.0	0.0	6.5	8.2	8.3	0.7	0.9	1.0
LnGrp LOS	B	B	B	B			A	A	A	A	A	A
Approach Vol, veh/h		94			126			537			678	
Approach Delay, s/veh		15.6			16.5			8.2			0.9	
Approach LOS		B			B			A			A	
Timer	1	2	3	4	5	6	7	8				
Assigned Phs		2		4		6		8				
Phs Duration (G+Y+Rc), s		37.5		22.5		37.5		22.5				
Change Period (Y+Rc), s		5.1		* 5.2		5.1		* 5.2				
Max Green Setting (Gmax), s		26.9		* 23		26.9		* 23				
Max Q Clear Time (g_c+I1), s		7.4		5.5		7.0		3.4				
Green Ext Time (p_c), s		0.4		0.6		0.4		0.6				
<b>Intersection Summary</b>												
HCM 2010 Ctrl Delay			6.0									
HCM 2010 LOS			A									
<b>Notes</b>												

17: Scottsdale Road & 2nd Street

02/22/2019

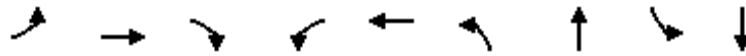

Lane Group	EBL	EBT	EBR	WBL	WBT	NBL	NBT	SBL	SBT
Lane Configurations	↙	↑	↘		↔	↙	↕	↙	↕
Traffic Volume (vph)	43	29	14	31	52	10	440	31	550
Future Volume (vph)	43	29	14	31	52	10	440	31	550
Turn Type	Perm	NA	Perm	Perm	NA	Perm	NA	Perm	NA
Protected Phases		8			4		6		2
Permitted Phases	8		8	4		6		2	
Detector Phase	8	8	8	4	4	6	6	2	2
Switch Phase									
Minimum Initial (s)	6.0	6.0	6.0	6.0	6.0	10.0	10.0	10.0	10.0
Minimum Split (s)	25.2	25.2	25.2	25.2	25.2	26.0	26.0	26.0	26.0
Total Split (s)	28.0	28.0	28.0	28.0	28.0	32.0	32.0	32.0	32.0
Total Split (%)	46.7%	46.7%	46.7%	46.7%	46.7%	53.3%	53.3%	53.3%	53.3%
Yellow Time (s)	3.0	3.0	3.0	3.0	3.0	3.0	3.0	3.0	3.0
All-Red Time (s)	2.2	2.2	2.2	2.2	2.2	2.1	2.1	2.1	2.1
Lost Time Adjust (s)	0.0	0.0	0.0		0.0	0.0	0.0	0.0	0.0
Total Lost Time (s)	5.2	5.2	5.2		5.2	5.1	5.1	5.1	5.1
Lead/Lag									
Lead-Lag Optimize?									
Recall Mode	None	None	None	None	None	C-Min	C-Min	C-Min	C-Min
Act Effct Green (s)	8.6	8.6	8.6		8.6	44.4	44.4	44.4	44.4
Actuated g/C Ratio	0.14	0.14	0.14		0.14	0.74	0.74	0.74	0.74
v/c Ratio	0.31	0.13	0.08		0.53	0.02	0.21	0.06	0.25
Control Delay	27.5	22.2	3.6		25.4	2.4	2.0	3.0	2.6
Queue Delay	0.0	0.0	0.0		0.0	0.0	0.0	0.0	0.0
Total Delay	27.5	22.2	3.6		25.4	2.4	2.0	3.0	2.6
LOS	C	C	A		C	A	A	A	A
Approach Delay		21.9			25.4		2.1		2.6
Approach LOS		C			C		A		A

Intersection Summary

Cycle Length: 60  
 Actuated Cycle Length: 60  
 Offset: 0 (0%), Referenced to phase 2:SBTL and 6:NBTL, Start of 1st Green  
 Natural Cycle: 55  
 Control Type: Actuated-Coordinated  
 Maximum v/c Ratio: 0.53  
 Intersection Signal Delay: 5.7  
 Intersection Capacity Utilization 63.3%  
 Analysis Period (min) 15  
 Intersection LOS: A  
 ICU Level of Service B

Splits and Phases: 17: Scottsdale Road & 2nd Street

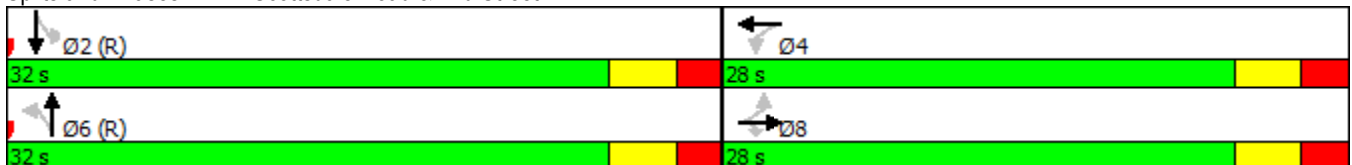

Intersection						
Int Delay, s/veh	3.1					
Movement	SET	SER	NWL	NWT	NEL	NER
Lane Configurations	↑↑↑		↘	↑↑	↘	↘
Traffic Vol, veh/h	761	190	29	342	89	19
Future Vol, veh/h	761	190	29	342	89	19
Conflicting Peds, #/hr	0	9	9	0	2	0
Sign Control	Free	Free	Free	Free	Stop	Stop
RT Channelized	-	None	-	None	-	None
Storage Length	-	-	70	-	0	0
Veh in Median Storage, #	0	-	-	0	0	-
Grade, %	0	-	-	0	0	-
Peak Hour Factor	92	92	92	92	92	92
Heavy Vehicles, %	2	2	2	2	2	2
Mvmt Flow	827	207	32	372	97	21

Major/Minor	Major1	Major2	Minor1			
Conflicting Flow All	0	0	1043	0	1190	526
Stage 1	-	-	-	-	939	-
Stage 2	-	-	-	-	251	-
Critical Hdwy	-	-	5.34	-	6.29	7.14
Critical Hdwy Stg 1	-	-	-	-	6.64	-
Critical Hdwy Stg 2	-	-	-	-	5.84	-
Follow-up Hdwy	-	-	3.12	-	3.67	3.92
Pot Cap-1 Maneuver	-	-	373	-	212	425
Stage 1	-	-	-	-	270	-
Stage 2	-	-	-	-	740	-
Platoon blocked, %	-	-	-	-	-	-
Mov Cap-1 Maneuver	-	-	373	-	192	422
Mov Cap-2 Maneuver	-	-	-	-	192	-
Stage 1	-	-	-	-	268	-
Stage 2	-	-	-	-	675	-

Approach	SE	NW	NE
HCM Control Delay, s	0	1.2	36.6
HCM LOS			E

Minor Lane/Major Mvmt	NELn1	NELn2	NWL	NWT	SET	SER
Capacity (veh/h)	192	422	373	-	-	-
HCM Lane V/C Ratio	0.504	0.049	0.085	-	-	-
HCM Control Delay (s)	41.4	14	15.5	-	-	-
HCM Lane LOS	E	B	C	-	-	-
HCM 95th %tile Q(veh)	2.5	0.2	0.3	-	-	-

Intersection												
Int Delay, s/veh	2.4											
Movement	EBL	EBT	EBR	WBL	WBT	WBR	NBL	NBT	NBR	SBL	SBT	SBR
Lane Configurations	↖ ↑↑↑ ↗			↖ ↑↑			↔			↖ ↗		
Traffic Vol, veh/h	17	730	34	11	329	53	25	8	8	52	10	17
Future Vol, veh/h	17	730	34	11	329	53	25	8	8	52	10	17
Conflicting Peds, #/hr	3	0	12	12	0	3	8	0	1	1	0	8
Sign Control	Free	Free	Free	Free	Free	Free	Stop	Stop	Stop	Stop	Stop	Stop
RT Channelized	-	-	None	-	-	None	-	-	None	-	-	None
Storage Length	100	-	-	70	-	-	-	-	-	55	-	-
Veh in Median Storage, #	-	0	-	-	0	-	-	0	-	-	0	-
Grade, %	-	0	-	-	0	-	-	0	-	-	0	-
Peak Hour Factor	92	92	92	92	92	92	92	92	92	92	92	92
Heavy Vehicles, %	2	2	2	2	2	2	2	2	2	2	2	2
Mvmt Flow	18	793	37	12	358	58	27	9	9	57	11	18

Major/Minor	Major1			Major2			Minor1			Minor2		
Conflicting Flow All	418	0	0	842	0	0	1077	1303	428	773	1292	219
Stage 1	-	-	-	-	-	-	861	861	-	413	413	-
Stage 2	-	-	-	-	-	-	216	442	-	360	879	-
Critical Hdwy	4.14	-	-	5.34	-	-	6.99	6.54	7.14	6.99	6.54	6.94
Critical Hdwy Stg 1	-	-	-	-	-	-	7.34	5.54	-	6.54	5.54	-
Critical Hdwy Stg 2	-	-	-	-	-	-	6.54	5.54	-	6.74	5.54	-
Follow-up Hdwy	2.22	-	-	3.12	-	-	3.67	4.02	3.92	3.67	4.02	3.32
Pot Cap-1 Maneuver	1138	-	-	466	-	-	200	159	492	316	162	785
Stage 1	-	-	-	-	-	-	255	371	-	568	592	-
Stage 2	-	-	-	-	-	-	738	575	-	597	363	-
Platoon blocked, %	-	-	-	-	-	-	-	-	-	-	-	-
Mov Cap-1 Maneuver	1130	-	-	466	-	-	176	151	487	286	153	778
Mov Cap-2 Maneuver	-	-	-	-	-	-	176	151	-	286	153	-
Stage 1	-	-	-	-	-	-	248	361	-	558	575	-
Stage 2	-	-	-	-	-	-	684	559	-	563	354	-

Approach	EB			WB			NB			SB		
HCM Control Delay, s	0.2			0.4			29			19.7		
HCM LOS							D			C		

Minor Lane/Major Mvmt	NBLn1	EBL	EBT	EBR	WBL	WBT	WBR	SBLn1	SBLn2
Capacity (veh/h)	194	1130	-	-	466	-	-	286	310
HCM Lane V/C Ratio	0.23	0.016	-	-	0.026	-	-	0.198	0.095
HCM Control Delay (s)	29	8.2	-	-	12.9	-	-	20.7	17.8
HCM Lane LOS	D	A	-	-	B	-	-	C	C
HCM 95th %tile Q(veh)	0.9	0.1	-	-	0.1	-	-	0.7	0.3

Movement	EBL	EBT	EBR	WBL	WBT	WBR	NBL	NBT	NBR	SBL	SBT	SBR
Lane Configurations												
Traffic Volume (veh/h)	14	6	12	621	23	20	21	355	13	23	770	21
Future Volume (veh/h)	14	6	12	621	23	20	21	355	13	23	770	21
Number	3	8	18	7	4	14	1	6	16	5	2	12
Initial Q (Qb), veh	0	0	0	0	0	0	0	0	0	0	0	0
Ped-Bike Adj(A_pbT)	1.00		0.83	1.00		1.00	1.00		0.97	1.00		0.97
Parking Bus, Adj	1.00	1.00	1.00	1.00	1.00	1.00	1.00	1.00	1.00	1.00	1.00	1.00
Adj Sat Flow, veh/h/ln	1863	1863	1900	1863	1863	1900	1863	1863	1900	1863	1863	1900
Adj Flow Rate, veh/h	15	7	13	713	0	0	23	386	14	25	837	23
Adj No. of Lanes	1	1	0	2	1	0	1	2	0	1	3	0
Peak Hour Factor	0.92	0.92	0.92	0.92	0.92	0.92	0.92	0.92	0.92	0.92	0.92	0.92
Percent Heavy Veh, %	2	2	2	2	2	2	2	2	2	2	2	2
Cap, veh/h	102	30	55	848	445	0	376	2012	73	573	2939	81
Arrive On Green	0.06	0.06	0.06	0.24	0.00	0.00	0.58	0.58	0.58	0.58	0.58	0.58
Sat Flow, veh/h	1774	512	951	3548	1863	0	639	3479	126	977	5083	139
Grp Volume(v), veh/h	15	0	20	713	0	0	23	196	204	25	558	302
Grp Sat Flow(s),veh/h/ln	1774	0	1463	1774	1863	0	639	1770	1836	977	1695	1833
Q Serve(g_s), s	1.0	0.0	1.6	23.0	0.0	0.0	2.3	6.3	6.3	1.5	10.0	10.0
Cycle Q Clear(g_c), s	1.0	0.0	1.6	23.0	0.0	0.0	12.3	6.3	6.3	7.8	10.0	10.0
Prop In Lane	1.00		0.65	1.00		0.00	1.00		0.07	1.00		0.08
Lane Grp Cap(c), veh/h	102	0	84	848	445	0	376	1023	1061	573	1960	1060
V/C Ratio(X)	0.15	0.00	0.24	0.84	0.00	0.00	0.06	0.19	0.19	0.04	0.28	0.29
Avail Cap(c_a), veh/h	149	0	123	1570	824	0	376	1023	1061	573	1960	1060
HCM Platoon Ratio	1.00	1.00	1.00	1.00	1.00	1.00	1.00	1.00	1.00	1.00	1.00	1.00
Upstream Filter(I)	1.00	0.00	1.00	1.00	0.00	0.00	1.00	1.00	1.00	1.00	1.00	1.00
Uniform Delay (d), s/veh	53.7	0.0	54.0	43.5	0.0	0.0	15.9	12.0	12.0	13.9	12.8	12.8
Incr Delay (d2), s/veh	0.2	0.0	0.5	0.9	0.0	0.0	0.3	0.4	0.4	0.1	0.4	0.7
Initial Q Delay(d3),s/veh	0.0	0.0	0.0	0.0	0.0	0.0	0.0	0.0	0.0	0.0	0.0	0.0
%ile BackOfQ(50%),veh/ln	0.5	0.0	0.6	11.4	0.0	0.0	0.4	3.2	3.3	0.4	4.7	5.2
LnGrp Delay(d),s/veh	54.0	0.0	54.5	44.4	0.0	0.0	16.2	12.4	12.4	14.0	13.1	13.5
LnGrp LOS	D		D	D			B	B	B	B	B	B
Approach Vol, veh/h		35			713			423			885	
Approach Delay, s/veh		54.3			44.4			12.6			13.3	
Approach LOS		D			D			B			B	
Timer	1	2	3	4	5	6	7	8				
Assigned Phs		2		4		6		8				
Phs Duration (G+Y+Rc), s		74.6		33.6		74.6		11.8				
Change Period (Y+Rc), s		* 5.2		* 4.9		* 5.2		4.9				
Max Green Setting (Gmax), s		* 42		* 53		* 42		10.1				
Max Q Clear Time (g_c+I1), s		12.0		25.0		14.3		3.6				
Green Ext Time (p_c), s		2.2		1.5		2.2		0.0				
<b>Intersection Summary</b>												
HCM 2010 Ctrl Delay				24.6								
HCM 2010 LOS				C								
<b>Notes</b>												

21: Goldwater Boulevard & Driveway/Scottsdale Road

02/22/2019

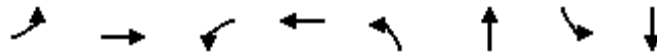

Lane Group	EBL	EBT	WBL	WBT	NBL	NBT	SBL	SBT
Lane Configurations								
Traffic Volume (vph)	14	6	621	23	21	355	23	770
Future Volume (vph)	14	6	621	23	21	355	23	770
Turn Type	Split	NA	Split	NA	Perm	NA	Perm	NA
Protected Phases	8	8	4	4		6		2
Permitted Phases					6		2	
Detector Phase	8	8	4	4	6	6	2	2
Switch Phase								
Minimum Initial (s)	7.0	7.0	7.0	7.0	10.0	10.0	10.0	10.0
Minimum Split (s)	13.0	13.0	13.0	13.0	16.0	16.0	16.0	16.0
Total Split (s)	15.0	15.0	58.0	58.0	47.0	47.0	47.0	47.0
Total Split (%)	12.5%	12.5%	48.3%	48.3%	39.2%	39.2%	39.2%	39.2%
Yellow Time (s)	3.3	3.3	3.3	3.3	4.0	4.0	4.0	4.0
All-Red Time (s)	1.6	1.6	1.6	1.6	1.2	1.2	1.2	1.2
Lost Time Adjust (s)	0.0	0.0	0.0	0.0	0.0	0.0	0.0	0.0
Total Lost Time (s)	4.9	4.9	4.9	4.9	5.2	5.2	5.2	5.2
Lead/Lag	Lead	Lead	Lag	Lag				
Lead-Lag Optimize?								
Recall Mode	None	None	Ped	Ped	C-Max	C-Max	C-Max	C-Max
Act Effct Green (s)	7.6	7.6	34.5	34.5	67.7	67.7	67.7	67.7
Actuated g/C Ratio	0.06	0.06	0.29	0.29	0.56	0.56	0.56	0.56
v/c Ratio	0.13	0.19	0.76	0.74	0.08	0.20	0.05	0.30
Control Delay	55.1	57.1	47.3	46.0	17.0	13.4	10.8	10.1
Queue Delay	0.0	0.0	0.0	0.0	0.0	0.0	0.0	0.0
Total Delay	55.1	57.1	47.3	46.0	17.0	13.4	10.8	10.1
LOS	E	E	D	D	B	B	B	B
Approach Delay		56.2		46.6		13.6		10.1
Approach LOS		E		D		B		B

Intersection Summary

Cycle Length: 120  
 Actuated Cycle Length: 120  
 Offset: 60 (50%), Referenced to phase 2:SBTL and 6:NBTL, Start of 1st Green  
 Natural Cycle: 55  
 Control Type: Actuated-Coordinated  
 Maximum v/c Ratio: 0.76  
 Intersection Signal Delay: 24.4  
 Intersection Capacity Utilization 54.2%  
 Analysis Period (min) 15

Intersection LOS: C  
 ICU Level of Service A

Splits and Phases: 21: Goldwater Boulevard & Driveway/Scottsdale Road

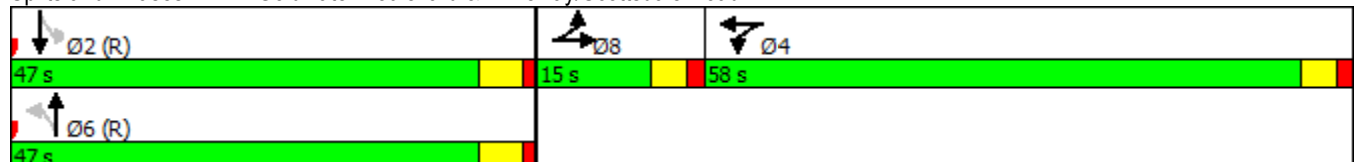



















Intersection						
Int Delay, s/veh	0.1					
Movement	EBL	EBT	WBT	WBR	SBL	SBR
Lane Configurations		↑↑↑	↑↑			↑
Traffic Vol, veh/h	0	790	393	28	0	10
Future Vol, veh/h	0	790	393	28	0	10
Conflicting Peds, #/hr	0	0	0	0	0	0
Sign Control	Free	Free	Free	Free	Stop	Stop
RT Channelized	-	None	-	None	-	None
Storage Length	-	-	-	-	-	0
Veh in Median Storage, #	-	0	0	-	0	-
Grade, %	-	0	0	-	0	-
Peak Hour Factor	92	92	92	92	92	92
Heavy Vehicles, %	2	2	2	2	2	2
Mvmt Flow	0	859	427	30	0	11
Major/Minor	Major1	Major2	Minor2			
Conflicting Flow All	-	0	-	0	-	229
Stage 1	-	-	-	-	-	-
Stage 2	-	-	-	-	-	-
Critical Hdwy	-	-	-	-	-	6.94
Critical Hdwy Stg 1	-	-	-	-	-	-
Critical Hdwy Stg 2	-	-	-	-	-	-
Follow-up Hdwy	-	-	-	-	-	3.32
Pot Cap-1 Maneuver	0	-	-	-	0	774
Stage 1	0	-	-	-	0	-
Stage 2	0	-	-	-	0	-
Platoon blocked, %	-	-	-	-	-	-
Mov Cap-1 Maneuver	-	-	-	-	-	774
Mov Cap-2 Maneuver	-	-	-	-	-	-
Stage 1	-	-	-	-	-	-
Stage 2	-	-	-	-	-	-
Approach	EB	WB	SB			
HCM Control Delay, s	0	0	9.7			
HCM LOS						A
Minor Lane/Major Mvmt	EBT	WBT	WBR	SBLn1		
Capacity (veh/h)	-	-	-	774		
HCM Lane V/C Ratio	-	-	-	0.014		
HCM Control Delay (s)	-	-	-	9.7		
HCM Lane LOS	-	-	-	A		
HCM 95th %tile Q(veh)	-	-	-	0		

Intersection						
Int Delay, s/veh	1.8					
Movement	EBT	EBR	WBL	WBT	NBL	NBR
Lane Configurations						
Traffic Vol, veh/h	65	3	13	101	9	23
Future Vol, veh/h	65	3	13	101	9	23
Conflicting Peds, #/hr	0	0	0	0	0	0
Sign Control	Free	Free	Free	Free	Stop	Stop
RT Channelized	-	None	-	None	-	None
Storage Length	-	-	-	-	0	-
Veh in Median Storage, #	0	-	-	0	0	-
Grade, %	0	-	-	0	0	-
Peak Hour Factor	92	92	92	92	92	92
Heavy Vehicles, %	2	2	2	2	2	2
Mvmt Flow	71	3	14	110	10	25
Major/Minor	Major1	Major2	Minor1			
Conflicting Flow All	0	0	74	0	210	72
Stage 1	-	-	-	-	72	-
Stage 2	-	-	-	-	138	-
Critical Hdwy	-	-	4.12	-	6.42	6.22
Critical Hdwy Stg 1	-	-	-	-	5.42	-
Critical Hdwy Stg 2	-	-	-	-	5.42	-
Follow-up Hdwy	-	-	2.218	-	3.518	3.318
Pot Cap-1 Maneuver	-	-	1526	-	778	990
Stage 1	-	-	-	-	951	-
Stage 2	-	-	-	-	889	-
Platoon blocked, %	-	-	-	-	-	-
Mov Cap-1 Maneuver	-	-	1526	-	770	990
Mov Cap-2 Maneuver	-	-	-	-	770	-
Stage 1	-	-	-	-	951	-
Stage 2	-	-	-	-	880	-
Approach	EB	WB	NB			
HCM Control Delay, s	0	0.8	9.1			
HCM LOS				A		
Minor Lane/Major Mvmt	NBLn1	EBT	EBR	WBL	WBT	
Capacity (veh/h)	916	-	-	1526	-	
HCM Lane V/C Ratio	0.038	-	-	0.009	-	
HCM Control Delay (s)	9.1	-	-	7.4	0	
HCM Lane LOS	A	-	-	A	A	
HCM 95th %tile Q(veh)	0.1	-	-	0	-	

## ATTACHMENT J – YEAR 2025 BUILD CAPACITY ANALYSIS

Some of the Synchro outputs under Attachment I are taken directly from the Museum Square Traffic Impact & Mitigation Analysis, dated August 10, 2018. For organizational purposes, the intersections for the Museum Square Traffic Impact & Mitigation Analysis have been changed to:

<b>Intersection</b>	<b>August 10, 2018 TI&amp;MA Intersection Number</b>	<b>2nd Street and Bishop TI&amp;MA Intersection Number</b>
Goldwater Boulevard and 2nd Street	12	1
Marshall Way and 2nd Street	16	2
Scottsdale Road and 2nd Street	17	3
Goldwater Boulevard and 70th Street	18	4
Goldwater Boulevard and Marshall Way	20	5
Goldwater Boulevard and Scottsdale Road	21	7

												
Movement	EBL	EBT	EBR	WBL	WBT	WBR	NBL	NBT	NBR	SBL	SBT	SBR
Lane Configurations												
Traffic Volume (veh/h)	18	34	15	12	10	49	11	466	16	65	504	18
Future Volume (veh/h)	18	34	15	12	10	49	11	466	16	65	504	18
Number	3	8	18	7	4	14	1	6	16	5	2	12
Initial Q (Qb), veh	0	0	0	0	0	0	0	0	0	0	0	0
Ped-Bike Adj(A_pbT)	0.79		0.75	0.79		0.75	0.94		0.87	0.97		0.86
Parking Bus, Adj	1.00	1.00	1.00	1.00	1.00	1.00	1.00	1.00	1.00	1.00	1.00	1.00
Adj Sat Flow, veh/h/ln	1900	1863	1900	1900	1863	1900	1863	1863	1900	1863	1863	1900
Adj Flow Rate, veh/h	20	37	16	13	11	53	12	507	17	71	548	20
Adj No. of Lanes	0	1	0	0	1	0	1	2	0	1	3	0
Peak Hour Factor	0.92	0.92	0.92	0.92	0.92	0.92	0.92	0.92	0.92	0.92	0.92	0.92
Percent Heavy Veh, %	2	2	2	2	2	2	2	2	2	2	2	2
Cap, veh/h	114	197	77	69	61	210	595	2347	79	588	3379	122
Arrive On Green	0.24	0.24	0.24	0.24	0.24	0.24	0.68	0.68	0.68	1.00	1.00	1.00
Sat Flow, veh/h	315	816	317	142	252	870	793	3476	116	852	5005	181
Grp Volume(v), veh/h	73	0	0	77	0	0	12	258	266	71	370	198
Grp Sat Flow(s),veh/h/ln	1448	0	0	1263	0	0	793	1770	1822	852	1695	1796
Q Serve(g_s), s	0.0	0.0	0.0	0.0	0.0	0.0	0.6	6.6	6.7	0.9	0.0	0.0
Cycle Q Clear(g_c), s	4.2	0.0	0.0	5.5	0.0	0.0	0.6	6.6	6.7	7.6	0.0	0.0
Prop In Lane	0.27		0.22	0.17		0.69	1.00		0.06	1.00		0.10
Lane Grp Cap(c), veh/h	388	0	0	340	0	0	595	1195	1230	588	2289	1212
V/C Ratio(X)	0.19	0.00	0.00	0.23	0.00	0.00	0.02	0.22	0.22	0.12	0.16	0.16
Avail Cap(c_a), veh/h	484	0	0	424	0	0	595	1195	1230	588	2289	1212
HCM Platoon Ratio	1.00	1.00	1.00	1.00	1.00	1.00	1.00	1.00	1.00	2.00	2.00	2.00
Upstream Filter(I)	1.00	0.00	0.00	1.00	0.00	0.00	1.00	1.00	1.00	1.00	1.00	1.00
Uniform Delay (d), s/veh	36.1	0.0	0.0	36.6	0.0	0.0	6.4	7.4	7.4	0.3	0.0	0.0
Incr Delay (d2), s/veh	0.1	0.0	0.0	0.1	0.0	0.0	0.1	0.4	0.4	0.4	0.2	0.3
Initial Q Delay(d3),s/veh	0.0	0.0	0.0	0.0	0.0	0.0	0.0	0.0	0.0	0.0	0.0	0.0
%ile BackOfQ(50%),veh/ln	1.9	0.0	0.0	2.1	0.0	0.0	0.1	3.4	3.5	0.3	0.0	0.1
LnGrp Delay(d),s/veh	36.2	0.0	0.0	36.7	0.0	0.0	6.5	7.8	7.8	0.7	0.2	0.3
LnGrp LOS	D			D			A	A	A	A	A	A
Approach Vol, veh/h		73			77			536			639	
Approach Delay, s/veh		36.2			36.7			7.8			0.3	
Approach LOS		D			D			A			A	
Timer	1	2	3	4	5	6	7	8				
Assigned Phs		2		4		6		8				
Phs Duration (G+Y+Rc), s		86.2		33.8		86.2		33.8				
Change Period (Y+Rc), s		* 5.2		* 4.8		* 5.2		* 4.8				
Max Green Setting (Gmax), s		* 73		* 37		* 73		* 37				
Max Q Clear Time (g_c+I1), s		9.6		7.5		8.7		6.2				
Green Ext Time (p_c), s		0.2		0.3		0.2		0.3				
<b>Intersection Summary</b>												
HCM 2010 Ctrl Delay			7.4									
HCM 2010 LOS			A									
<b>Notes</b>												

12: Goldwater Boulevard & 2nd Street

02/26/2019

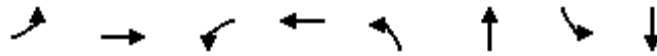

Lane Group	EBL	EBT	WBL	WBT	NBL	NBT	SBL	SBT
Lane Configurations		↕		↕	↙	↕	↙	↕↕↕
Traffic Volume (vph)	18	34	12	10	11	466	65	504
Future Volume (vph)	18	34	12	10	11	466	65	504
Turn Type	Perm	NA	Perm	NA	Perm	NA	Perm	NA
Protected Phases		8		4		6		2
Permitted Phases	8		4		6		2	
Detector Phase	8	8	4	4	6	6	2	2
Switch Phase								
Minimum Initial (s)	7.0	7.0	7.0	7.0	10.0	10.0	10.0	10.0
Minimum Split (s)	12.0	12.0	12.0	12.0	16.0	16.0	16.0	16.0
Total Split (s)	42.0	42.0	42.0	42.0	78.0	78.0	78.0	78.0
Total Split (%)	35.0%	35.0%	35.0%	35.0%	65.0%	65.0%	65.0%	65.0%
Yellow Time (s)	3.3	3.3	3.3	3.3	4.0	4.0	4.0	4.0
All-Red Time (s)	1.5	1.5	1.5	1.5	1.2	1.2	1.2	1.2
Lost Time Adjust (s)		0.0		0.0	0.0	0.0	0.0	0.0
Total Lost Time (s)		4.8		4.8	5.2	5.2	5.2	5.2
Lead/Lag								
Lead-Lag Optimize?								
Recall Mode	Ped	Ped	None	None	C-Max	C-Max	C-Max	C-Max
Act Effct Green (s)		29.0		29.0	81.0	81.0	81.0	81.0
Actuated g/C Ratio		0.24		0.24	0.68	0.68	0.68	0.68
v/c Ratio		0.20		0.22	0.03	0.22	0.17	0.17
Control Delay		31.9		16.5	7.7	6.7	7.5	6.4
Queue Delay		0.0		0.0	0.0	0.0	0.0	0.0
Total Delay		31.9		16.5	7.7	6.7	7.5	6.4
LOS		C		B	A	A	A	A
Approach Delay		31.9		16.5		6.7		6.5
Approach LOS		C		B		A		A

Intersection Summary

Cycle Length: 120  
 Actuated Cycle Length: 120  
 Offset: 42 (35%), Referenced to phase 2:SBTL and 6:NBTL, Start of Green  
 Natural Cycle: 40  
 Control Type: Actuated-Coordinated  
 Maximum v/c Ratio: 0.22  
 Intersection Signal Delay: 8.6  
 Intersection Capacity Utilization 61.0%  
 Analysis Period (min) 15  
 Intersection LOS: A  
 ICU Level of Service B

Splits and Phases: 12: Goldwater Boulevard & 2nd Street



Intersection												
Int Delay, s/veh	7.3											
Movement	EBL	EBT	EBR	WBL	WBT	WBR	NBL	NBT	NBR	SBL	SBT	SBR
Lane Configurations		↔			↔		↔	↔		↔	↔	↔
Traffic Vol, veh/h	18	34	15	12	10	49	11	466	16	65	504	18
Future Vol, veh/h	18	34	15	12	10	49	11	466	16	65	504	18
Conflicting Peds, #/hr	200	0	200	200	0	200	200	0	200	200	0	200
Sign Control	Stop	Stop	Stop	Stop	Stop	Stop	Free	Free	Free	Free	Free	Free
RT Channelized	-	-	None	-	-	None	-	-	None	-	-	None
Storage Length	-	-	-	-	-	-	130	-	-	85	-	-
Veh in Median Storage, #	-	0	-	-	0	-	-	0	-	-	0	-
Grade, %	-	0	-	-	0	-	-	0	-	-	0	-
Peak Hour Factor	92	92	92	92	92	92	92	92	92	92	92	92
Heavy Vehicles, %	2	2	2	2	2	2	2	2	2	2	2	2
Mvmt Flow	20	37	16	13	11	53	12	507	17	71	548	20

Major/Minor	Minor2		Minor1		Major1		Major2					
Conflicting Flow All	1382	1647	684	1318	1648	662	767	0	0	724	0	0
Stage 1	899	899	-	739	739	-	-	-	-	-	-	-
Stage 2	483	748	-	579	909	-	-	-	-	-	-	-
Critical Hdwy	6.99	6.54	7.14	6.99	6.54	6.94	5.34	-	-	4.14	-	-
Critical Hdwy Stg 1	7.34	5.54	-	6.54	5.54	-	-	-	-	-	-	-
Critical Hdwy Stg 2	6.54	5.54	-	6.74	5.54	-	-	-	-	-	-	-
Follow-up Hdwy	3.67	4.02	3.92	3.67	4.02	3.32	3.12	-	-	2.22	-	-
Pot Cap-1 Maneuver	215	151	655	241	151	404	786	-	-	874	-	-
Stage 1	472	532	-	365	422	-	-	-	-	-	-	-
Stage 2	517	418	-	834	525	-	-	-	-	-	-	-
Platoon blocked, %	1	1	1	1	1	1	-	-	-	-	-	-
Mov Cap-1 Maneuver	101	93	455	102	93	281	655	-	-	728	-	-
Mov Cap-2 Maneuver	101	93	-	102	93	-	-	-	-	-	-	-
Stage 1	386	400	-	299	345	-	-	-	-	-	-	-
Stage 2	332	342	-	549	395	-	-	-	-	-	-	-

Approach	EB		WB		NB		SB	
HCM Control Delay, s	77.9		39.9		0.2		1.2	
HCM LOS	F		E					

Minor Lane/Major Mvmt	NBL	NBT	NBR	EBLn1	WBLn1	SBL	SBT	SBR
Capacity (veh/h)	655	-	-	116	178	728	-	-
HCM Lane V/C Ratio	0.018	-	-	0.628	0.434	0.097	-	-
HCM Control Delay (s)	10.6	-	-	77.9	39.9	10.5	-	-
HCM Lane LOS	B	-	-	F	E	B	-	-
HCM 95th %tile Q(veh)	0.1	-	-	3.2	2	0.3	-	-

**Intersection**

Intersection Delay, s/veh	7.6
Intersection LOS	A

Movement	EBL	EBT	EBR	WBL	WBT	WBR	NBL	NBT	NBR	SBL	SBT	SBR
Lane Configurations		↕			↕			↕			↕	
Traffic Vol, veh/h	11	75	22	5	47	2	22	12	6	2	12	10
Future Vol, veh/h	11	75	22	5	47	2	22	12	6	2	12	10
Peak Hour Factor	0.92	0.92	0.92	0.92	0.92	0.92	0.92	0.92	0.92	0.92	0.92	0.92
Heavy Vehicles, %	2	2	2	2	2	2	2	2	2	2	2	2
Mvmt Flow	12	82	24	5	51	2	24	13	7	2	13	11
Number of Lanes	0	1	0	0	1	0	0	1	0	0	1	0

Approach	EB	WB	NB	SB
Opposing Approach	WB	EB	SB	NB
Opposing Lanes	1	1	1	1
Conflicting Approach Left	SB	NB	EB	WB
Conflicting Lanes Left	1	1	1	1
Conflicting Approach Right	NB	SB	WB	EB
Conflicting Lanes Right	1	1	1	1
HCM Control Delay	7.7	7.5	7.6	7.3
HCM LOS	A	A	A	A

Lane	NBLn1	EBLn1	WBLn1	SBLn1
Vol Left, %	55%	10%	9%	8%
Vol Thru, %	30%	69%	87%	50%
Vol Right, %	15%	20%	4%	42%
Sign Control	Stop	Stop	Stop	Stop
Traffic Vol by Lane	40	108	54	24
LT Vol	22	11	5	2
Through Vol	12	75	47	12
RT Vol	6	22	2	10
Lane Flow Rate	43	117	59	26
Geometry Grp	1	1	1	1
Degree of Util (X)	0.052	0.13	0.068	0.029
Departure Headway (Hd)	4.277	3.998	4.141	4.037
Convergence, Y/N	Yes	Yes	Yes	Yes
Cap	826	891	858	872
Service Time	2.363	2.049	2.201	2.13
HCM Lane V/C Ratio	0.052	0.131	0.069	0.03
HCM Control Delay	7.6	7.7	7.5	7.3
HCM Lane LOS	A	A	A	A
HCM 95th-tile Q	0.2	0.4	0.2	0.1

Movement	EBL	EBT	EBR	WBL	WBT	WBR	NBL	NBT	NBR	SBL	SBT	SBR
Lane Configurations												
Traffic Volume (veh/h)	36	32	27	3	13	18	12	355	35	20	297	40
Future Volume (veh/h)	36	32	27	3	13	18	12	355	35	20	297	40
Number	3	8	18	7	4	14	1	6	16	5	2	12
Initial Q (Qb), veh	0	0	0	0	0	0	0	0	0	0	0	0
Ped-Bike Adj(A_pbT)	0.81		0.79	0.81		0.79	0.89		0.82	0.92		0.82
Parking Bus, Adj	1.00	1.00	0.90	1.00	1.00	1.00	1.00	1.00	1.00	1.00	1.00	1.00
Adj Sat Flow, veh/h/ln	1863	1863	1863	1900	1863	1900	1863	1863	1900	1863	1863	1900
Adj Flow Rate, veh/h	39	35	29	3	14	20	13	386	38	22	323	43
Adj No. of Lanes	1	1	1	0	1	0	1	2	0	1	2	0
Peak Hour Factor	0.92	0.92	0.92	0.92	0.92	0.92	0.92	0.92	0.92	0.92	0.92	0.92
Percent Heavy Veh, %	2	2	2	2	2	2	2	2	2	2	2	2
Cap, veh/h	444	535	324	75	182	226	606	1723	167	538	1654	215
Arrive On Green	0.29	0.29	0.29	0.29	0.29	0.29	0.54	0.54	0.54	1.00	1.00	1.00
Sat Flow, veh/h	1105	1863	1128	37	631	786	899	3186	310	878	3057	398
Grp Volume(v), veh/h	39	35	29	37	0	0	13	212	212	22	184	182
Grp Sat Flow(s),veh/h/ln	1105	1863	1128	1454	0	0	899	1770	1726	878	1770	1686
Q Serve(g_s), s	0.1	0.8	1.1	0.0	0.0	0.0	0.4	3.8	3.9	0.2	0.0	0.0
Cycle Q Clear(g_c), s	1.2	0.8	1.1	1.1	0.0	0.0	0.4	3.8	3.9	4.0	0.0	0.0
Prop In Lane	1.00		1.00	0.08		0.54	1.00		0.18	1.00		0.24
Lane Grp Cap(c), veh/h	444	535	324	483	0	0	606	957	933	538	957	912
V/C Ratio(X)	0.09	0.07	0.09	0.08	0.00	0.00	0.02	0.22	0.23	0.04	0.19	0.20
Avail Cap(c_a), veh/h	564	739	447	637	0	0	606	957	933	538	957	912
HCM Platoon Ratio	1.00	1.00	1.00	1.00	1.00	1.00	1.00	1.00	1.00	2.00	2.00	2.00
Upstream Filter(I)	1.00	1.00	1.00	1.00	0.00	0.00	1.00	1.00	1.00	1.00	1.00	1.00
Uniform Delay (d), s/veh	15.7	15.5	15.6	15.6	0.0	0.0	6.4	7.2	7.2	0.2	0.0	0.0
Incr Delay (d2), s/veh	0.0	0.0	0.0	0.0	0.0	0.0	0.1	0.5	0.6	0.1	0.4	0.5
Initial Q Delay(d3),s/veh	0.0	0.0	0.0	0.0	0.0	0.0	0.0	0.0	0.0	0.0	0.0	0.0
%ile BackOfQ(50%),veh/ln	0.5	0.4	0.4	0.4	0.0	0.0	0.1	2.0	2.0	0.1	0.1	0.1
LnGrp Delay(d),s/veh	15.7	15.5	15.7	15.6	0.0	0.0	6.5	7.7	7.8	0.4	0.4	0.5
LnGrp LOS	B	B	B	B			A	A	A	A	A	A
Approach Vol, veh/h		103			37			437			388	
Approach Delay, s/veh		15.6			15.6			7.7			0.5	
Approach LOS		B			B			A			A	
Timer	1	2	3	4	5	6	7	8				
Assigned Phs		2		4		6		8				
Phs Duration (G+Y+Rc), s		37.6		22.4		37.6		22.4				
Change Period (Y+Rc), s		5.1		* 5.2		5.1		* 5.2				
Max Green Setting (Gmax), s		25.9		* 24		25.9		* 24				
Max Q Clear Time (g_c+I1), s		6.0		3.1		5.9		3.2				
Green Ext Time (p_c), s		0.3		0.4		0.3		0.4				
<b>Intersection Summary</b>												
HCM 2010 Ctrl Delay			5.9									
HCM 2010 LOS			A									
<b>Notes</b>												

17: Scottsdale Road & 2nd Street

02/26/2019

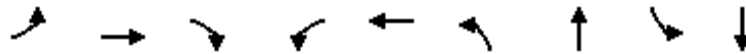

Lane Group	EBL	EBT	EBR	WBL	WBT	NBL	NBT	SBL	SBT
Lane Configurations	↘	↑	↗		↔	↘	↕	↘	↕
Traffic Volume (vph)	36	32	27	3	13	12	355	20	297
Future Volume (vph)	36	32	27	3	13	12	355	20	297
Turn Type	Perm	NA	Perm	Perm	NA	Perm	NA	Perm	NA
Protected Phases		8			4		6		2
Permitted Phases	8		8	4		6		2	
Detector Phase	8	8	8	4	4	6	6	2	2
Switch Phase									
Minimum Initial (s)	6.0	6.0	6.0	6.0	6.0	10.0	10.0	10.0	10.0
Minimum Split (s)	25.2	25.2	25.2	25.2	25.2	26.0	26.0	26.0	26.0
Total Split (s)	29.0	29.0	29.0	29.0	29.0	31.0	31.0	31.0	31.0
Total Split (%)	48.3%	48.3%	48.3%	48.3%	48.3%	51.7%	51.7%	51.7%	51.7%
Yellow Time (s)	3.0	3.0	3.0	3.0	3.0	3.0	3.0	3.0	3.0
All-Red Time (s)	2.2	2.2	2.2	2.2	2.2	2.1	2.1	2.1	2.1
Lost Time Adjust (s)	0.0	0.0	0.0		0.0	0.0	0.0	0.0	0.0
Total Lost Time (s)	5.2	5.2	5.2		5.2	5.1	5.1	5.1	5.1
Lead/Lag									
Lead-Lag Optimize?									
Recall Mode	None	None	None	None	None	C-Min	C-Min	C-Min	C-Min
Act Effct Green (s)	7.5	7.5	7.5		7.3	48.8	48.8	48.8	48.8
Actuated g/C Ratio	0.12	0.12	0.12		0.12	0.81	0.81	0.81	0.81
v/c Ratio	0.29	0.17	0.16		0.19	0.02	0.15	0.03	0.13
Control Delay	28.7	24.5	9.3		16.8	3.4	2.6	2.6	1.8
Queue Delay	0.0	0.0	0.0		0.0	0.0	0.0	0.0	0.0
Total Delay	28.7	24.5	9.3		16.8	3.4	2.6	2.6	1.8
LOS	C	C	A		B	A	A	A	A
Approach Delay		21.8			16.8		2.7		1.9
Approach LOS		C			B		A		A

Intersection Summary

Cycle Length: 60  
 Actuated Cycle Length: 60  
 Offset: 0 (0%), Referenced to phase 2:SBTL and 6:NBTL, Start of 1st Green  
 Natural Cycle: 55  
 Control Type: Actuated-Coordinated  
 Maximum v/c Ratio: 0.29  
 Intersection Signal Delay: 4.9  
 Intersection Capacity Utilization 62.9%  
 Analysis Period (min) 15

Intersection LOS: A  
 ICU Level of Service B

Splits and Phases: 17: Scottsdale Road & 2nd Street

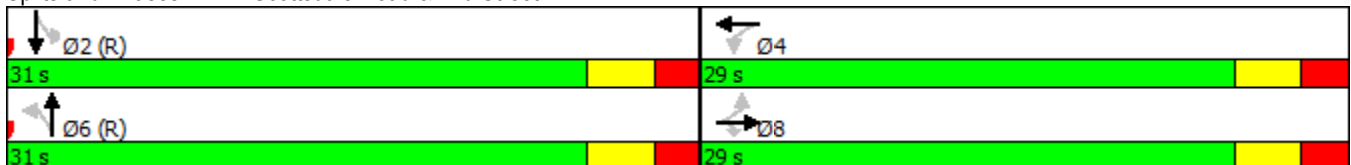

**Intersection**

Int Delay, s/veh 1.9

Movement	SET	SER	NWL	NWT	NEL	NER
Lane Configurations	↑↑↑		↘	↑↑	↘	↗
Traffic Vol, veh/h	413	69	11	392	84	25
Future Vol, veh/h	413	69	11	392	84	25
Conflicting Peds, #/hr	0	8	8	0	2	0
Sign Control	Free	Free	Free	Free	Stop	Stop
RT Channelized	-	None	-	None	-	None
Storage Length	-	-	70	-	0	0
Veh in Median Storage, #	0	-	-	0	0	-
Grade, %	0	-	-	0	0	-
Peak Hour Factor	92	92	92	92	92	92
Heavy Vehicles, %	2	2	2	2	2	2
Mvmt Flow	449	75	12	426	91	27

Major/Minor	Major1	Major2	Minor1
Conflicting Flow All	0	0	532
Stage 1	-	-	494
Stage 2	-	-	239
Critical Hdwy	-	5.34	6.29
Critical Hdwy Stg 1	-	-	6.64
Critical Hdwy Stg 2	-	-	5.84
Follow-up Hdwy	-	3.12	3.67
Pot Cap-1 Maneuver	-	654	387
Stage 1	-	-	502
Stage 2	-	-	750
Platoon blocked, %	-	-	-
Mov Cap-1 Maneuver	-	654	377
Mov Cap-2 Maneuver	-	-	377
Stage 1	-	-	499
Stage 2	-	-	735

Approach	SE	NW	NE
HCM Control Delay, s	0	0.3	16.1
HCM LOS			C

Minor Lane/Major Mvmt	NELn1	NELn2	NWL	NWT	SET	SER
Capacity (veh/h)	377	616	654	-	-	-
HCM Lane V/C Ratio	0.242	0.044	0.018	-	-	-
HCM Control Delay (s)	17.6	11.1	10.6	-	-	-
HCM Lane LOS	C	B	B	-	-	-
HCM 95th %tile Q(veh)	0.9	0.1	0.1	-	-	-

**Intersection**





















Int Delay, s/veh 1.7

Movement	EBL	EBT	EBR	WBL	WBT	WBR	NBL	NBT	NBR	SBL	SBT	SBR
Lane Configurations	↖ ↑↑↑			↖ ↑↑				↔		↖ ↑		
Traffic Vol, veh/h	12	411	15	5	356	51	38	4	9	36	0	9
Future Vol, veh/h	12	411	15	5	356	51	38	4	9	36	0	9
Conflicting Peds, #/hr	0	0	3	3	0	0	5	0	2	2	0	5
Sign Control	Free	Free	Free	Free	Free	Free	Stop	Stop	Stop	Stop	Stop	Stop
RT Channelized	-	-	None	-	-	None	-	-	None	-	-	None
Storage Length	100	-	-	70	-	-	-	-	-	55	-	-
Veh in Median Storage, #	-	0	-	-	0	-	-	0	-	-	0	-
Grade, %	-	0	-	-	0	-	-	0	-	-	0	-
Peak Hour Factor	92	92	92	92	92	92	92	92	92	92	92	92
Heavy Vehicles, %	2	2	2	2	2	2	2	2	2	2	2	2
Mvmt Flow	13	447	16	5	387	55	41	4	10	39	0	10

Major/Minor	Major1	Major2	Minor1	Minor2
Conflicting Flow All	442	0	0	466
Stage 1	-	-	-	-
Stage 2	-	-	-	-
Critical Hdwy	4.14	-	-	5.34
Critical Hdwy Stg 1	-	-	-	-
Critical Hdwy Stg 2	-	-	-	-
Follow-up Hdwy	2.22	-	-	3.12
Pot Cap-1 Maneuver	1114	-	-	703
Stage 1	-	-	-	-
Stage 2	-	-	-	-
Platoon blocked, %	-	-	-	-
Mov Cap-1 Maneuver	1109	-	-	702
Mov Cap-2 Maneuver	-	-	-	-
Stage 1	-	-	-	-
Stage 2	-	-	-	-

Approach	EB	WB	NB	SB
HCM Control Delay, s	0.2	0.1	16.7	14.6
HCM LOS			C	B

Minor Lane/Major Mvmt	NBLn1	EBL	EBT	EBR	WBL	WBT	WBR	SBLn1	SBLn2
Capacity (veh/h)	364	1109	-	-	702	-	-	371	774
HCM Lane V/C Ratio	0.152	0.012	-	-	0.008	-	-	0.105	0.013
HCM Control Delay (s)	16.7	8.3	-	-	10.2	-	-	15.8	9.7
HCM Lane LOS	C	A	-	-	B	-	-	C	A
HCM 95th %tile Q(veh)	0.5	0	-	-	0	-	-	0.4	0

												
Movement	EBL	EBT	EBR	WBL	WBT	WBR	NBL	NBT	NBR	SBL	SBT	SBR
Lane Configurations												
Traffic Volume (veh/h)	12	6	9	276	15	9	46	404	20	34	423	25
Future Volume (veh/h)	12	6	9	276	15	9	46	404	20	34	423	25
Number	3	8	18	7	4	14	1	6	16	5	2	12
Initial Q (Qb), veh	0	0	0	0	0	0	0	0	0	0	0	0
Ped-Bike Adj(A_pbT)	1.00		0.94	1.00		1.00	1.00		1.00	1.00		1.00
Parking Bus, Adj	1.00	1.00	1.00	1.00	1.00	1.00	1.00	1.00	1.00	1.00	1.00	1.00
Adj Sat Flow, veh/h/ln	1863	1863	1900	1863	1863	1900	1863	1863	1900	1863	1863	1900
Adj Flow Rate, veh/h	13	7	10	321	0	0	50	439	22	37	460	27
Adj No. of Lanes	1	1	0	2	1	0	1	2	0	1	3	0
Peak Hour Factor	0.92	0.92	0.92	0.92	0.92	0.92	0.92	0.92	0.92	0.92	0.92	0.92
Percent Heavy Veh, %	2	2	2	2	2	2	2	2	2	2	2	2
Cap, veh/h	95	36	51	479	251	0	651	2355	118	653	3375	196
Arrive On Green	0.05	0.05	0.05	0.13	0.00	0.00	0.69	0.69	0.69	0.69	0.69	0.69
Sat Flow, veh/h	1774	670	957	3548	1863	0	904	3430	171	926	4916	286
Grp Volume(v), veh/h	13	0	17	321	0	0	50	226	235	37	316	171
Grp Sat Flow(s),veh/h/ln	1774	0	1626	1774	1863	0	904	1770	1832	926	1695	1812
Q Serve(g_s), s	0.8	0.0	1.2	10.3	0.0	0.0	2.4	5.5	5.5	1.8	3.9	3.9
Cycle Q Clear(g_c), s	0.8	0.0	1.2	10.3	0.0	0.0	6.3	5.5	5.5	7.3	3.9	3.9
Prop In Lane	1.00		0.59	1.00		0.00	1.00		0.09	1.00		0.16
Lane Grp Cap(c), veh/h	95	0	87	479	251	0	651	1215	1258	653	2328	1244
V/C Ratio(X)	0.14	0.00	0.20	0.67	0.00	0.00	0.08	0.19	0.19	0.06	0.14	0.14
Avail Cap(c_a), veh/h	238	0	218	1215	638	0	651	1215	1258	653	2328	1244
HCM Platoon Ratio	1.00	1.00	1.00	1.00	1.00	1.00	1.00	1.00	1.00	1.00	1.00	1.00
Upstream Filter(I)	1.00	0.00	1.00	1.00	0.00	0.00	1.00	1.00	1.00	1.00	1.00	1.00
Uniform Delay (d), s/veh	54.2	0.0	54.3	49.4	0.0	0.0	7.6	6.8	6.8	8.1	6.5	6.5
Incr Delay (d2), s/veh	0.2	0.0	0.4	0.6	0.0	0.0	0.2	0.3	0.3	0.2	0.1	0.2
Initial Q Delay(d3),s/veh	0.0	0.0	0.0	0.0	0.0	0.0	0.0	0.0	0.0	0.0	0.0	0.0
%ile BackOfQ(50%),veh/ln	0.4	0.0	0.5	5.1	0.0	0.0	0.6	2.8	2.9	0.5	1.8	2.0
LnGrp Delay(d),s/veh	54.4	0.0	54.7	50.0	0.0	0.0	7.8	7.1	7.1	8.2	6.6	6.7
LnGrp LOS	D		D	D			A	A	A	A	A	A
Approach Vol, veh/h		30			321			511			524	
Approach Delay, s/veh		54.6			50.0			7.2			6.8	
Approach LOS		D			D			A			A	
Timer	1	2	3	4	5	6	7	8				
Assigned Phs		2		4		6		8				
Phs Duration (G+Y+Rc), s		87.6		21.1		87.6		11.3				
Change Period (Y+Rc), s		* 5.2		* 4.9		* 5.2		4.9				
Max Green Setting (Gmax), s		* 48		* 41		* 48		16.1				
Max Q Clear Time (g_c+I1), s		9.3		12.3		8.3		3.2				
Green Ext Time (p_c), s		1.7		0.6		1.7		0.0				
<b>Intersection Summary</b>												
HCM 2010 Ctrl Delay			18.0									
HCM 2010 LOS			B									
<b>Notes</b>												

21: Goldwater Boulevard & Driveway/Scottsdale Road

02/26/2019

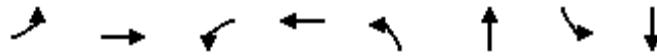

Lane Group	EBL	EBT	WBL	WBT	NBL	NBT	SBL	SBT
Lane Configurations								
Traffic Volume (vph)	12	6	276	15	46	404	34	423
Future Volume (vph)	12	6	276	15	46	404	34	423
Turn Type	Split	NA	Split	NA	Perm	NA	Perm	NA
Protected Phases	8	8	4	4		6		2
Permitted Phases					6		2	
Detector Phase	8	8	4	4	6	6	2	2
Switch Phase								
Minimum Initial (s)	7.0	7.0	7.0	7.0	10.0	10.0	10.0	10.0
Minimum Split (s)	13.0	13.0	13.0	13.0	16.0	16.0	16.0	16.0
Total Split (s)	21.0	21.0	46.0	46.0	53.0	53.0	53.0	53.0
Total Split (%)	17.5%	17.5%	38.3%	38.3%	44.2%	44.2%	44.2%	44.2%
Yellow Time (s)	3.3	3.3	3.3	3.3	4.0	4.0	4.0	4.0
All-Red Time (s)	1.6	1.6	1.6	1.6	1.2	1.2	1.2	1.2
Lost Time Adjust (s)	0.0	0.0	0.0	0.0	0.0	0.0	0.0	0.0
Total Lost Time (s)	4.9	4.9	4.9	4.9	5.2	5.2	5.2	5.2
Lead/Lag	Lead	Lead	Lag	Lag				
Lead-Lag Optimize?								
Recall Mode	None	None	None	None	C-Max	C-Max	C-Max	C-Max
Act Effct Green (s)	8.8	8.8	18.0	18.0	83.0	83.0	83.0	83.0
Actuated g/C Ratio	0.07	0.07	0.15	0.15	0.69	0.69	0.69	0.69
v/c Ratio	0.10	0.14	0.65	0.65	0.08	0.19	0.06	0.14
Control Delay	51.4	52.6	55.8	54.9	9.9	7.8	7.3	5.2
Queue Delay	0.0	0.0	0.0	0.0	0.0	0.0	0.0	0.0
Total Delay	51.4	52.6	55.8	54.9	9.9	7.8	7.3	5.2
LOS	D	D	E	D	A	A	A	A
Approach Delay		52.1		55.4		8.0		5.4
Approach LOS		D		E		A		A

Intersection Summary

Cycle Length: 120  
 Actuated Cycle Length: 120  
 Offset: 103 (86%), Referenced to phase 2:SBTL and 6:NBTL, Start of 1st Green  
 Natural Cycle: 45  
 Control Type: Actuated-Coordinated  
 Maximum v/c Ratio: 0.65  
 Intersection Signal Delay: 19.1  
 Intersection Capacity Utilization 58.0%  
 Analysis Period (min) 15

Intersection LOS: B  
 ICU Level of Service B

Splits and Phases: 21: Goldwater Boulevard & Driveway/Scottsdale Road

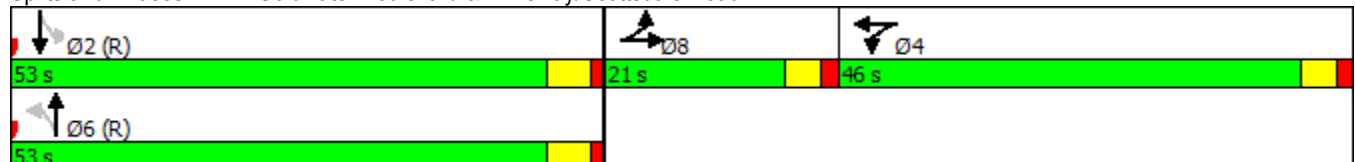

**Intersection**

Int Delay, s/veh 0.1

Movement	EBL	EBT	WBT	WBR	SBL	SBR
Lane Configurations		↑↑↑	↑↑			↑
Traffic Vol, veh/h	0	456	412	12	0	5
Future Vol, veh/h	0	456	412	12	0	5
Conflicting Peds, #/hr	0	0	0	0	0	0
Sign Control	Free	Free	Free	Free	Stop	Stop
RT Channelized	-	None	-	None	-	None
Storage Length	-	-	-	-	-	0
Veh in Median Storage, #	-	0	0	-	0	-
Grade, %	-	0	0	-	0	-
Peak Hour Factor	92	92	92	92	92	92
Heavy Vehicles, %	2	2	2	2	2	2
Mvmt Flow	0	496	448	13	0	5

**Major/Minor**

	Major1	Major2	Minor2
Conflicting Flow All	-	0	-
Stage 1	-	-	-
Stage 2	-	-	-
Critical Hdwy	-	-	-
Critical Hdwy Stg 1	-	-	-
Critical Hdwy Stg 2	-	-	-
Follow-up Hdwy	-	-	-
Pot Cap-1 Maneuver	0	-	-
Stage 1	0	-	-
Stage 2	0	-	-
Platoon blocked, %	-	-	-
Mov Cap-1 Maneuver	-	-	-
Mov Cap-2 Maneuver	-	-	-
Stage 1	-	-	-
Stage 2	-	-	-

**Approach**

	EB	WB	SB
HCM Control Delay, s	0	0	9.7
HCM LOS			A



















**Minor Lane/Major Mvmt**

	EBT	WBT	WBR	SBLn1
Capacity (veh/h)	-	-	-	772
HCM Lane V/C Ratio	-	-	-	0.007
HCM Control Delay (s)	-	-	-	9.7
HCM Lane LOS	-	-	-	A
HCM 95th %tile Q(veh)	-	-	-	0

Intersection						
Int Delay, s/veh	1.4					
Movement	EBT	EBR	WBL	WBT	NBL	NBR
Lane Configurations						
Traffic Vol, veh/h	91	9	6	39	5	16
Future Vol, veh/h	91	9	6	39	5	16
Conflicting Peds, #/hr	0	0	0	0	0	0
Sign Control	Free	Free	Free	Free	Stop	Stop
RT Channelized	-	None	-	None	-	None
Storage Length	-	-	-	-	0	-
Veh in Median Storage, #	0	-	-	0	0	-
Grade, %	0	-	-	0	0	-
Peak Hour Factor	92	92	92	92	92	92
Heavy Vehicles, %	2	2	2	2	2	2
Mvmt Flow	99	10	7	42	5	17
Major/Minor	Major1	Major2	Minor1			
Conflicting Flow All	0	0	109	0	159	104
Stage 1	-	-	-	-	104	-
Stage 2	-	-	-	-	55	-
Critical Hdwy	-	-	4.12	-	6.42	6.22
Critical Hdwy Stg 1	-	-	-	-	5.42	-
Critical Hdwy Stg 2	-	-	-	-	5.42	-
Follow-up Hdwy	-	-	2.218	-	3.518	3.318
Pot Cap-1 Maneuver	-	-	1481	-	832	951
Stage 1	-	-	-	-	920	-
Stage 2	-	-	-	-	968	-
Platoon blocked, %	-	-	-	-	-	-
Mov Cap-1 Maneuver	-	-	1481	-	828	951
Mov Cap-2 Maneuver	-	-	-	-	828	-
Stage 1	-	-	-	-	920	-
Stage 2	-	-	-	-	963	-
Approach	EB	WB	NB			
HCM Control Delay, s	0	1	9			
HCM LOS				A		
Minor Lane/Major Mvmt	NBLn1	EBT	EBR	WBL	WBT	
Capacity (veh/h)	919	-	-	1481	-	
HCM Lane V/C Ratio	0.025	-	-	0.004	-	
HCM Control Delay (s)	9	-	-	7.4	0	
HCM Lane LOS	A	-	-	A	A	
HCM 95th %tile Q(veh)	0.1	-	-	0	-	

Intersection						
Int Delay, s/veh	4.6					
Movement	EBL	EBR	NBL	NBT	SBT	SBR
Lane Configurations						
Traffic Vol, veh/h	16	3	5	6	2	12
Future Vol, veh/h	16	3	5	6	2	12
Conflicting Peds, #/hr	0	0	0	0	0	0
Sign Control	Stop	Stop	Free	Free	Free	Free
RT Channelized	-	None	-	None	-	None
Storage Length	0	-	-	-	-	-
Veh in Median Storage, #	0	-	-	0	0	-
Grade, %	0	-	-	0	0	-
Peak Hour Factor	92	92	92	92	92	92
Heavy Vehicles, %	2	2	2	2	2	2
Mvmt Flow	17	3	5	7	2	13
Major/Minor	Minor2	Major1		Major2		
Conflicting Flow All	26	9	15	0	0	
Stage 1	9	-	-	-	-	
Stage 2	17	-	-	-	-	
Critical Hdwy	6.42	6.22	4.12	-	-	
Critical Hdwy Stg 1	5.42	-	-	-	-	
Critical Hdwy Stg 2	5.42	-	-	-	-	
Follow-up Hdwy	3.518	3.318	2.218	-	-	
Pot Cap-1 Maneuver	989	1073	1603	-	-	
Stage 1	1014	-	-	-	-	
Stage 2	1006	-	-	-	-	
Platoon blocked, %				-	-	
Mov Cap-1 Maneuver	986	1073	1603	-	-	
Mov Cap-2 Maneuver	986	-	-	-	-	
Stage 1	1014	-	-	-	-	
Stage 2	1003	-	-	-	-	
Approach	EB	NB		SB		
HCM Control Delay, s	8.7	3.3		0		
HCM LOS	A					
Minor Lane/Major Mvmt	NBL	NBT	EBLn1	SBT	SBR	
Capacity (veh/h)	1603	-	999	-	-	
HCM Lane V/C Ratio	0.003	-	0.021	-	-	
HCM Control Delay (s)	7.3	0	8.7	-	-	
HCM Lane LOS	A	A	A	-	-	
HCM 95th %tile Q(veh)	0	-	0.1	-	-	

Intersection						
Int Delay, s/veh	1.8					
Movement	EBT	EBR	WBL	WBT	NBL	NBR
Lane Configurations						
Traffic Vol, veh/h	83	0	0	39	15	16
Future Vol, veh/h	83	0	0	39	15	16
Conflicting Peds, #/hr	0	0	0	0	0	0
Sign Control	Free	Free	Free	Free	Stop	Stop
RT Channelized	-	None	-	None	-	None
Storage Length	-	-	-	-	0	-
Veh in Median Storage, #	0	-	-	0	0	-
Grade, %	0	-	-	0	0	-
Peak Hour Factor	92	92	92	92	92	92
Heavy Vehicles, %	2	2	2	2	2	2
Mvmt Flow	90	0	0	42	16	17
Major/Minor	Major1	Major2	Minor1			
Conflicting Flow All	0	0	90	0	132	90
Stage 1	-	-	-	-	90	-
Stage 2	-	-	-	-	42	-
Critical Hdwy	-	-	4.12	-	6.42	6.22
Critical Hdwy Stg 1	-	-	-	-	5.42	-
Critical Hdwy Stg 2	-	-	-	-	5.42	-
Follow-up Hdwy	-	-	2.218	-	3.518	3.318
Pot Cap-1 Maneuver	-	-	1505	-	862	968
Stage 1	-	-	-	-	934	-
Stage 2	-	-	-	-	980	-
Platoon blocked, %	-	-	-	-	-	-
Mov Cap-1 Maneuver	-	-	1505	-	862	968
Mov Cap-2 Maneuver	-	-	-	-	862	-
Stage 1	-	-	-	-	934	-
Stage 2	-	-	-	-	980	-
Approach	EB	WB	NB			
HCM Control Delay, s	0	0	9.1			
HCM LOS						A
Minor Lane/Major Mvmt	NBLn1	EBT	EBR	WBL	WBT	
Capacity (veh/h)	914	-	-	1505	-	
HCM Lane V/C Ratio	0.037	-	-	-	-	
HCM Control Delay (s)	9.1	-	-	0	-	
HCM Lane LOS	A	-	-	A	-	
HCM 95th %tile Q(veh)	0.1	-	-	0	-	

												
Movement	EBL	EBT	EBR	WBL	WBT	WBR	NBL	NBT	NBR	SBL	SBT	SBR
Lane Configurations												
Traffic Volume (veh/h)	12	29	25	21	39	96	32	384	30	88	911	23
Future Volume (veh/h)	12	29	25	21	39	96	32	384	30	88	911	23
Number	3	8	18	7	4	14	1	6	16	5	2	12
Initial Q (Qb), veh	0	0	0	0	0	0	0	0	0	0	0	0
Ped-Bike Adj(A_pbT)	0.84		0.75	0.79		0.75	0.97		0.87	0.97		0.88
Parking Bus, Adj	1.00	1.00	1.00	1.00	1.00	1.00	1.00	1.00	1.00	1.00	1.00	1.00
Adj Sat Flow, veh/h/ln	1900	1863	1900	1900	1863	1900	1863	1863	1900	1863	1863	1900
Adj Flow Rate, veh/h	13	32	27	23	42	104	35	417	33	96	990	25
Adj No. of Lanes	0	1	0	0	1	0	1	2	0	1	3	0
Peak Hour Factor	0.92	0.92	0.92	0.92	0.92	0.92	0.92	0.92	0.92	0.92	0.92	0.92
Percent Heavy Veh, %	2	2	2	2	2	2	2	2	2	2	2	2
Cap, veh/h	80	178	134	60	97	196	422	2218	174	628	3430	86
Arrive On Green	0.24	0.24	0.24	0.24	0.24	0.24	0.68	0.68	0.68	1.00	1.00	1.00
Sat Flow, veh/h	185	738	554	107	401	813	536	3285	258	906	5081	128
Grp Volume(v), veh/h	72	0	0	169	0	0	35	223	227	96	660	355
Grp Sat Flow(s),veh/h/ln	1477	0	0	1321	0	0	536	1770	1773	906	1695	1819
Q Serve(g_s), s	0.0	0.0	0.0	1.6	0.0	0.0	2.7	5.6	5.7	1.1	0.0	0.0
Cycle Q Clear(g_c), s	4.5	0.0	0.0	12.8	0.0	0.0	2.7	5.6	5.7	6.8	0.0	0.0
Prop In Lane	0.18		0.37	0.14		0.62	1.00		0.15	1.00		0.07
Lane Grp Cap(c), veh/h	392	0	0	353	0	0	422	1195	1197	628	2289	1228
V/C Ratio(X)	0.18	0.00	0.00	0.48	0.00	0.00	0.08	0.19	0.19	0.15	0.29	0.29
Avail Cap(c_a), veh/h	567	0	0	516	0	0	422	1195	1197	628	2289	1228
HCM Platoon Ratio	1.00	1.00	1.00	1.00	1.00	1.00	1.00	1.00	1.00	2.00	2.00	2.00
Upstream Filter(I)	1.00	0.00	0.00	1.00	0.00	0.00	1.00	1.00	1.00	1.00	1.00	1.00
Uniform Delay (d), s/veh	36.2	0.0	0.0	39.3	0.0	0.0	6.8	7.2	7.3	0.2	0.0	0.0
Incr Delay (d2), s/veh	0.1	0.0	0.0	0.4	0.0	0.0	0.4	0.3	0.4	0.5	0.3	0.6
Initial Q Delay(d3),s/veh	0.0	0.0	0.0	0.0	0.0	0.0	0.0	0.0	0.0	0.0	0.0	0.0
%ile BackOfQ(50%),veh/ln	1.9	0.0	0.0	4.9	0.0	0.0	0.4	2.8	2.9	0.3	0.1	0.2
LnGrp Delay(d),s/veh	36.3	0.0	0.0	39.7	0.0	0.0	7.2	7.6	7.6	0.8	0.3	0.6
LnGrp LOS	D			D			A	A	A	A	A	A
Approach Vol, veh/h		72			169			485			1111	
Approach Delay, s/veh		36.3			39.7			7.6			0.4	
Approach LOS		D			D			A			A	
Timer	1	2	3	4	5	6	7	8				
Assigned Phs		2		4		6		8				
Phs Duration (G+Y+Rc), s		86.2		33.8		86.2		33.8				
Change Period (Y+Rc), s		* 5.2		* 4.8		* 5.2		* 4.8				
Max Green Setting (Gmax), s		* 66		* 44		* 66		* 44				
Max Q Clear Time (g_c+I1), s		8.8		14.8		7.7		6.5				
Green Ext Time (p_c), s		1.9		1.3		1.9		1.4				
<b>Intersection Summary</b>												
HCM 2010 Ctrl Delay				7.3								
HCM 2010 LOS				A								
<b>Notes</b>												

12: Goldwater Boulevard & 2nd Street

02/26/2019

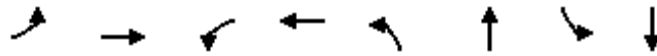

Lane Group	EBL	EBT	WBL	WBT	NBL	NBT	SBL	SBT
Lane Configurations		↕		↕	↙	↕	↙	↕↕↕
Traffic Volume (vph)	12	29	21	39	32	384	88	911
Future Volume (vph)	12	29	21	39	32	384	88	911
Turn Type	Perm	NA	Perm	NA	Perm	NA	Perm	NA
Protected Phases		8		4		6		2
Permitted Phases	8		4		6		2	
Detector Phase	8	8	4	4	6	6	2	2
Switch Phase								
Minimum Initial (s)	7.0	7.0	7.0	7.0	10.0	10.0	10.0	10.0
Minimum Split (s)	12.0	12.0	12.0	12.0	16.0	16.0	16.0	16.0
Total Split (s)	49.0	49.0	49.0	49.0	71.0	71.0	71.0	71.0
Total Split (%)	40.8%	40.8%	40.8%	40.8%	59.2%	59.2%	59.2%	59.2%
Yellow Time (s)	3.3	3.3	3.3	3.3	4.0	4.0	4.0	4.0
All-Red Time (s)	1.5	1.5	1.5	1.5	1.2	1.2	1.2	1.2
Lost Time Adjust (s)		0.0		0.0	0.0	0.0	0.0	0.0
Total Lost Time (s)		4.8		4.8	5.2	5.2	5.2	5.2
Lead/Lag								
Lead-Lag Optimize?								
Recall Mode	None	None	Ped	Ped	C-Max	C-Max	C-Max	C-Max
Act Effct Green (s)		29.0		29.0	81.0	81.0	81.0	81.0
Actuated g/C Ratio		0.24		0.24	0.68	0.68	0.68	0.68
v/c Ratio		0.19		0.44	0.12	0.20	0.21	0.30
Control Delay		25.5		25.0	14.2	10.9	2.6	1.7
Queue Delay		0.0		0.0	0.0	0.0	0.0	0.0
Total Delay		25.5		25.0	14.2	10.9	2.6	1.7
LOS		C		C	B	B	A	A
Approach Delay		25.5		25.0		11.1		1.8
Approach LOS		C		C		B		A

Intersection Summary

Cycle Length: 120  
 Actuated Cycle Length: 120  
 Offset: 113 (94%), Referenced to phase 2:SBTL and 6:NBTL, Start of Green  
 Natural Cycle: 40  
 Control Type: Actuated-Coordinated  
 Maximum v/c Ratio: 0.44  
 Intersection Signal Delay: 7.3  
 Intersection Capacity Utilization 63.5%  
 Analysis Period (min) 15  
 Intersection LOS: A  
 ICU Level of Service B

Splits and Phases: 12: Goldwater Boulevard & 2nd Street

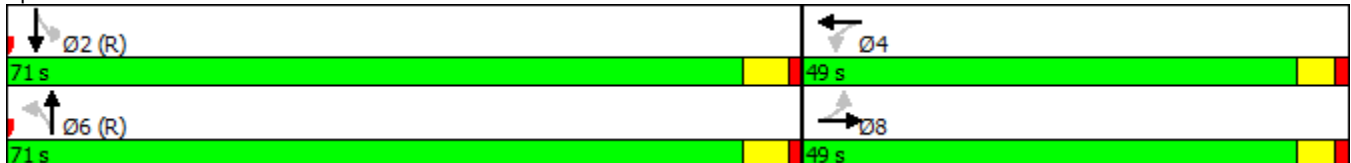

Intersection												
Int Delay, s/veh	34.7											
Movement	EBL	EBT	EBR	WBL	WBT	WBR	NBL	NBT	NBR	SBL	SBT	SBR
Lane Configurations		↕			↕		↕	↕		↕	↕	↕
Traffic Vol, veh/h	12	29	25	21	39	96	32	384	30	88	911	23
Future Vol, veh/h	12	29	25	21	39	96	32	384	30	88	911	23
Conflicting Peds, #/hr	200	0	200	200	0	200	200	0	200	200	0	200
Sign Control	Stop	Stop	Stop	Stop	Stop	Stop	Free	Free	Free	Free	Free	Free
RT Channelized	-	-	None	-	-	None	-	-	None	-	-	None
Storage Length	-	-	-	-	-	-	130	-	-	80	-	-
Veh in Median Storage, #	-	0	-	-	0	-	-	0	-	-	0	-
Grade, %	-	0	-	-	0	-	-	0	-	-	0	-
Peak Hour Factor	92	92	92	92	92	92	92	92	92	92	92	92
Heavy Vehicles, %	2	2	2	2	2	2	2	2	2	2	2	2
Mvmt Flow	13	32	27	23	42	104	35	417	33	96	990	25

Major/Minor	Minor2		Minor1		Major1		Major2					
Conflicting Flow All	1893	2114	908	1506	2110	625	1215	0	0	650	0	0
Stage 1	1394	1394	-	703	703	-	-	-	-	-	-	-
Stage 2	499	720	-	803	1407	-	-	-	-	-	-	-
Critical Hdwy	6.99	6.54	7.14	6.99	6.54	6.94	5.34	-	-	4.14	-	-
Critical Hdwy Stg 1	7.34	5.54	-	6.54	5.54	-	-	-	-	-	-	-
Critical Hdwy Stg 2	6.54	5.54	-	6.74	5.54	-	-	-	-	-	-	-
Follow-up Hdwy	3.67	4.02	3.92	3.67	4.02	3.32	3.12	-	-	2.22	-	-
Pot Cap-1 Maneuver	137	102	*716	*290	103	428	660	-	-	932	-	-
Stage 1	341	413	-	*383	438	-	-	-	-	-	-	-
Stage 2	506	430	-	*765	406	-	-	-	-	-	-	-
Platoon blocked, %	1	1	1	1	1	1	-	-	-	-	-	-
Mov Cap-1 Maneuver	23	58	*497	*95	59	297	550	-	-	777	-	-
Mov Cap-2 Maneuver	23	58	-	*95	59	-	-	-	-	-	-	-
Stage 1	266	302	-	*299	342	-	-	-	-	-	-	-
Stage 2	224	336	-	*473	297	-	-	-	-	-	-	-

Approach	EB		WB		NB		SB	
HCM Control Delay, s	275.8		250.3		0.9		0.9	
HCM LOS	F		F					

Minor Lane/Major Mvmt	NBL	NBT	NBR	EBLn1WBLn1	SBL	SBT	SBR
Capacity (veh/h)	550	-	-	62	129	777	-
HCM Lane V/C Ratio	0.063	-	-	1.157	1.314	0.123	-
HCM Control Delay (s)	12	-	-	275.8	250.3	10.3	-
HCM Lane LOS	B	-	-	F	F	B	-
HCM 95th %tile Q(veh)	0.2	-	-	5.8	10.9	0.4	-

Notes  
 ~: Volume exceeds capacity    \$: Delay exceeds 300s    +: Computation Not Defined    \*: All major volume in platoon





















**Intersection**

Intersection Delay, s/veh	8
Intersection LOS	A

Movement	EBL	EBT	EBR	WBL	WBT	WBR	NBL	NBT	NBR	SBL	SBT	SBR
Lane Configurations		↕			↕			↕			↕	
Traffic Vol, veh/h	12	80	29	8	102	3	25	25	4	7	36	21
Future Vol, veh/h	12	80	29	8	102	3	25	25	4	7	36	21
Peak Hour Factor	0.92	0.92	0.92	0.92	0.92	0.92	0.92	0.92	0.92	0.92	0.92	0.92
Heavy Vehicles, %	2	2	2	2	2	2	2	2	2	2	2	2
Mvmt Flow	13	87	32	9	111	3	27	27	4	8	39	23
Number of Lanes	0	1	0	0	1	0	0	1	0	0	1	0

Approach	EB	WB	NB	SB
Opposing Approach	WB	EB	SB	NB
Opposing Lanes	1	1	1	1
Conflicting Approach Left	SB	NB	EB	WB
Conflicting Lanes Left	1	1	1	1
Conflicting Approach Right	NB	SB	WB	EB
Conflicting Lanes Right	1	1	1	1
HCM Control Delay	8	8.1	8	7.8
HCM LOS	A	A	A	A

Lane	NBLn1	EBLn1	WBLn1	SBLn1
Vol Left, %	46%	10%	7%	11%
Vol Thru, %	46%	66%	90%	56%
Vol Right, %	7%	24%	3%	33%
Sign Control	Stop	Stop	Stop	Stop
Traffic Vol by Lane	54	121	113	64
LT Vol	25	12	8	7
Through Vol	25	80	102	36
RT Vol	4	29	3	21
Lane Flow Rate	59	132	123	70
Geometry Grp	1	1	1	1
Degree of Util (X)	0.075	0.155	0.149	0.085
Departure Headway (Hd)	4.628	4.241	4.369	4.395
Convergence, Y/N	Yes	Yes	Yes	Yes
Cap	776	848	823	817
Service Time	2.646	2.254	2.382	2.412
HCM Lane V/C Ratio	0.076	0.156	0.149	0.086
HCM Control Delay	8	8	8.1	7.8
HCM Lane LOS	A	A	A	A
HCM 95th-tile Q	0.2	0.5	0.5	0.3

												
Movement	EBL	EBT	EBR	WBL	WBT	WBR	NBL	NBT	NBR	SBL	SBT	SBR
Lane Configurations												
Traffic Volume (veh/h)	51	29	26	31	52	32	10	440	44	31	550	54
Future Volume (veh/h)	51	29	26	31	52	32	10	440	44	31	550	54
Number	3	8	18	7	4	14	1	6	16	5	2	12
Initial Q (Qb), veh	0	0	0	0	0	0	0	0	0	0	0	0
Ped-Bike Adj(A_pbT)	0.84		0.79	0.81		0.79	0.93		0.80	0.93		0.81
Parking Bus, Adj	1.00	1.00	0.90	1.00	1.00	1.00	1.00	1.00	1.00	1.00	1.00	1.00
Adj Sat Flow, veh/h/ln	1863	1863	1863	1900	1863	1900	1863	1863	1900	1863	1863	1900
Adj Flow Rate, veh/h	55	32	28	34	57	35	11	478	48	34	598	59
Adj No. of Lanes	1	1	1	0	1	0	1	2	0	1	2	0
Peak Hour Factor	0.92	0.92	0.92	0.92	0.92	0.92	0.92	0.92	0.92	0.92	0.92	0.92
Percent Heavy Veh, %	2	2	2	2	2	2	2	2	2	2	2	2
Cap, veh/h	457	538	326	154	230	118	506	1709	170	491	1716	169
Arrive On Green	0.29	0.29	0.29	0.29	0.29	0.29	0.54	0.54	0.54	1.00	1.00	1.00
Sat Flow, veh/h	1086	1863	1129	268	796	409	716	3168	315	813	3181	312
Grp Volume(v), veh/h	55	32	28	126	0	0	11	265	261	34	331	326
Grp Sat Flow(s),veh/h/ln	1086	1863	1129	1473	0	0	716	1770	1713	813	1770	1724
Q Serve(g_s), s	0.0	0.7	1.1	0.0	0.0	0.0	0.4	4.9	5.0	0.4	0.0	0.0
Cycle Q Clear(g_c), s	1.6	0.7	1.1	3.5	0.0	0.0	0.4	4.9	5.0	5.4	0.0	0.0
Prop In Lane	1.00		1.00	0.27		0.28	1.00		0.18	1.00		0.18
Lane Grp Cap(c), veh/h	457	538	326	502	0	0	506	955	924	491	955	930
V/C Ratio(X)	0.12	0.06	0.09	0.25	0.00	0.00	0.02	0.28	0.28	0.07	0.35	0.35
Avail Cap(c_a), veh/h	556	708	429	630	0	0	506	955	924	491	955	930
HCM Platoon Ratio	1.00	1.00	1.00	1.00	1.00	1.00	1.00	1.00	1.00	2.00	2.00	2.00
Upstream Filter(I)	1.00	1.00	1.00	1.00	0.00	0.00	1.00	1.00	1.00	0.98	0.98	0.98
Uniform Delay (d), s/veh	15.8	15.4	15.6	16.4	0.0	0.0	6.5	7.5	7.5	0.4	0.0	0.0
Incr Delay (d2), s/veh	0.0	0.0	0.0	0.1	0.0	0.0	0.1	0.7	0.8	0.3	1.0	1.0
Initial Q Delay(d3),s/veh	0.0	0.0	0.0	0.0	0.0	0.0	0.0	0.0	0.0	0.0	0.0	0.0
%ile BackOfQ(50%),veh/ln	0.7	0.4	0.3	1.6	0.0	0.0	0.1	2.5	2.5	0.1	0.3	0.3
LnGrp Delay(d),s/veh	15.8	15.5	15.6	16.5	0.0	0.0	6.5	8.2	8.3	0.7	1.0	1.0
LnGrp LOS	B	B	B	B			A	A	A	A	A	A
Approach Vol, veh/h		115			126			537			691	
Approach Delay, s/veh		15.7			16.5			8.2			1.0	
Approach LOS		B			B			A			A	
Timer	1	2	3	4	5	6	7	8				
Assigned Phs		2		4		6		8				
Phs Duration (G+Y+Rc), s		37.5		22.5		37.5		22.5				
Change Period (Y+Rc), s		5.1		* 5.2		5.1		* 5.2				
Max Green Setting (Gmax), s		26.9		* 23		26.9		* 23				
Max Q Clear Time (g_c+I1), s		7.4		5.5		7.0		3.6				
Green Ext Time (p_c), s		0.4		0.6		0.4		0.7				
<b>Intersection Summary</b>												
HCM 2010 Ctrl Delay			6.1									
HCM 2010 LOS			A									
<b>Notes</b>												

17: Scottsdale Road & 2nd Street

02/26/2019

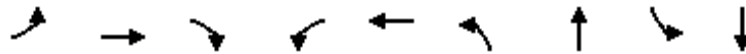

Lane Group	EBL	EBT	EBR	WBL	WBT	NBL	NBT	SBL	SBT
Lane Configurations									
Traffic Volume (vph)	51	29	26	31	52	10	440	31	550
Future Volume (vph)	51	29	26	31	52	10	440	31	550
Turn Type	Perm	NA	Perm	Perm	NA	Perm	NA	Perm	NA
Protected Phases		8			4		6		2
Permitted Phases	8		8	4		6		2	
Detector Phase	8	8	8	4	4	6	6	2	2
Switch Phase									
Minimum Initial (s)	6.0	6.0	6.0	6.0	6.0	10.0	10.0	10.0	10.0
Minimum Split (s)	25.2	25.2	25.2	25.2	25.2	26.0	26.0	26.0	26.0
Total Split (s)	28.0	28.0	28.0	28.0	28.0	32.0	32.0	32.0	32.0
Total Split (%)	46.7%	46.7%	46.7%	46.7%	46.7%	53.3%	53.3%	53.3%	53.3%
Yellow Time (s)	3.0	3.0	3.0	3.0	3.0	3.0	3.0	3.0	3.0
All-Red Time (s)	2.2	2.2	2.2	2.2	2.2	2.1	2.1	2.1	2.1
Lost Time Adjust (s)	0.0	0.0	0.0		0.0	0.0	0.0	0.0	0.0
Total Lost Time (s)	5.2	5.2	5.2		5.2	5.1	5.1	5.1	5.1
Lead/Lag									
Lead-Lag Optimize?									
Recall Mode	None	None	None	None	None	C-Min	C-Min	C-Min	C-Min
Act Effct Green (s)	8.6	8.6	8.6		8.6	44.4	44.4	44.4	44.4
Actuated g/C Ratio	0.14	0.14	0.14		0.14	0.74	0.74	0.74	0.74
v/c Ratio	0.37	0.13	0.14		0.53	0.02	0.21	0.06	0.26
Control Delay	29.3	22.2	8.1		25.4	2.3	2.0	2.9	2.5
Queue Delay	0.0	0.0	0.0		0.0	0.0	0.0	0.0	0.0
Total Delay	29.3	22.2	8.1		25.4	2.3	2.0	2.9	2.5
LOS	C	C	A		C	A	A	A	A
Approach Delay		22.1			25.4		2.0		2.5
Approach LOS		C			C		A		A

Intersection Summary

Cycle Length: 60  
 Actuated Cycle Length: 60  
 Offset: 0 (0%), Referenced to phase 2:SBTL and 6:NBTL, Start of 1st Green  
 Natural Cycle: 55  
 Control Type: Actuated-Coordinated  
 Maximum v/c Ratio: 0.53  
 Intersection Signal Delay: 5.8  
 Intersection Capacity Utilization 63.8%  
 Analysis Period (min) 15

Intersection LOS: A  
 ICU Level of Service B

Splits and Phases: 17: Scottsdale Road & 2nd Street

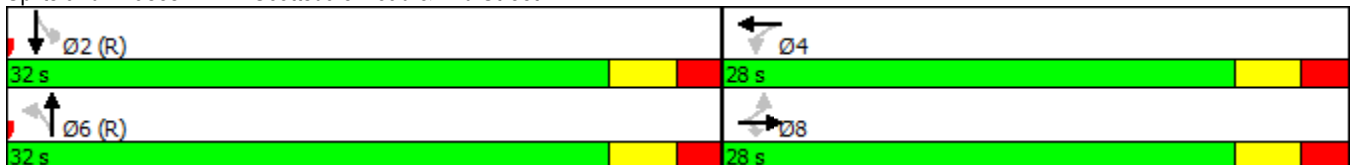

Intersection						
Int Delay, s/veh	3.2					
Movement	SET	SER	NWL	NWT	NEL	NER
Lane Configurations	↑↑↑		↘	↑↑	↘	↘
Traffic Vol, veh/h	761	191	29	344	92	19
Future Vol, veh/h	761	191	29	344	92	19
Conflicting Peds, #/hr	0	9	9	0	2	0
Sign Control	Free	Free	Free	Free	Stop	Stop
RT Channelized	-	None	-	None	-	None
Storage Length	-	-	70	-	0	0
Veh in Median Storage, #	0	-	-	0	0	-
Grade, %	0	-	-	0	0	-
Peak Hour Factor	92	92	92	92	92	92
Heavy Vehicles, %	2	2	2	2	2	2
Mvmt Flow	827	208	32	374	100	21

Major/Minor	Major1	Major2	Minor1			
Conflicting Flow All	0	0	1044	0	1192	526
Stage 1	-	-	-	-	940	-
Stage 2	-	-	-	-	252	-
Critical Hdwy	-	-	5.34	-	6.29	7.14
Critical Hdwy Stg 1	-	-	-	-	6.64	-
Critical Hdwy Stg 2	-	-	-	-	5.84	-
Follow-up Hdwy	-	-	3.12	-	3.67	3.92
Pot Cap-1 Maneuver	-	-	373	-	211	425
Stage 1	-	-	-	-	269	-
Stage 2	-	-	-	-	739	-
Platoon blocked, %	-	-	-	-	-	-
Mov Cap-1 Maneuver	-	-	373	-	191	422
Mov Cap-2 Maneuver	-	-	-	-	191	-
Stage 1	-	-	-	-	267	-
Stage 2	-	-	-	-	674	-

Approach	SE	NW	NE
HCM Control Delay, s	0	1.2	38
HCM LOS			E





















Minor Lane/Major Mvmt	NELn1	NELn2	NWL	NWT	SET	SER
Capacity (veh/h)	191	422	373	-	-	-
HCM Lane V/C Ratio	0.524	0.049	0.085	-	-	-
HCM Control Delay (s)	42.9	14	15.5	-	-	-
HCM Lane LOS	E	B	C	-	-	-
HCM 95th %tile Q(veh)	2.7	0.2	0.3	-	-	-

Intersection												
Int Delay, s/veh	2.4											
Movement	EBL	EBT	EBR	WBL	WBT	WBR	NBL	NBT	NBR	SBL	SBT	SBR
Lane Configurations	↖ ↑↑↑			↖ ↑↑			↔			↖ ↑		
Traffic Vol, veh/h	17	730	34	11	331	53	25	8	8	54	10	17
Future Vol, veh/h	17	730	34	11	331	53	25	8	8	54	10	17
Conflicting Peds, #/hr	3	0	12	12	0	3	8	0	1	1	0	8
Sign Control	Free	Free	Free	Free	Free	Free	Stop	Stop	Stop	Stop	Stop	Stop
RT Channelized	-	-	None	-	-	None	-	-	None	-	-	None
Storage Length	100	-	-	70	-	-	-	-	-	55	-	-
Veh in Median Storage, #	-	0	-	-	0	-	-	0	-	-	0	-
Grade, %	-	0	-	-	0	-	-	0	-	-	0	-
Peak Hour Factor	92	92	92	92	92	92	92	92	92	92	92	92
Heavy Vehicles, %	2	2	2	2	2	2	2	2	2	2	2	2
Mvmt Flow	18	793	37	12	360	58	27	9	9	59	11	18

Major/Minor	Major1			Major2			Minor1			Minor2		
Conflicting Flow All	420	0	0	842	0	0	1078	1305	428	776	1295	220
Stage 1	-	-	-	-	-	-	861	861	-	416	416	-
Stage 2	-	-	-	-	-	-	217	444	-	360	879	-
Critical Hdwy	4.14	-	-	5.34	-	-	6.99	6.54	7.14	6.99	6.54	6.94
Critical Hdwy Stg 1	-	-	-	-	-	-	7.34	5.54	-	6.54	5.54	-
Critical Hdwy Stg 2	-	-	-	-	-	-	6.54	5.54	-	6.74	5.54	-
Follow-up Hdwy	2.22	-	-	3.12	-	-	3.67	4.02	3.92	3.67	4.02	3.32
Pot Cap-1 Maneuver	1136	-	-	466	-	-	199	159	492	315	161	784
Stage 1	-	-	-	-	-	-	255	371	-	565	590	-
Stage 2	-	-	-	-	-	-	737	574	-	597	363	-
Platoon blocked, %	-	-	-	-	-	-	-	-	-	-	-	-
Mov Cap-1 Maneuver	1128	-	-	466	-	-	175	151	487	286	152	777
Mov Cap-2 Maneuver	-	-	-	-	-	-	175	151	-	286	152	-
Stage 1	-	-	-	-	-	-	248	361	-	555	573	-
Stage 2	-	-	-	-	-	-	683	558	-	563	354	-

Approach	EB			WB			NB			SB		
HCM Control Delay, s	0.2			0.4			29.2			19.8		
HCM LOS							D			C		

Minor Lane/Major Mvmt	NBLn1	EBL	EBT	EBR	WBL	WBT	WBR	SBLn1	SBLn2
Capacity (veh/h)	193	1128	-	-	466	-	-	286	308
HCM Lane V/C Ratio	0.231	0.016	-	-	0.026	-	-	0.205	0.095
HCM Control Delay (s)	29.2	8.2	-	-	12.9	-	-	20.8	17.9
HCM Lane LOS	D	A	-	-	B	-	-	C	C
HCM 95th %tile Q(veh)	0.9	0.1	-	-	0.1	-	-	0.8	0.3

												
Movement	EBL	EBT	EBR	WBL	WBT	WBR	NBL	NBT	NBR	SBL	SBT	SBR
Lane Configurations												
Traffic Volume (veh/h)	14	6	12	633	23	20	21	369	13	23	772	21
Future Volume (veh/h)	14	6	12	633	23	20	21	369	13	23	772	21
Number	3	8	18	7	4	14	1	6	16	5	2	12
Initial Q (Qb), veh	0	0	0	0	0	0	0	0	0	0	0	0
Ped-Bike Adj(A_pbT)	1.00		0.83	1.00		1.00	1.00		0.97	1.00		0.97
Parking Bus, Adj	1.00	1.00	1.00	1.00	1.00	1.00	1.00	1.00	1.00	1.00	1.00	1.00
Adj Sat Flow, veh/h/ln	1863	1863	1900	1863	1863	1900	1863	1863	1900	1863	1863	1900
Adj Flow Rate, veh/h	15	7	13	726	0	0	23	401	14	25	839	23
Adj No. of Lanes	1	1	0	2	1	0	1	2	0	1	3	0
Peak Hour Factor	0.92	0.92	0.92	0.92	0.92	0.92	0.92	0.92	0.92	0.92	0.92	0.92
Percent Heavy Veh, %	2	2	2	2	2	2	2	2	2	2	2	2
Cap, veh/h	102	30	55	857	450	0	374	2007	70	562	2927	80
Arrive On Green	0.06	0.06	0.06	0.24	0.00	0.00	0.58	0.58	0.58	0.58	0.58	0.58
Sat Flow, veh/h	1774	512	951	3548	1863	0	638	3485	121	964	5084	139
Grp Volume(v), veh/h	15	0	20	726	0	0	23	203	212	25	559	303
Grp Sat Flow(s),veh/h/ln	1774	0	1463	1774	1863	0	638	1770	1837	964	1695	1833
Q Serve(g_s), s	1.0	0.0	1.6	23.4	0.0	0.0	2.3	6.6	6.6	1.5	10.0	10.1
Cycle Q Clear(g_c), s	1.0	0.0	1.6	23.4	0.0	0.0	12.4	6.6	6.6	8.2	10.0	10.1
Prop In Lane	1.00		0.65	1.00		0.00	1.00		0.07	1.00		0.08
Lane Grp Cap(c), veh/h	102	0	84	857	450	0	374	1019	1058	562	1952	1055
V/C Ratio(X)	0.15	0.00	0.24	0.85	0.00	0.00	0.06	0.20	0.20	0.04	0.29	0.29
Avail Cap(c_a), veh/h	149	0	123	1600	840	0	374	1019	1058	562	1952	1055
HCM Platoon Ratio	1.00	1.00	1.00	1.00	1.00	1.00	1.00	1.00	1.00	1.00	1.00	1.00
Upstream Filter(I)	1.00	0.00	1.00	1.00	0.00	0.00	1.00	1.00	1.00	1.00	1.00	1.00
Uniform Delay (d), s/veh	53.7	0.0	54.0	43.4	0.0	0.0	16.1	12.2	12.2	14.2	12.9	12.9
Incr Delay (d2), s/veh	0.2	0.0	0.5	0.9	0.0	0.0	0.3	0.4	0.4	0.1	0.4	0.7
Initial Q Delay(d3),s/veh	0.0	0.0	0.0	0.0	0.0	0.0	0.0	0.0	0.0	0.0	0.0	0.0
%ile BackOfQ(50%),veh/ln	0.5	0.0	0.6	11.6	0.0	0.0	0.4	3.3	3.5	0.4	4.8	5.3
LnGrp Delay(d),s/veh	54.0	0.0	54.5	44.3	0.0	0.0	16.4	12.6	12.6	14.3	13.3	13.6
LnGrp LOS	D		D	D			B	B	B	B	B	B
Approach Vol, veh/h		35			726			438			887	
Approach Delay, s/veh		54.3			44.3			12.8			13.4	
Approach LOS		D			D			B			B	
Timer	1	2	3	4	5	6	7	8				
Assigned Phs		2		4		6		8				
Phs Duration (G+Y+Rc), s		74.3		33.9		74.3		11.8				
Change Period (Y+Rc), s		* 5.2		* 4.9		* 5.2		4.9				
Max Green Setting (Gmax), s		* 41		* 54		* 41		10.1				
Max Q Clear Time (g_c+I1), s		12.1		25.4		14.4		3.6				
Green Ext Time (p_c), s		2.2		1.5		2.2		0.0				
<b>Intersection Summary</b>												
HCM 2010 Ctrl Delay			24.7									
HCM 2010 LOS			C									
<b>Notes</b>												

21: Goldwater Boulevard & Driveway/Scottsdale Road

02/26/2019

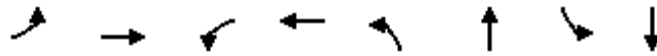

Lane Group	EBL	EBT	WBL	WBT	NBL	NBT	SBL	SBT
Lane Configurations	↶	↷	↶	↷	↶	↷	↶	↷
Traffic Volume (vph)	14	6	633	23	21	369	23	772
Future Volume (vph)	14	6	633	23	21	369	23	772
Turn Type	Split	NA	Split	NA	Perm	NA	Perm	NA
Protected Phases	8	8	4	4		6		2
Permitted Phases					6		2	
Detector Phase	8	8	4	4	6	6	2	2
Switch Phase								
Minimum Initial (s)	7.0	7.0	7.0	7.0	10.0	10.0	10.0	10.0
Minimum Split (s)	13.0	13.0	13.0	13.0	16.0	16.0	16.0	16.0
Total Split (s)	15.0	15.0	59.0	59.0	46.0	46.0	46.0	46.0
Total Split (%)	12.5%	12.5%	49.2%	49.2%	38.3%	38.3%	38.3%	38.3%
Yellow Time (s)	3.3	3.3	3.3	3.3	4.0	4.0	4.0	4.0
All-Red Time (s)	1.6	1.6	1.6	1.6	1.2	1.2	1.2	1.2
Lost Time Adjust (s)	0.0	0.0	0.0	0.0	0.0	0.0	0.0	0.0
Total Lost Time (s)	4.9	4.9	4.9	4.9	5.2	5.2	5.2	5.2
Lead/Lag	Lead	Lead	Lag	Lag				
Lead-Lag Optimize?								
Recall Mode	None	None	Ped	Ped	C-Max	C-Max	C-Max	C-Max
Act Effct Green (s)	7.6	7.6	34.9	34.9	67.2	67.2	67.2	67.2
Actuated g/C Ratio	0.06	0.06	0.29	0.29	0.56	0.56	0.56	0.56
v/c Ratio	0.13	0.19	0.76	0.74	0.08	0.21	0.05	0.30
Control Delay	55.1	57.1	48.1	46.5	27.7	21.2	10.5	10.0
Queue Delay	0.0	0.0	0.0	0.0	0.0	0.0	0.0	0.0
Total Delay	55.1	57.1	48.1	46.5	27.7	21.2	10.5	10.0
LOS	E	E	D	D	C	C	B	B
Approach Delay		56.2		47.3		21.5		10.0
Approach LOS		E		D		C		B

Intersection Summary

Cycle Length: 120  
 Actuated Cycle Length: 120  
 Offset: 40 (33%), Referenced to phase 2:SBTL and 6:NBTL, Start of 1st Green  
 Natural Cycle: 55  
 Control Type: Actuated-Coordinated  
 Maximum v/c Ratio: 0.76  
 Intersection Signal Delay: 26.3  
 Intersection Capacity Utilization 54.2%  
 Analysis Period (min) 15  
 Intersection LOS: C  
 ICU Level of Service A

Splits and Phases: 21: Goldwater Boulevard & Driveway/Scottsdale Road

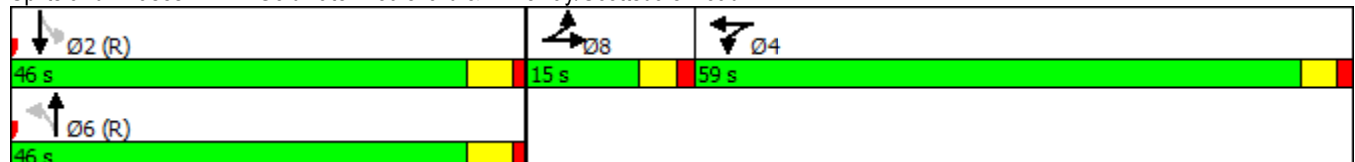

Intersection						
Int Delay, s/veh	0.1					
Movement	EBL	EBT	WBT	WBR	SBL	SBR
Lane Configurations		↑↑↑	↑↑			↑
Traffic Vol, veh/h	0	792	395	42	0	12
Future Vol, veh/h	0	792	395	42	0	12
Conflicting Peds, #/hr	0	0	0	0	0	0
Sign Control	Free	Free	Free	Free	Stop	Stop
RT Channelized	-	None	-	None	-	None
Storage Length	-	-	-	-	-	0
Veh in Median Storage, #	-	0	0	-	0	-
Grade, %	-	0	0	-	0	-
Peak Hour Factor	92	92	92	92	92	92
Heavy Vehicles, %	2	2	2	2	2	2
Mvmt Flow	0	861	429	46	0	13
Major/Minor	Major1	Major2	Minor2			
Conflicting Flow All	-	0	-	0	-	238
Stage 1	-	-	-	-	-	-
Stage 2	-	-	-	-	-	-
Critical Hdwy	-	-	-	-	-	6.94
Critical Hdwy Stg 1	-	-	-	-	-	-
Critical Hdwy Stg 2	-	-	-	-	-	-
Follow-up Hdwy	-	-	-	-	-	3.32
Pot Cap-1 Maneuver	0	-	-	-	0	763
Stage 1	0	-	-	-	0	-
Stage 2	0	-	-	-	0	-
Platoon blocked, %	-	-	-	-	-	-
Mov Cap-1 Maneuver	-	-	-	-	-	763
Mov Cap-2 Maneuver	-	-	-	-	-	-
Stage 1	-	-	-	-	-	-
Stage 2	-	-	-	-	-	-
Approach	EB	WB	SB			
HCM Control Delay, s	0	0	9.8			
HCM LOS				A		
Minor Lane/Major Mvmt	EBT	WBT	WBR	SBLn1		
Capacity (veh/h)	-	-	-	763		
HCM Lane V/C Ratio	-	-	-	0.017		
HCM Control Delay (s)	-	-	-	9.8		
HCM Lane LOS	-	-	-	A		
HCM 95th %tile Q(veh)	-	-	-	0.1		

Intersection						
Int Delay, s/veh	2.1					
Movement	EBT	EBR	WBL	WBT	NBL	NBR
Lane Configurations						
Traffic Vol, veh/h	76	29	25	103	11	32
Future Vol, veh/h	76	29	25	103	11	32
Conflicting Peds, #/hr	0	0	0	0	0	0
Sign Control	Free	Free	Free	Free	Stop	Stop
RT Channelized	-	None	-	None	-	None
Storage Length	-	-	-	-	0	-
Veh in Median Storage, #	0	-	-	0	0	-
Grade, %	0	-	-	0	0	-
Peak Hour Factor	92	92	92	92	92	92
Heavy Vehicles, %	2	2	2	2	2	2
Mvmt Flow	83	32	27	112	12	35
Major/Minor	Major1	Major2	Minor1			
Conflicting Flow All	0	0	114	0	264	98
Stage 1	-	-	-	-	98	-
Stage 2	-	-	-	-	166	-
Critical Hdwy	-	-	4.12	-	6.42	6.22
Critical Hdwy Stg 1	-	-	-	-	5.42	-
Critical Hdwy Stg 2	-	-	-	-	5.42	-
Follow-up Hdwy	-	-	2.218	-	3.518	3.318
Pot Cap-1 Maneuver	-	-	1475	-	725	958
Stage 1	-	-	-	-	926	-
Stage 2	-	-	-	-	863	-
Platoon blocked, %	-	-	-	-	-	-
Mov Cap-1 Maneuver	-	-	1475	-	711	958
Mov Cap-2 Maneuver	-	-	-	-	711	-
Stage 1	-	-	-	-	926	-
Stage 2	-	-	-	-	846	-
Approach	EB	WB	NB			
HCM Control Delay, s	0	1.5	9.3			
HCM LOS			A			
Minor Lane/Major Mvmt	NBLn1	EBT	EBR	WBL	WBT	
Capacity (veh/h)	880	-	-	1475	-	
HCM Lane V/C Ratio	0.053	-	-	0.018	-	
HCM Control Delay (s)	9.3	-	-	7.5	0	
HCM Lane LOS	A	-	-	A	A	
HCM 95th %tile Q(veh)	0.2	-	-	0.1	-	

Intersection						
Int Delay, s/veh	2.3					
Movement	EBL	EBR	NBL	NBT	SBT	SBR
Lane Configurations						
Traffic Vol, veh/h	11	2	14	12	18	38
Future Vol, veh/h	11	2	14	12	18	38
Conflicting Peds, #/hr	0	0	0	0	0	0
Sign Control	Stop	Stop	Free	Free	Free	Free
RT Channelized	-	None	-	None	-	None
Storage Length	0	-	-	-	-	-
Veh in Median Storage, #	0	-	-	0	0	-
Grade, %	0	-	-	0	0	-
Peak Hour Factor	92	92	92	92	92	92
Heavy Vehicles, %	2	2	2	2	2	2
Mvmt Flow	12	2	15	13	20	41
Major/Minor	Minor2	Major1		Major2		
Conflicting Flow All	83	40	61	0	-	0
Stage 1	40	-	-	-	-	-
Stage 2	43	-	-	-	-	-
Critical Hdwy	6.42	6.22	4.12	-	-	-
Critical Hdwy Stg 1	5.42	-	-	-	-	-
Critical Hdwy Stg 2	5.42	-	-	-	-	-
Follow-up Hdwy	3.518	3.318	2.218	-	-	-
Pot Cap-1 Maneuver	919	1031	1542	-	-	-
Stage 1	982	-	-	-	-	-
Stage 2	979	-	-	-	-	-
Platoon blocked, %				-	-	-
Mov Cap-1 Maneuver	910	1031	1542	-	-	-
Mov Cap-2 Maneuver	910	-	-	-	-	-
Stage 1	982	-	-	-	-	-
Stage 2	969	-	-	-	-	-
Approach	EB	NB		SB		
HCM Control Delay, s	8.9	4		0		
HCM LOS	A					
Minor Lane/Major Mvmt	NBL	NBT	EBLn1	SBT	SBR	
Capacity (veh/h)	1542	-	927	-	-	
HCM Lane V/C Ratio	0.01	-	0.015	-	-	
HCM Control Delay (s)	7.4	0	8.9	-	-	
HCM Lane LOS	A	A	A	-	-	
HCM 95th %tile Q(veh)	0	-	0	-	-	

Intersection						
Int Delay, s/veh	0.9					
Movement	EBT	EBR	WBL	WBT	NBL	NBR
Lane Configurations						
Traffic Vol, veh/h	91	0	0	103	10	11
Future Vol, veh/h	91	0	0	103	10	11
Conflicting Peds, #/hr	0	0	0	0	0	0
Sign Control	Free	Free	Free	Free	Stop	Stop
RT Channelized	-	None	-	None	-	None
Storage Length	-	-	-	-	0	-
Veh in Median Storage, #	0	-	-	0	0	-
Grade, %	0	-	-	0	0	-
Peak Hour Factor	92	92	92	92	92	92
Heavy Vehicles, %	2	2	2	2	2	2
Mvmt Flow	99	0	0	112	11	12
Major/Minor	Major1	Major2	Minor1			
Conflicting Flow All	0	0	99	0	211	99
Stage 1	-	-	-	-	99	-
Stage 2	-	-	-	-	112	-
Critical Hdwy	-	-	4.12	-	6.42	6.22
Critical Hdwy Stg 1	-	-	-	-	5.42	-
Critical Hdwy Stg 2	-	-	-	-	5.42	-
Follow-up Hdwy	-	-	2.218	-	3.518	3.318
Pot Cap-1 Maneuver	-	-	1494	-	777	957
Stage 1	-	-	-	-	925	-
Stage 2	-	-	-	-	913	-
Platoon blocked, %	-	-	-	-	-	-
Mov Cap-1 Maneuver	-	-	1494	-	777	957
Mov Cap-2 Maneuver	-	-	-	-	777	-
Stage 1	-	-	-	-	925	-
Stage 2	-	-	-	-	913	-
Approach	EB	WB	NB			
HCM Control Delay, s	0	0	9.3			
HCM LOS					A	
Minor Lane/Major Mvmt	NBLn1	EBT	EBR	WBL	WBT	
Capacity (veh/h)	862	-	-	1494	-	
HCM Lane V/C Ratio	0.026	-	-	-	-	
HCM Control Delay (s)	9.3	-	-	0	-	
HCM Lane LOS	A	-	-	A	-	
HCM 95th %tile Q(veh)	0.1	-	-	0	-	