

NOTE:
 1. MAXIMUM SPACING OF CONTRACTION JOINTS IS 10'-0".
 2. TOP OF CURB SHALL SLOPE WITH CONTOURS AND REMAIN 4" ABOVE ADJACENT GRADE. SEE CIVIL DRAWINGS FOR GRADES.

5 LANDSCAPING CURB
 SCALE: 3/4"=1'-0"

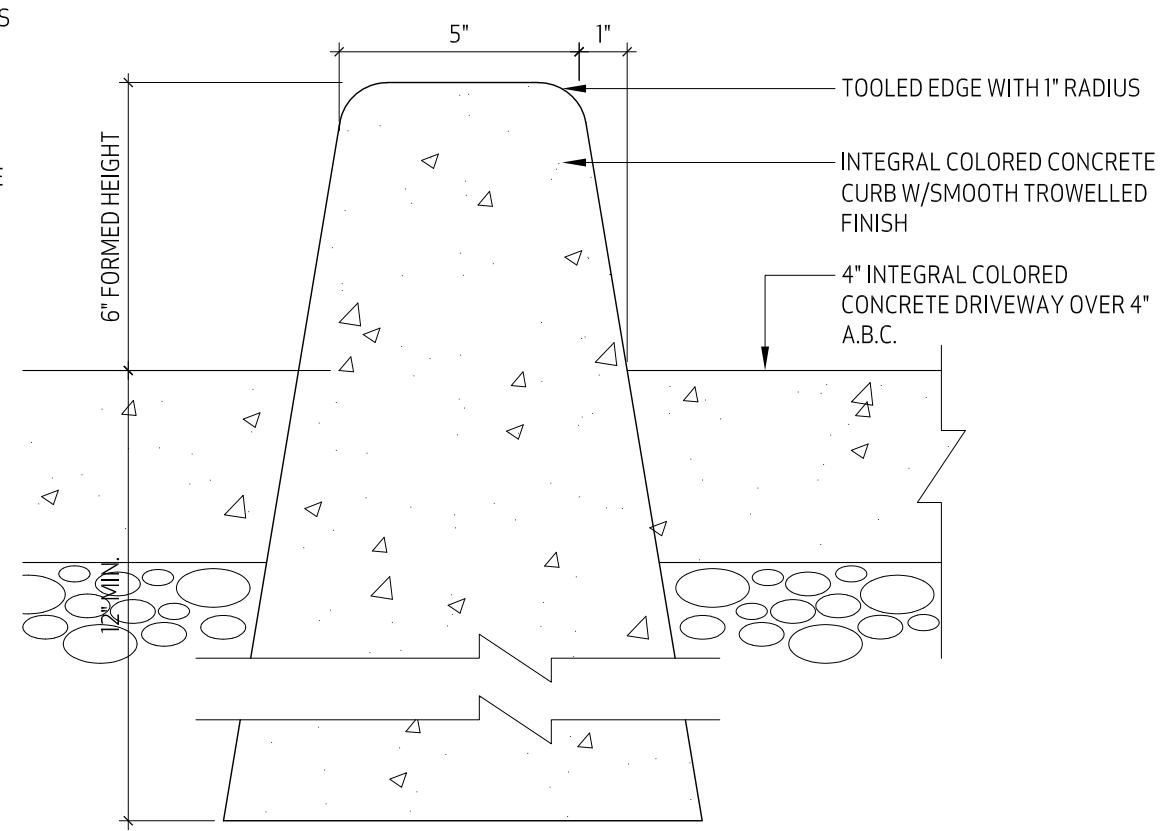

4 PARKING CURB
 SCALE: 3/4"=1'-0"

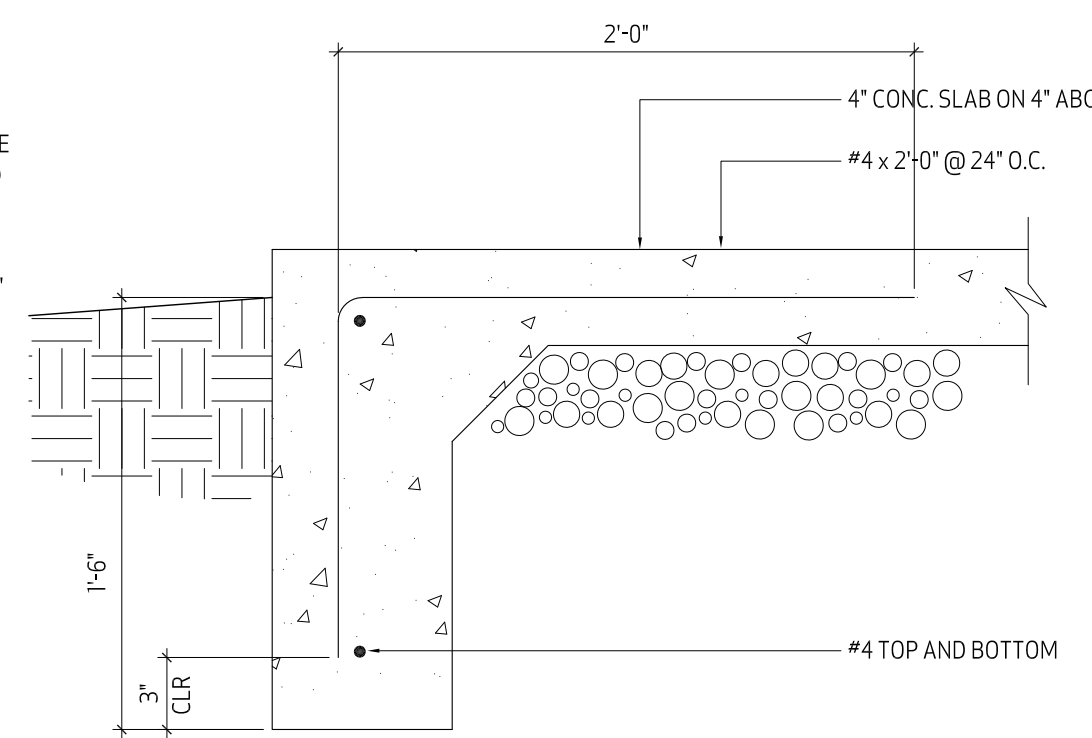

3 TURNDOWN AT SLAB EDGE

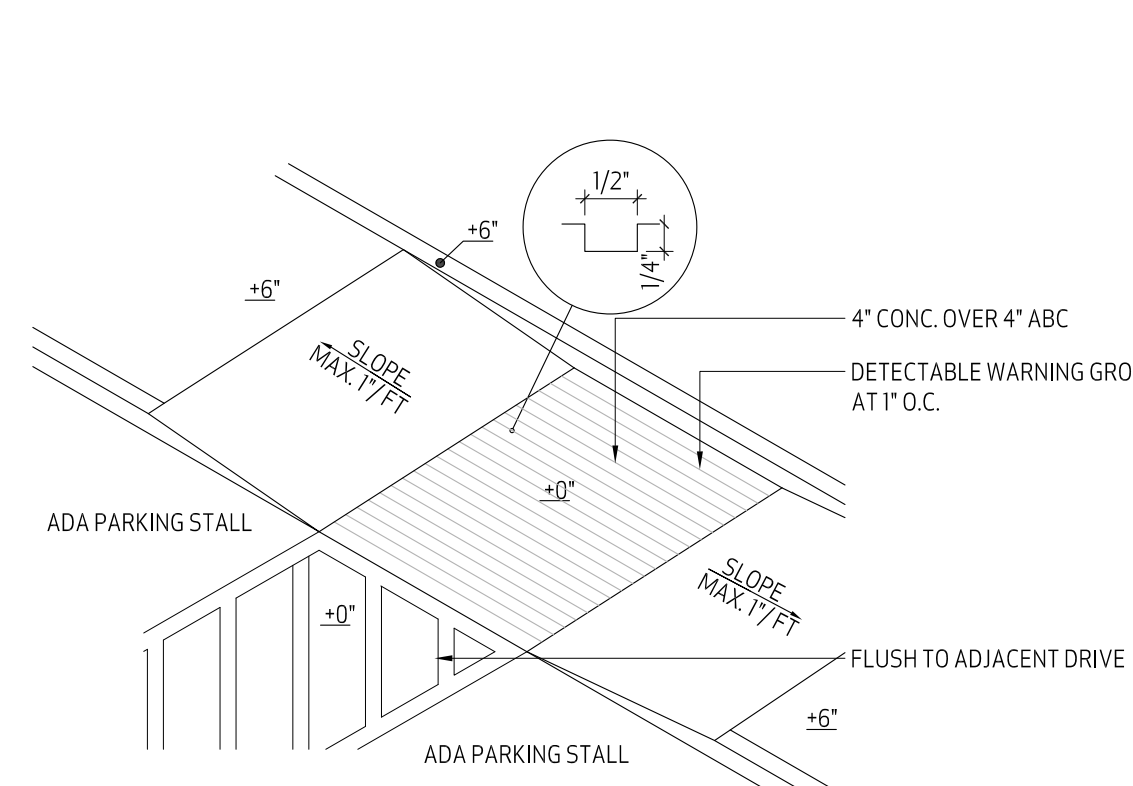

2 ACCESSIBLE PATH
 SCALE: 1/4"=1'-0"

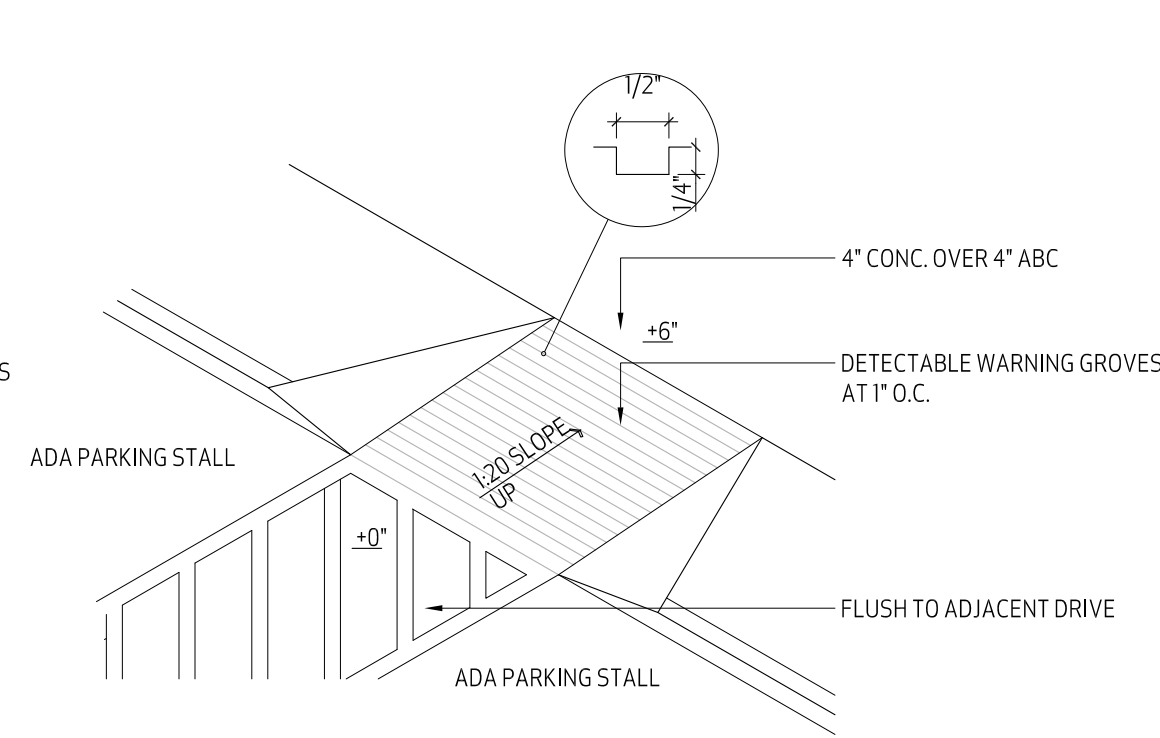

1 ACCESSIBLE PATH
 SCALE: 1/4"=1'-0"

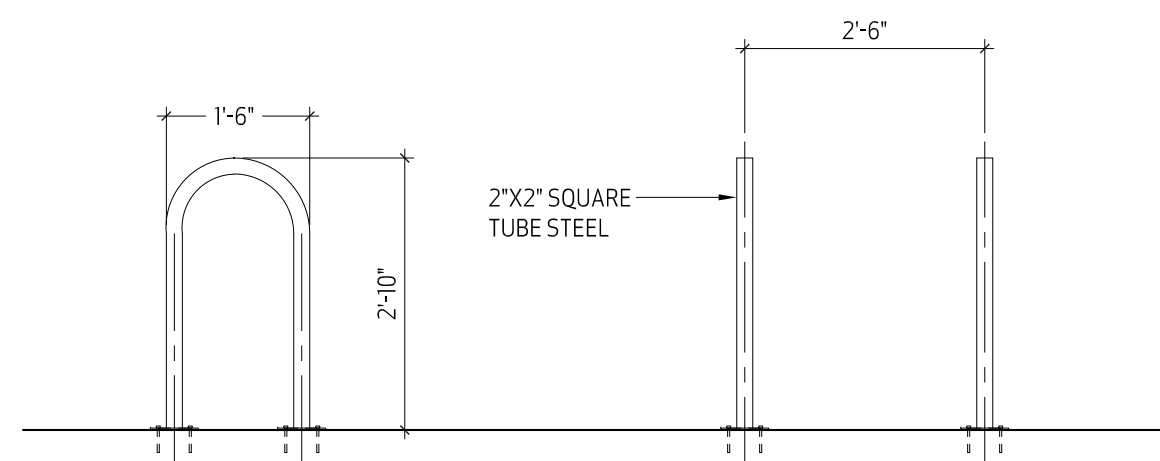

ALL CONNECTIONS ARE WELDED EXCEPT BASE ATTACHMENT. ALL WELDS TO BE CONTINUOUS AND GROUND SMOOTH. ANY GAPS TO BE FILLED.

9 BICYCLE RACK
 SCALE: 1/2"=1'-0"

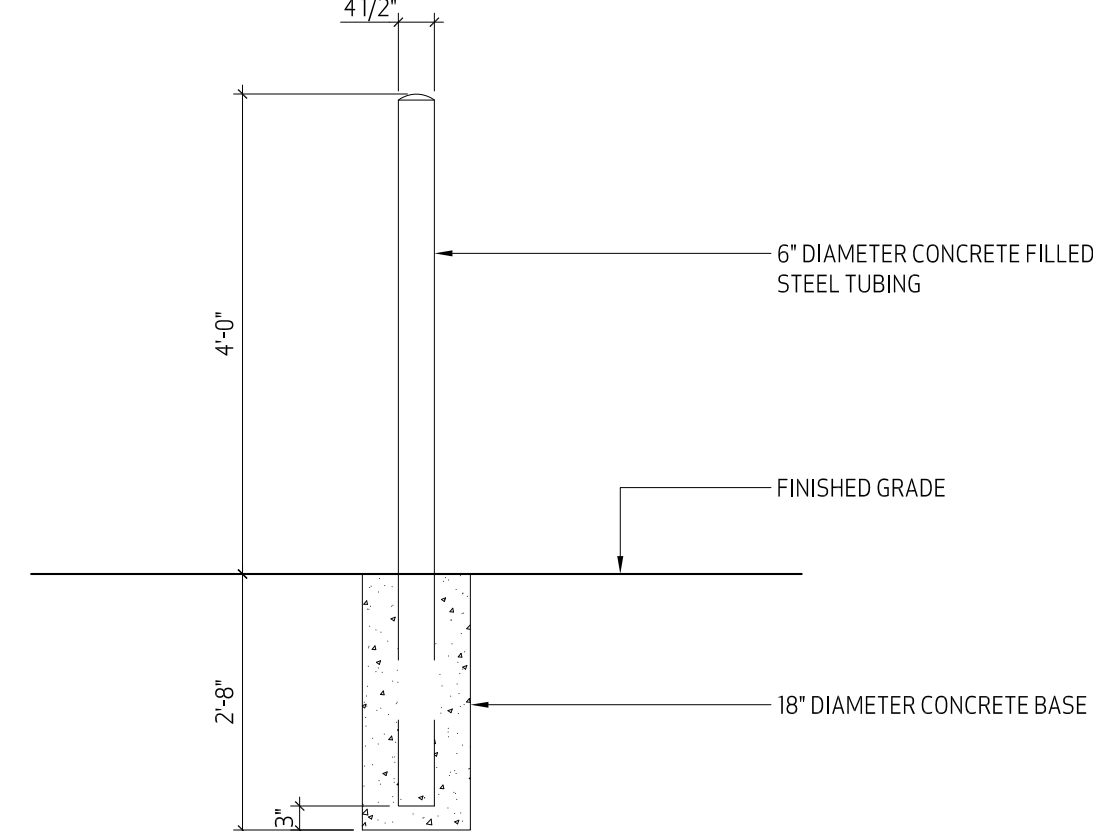

8 BOLLARD DETAIL
 SCALE: 1/2"=1'-0"

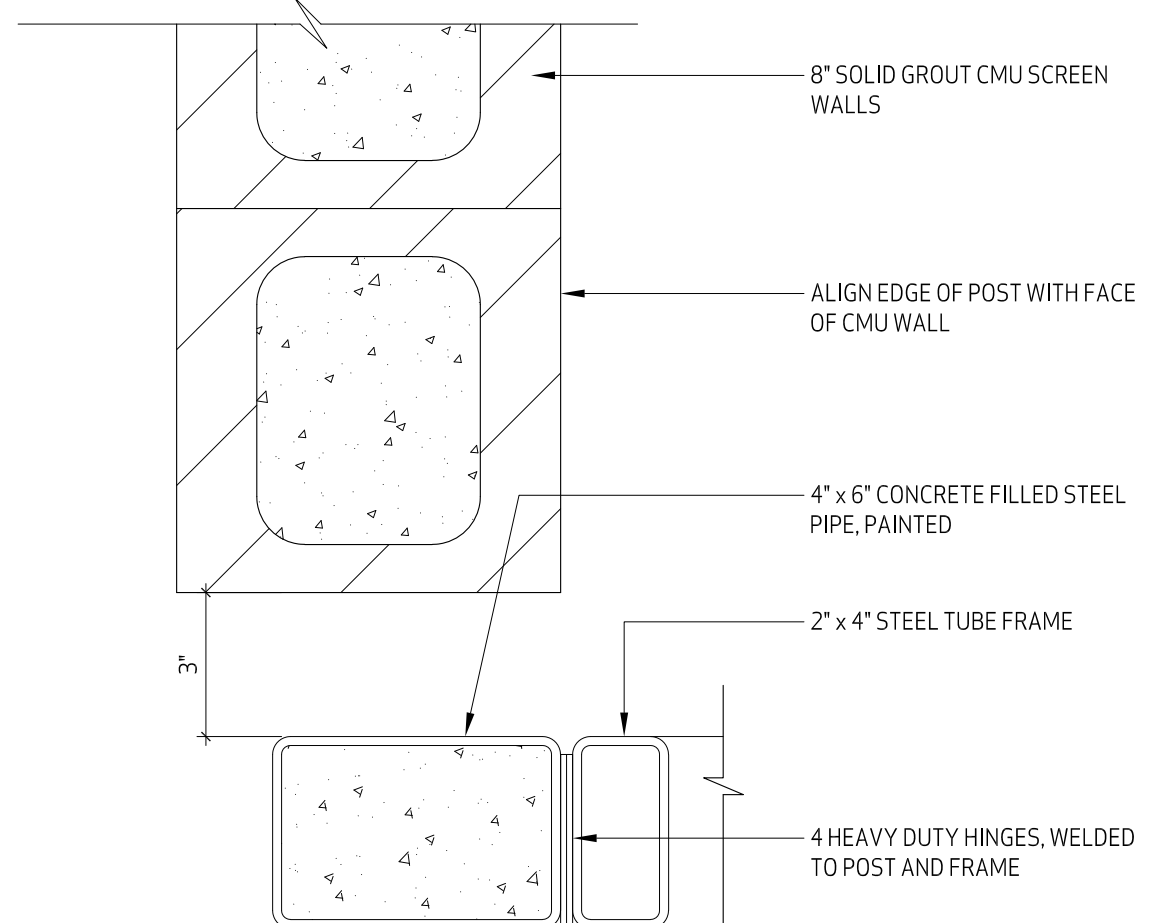

7 GATE POST
 SCALE: 3/4"=1'-0"

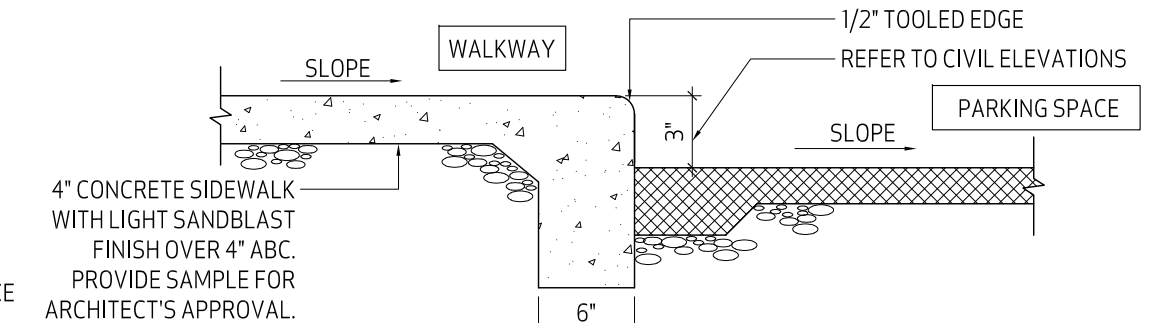

6B WALKWAY AT PARKING
 SCALE: 1/2"=1'-0"

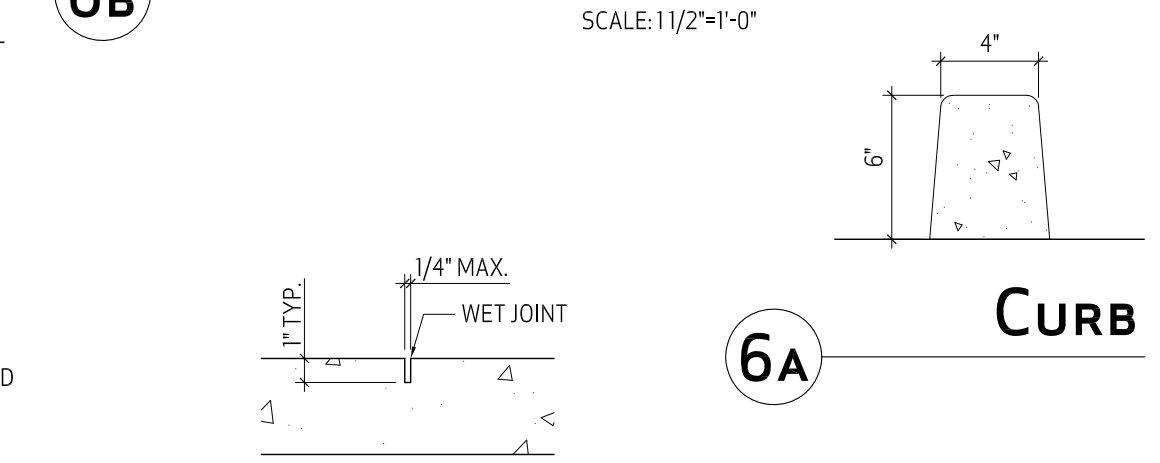

6A CURB
 SCALE: 1/2"=1'-0"

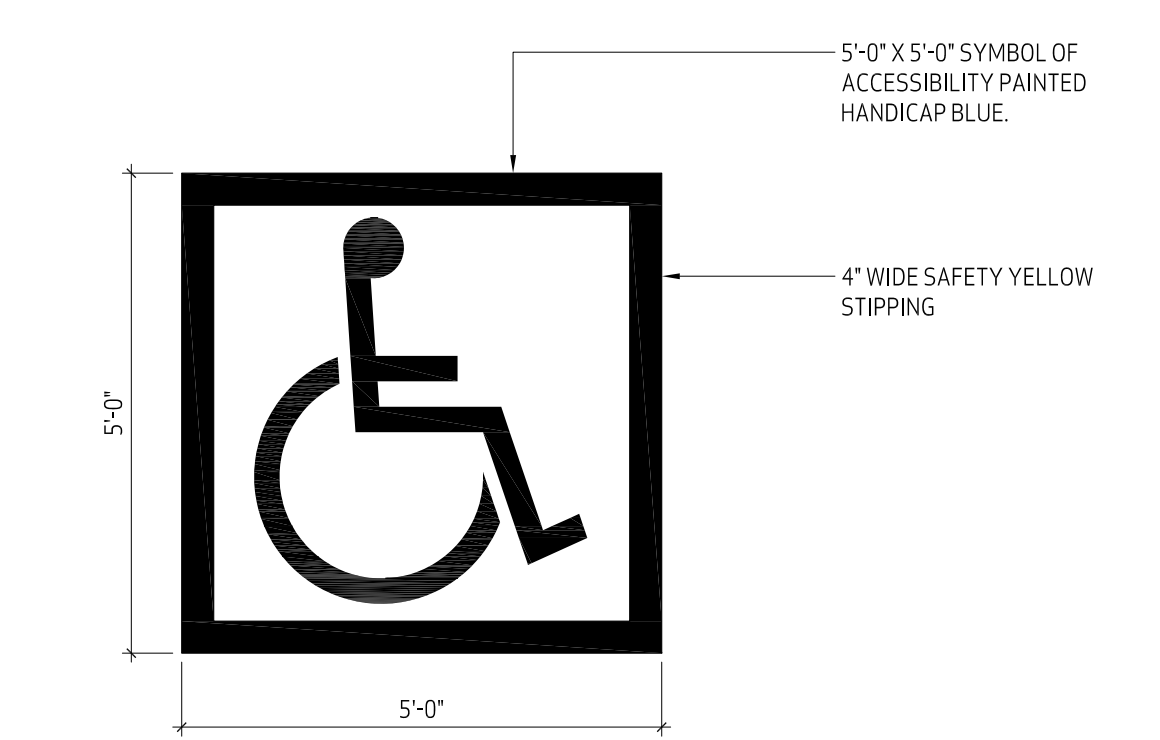

13 ACCESSIBLE PARKING SIGN
 SCALE: 1/2"=1'-0"

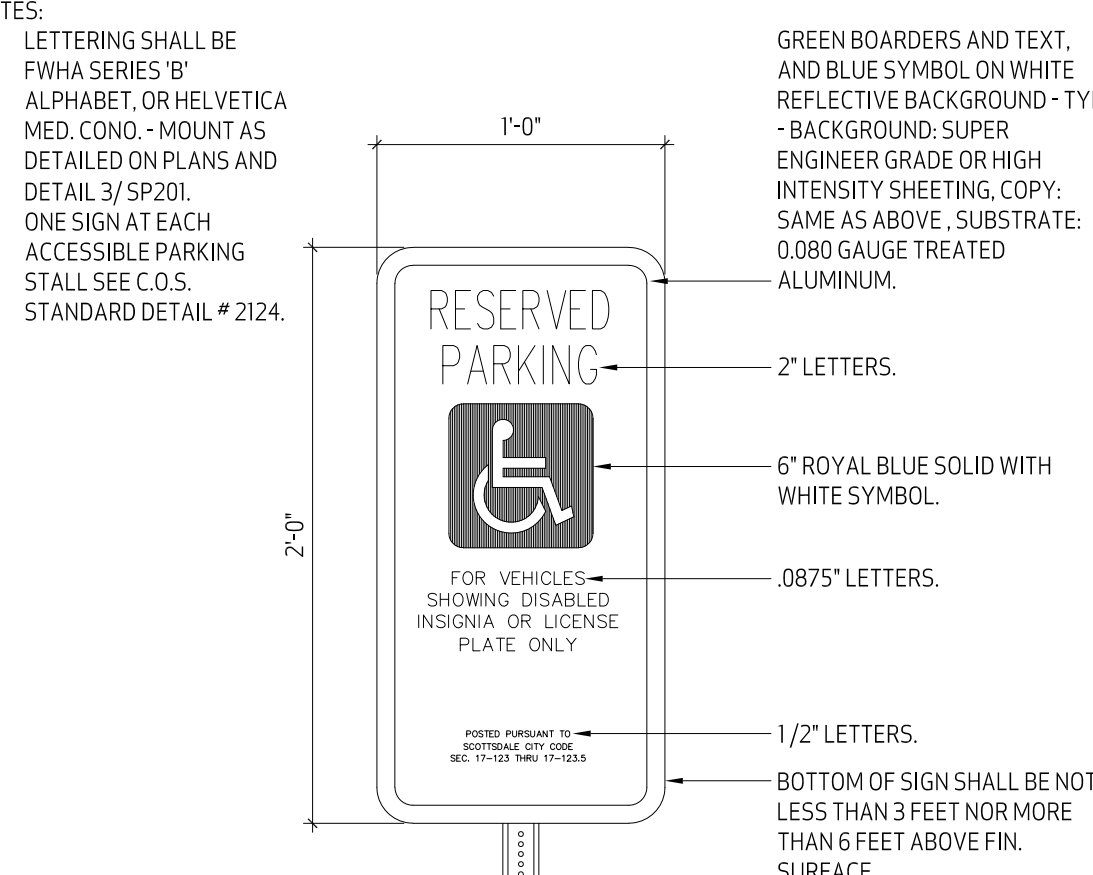

12 ACCESSIBLE SIGNAGE (SCOTTSDALE)
 SCALE: 1/2"=1'-0"

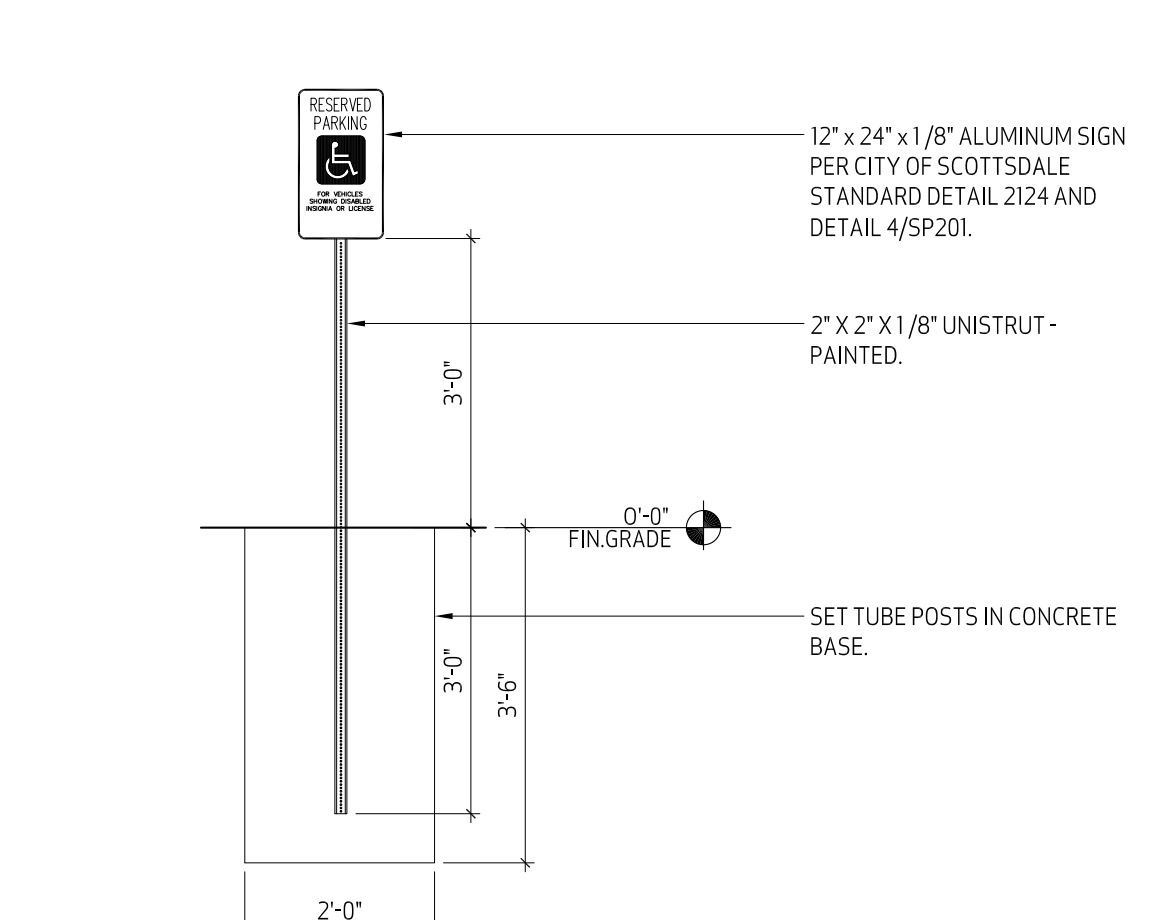

11 ACCESSIBLE SIGN (SCOTTSDALE)
 SCALE: 1/2"=1'-0"

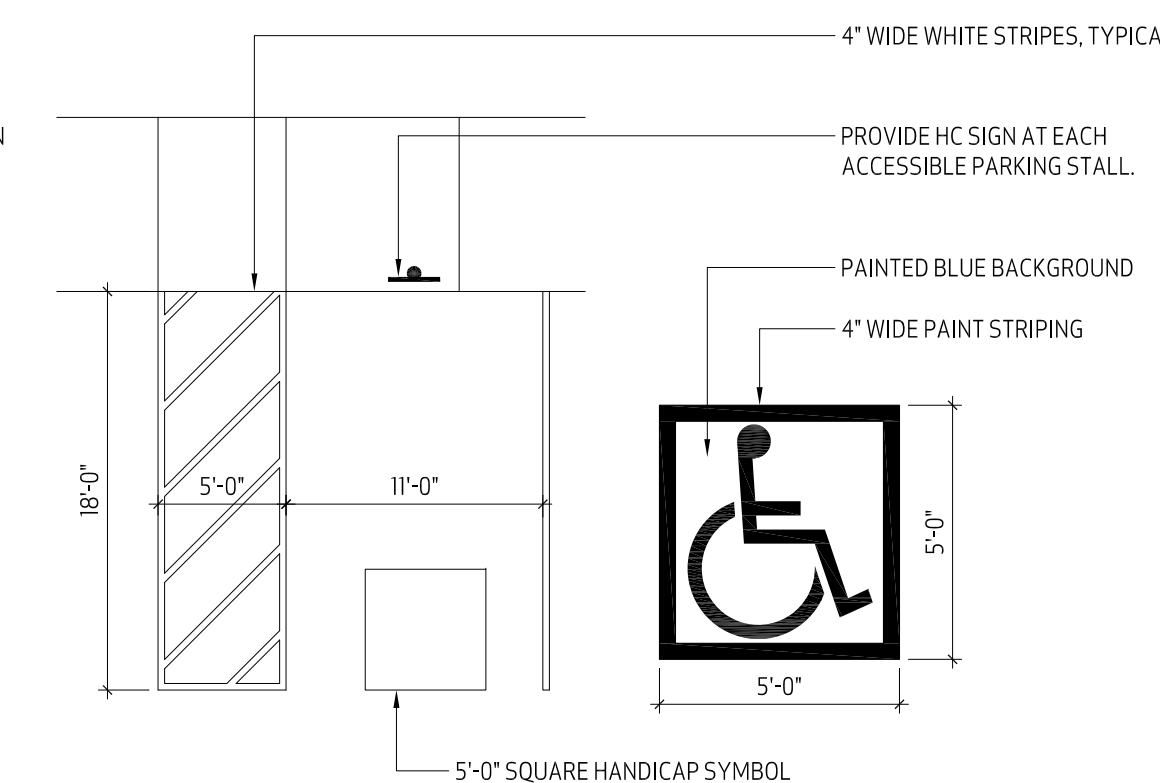

10 ACCESSIBLE PARKING
 SCALE: NTS

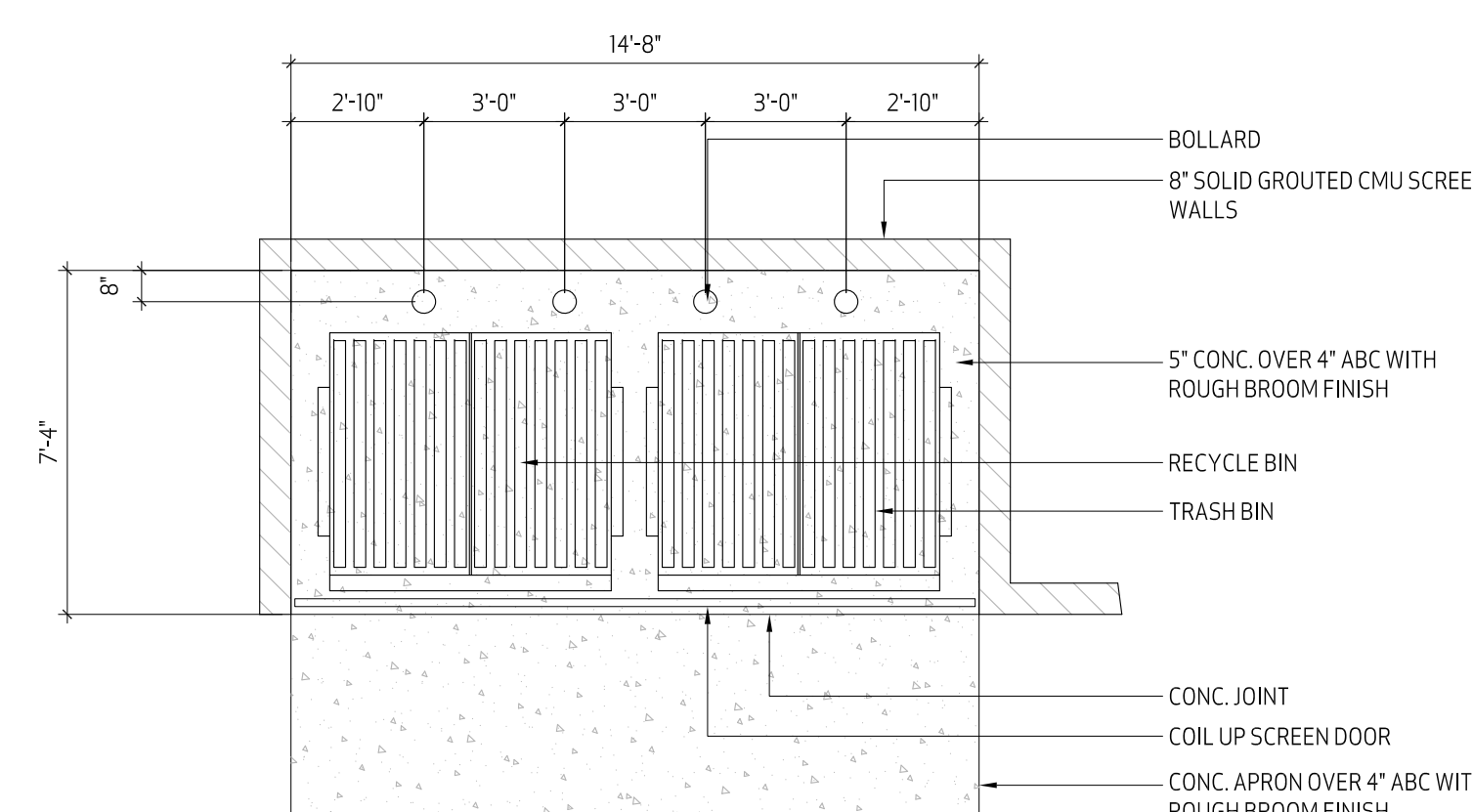

14 ENLARGED PLAN OF TRASH ENCLOSURE
 SCALE: 1/4"=1'-0"

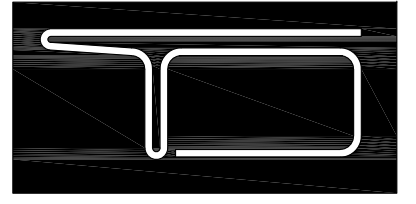

TOMECAK DESIGN
 4368 NORTH CIVIC CENTER PLAZA
 SUITE 201
 SCOTTSDALE, ARIZONA 85251
 T 602.619.7751
 F 480.718.8387
 E INFO@TOMECAKDESIGN.COM

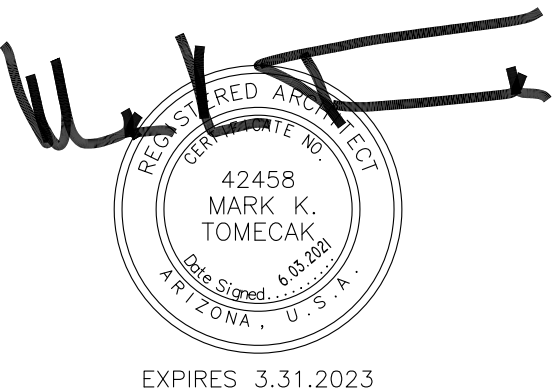

PROJECT:
PALO ON 75TH
 3961 N. 75TH STREET
 SCOTTSDALE, ARIZONA 85251

REVISED:
 JOB #.: 2105
 DATE: 06.03.2021
 CONTENTS: SITE DETAILS
 SHEET NO: CS0.2

THIS DRAWING IS AN INSTRUMENT OF SERVICE AND THE PROPERTY OF TOMECAK DESIGN, P.C. AND SHALL REMAIN THEIR PROPERTY. THE USE OF THIS DRAWING SHALL BE RESTRICTED TO THE ORIGINAL SITE FOR WHICH IT WAS PREPARED AND PUBLICATION THEREOF IS EXPRESSLY LIMITED TO SUCH USE. REUSE, REPRODUCTION OR PUBLICATION OF ANY PART IS PROHIBITED WITHOUT THEIR WRITTEN CONSENT.