

NOTE: PLAN ORIENTATION MODIFIED TO BEST SHOW TRASH COMPACTOR ON SHEET

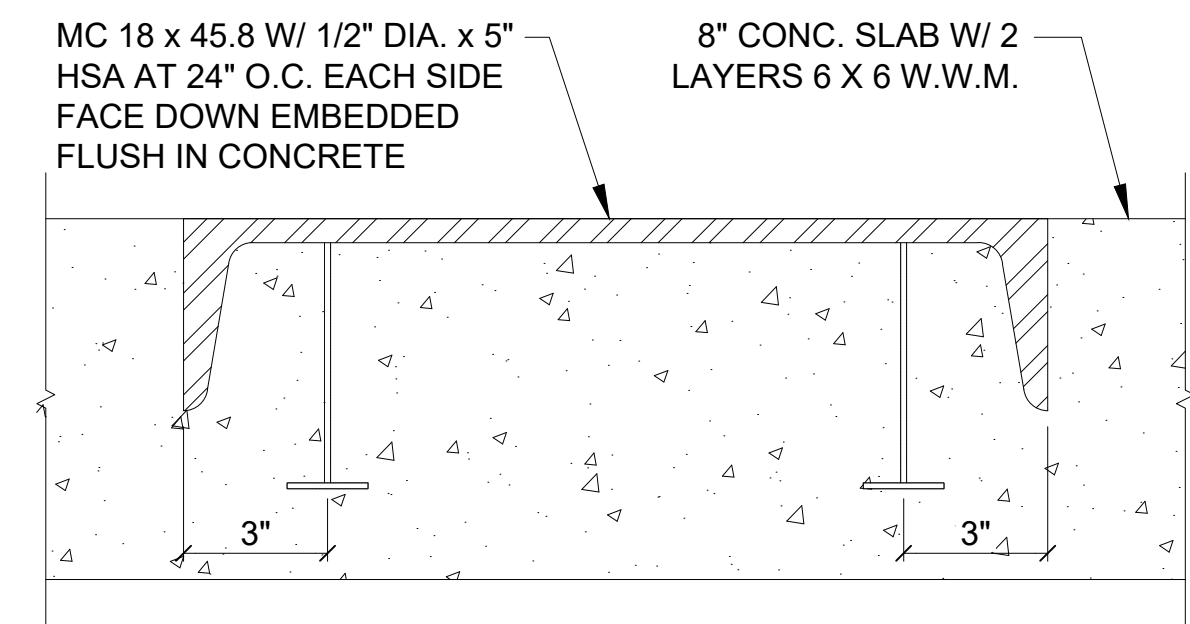
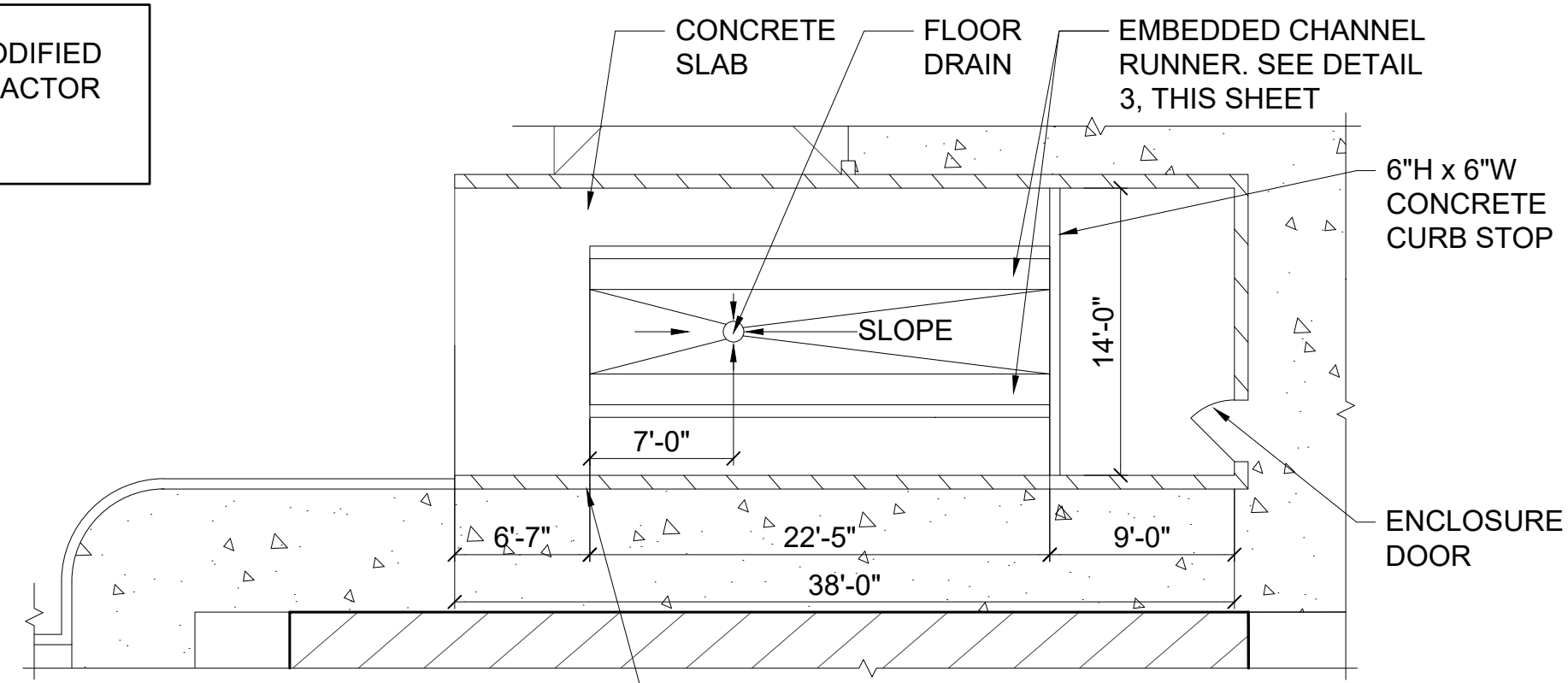

2 TRASH COMPACTOR PLAN
scale: 1"= 40'

3 CHANNEL RUNNER INSERT
scale: 3"= 1'-0"

	UNITS (SPECIALIZED & MINIMAL CARE)	NON-RESIDENTIAL AREAS
BUILDING 1	78	30,105
BUILDING 2	10	2,017
TOTAL	88	32,122

	UNITS (SPECIALIZED & MINIMAL CARE)	NON-RESIDENTIAL AREAS	REQUIRED NUMBER OF REFUSE ENCLOSURES*
1 ENCLOSURE FOR FIRST 10,000 S.F. OF NON-RESIDENTIAL AREA AND FIRST 10 UNITS*	10	10,000	1
1 ENCLOSURE FOR EACH ADDITIONAL 20 UNITS*	78		4 (78 / 20 = 3.9)
1 ENCLOSURE FOR EACH 20,000 S.F. OF NON-RESIDENTIAL AREA*		22,122	2 (22,122 / 20,000 = 1.1)
TOTAL	88	32,122	7

* PER TABLE 2-1.311.B.

REQUIRED	7 ENCLOSURES	4 CU YDS PER ENCLOSURE	28 CU YDS OVERALL CAPACITY REQUIRED
----------	--------------	------------------------	-------------------------------------

PROPOSED	COMPACTOR: ONE (1) TOTAL CAPACITY: 34 CU YDS MODEL: RJ-250SC BY RAMJET OR APPROVED EQUIVALENT
----------	---

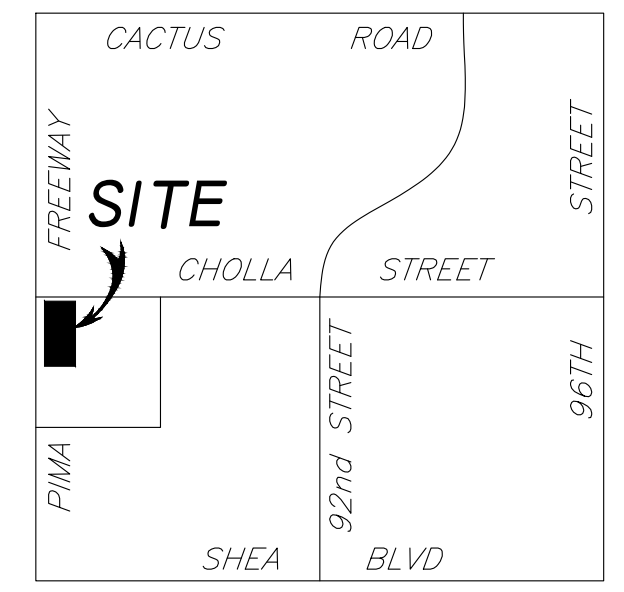

VICINITY MAP
N.T.S.

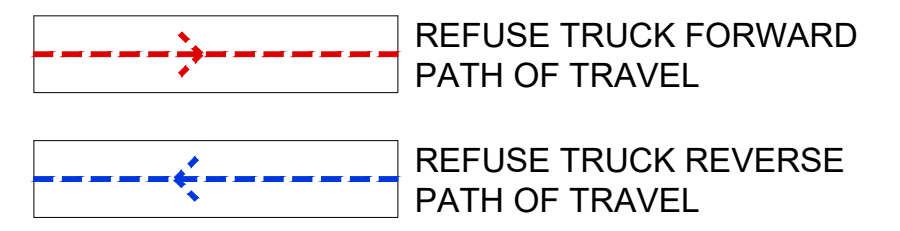
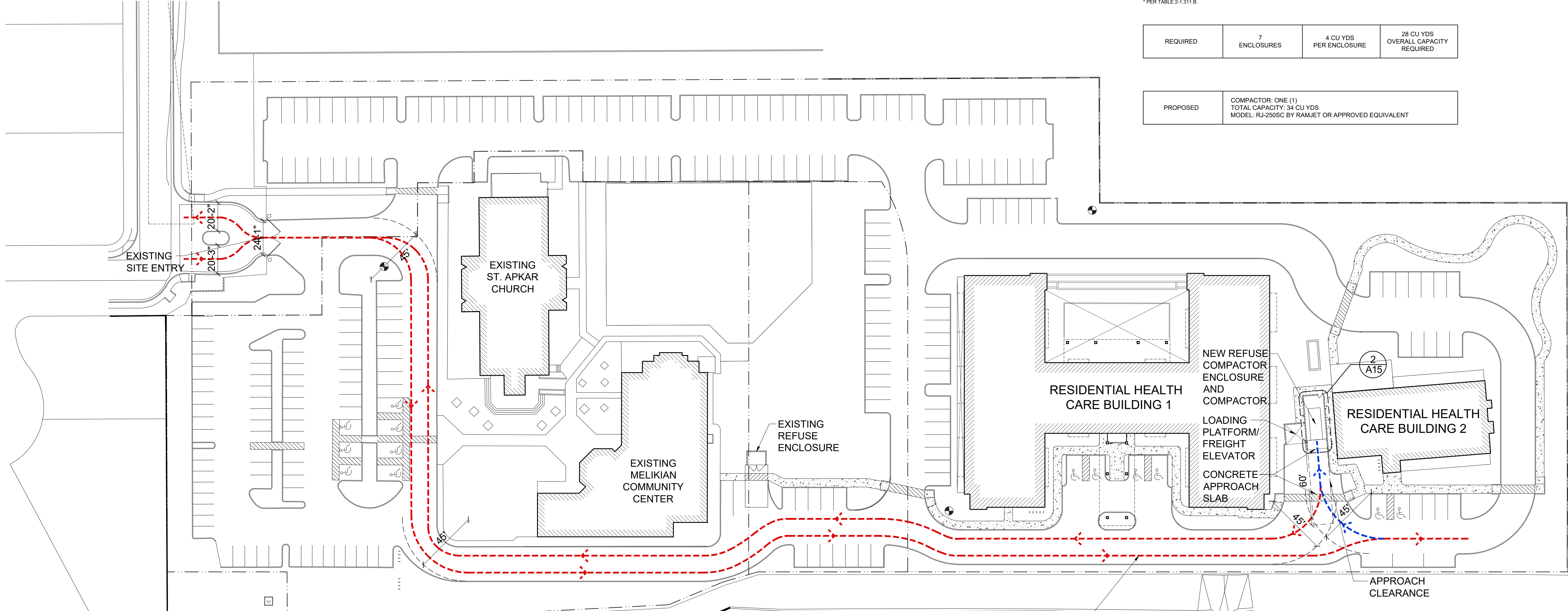
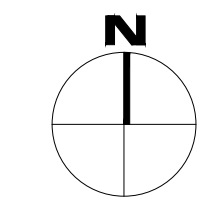

1 REFUSE PLAN
scale: 1"= 40'



**MEGERDICHIAN
SENIOR CENTER**
8849 E. CHOLLA ST.
SCOTTSDALE, AZ 85260

PRE-CONSTRUCTION PHASE		
NO.	ISSUED FOR:	DATE
	REZONING & C.U.P.	12-13-2018
	REZONING & C.U.P. 2nd Review	10-06-2020
	REZONING & C.U.P. 3rd Review	12-09-2020

CONSTRUCTION PHASE		
REV.	BULLETIN #	DATE

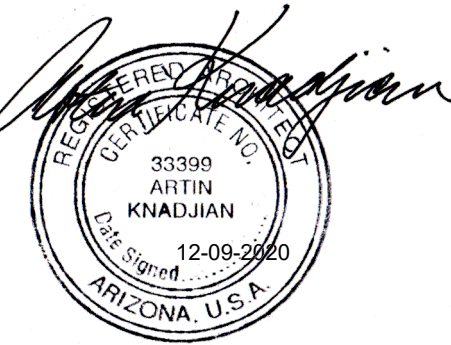

SHEET TITLE
REFUSE PLAN

SCALE: 1"= 40'
DATE: 12/09/2020
JOB NUMBER: 1727-00

A15