



**KLAND CIVIL ENGINEERS**

# Preliminary Drainage Report

## Megerdichian Assisted Seniors Center (MASC)

8849 E CHOLLA ST, SCOTTSDALE, AZ 85260

**25-ZN-2018**

Kland# K15153

### Prepared for:

AAk Architecture & Interiors, Inc.  
7585 E. Redfield Rd., Suite 106  
Scottsdale, AZ 85260-6937  
Contact: Artin Knadjian

### Prepared by:

Kland Civil Engineers, L.L.C.  
7227 North 16th Street, Suite 217  
Phoenix, Arizona 85020  
Contact: Leslie Kland, P.E.

### Submitted to:

City of Scottsdale  
200 W. Washington, 2nd Floor  
Phoenix, AZ, 85003



Revised September 11, 2020  
August 24, 2018

Plan # _____
Case # <u>25-ZN-2018, Cycle V2</u>
Q-S # _____
<input type="checkbox"/> Accepted
<input checked="" type="checkbox"/> Correction
Reviewed By <u>GA</u> Date <u>10/26/20</u>

Please also see drainage comments on the grading and drainage plans and update the report accordingly.

**Table of Contents**

	<u>Page</u>
1. Introduction .....	3
2. Site Description .....	4
3. Existing Drainage .....	5
4. Proposed Drainage .....	6
5. Methodogy .....	7
6. Summary .....	8
7. Reference .....	9

**Appendix**

Appendix A - FEMA Exhibit

Appendix B -Drainage Calculations

Appendix C -Drainage Channel Report and ADOT Plans

Appendix D - Weighted 'C' EXHIBIT

Appendix E - Existing Drainage Map

Appendix F - Proposed Drainage Map

Appendix G - Master Plan



**Revised September 11, 2020  
August 24, 2018**

## 1. Introduction

The purpose of this report is to compare the existing and proposed drainage for the Megerdichian Assisted Seniors Center (MASC) project. The proposed site is located at 8849 E Cholla Street in Scottsdale, AZ 85260.

This report consists of description of existing condition, proposed condition, methods of analysis and conclusion. The drainage report serves to confirm that the proposed project does not affect the existing drainage pattern in a significant way, and has been designed in accordance with our understanding of known applicable City of Scottsdale criteria, requirements and design standards for storm water management.

## 2. Site Description

The Megerdichian Assisted Seniors Center (MASC) is located within a portion of Lot 3 in the Southwest Quarter of Section 19, Township 3 North, Range 5 East of Gila and Salt River base and Meridian, Maricopa County, Arizona. The site is bordered on the west by Pima Freeway, on north by Cholla Street, and on the east and south by previously developed properties. The current zoning of the site is R1-35 according to Maricopa County Assessor's Office.

Please see Vicinity Map below.

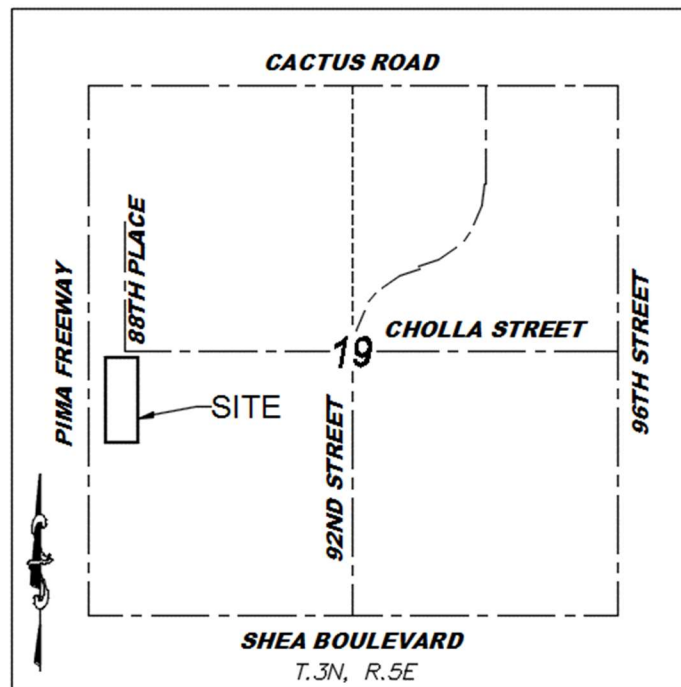

### **VICINITY MAP**

N.T.S.

Currently, the site includes several parking lots and paved driveways, three single story buildings which are connected by a dirt road, and a retention area. The remaining portion on the south of the site is open space area which the proposed development will occur on. The proposed development includes a senior center building (21,800 sf), and the required parking spaces.

Please see Appendix G for Master Plan.

### **Federal Emergency Management Agency (FEMA) Designation**

The subject site lies within Zone X according to on the Federal Emergency Management Agency (FEMA) Flood Insurance Rate Map (FIRM) Map Number 04013C1760L, dated 10/16/2013.

The FIRM Panel defines a Zone X designation as follows:

*Areas of 0.2% annual chance flood; areas of 1% annual chance flood with average depths of less than 1-foot or with drainage areas less than 1 square mile; and areas protected by levees from 1% annual chance flood.*

See Appendix A for FEMA Exhibit.

This referenced study is old. Update channel design flow, or justify it is still valid, or add a statement to indicate that the proposed improvement will not alter the corresponding channel and that the finished floor of proposed structures will be set to adequately protect the structures from any uncertainties of original channel design flow variation

### **3. Existing Drainage**

#### **Offsite Drainage**

There is an existing drainage channel along the north site of the site in the developed portion of the site. This drainage channel collects storm water from the existing residential neighborhood and discharges to the existing ADOT channel along the west side of the site. The north channel was designed and sized per the Armenian Apostolic Church Drainage Report prepared by Speedie and Associates, Dated 10/27/1989. According to the Drainage report the 100-year peak flow was calculated to be 74 cfs and the 10-year peak flow to be 39 cfs. The drainage channel was designed to have a capacity over 80 cfs. The ADOT channel plans show that the channel was sized for the 100-year peak flow. The profiles show that the channel generally provides 1-foot of freeboard to the 100-yr hydraulic grade line. There is a hydraulic jump at the far south end of the site that appears to be due to a maintenance access ramp into the bottom of the drainage channel. At this point the freeboard is reduced approximately 0.25-feet which provided approximately 1.7-feet of free board to the existing building.

#### **Onsite Drainage**

The grading and drainage plans show this pipe as continuous across the ADOT channel. Please check !

Clarify calculations provided in the appendix and why some basins have no drywells. If surface percolation is considered, indicate so and either provide supporting calculation based on a tested rate or indicate that it will be provided in the final drainage report. A note can be added to indicate that the number of drywells can be adjusted at the time of construction based on actual tested rates. Calculations for the three basins in sub-area C should be done separately

The site slopes from the north to the east with an approximately 5 feet of fall. For the portion of the site that is developed there is an existing retention basin that accept most the storm water runoff.

Per the engineering documents for the developed part, the retention volume required for the 100-year-2-hour storm event is 28,770 cft and the volume provided in the retention basin is 30,400 cft. Per our modeling with Civil 3d using survey data, we calculated the retention volume provided in this basin about 17,602 cft. We are proposing expansion of this basin to provide about 37,000 cft and three drywells for water dissipation in less than 36 hours per 0.1 cfs dissipation rate. The volume provided will be adequate for this phase of development and any potential future ones.

The historic outfall for this basin is via a catch basin provided at the proposed highwater elevation, which connects to an existing 12" storm drain pipe that continues to the west. This pipe will be removed in our proposed plans, and the outfall will be from the parking lot to the east of the basin to the next tributary area and eventually to the ultimate outfall of the site.

Is this the same 12" already discussed above?

There is a small portion of access drive and the trash enclosure that drains directly to the ADOT drainage channel on the west side of the site. In addition, the retention basin has a pipe connection to the ADOT channel that allows excess storm water to overflow to the channel. The south portion of the site that is undeveloped discharges directly to the ADOT channel through a spillway located approximately 250-feet north of the south property line.

Please see Appendix C for Drainage Channel Report and ADOT plans and Appendix E for Existing Drainage Map.

#### 4. Proposed Drainage

Need to discuss the first flush requirements. Since the retention basins are designed for the 100y-2h volume, they can accommodate the first flush, but the subject needs to be discussed

##### Offsite Drainage

No offsite drainage changes are planned with this development. The new development will provide 100-year 2-hour retention which will reduce the current storm water discharge to the ADOT channel. In addition, the overflow pipe from the existing retention basin will be removed. For storm events great than the 100-year storm the site outfall will remain to the ADOT drainage channel as it has historically.

##### Onsite Drainage

Drainage easements will be required around all retention basins and any required special access way. Please discuss in the report and show on the grading and drainage plans. These easement will need to be dedicated.

For the purpose of the stormwater management the required retention will be provided in surface basins and underground retention tanks. The existing retention basin will be enlarged with this development as narrated above in the Existing Drainage/Onsite. In addition there are 4 proposed surface basins along the east and south side of the new development The 10' diameter underground retention tanks are located in the southeast corner of the site.

All existing and new finished floors are set to be at least 1' above the original high

Drainage Report  
Megerdichian Assisted Seniors Center (MASC)

Kland Civil Engineers  
#K15153

See the grading and drainage plans for additional requirements for underground systems.

The 1 ft above the WSEL is typically for flowing water. When it comes to basins, the FF needs to be also safely above the basin outfall in case the storm exceeds capacity. The statement may need to be edited.

water elevations of the retention basins. In order to maintain the existing drainage pattern, we are providing catch basins to catch the storm water flow through the drives. The catch basins are connected to the underground storage tanks via storm drain pipes. The underground retention tanks are in the parking area on the east side of the southern portion of the property to not impact the ability to plant trees or water easement. Storm water in excess of the retention tank volume will back up the storm pipe and overflow at the ultimate outfall/ historic out fall for the site.

?

The Ultimate out fall for the site is located on the west site and drains into an existing drainage channel.

See Appendix F for Proposed Drainage Map and Appendix G for Master Plan.

## 5. Methodology

Calculations are not provided. Either provide or indicate that calculations will be provided in the final drainage report.

The onsite storm drain system was modeled using Haestad Methods, StormCAD v5.5. The anticipated 100-year peak flows contributing to the storm drain inlets and building roof drains were calculated using the Rational Method. To study the effect of this development on the natural drainage characteristics, the weighted runoff coefficient was calculated to be 0.81. The 100-year intensity was also determined using NOAA Atlas 14, Volume 1, Version 5 for a 5-minute time-of-concentration.

$$Q_{100} = CIA$$

$Q_{100}$  = Peak Flow in cubic feet for the selected storm reoccurrence interval

$C$  = Runoff Coefficient

$I$  = Rainfall Intensity (7.55 in/hr per NOAA Atlas 14, Volume 1, Version 5)

$A$  = Drainage Area in Acres

Number below indicates 0.79 ?  
Additionally, a weighted average for the entire site is not useful when multiple basins are proposed. The weighted value should be evaluated separately for the area that contribute to each basin. Update all calculations accordingly. Furthermore, describe how the three retention basins for sub-area C function collectively. Summing individual volumes to meet the total requirements may not be appropriate unless clearly described

The weighted runoff coefficient for the site is calculated based on the runoff coefficients used by the City of Scottsdale which are 0.5 for Landscape and permeable surfaces and 0.95 for Impermeable surfaces:

$$C = (C_p \times A_p + C_i \times A_i) \div (A_p + A_i)$$

$A_p$  = 112,810 sft (Landscape and permeable surfaces)

$A_i$  = 209,680 sft (Impermeable surfaces)

$C_p$  = 0.5

$C_i$  = 0.95

$C = 0.79$

The required retention volume for precipitation depth for 100-year-2-hour storm event was determined by using the following equation:

$$V_r = (P/12) \times (C \times A)$$

$V_r$  = Volume of storm water retention in cubic feet for the selected storm reoccurrence interval

$C$  = 0.81 Runoff Coefficient

$P$  = Rainfall Depth, in inches (2.22" per NOAA Atlas 14, Volume 1, Version 5)

$A$  = Drainage Area in square feet

The required retention for this site will be provided in 282 linear feet of 10' diameter underground retention tanks (retention volume = 22,148 cf) and four retention basins (retention volume = 40,452 cf) providing a total volume equal to 62,425 cf.

See Appendix B for Drainage Calculations and Appendix for Weighted 'C' Exhibit.

Clarify and discuss the role of the enlarged existing basin

## 6. Summary

Update after addressing comments,  
as applicable

Based on KLAND's understanding of the applicable City of Scottsdale criteria, requirements and design standards associated with drainage, it can be concluded that:

- The onsite storm drain system will be modeled using Haestad Methods, StormCAD v5.5 at the time of final design.
- The anticipated 100-year peak flows contributing to the storm drain inlets and building roof drains will be calculated using the Rational Method.
- The retention will be provided through both the surface basins and underground storage tanks for the anticipated runoff from the 100 year 2 hour storm event.
- The retention tank will be designed to dewater in less than 36 hours via drywells.
- The proposed conditions of the site do not significantly alter runoff pattern from the existing condition.
- Offsite flows are not impacting the site.
- The finish floor is set at 1 foot above the 100 year 2 hour retention high water.

## REFERENCES

1. Drainage Design Manual for Maricopa County, Arizona - Volume I Hydrology, Flood Control District of Maricopa County 2003
2. Drainage Design Manual for Maricopa County, Arizona - Volume II Hydraulics, Flood Control District of Maricopa County, 2003
3. Drainage Policies and Standards for Maricopa County, Arizona, Flood Control District of Maricopa County, 2007

# APPENDIX A

## FEMA Exhibit

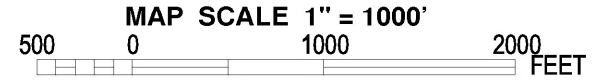

NATIONAL FLOOD INSURANCE PROGRAM

PANEL 1760L

**FIRM**  
**FLOOD INSURANCE RATE MAP**  
**MARICOPA COUNTY,**  
**ARIZONA**  
**AND INCORPORATED AREAS**

**PANEL 1760 OF 4425**

(SEE MAP INDEX FOR FIRM PANEL LAYOUT)

CONTAINS:

COMMUNITY	NUMBER	PANEL	SUFFIX
MARICOPA COUNTY	040037	1760	L
PARADISE VALLEY, TOWN OF	040049	1760	L
PHOENIX, CITY OF	040051	1760	L
SCOTTSDALE, CITY OF	045012	1760	L

Notice to User: The **Map Number** shown below should be used when placing map orders; the **Community Number** shown above should be used on insurance applications for the subject community.



**MAP NUMBER**  
**04013C1760L**

**MAP REVISED**  
**OCTOBER 16, 2013**

Federal Emergency Management Agency

This is an official copy of a portion of the above referenced flood map. It was extracted using F-MIT On-Line. This map does not reflect changes or amendments which may have been made subsequent to the date on the title block. For the latest product information about National Flood Insurance Program flood maps check the FEMA Flood Map Store at [www.msc.fema.gov](http://www.msc.fema.gov)

25-ZN-2018  
 25\_019\_07018213  
 12/15/2020

# APPENDIX B

## Drainage Calculations

Below is shown the impervious and pervious areas, plus the runoff coefficient factor for each type of area  
 We have calculated the total weighted runoff coefficient based on numbers below.

$$C = (C_p \times A_p + C_i \times A_i) \div (A_p + A_i)$$

$A_p = 112,810$  sft (Landscape and permeable surfaces)

$A_i = 209,680$  sft (Impermeable surfaces)

$C_p = 0.5$  (Landscape and permeable coefficient)

$C_i = 0.95$  (Impermeable runoff coefficient)

WEIGHTED C FACTOR BASED ON SURFACE TYPE		
Surface Type	C Factor	Area (sft)
Impervious	0.95	209680
pervious	0.5	112810
C Weighted	0.79	

total AREA	322490
impervios	209680
pervious	112810

Below is a summary of tributary areas that sum to the total site area. Also shown is the retention volume required for each area and volume provided in surface or underground retention basins.

RETENTION BASIN CALCULATIONS											
Sub-Area (onsite)	Area (sf)	Area (acre)	C100	P100 YR, 2 HR (in)	Vol. Req. (cf)	Surface Vol. Prov. (cf)	Total Tank Length Provided (LF)	Underground Vol. Prov. (cf)	Total Vol. Prov. (cf)	Excess Volume (%)	DRYWELLS
A	7,796.00	0.18	0.79	2.22	1,139.39	1,442.0	0.0	0.0	1,442.0	26.6	0
B	150,929	3.465	0.79	2.22	22,058.3	0.0	282.0	22,148.2	22,148.2	0.4	2
C	15,776	0.362	0.56	2.22	1,634.4	1,757.0	0.0	0.0	1,757.0	7.5	0
D	147,935	3.396	0.79	2.22	21,620.7	37,078.0	0.0	0.0	37,078.0	71.5	3
Total	314,640.0	7.4	-	-	46,452.8	40,277.0	282.0	22,148.2	62,425.2	34.4	5

<b>PROPOSED SURFACE BASINS INFORMATION</b>					
BASIN	HWE	BOT	VOL (P)	VOL (R)	TOTAL VOL (P)
A	80.6	79.6	1,442	1,139	1,442
C1	81.4	81.0	803	1,634	1,757
C2	82.5	82.0	106		
C3	82.6	82.1	848		
D	82.3	79.3	37,078	21,620	37,078

<b>EXISTING SURFACE BASIN INFORMATION</b>					
BASIN	HWE	BOT	VOL (P)	VOL (R)	TOTAL VOL (P)
D	82.3	80.2	17,602	30,400	17,602

What does this means ?

We have determined most critical inlets per engineering judgment and calculated Q100 for each sub-area.

<b>RATIONAL METHOD- MOST CRITICAL INLETS</b>						
INLET LABEL	Area (sf)	Area (acre)	C (weighted)	Tc (min)	i <sub>100</sub> (in/hr)	Q <sub>100</sub> (cfs)
A1	7,796	0.18	0.95	5	7.55	1.28
B1	14,712	0.34	0.95	5	7.55	2.42
B2	14,153	0.32	0.95	5	7.55	2.33
B3	18,213	0.42	0.95	5	7.55	3.00
B4	14,596	0.34	0.95	5	7.55	2.40
B5	11,496	0.26	0.95	5	7.55	1.89
B6	9,650	0.22	0.95	5	7.55	1.59
B7	28,434	0.65	0.95	5	7.55	4.68
B8	32,102	0.74	0.95	5	7.55	5.29
B9	7,560	0.17	0.95	5	7.55	1.24
C1	2,273	0.05	0.95	5	7.55	0.37

Q<sub>100</sub> = CIA

C = Runoff Coefficient

I = Rainfall Intensity for 10-minute time-of-concentration

A = Area is acres



**NOAA Atlas 14, Volume 1, Version 5**  
**Location name: Scottsdale, Arizona, USA\***  
**Latitude: 33.5885°, Longitude: -111.8902°**  
**Elevation: 1384.44 ft\*\***



\* source: ESRI Maps  
 \*\* source: USGS

**POINT PRECIPITATION FREQUENCY ESTIMATES**

Sanja Perica, Sarah Dietz, Sarah Heim, Lillian Hiner, Kazungu Maitaria, Deborah Martin, Sandra Pavlovic, Ishani Roy, Carl Trypaluk, Dale Unruh, Fenglin Yan, Michael Yekta, Tan Zhao, Geoffrey Bonnin, Daniel Brewer, Li-Chuan Chen, Tye Parzybok, John Yarchoan

NOAA, National Weather Service, Silver Spring, Maryland

[PF\\_tabular](#) | [PF\\_graphical](#) | [Maps\\_&\\_aerials](#)

**PF tabular**

<b>PDS-based point precipitation frequency estimates with 90% confidence intervals (in inches)<sup>1</sup></b>										
<b>Duration</b>	<b>Average recurrence interval (years)</b>									
	<b>1</b>	<b>2</b>	<b>5</b>	<b>10</b>	<b>25</b>	<b>50</b>	<b>100</b>	<b>200</b>	<b>500</b>	<b>1000</b>
<b>5-min</b>	<b>0.189</b> (0.157-0.231)	<b>0.246</b> (0.206-0.302)	<b>0.332</b> (0.275-0.406)	<b>0.399</b> (0.329-0.486)	<b>0.489</b> (0.396-0.593)	<b>0.558</b> (0.447-0.672)	<b>0.629</b> (0.495-0.756)	<b>0.700</b> (0.542-0.840)	<b>0.797</b> (0.601-0.957)	<b>0.870</b> (0.643-1.05)
<b>10-min</b>	<b>0.287</b> (0.238-0.351)	<b>0.375</b> (0.313-0.459)	<b>0.506</b> (0.419-0.618)	<b>0.607</b> (0.501-0.739)	<b>0.744</b> (0.603-0.903)	<b>0.849</b> (0.681-1.02)	<b>0.957</b> (0.754-1.15)	<b>1.07</b> (0.825-1.28)	<b>1.21</b> (0.915-1.46)	<b>1.33</b> (0.979-1.59)
<b>15-min</b>	<b>0.356</b> (0.295-0.436)	<b>0.464</b> (0.388-0.569)	<b>0.627</b> (0.519-0.766)	<b>0.753</b> (0.621-0.917)	<b>0.922</b> (0.748-1.12)	<b>1.05</b> (0.844-1.27)	<b>1.19</b> (0.935-1.43)	<b>1.32</b> (1.02-1.59)	<b>1.50</b> (1.13-1.81)	<b>1.64</b> (1.21-1.97)
<b>30-min</b>	<b>0.479</b> (0.397-0.587)	<b>0.625</b> (0.523-0.767)	<b>0.844</b> (0.699-1.03)	<b>1.01</b> (0.836-1.23)	<b>1.24</b> (1.01-1.51)	<b>1.42</b> (1.14-1.71)	<b>1.60</b> (1.26-1.92)	<b>1.78</b> (1.38-2.13)	<b>2.03</b> (1.53-2.43)	<b>2.21</b> (1.64-2.66)
<b>60-min</b>	<b>0.593</b> (0.492-0.726)	<b>0.774</b> (0.647-0.949)	<b>1.05</b> (0.865-1.28)	<b>1.25</b> (1.03-1.53)	<b>1.54</b> (1.25-1.87)	<b>1.75</b> (1.41-2.11)	<b>1.98</b> (1.56-2.38)	<b>2.20</b> (1.70-2.64)	<b>2.51</b> (1.89-3.01)	<b>2.74</b> (2.02-3.29)
<b>2-hr</b>	<b>0.694</b> (0.584-0.830)	<b>0.897</b> (0.759-1.08)	<b>1.20</b> (1.00-1.43)	<b>1.42</b> (1.18-1.70)	<b>1.74</b> (1.43-2.06)	<b>1.97</b> (1.60-2.33)	<b>2.22</b> (1.77-2.61)	<b>2.46</b> (1.94-2.90)	<b>2.80</b> (2.15-3.30)	<b>3.06</b> (2.29-3.62)
<b>3-hr</b>	<b>0.772</b> (0.650-0.945)	<b>0.989</b> (0.836-1.22)	<b>1.29</b> (1.09-1.58)	<b>1.53</b> (1.27-1.86)	<b>1.87</b> (1.53-2.26)	<b>2.14</b> (1.73-2.57)	<b>2.42</b> (1.92-2.90)	<b>2.71</b> (2.11-3.24)	<b>3.11</b> (2.36-3.72)	<b>3.44</b> (2.54-4.12)
<b>6-hr</b>	<b>0.930</b> (0.798-1.11)	<b>1.17</b> (1.01-1.40)	<b>1.50</b> (1.28-1.77)	<b>1.76</b> (1.49-2.07)	<b>2.11</b> (1.76-2.48)	<b>2.39</b> (1.96-2.79)	<b>2.68</b> (2.17-3.12)	<b>2.97</b> (2.36-3.47)	<b>3.37</b> (2.61-3.93)	<b>3.68</b> (2.79-4.31)
<b>12-hr</b>	<b>1.03</b> (0.891-1.22)	<b>1.30</b> (1.12-1.53)	<b>1.64</b> (1.41-1.93)	<b>1.91</b> (1.63-2.23)	<b>2.27</b> (1.92-2.65)	<b>2.55</b> (2.13-2.97)	<b>2.84</b> (2.33-3.30)	<b>3.13</b> (2.54-3.63)	<b>3.51</b> (2.78-4.10)	<b>3.81</b> (2.96-4.48)
<b>24-hr</b>	<b>1.21</b> (1.06-1.39)	<b>1.53</b> (1.35-1.77)	<b>1.97</b> (1.73-2.28)	<b>2.32</b> (2.03-2.68)	<b>2.81</b> (2.44-3.23)	<b>3.20</b> (2.75-3.67)	<b>3.60</b> (3.07-4.13)	<b>4.01</b> (3.39-4.60)	<b>4.59</b> (3.82-5.26)	<b>5.04</b> (4.15-5.80)
<b>2-day</b>	<b>1.30</b> (1.13-1.49)	<b>1.65</b> (1.45-1.91)	<b>2.16</b> (1.89-2.49)	<b>2.57</b> (2.23-2.95)	<b>3.13</b> (2.70-3.59)	<b>3.57</b> (3.06-4.10)	<b>4.04</b> (3.44-4.64)	<b>4.53</b> (3.82-5.21)	<b>5.21</b> (4.33-6.00)	<b>5.75</b> (4.71-6.64)
<b>3-day</b>	<b>1.39</b> (1.22-1.59)	<b>1.77</b> (1.56-2.04)	<b>2.33</b> (2.04-2.67)	<b>2.78</b> (2.43-3.18)	<b>3.41</b> (2.96-3.90)	<b>3.92</b> (3.37-4.47)	<b>4.45</b> (3.81-5.09)	<b>5.01</b> (4.25-5.74)	<b>5.81</b> (4.85-6.65)	<b>6.45</b> (5.33-7.41)
<b>4-day</b>	<b>1.48</b> (1.31-1.69)	<b>1.89</b> (1.67-2.17)	<b>2.50</b> (2.20-2.85)	<b>2.99</b> (2.62-3.41)	<b>3.69</b> (3.22-4.20)	<b>4.26</b> (3.68-4.84)	<b>4.86</b> (4.18-5.53)	<b>5.50</b> (4.68-6.27)	<b>6.41</b> (5.38-7.30)	<b>7.15</b> (5.94-8.17)
<b>7-day</b>	<b>1.66</b> (1.46-1.91)	<b>2.13</b> (1.86-2.44)	<b>2.82</b> (2.46-3.23)	<b>3.37</b> (2.94-3.87)	<b>4.16</b> (3.60-4.76)	<b>4.80</b> (4.13-5.48)	<b>5.48</b> (4.68-6.26)	<b>6.20</b> (5.25-7.11)	<b>7.23</b> (6.04-8.28)	<b>8.05</b> (6.66-9.25)
<b>10-day</b>	<b>1.80</b> (1.58-2.06)	<b>2.30</b> (2.02-2.63)	<b>3.04</b> (2.67-3.47)	<b>3.64</b> (3.18-4.15)	<b>4.47</b> (3.89-5.09)	<b>5.15</b> (4.45-5.84)	<b>5.86</b> (5.03-6.66)	<b>6.61</b> (5.63-7.53)	<b>7.67</b> (6.45-8.73)	<b>8.52</b> (7.09-9.72)
<b>20-day</b>	<b>2.22</b> (1.96-2.53)	<b>2.86</b> (2.52-3.25)	<b>3.78</b> (3.32-4.29)	<b>4.47</b> (3.92-5.07)	<b>5.41</b> (4.73-6.13)	<b>6.13</b> (5.34-6.95)	<b>6.87</b> (5.95-7.80)	<b>7.62</b> (6.56-8.66)	<b>8.63</b> (7.37-9.84)	<b>9.41</b> (7.97-10.7)
<b>30-day</b>	<b>2.60</b> (2.29-2.96)	<b>3.35</b> (2.95-3.80)	<b>4.42</b> (3.89-5.01)	<b>5.23</b> (4.59-5.92)	<b>6.32</b> (5.53-7.15)	<b>7.16</b> (6.24-8.10)	<b>8.03</b> (6.96-9.07)	<b>8.91</b> (7.67-10.1)	<b>10.1</b> (8.62-11.4)	<b>11.0</b> (9.33-12.5)
<b>45-day</b>	<b>3.02</b> (2.67-3.42)	<b>3.89</b> (3.44-4.40)	<b>5.13</b> (4.53-5.80)	<b>6.05</b> (5.33-6.84)	<b>7.26</b> (6.38-8.21)	<b>8.18</b> (7.16-9.24)	<b>9.10</b> (7.93-10.3)	<b>10.0</b> (8.69-11.4)	<b>11.3</b> (9.68-12.8)	<b>12.2</b> (10.4-13.9)
<b>60-day</b>	<b>3.33</b> (2.97-3.76)	<b>4.31</b> (3.83-4.87)	<b>5.67</b> (5.03-6.39)	<b>6.67</b> (5.90-7.51)	<b>7.96</b> (7.02-8.97)	<b>8.92</b> (7.84-10.1)	<b>9.88</b> (8.64-11.1)	<b>10.8</b> (9.43-12.2)	<b>12.1</b> (10.4-13.7)	<b>13.0</b> (11.2-14.8)

<sup>1</sup> Precipitation frequency (PF) estimates in this table are based on frequency analysis of partial duration series (PDS). Numbers in parenthesis are PF estimates at lower and upper bounds of the 90% confidence interval. The probability that precipitation frequency estimates (for a given duration and average recurrence interval) will be greater than the upper bound (or less than the lower bound) is 5%. Estimates at upper bounds are not checked against probable maximum precipitation (PMP) estimates and may be higher than currently valid PMP values. Please refer to NOAA Atlas 14 document for more information.

[Back to Top](#)

### PF graphical

PDS-based depth-duration-frequency (DDF) curves  
Latitude: 33.5885°, Longitude: -111.8902°

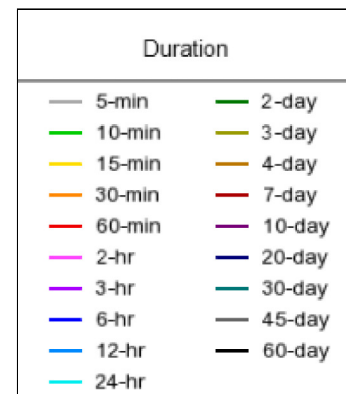
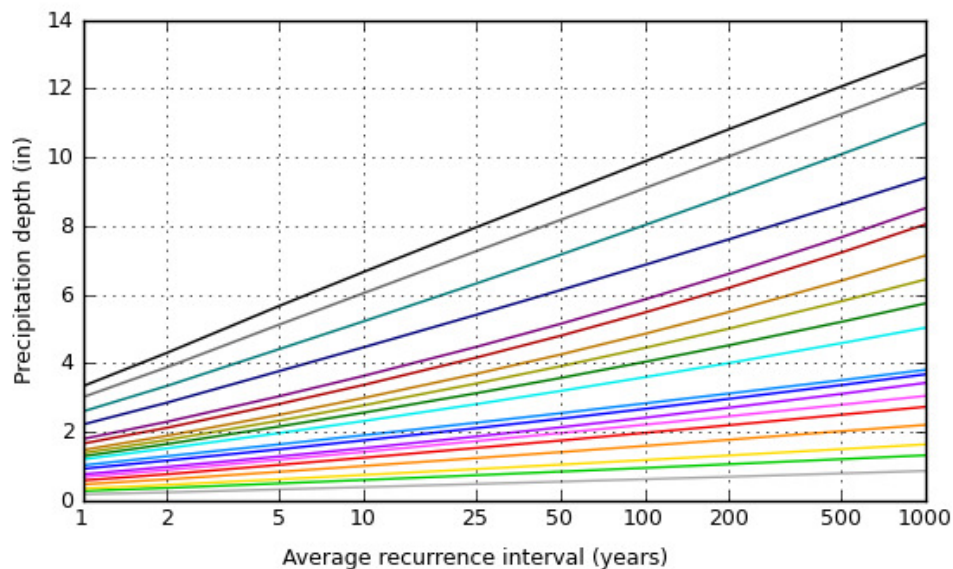
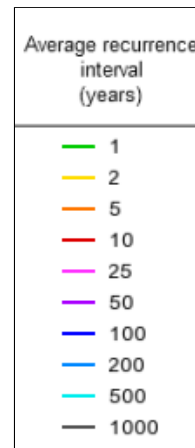
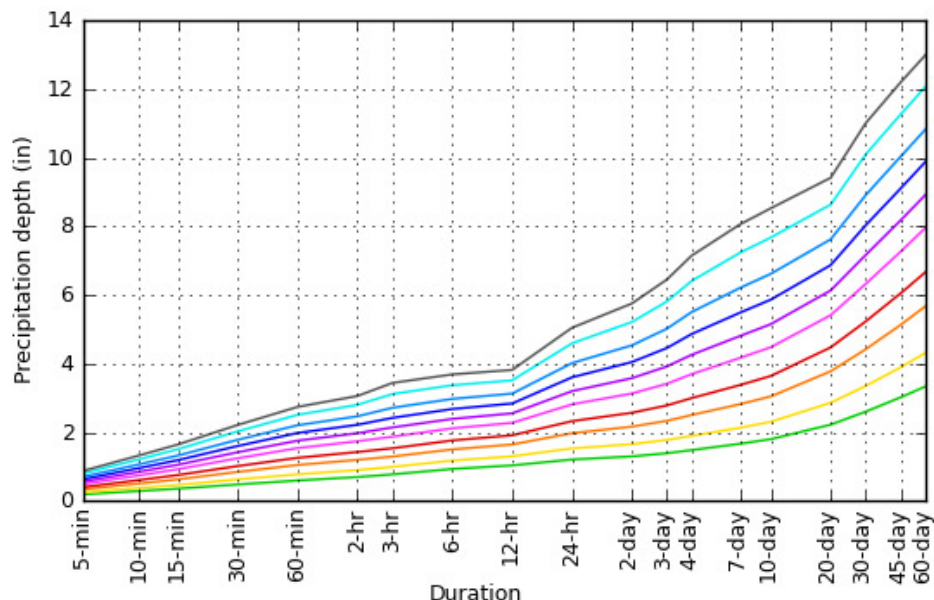

[Back to Top](#)

### Maps & aerials

Small scale terrain



Large scale terrain



Large scale map



Large scale aerial



[Back to Top](#)

---

[US Department of Commerce](#)  
[National Oceanic and Atmospheric Administration](#)  
[National Weather Service](#)  
[National Water Center](#)  
1325 East West Highway  
Silver Spring, MD 20910  
Questions?: [HDSC.Questions@noaa.gov](mailto:HDSC.Questions@noaa.gov)

[Disclaimer](#)



**NOAA Atlas 14, Volume 1, Version 5**  
**Location name: Scottsdale, Arizona, USA\***  
**Latitude: 33.5885°, Longitude: -111.8902°**  
**Elevation: 1384.44 ft\*\***



\* source: ESRI Maps  
 \*\* source: USGS

**POINT PRECIPITATION FREQUENCY ESTIMATES**

Sanja Perica, Sarah Dietz, Sarah Heim, Lillian Hiner, Kazungu Maitaria, Deborah Martin, Sandra Pavlovic, Ishani Roy, Carl Trypaluk, Dale Unruh, Fenglin Yan, Michael Yekta, Tan Zhao, Geoffrey Bonnin, Daniel Brewer, Li-Chuan Chen, Tye Parzybok, John Yarchoan

NOAA, National Weather Service, Silver Spring, Maryland

[PF\\_tabular](#) | [PF\\_graphical](#) | [Maps\\_&\\_aerials](#)

**PF tabular**

<b>PDS-based point precipitation frequency estimates with 90% confidence intervals (in inches/hour)<sup>1</sup></b>										
<b>Duration</b>	<b>Average recurrence interval (years)</b>									
	<b>1</b>	<b>2</b>	<b>5</b>	<b>10</b>	<b>25</b>	<b>50</b>	<b>100</b>	<b>200</b>	<b>500</b>	<b>1000</b>
<b>5-min</b>	<b>2.27</b> (1.88-2.77)	<b>2.95</b> (2.47-3.62)	<b>3.98</b> (3.30-4.87)	<b>4.79</b> (3.95-5.83)	<b>5.87</b> (4.75-7.12)	<b>6.70</b> (5.36-8.06)	<b>7.55</b> (5.94-9.07)	<b>8.40</b> (6.50-10.1)	<b>9.56</b> (7.21-11.5)	<b>10.4</b> (7.72-12.6)
<b>10-min</b>	<b>1.72</b> (1.43-2.11)	<b>2.25</b> (1.88-2.75)	<b>3.04</b> (2.51-3.71)	<b>3.64</b> (3.01-4.43)	<b>4.46</b> (3.62-5.42)	<b>5.09</b> (4.09-6.13)	<b>5.74</b> (4.52-6.91)	<b>6.40</b> (4.95-7.67)	<b>7.28</b> (5.49-8.74)	<b>7.95</b> (5.87-9.56)
<b>15-min</b>	<b>1.42</b> (1.18-1.74)	<b>1.86</b> (1.55-2.28)	<b>2.51</b> (2.08-3.06)	<b>3.01</b> (2.48-3.67)	<b>3.69</b> (2.99-4.48)	<b>4.21</b> (3.38-5.07)	<b>4.75</b> (3.74-5.71)	<b>5.28</b> (4.09-6.34)	<b>6.02</b> (4.54-7.22)	<b>6.57</b> (4.86-7.90)
<b>30-min</b>	<b>0.958</b> (0.794-1.17)	<b>1.25</b> (1.05-1.53)	<b>1.69</b> (1.40-2.06)	<b>2.03</b> (1.67-2.47)	<b>2.48</b> (2.01-3.01)	<b>2.83</b> (2.27-3.41)	<b>3.20</b> (2.52-3.84)	<b>3.56</b> (2.75-4.27)	<b>4.05</b> (3.05-4.86)	<b>4.42</b> (3.27-5.32)
<b>60-min</b>	<b>0.593</b> (0.492-0.726)	<b>0.774</b> (0.647-0.949)	<b>1.05</b> (0.865-1.28)	<b>1.25</b> (1.03-1.53)	<b>1.54</b> (1.25-1.87)	<b>1.75</b> (1.41-2.11)	<b>1.98</b> (1.56-2.38)	<b>2.20</b> (1.70-2.64)	<b>2.51</b> (1.89-3.01)	<b>2.74</b> (2.02-3.29)
<b>2-hr</b>	<b>0.347</b> (0.292-0.415)	<b>0.448</b> (0.380-0.538)	<b>0.598</b> (0.502-0.713)	<b>0.712</b> (0.592-0.848)	<b>0.868</b> (0.716-1.03)	<b>0.986</b> (0.802-1.17)	<b>1.11</b> (0.886-1.31)	<b>1.23</b> (0.968-1.45)	<b>1.40</b> (1.07-1.65)	<b>1.53</b> (1.15-1.81)
<b>3-hr</b>	<b>0.257</b> (0.216-0.315)	<b>0.329</b> (0.278-0.405)	<b>0.430</b> (0.362-0.526)	<b>0.510</b> (0.425-0.620)	<b>0.623</b> (0.510-0.752)	<b>0.712</b> (0.576-0.855)	<b>0.805</b> (0.639-0.966)	<b>0.903</b> (0.704-1.08)	<b>1.04</b> (0.784-1.24)	<b>1.14</b> (0.845-1.37)
<b>6-hr</b>	<b>0.155</b> (0.133-0.185)	<b>0.196</b> (0.168-0.233)	<b>0.250</b> (0.213-0.296)	<b>0.294</b> (0.248-0.346)	<b>0.353</b> (0.294-0.414)	<b>0.399</b> (0.327-0.466)	<b>0.447</b> (0.362-0.520)	<b>0.496</b> (0.394-0.579)	<b>0.563</b> (0.435-0.656)	<b>0.615</b> (0.465-0.719)
<b>12-hr</b>	<b>0.086</b> (0.074-0.101)	<b>0.108</b> (0.093-0.127)	<b>0.136</b> (0.117-0.160)	<b>0.159</b> (0.135-0.185)	<b>0.189</b> (0.159-0.220)	<b>0.212</b> (0.176-0.246)	<b>0.235</b> (0.193-0.273)	<b>0.259</b> (0.210-0.301)	<b>0.291</b> (0.230-0.340)	<b>0.317</b> (0.246-0.372)
<b>24-hr</b>	<b>0.050</b> (0.044-0.058)	<b>0.064</b> (0.056-0.074)	<b>0.082</b> (0.072-0.095)	<b>0.097</b> (0.085-0.112)	<b>0.117</b> (0.102-0.135)	<b>0.133</b> (0.115-0.153)	<b>0.150</b> (0.128-0.172)	<b>0.167</b> (0.141-0.192)	<b>0.191</b> (0.159-0.219)	<b>0.210</b> (0.173-0.242)
<b>2-day</b>	<b>0.027</b> (0.024-0.031)	<b>0.034</b> (0.030-0.040)	<b>0.045</b> (0.039-0.052)	<b>0.053</b> (0.046-0.061)	<b>0.065</b> (0.056-0.075)	<b>0.074</b> (0.064-0.085)	<b>0.084</b> (0.072-0.097)	<b>0.094</b> (0.080-0.109)	<b>0.109</b> (0.090-0.125)	<b>0.120</b> (0.098-0.138)
<b>3-day</b>	<b>0.019</b> (0.017-0.022)	<b>0.025</b> (0.022-0.028)	<b>0.032</b> (0.028-0.037)	<b>0.039</b> (0.034-0.044)	<b>0.047</b> (0.041-0.054)	<b>0.054</b> (0.047-0.062)	<b>0.062</b> (0.053-0.071)	<b>0.070</b> (0.059-0.080)	<b>0.081</b> (0.067-0.092)	<b>0.090</b> (0.074-0.103)
<b>4-day</b>	<b>0.015</b> (0.014-0.018)	<b>0.020</b> (0.017-0.023)	<b>0.026</b> (0.023-0.030)	<b>0.031</b> (0.027-0.036)	<b>0.038</b> (0.033-0.044)	<b>0.044</b> (0.038-0.050)	<b>0.051</b> (0.043-0.058)	<b>0.057</b> (0.049-0.065)	<b>0.067</b> (0.056-0.076)	<b>0.074</b> (0.062-0.085)
<b>7-day</b>	<b>0.010</b> (0.009-0.011)	<b>0.013</b> (0.011-0.015)	<b>0.017</b> (0.015-0.019)	<b>0.020</b> (0.017-0.023)	<b>0.025</b> (0.021-0.028)	<b>0.029</b> (0.025-0.033)	<b>0.033</b> (0.028-0.037)	<b>0.037</b> (0.031-0.042)	<b>0.043</b> (0.036-0.049)	<b>0.048</b> (0.040-0.055)
<b>10-day</b>	<b>0.007</b> (0.007-0.009)	<b>0.010</b> (0.008-0.011)	<b>0.013</b> (0.011-0.014)	<b>0.015</b> (0.013-0.017)	<b>0.019</b> (0.016-0.021)	<b>0.021</b> (0.019-0.024)	<b>0.024</b> (0.021-0.028)	<b>0.028</b> (0.023-0.031)	<b>0.032</b> (0.027-0.036)	<b>0.036</b> (0.030-0.041)
<b>20-day</b>	<b>0.005</b> (0.004-0.005)	<b>0.006</b> (0.005-0.007)	<b>0.008</b> (0.007-0.009)	<b>0.009</b> (0.008-0.011)	<b>0.011</b> (0.010-0.013)	<b>0.013</b> (0.011-0.014)	<b>0.014</b> (0.012-0.016)	<b>0.016</b> (0.014-0.018)	<b>0.018</b> (0.015-0.020)	<b>0.020</b> (0.017-0.022)
<b>30-day</b>	<b>0.004</b> (0.003-0.004)	<b>0.005</b> (0.004-0.005)	<b>0.006</b> (0.005-0.007)	<b>0.007</b> (0.006-0.008)	<b>0.009</b> (0.008-0.010)	<b>0.010</b> (0.009-0.011)	<b>0.011</b> (0.010-0.013)	<b>0.012</b> (0.011-0.014)	<b>0.014</b> (0.012-0.016)	<b>0.015</b> (0.013-0.017)
<b>45-day</b>	<b>0.003</b> (0.002-0.003)	<b>0.004</b> (0.003-0.004)	<b>0.005</b> (0.004-0.005)	<b>0.006</b> (0.005-0.006)	<b>0.007</b> (0.006-0.008)	<b>0.008</b> (0.007-0.009)	<b>0.008</b> (0.007-0.010)	<b>0.009</b> (0.008-0.011)	<b>0.010</b> (0.009-0.012)	<b>0.011</b> (0.010-0.013)
<b>60-day</b>	<b>0.002</b> (0.002-0.003)	<b>0.003</b> (0.003-0.003)	<b>0.004</b> (0.003-0.004)	<b>0.005</b> (0.004-0.005)	<b>0.006</b> (0.005-0.006)	<b>0.006</b> (0.005-0.007)	<b>0.007</b> (0.006-0.008)	<b>0.008</b> (0.007-0.008)	<b>0.008</b> (0.007-0.010)	<b>0.009</b> (0.008-0.010)

<sup>1</sup> Precipitation frequency (PF) estimates in this table are based on frequency analysis of partial duration series (PDS). Numbers in parenthesis are PF estimates at lower and upper bounds of the 90% confidence interval. The probability that precipitation frequency estimates (for a given duration and average recurrence interval) will be greater than the upper bound (or less than the lower bound) is 5%. Estimates at upper bounds are not checked against probable maximum precipitation (PMP) estimates and may be higher than currently valid PMP values. Please refer to NOAA Atlas 14 document for more information.

[Back to Top](#)

### PF graphical

#### PDS-based intensity-duration-frequency (IDF) curves

Latitude: 33.5885°, Longitude: -111.8902°

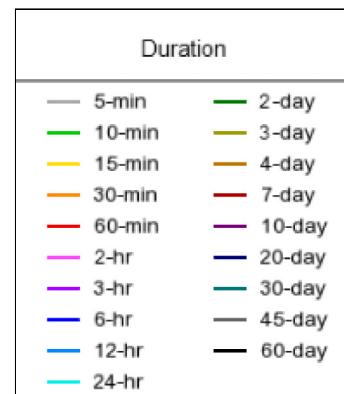
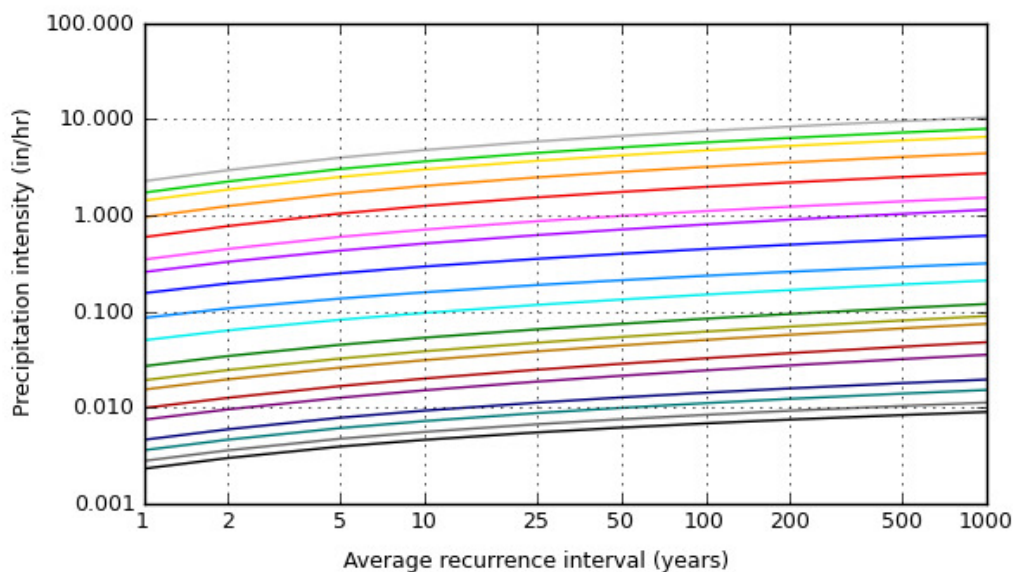
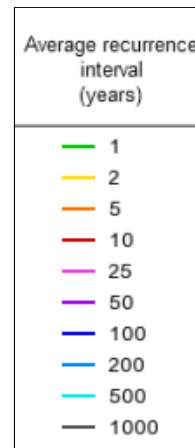
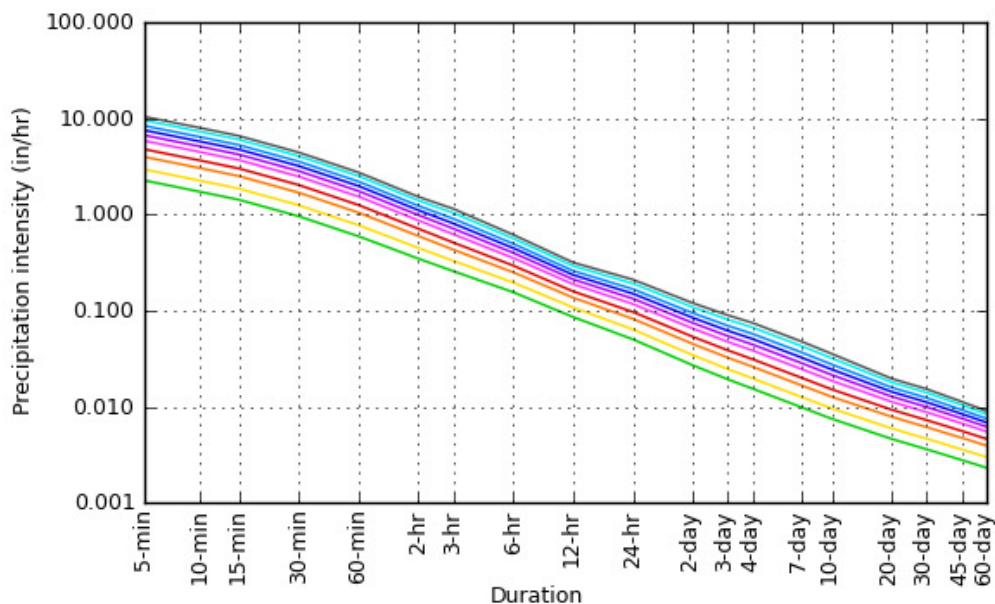

[Back to Top](#)

### Maps & aerials

Small scale terrain

# APPENDIX C

## Drainage Channel Report and ADOT Plans

F.A.R.A. REGION	STATE	PROJECT NO.	SHEET NO.	TOTAL SHEETS	AS BUILT
9	ARZ.	600-1-544	436	1950	03-11-02 DLM
101L MA 036					

Site

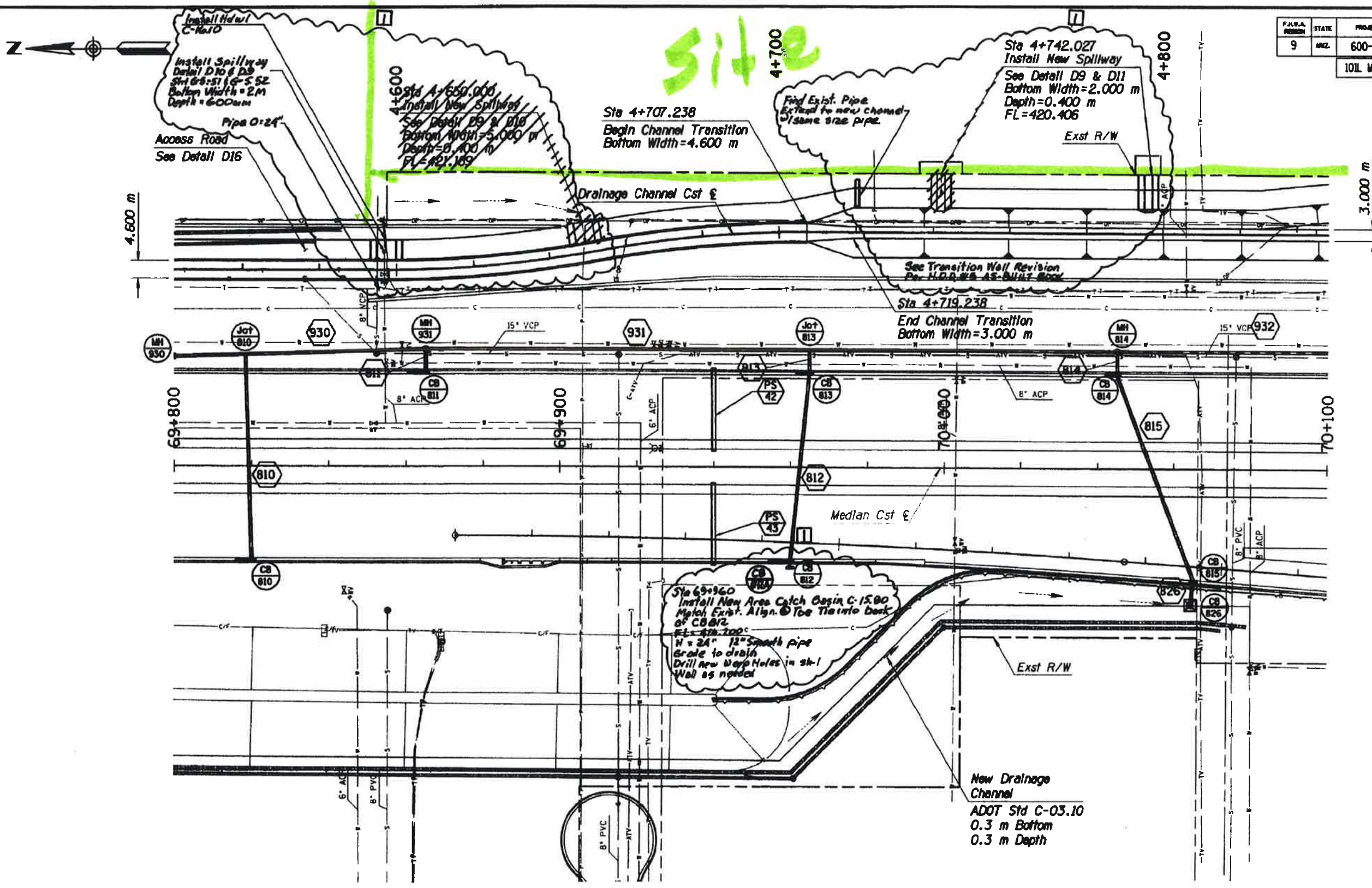

Install Spillway  
Detail D10 & D8  
Sta 68+51 to 68+52  
Bottom Width = 2.0 m  
Depth = 600 mm

Sta 4+660.000  
+ Install New Spillway  
See Detail D9 & D10  
Bottom Width = 5.000 m  
Depth = 0.400 m  
FL = 421.109

Sta 4+707.238  
Begin Channel Transition  
Bottom Width = 4.600 m

Sta 4+742.027  
Install New Spillway  
See Detail D9 & D11  
Bottom Width = 2.000 m  
Depth = 0.400 m  
FL = 420.406

Sta 4+719.238  
End Channel Transition  
Bottom Width = 3.000 m

Sta 69+960  
Install New Area Catch Basin C-15.00  
Match Exst. Align. @ Toe Tie into bank  
of CB 812  
FL = 418.200  
H = 24\"/>

New Drainage Channel  
ADOT Std C-03.10  
0.3 m Bottom  
0.3 m Depth

VIEW NAME:

DATE	
LOCATION	
BY	VLAS/MLT
CHECKED	
DATE	



DESIGN	RSR, RLH	DATE	4/98	ARIZONA DEPARTMENT OF TRANSPORTATION INTERMODAL TRANSPORTATION DIVISION
DRAWN	AEL	DATE	4/98	
CHECKED	JPM, ACP	DATE	4/98	WOOD, PATEL & ASSOCIATES, INC. 1550 EAST MISSOURI, SUITE 203 PHOENIX, ARIZONA 16021234-1544
ROUTE				
101L	LOCATION	PIMA FREEWAY - PIMA TO SHEA		DWG NO. D-1.22
TRACS NO. H 4083 OIC		600-1-544		436 OF 1350

FILE: V:\960711\95SUB\DRPLANIG.DGN  
DATE: 04/23/98



F.A.R.A. REGION	STATE	PROJECT NO.	SHEET NO.	TOTAL SHEETS	AS BUILT
9	ARIZ.	600-1-544	448	1890	03.11.02 DLW

101L MA 036

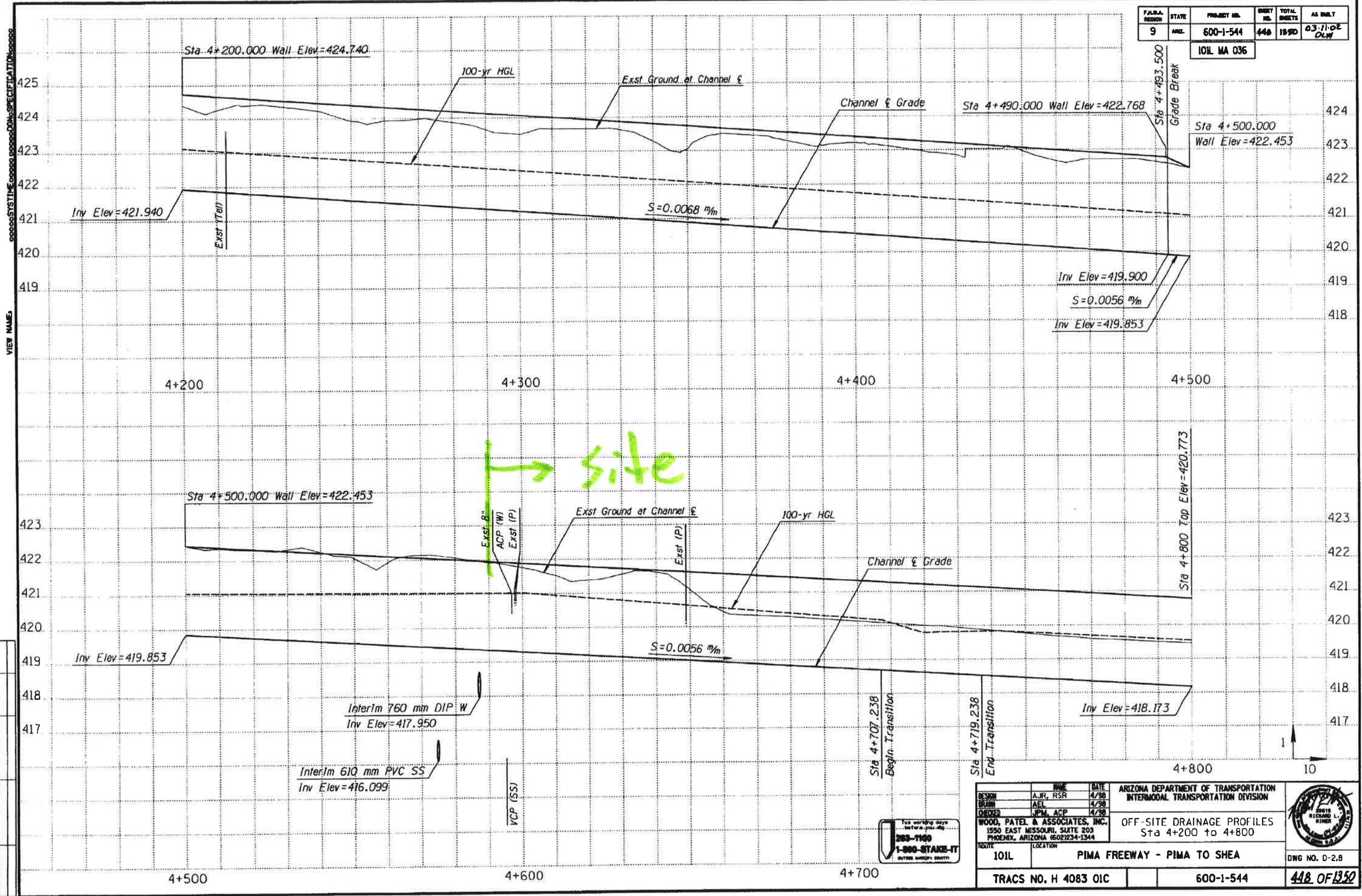

→ site

DATE	
LOCATION	
REVISION	
BY	
CHECKED	
DATE	

DESIGN	AJR, RSR	DATE	4/98	ARIZONA DEPARTMENT OF TRANSPORTATION INTERMODAL TRANSPORTATION DIVISION  OFF-SITE DRAINAGE PROFILES Sta 4+200 to 4+800
DRAWN	AEL	DATE	4/98	
CHECKED	JPM, ACP	DATE	4/98	
WOOD, PATEL & ASSOCIATES, INC. 1550 EAST MISSOURI, SUITE 203 PHOENIX, ARIZONA 85022-3414				
ROUTE	101L	LOCATION	PIMA FREEWAY - PIMA TO SHEA	DWG NO. D-2.8
TRACS NO. H 4083 OIC		600-1-544		448 OF 1350



FILE: v:\960711\95sub\chpr f08.dgn  
DATE: 04/23/98 13:00

F.A.B.A. PERSON	STATE	PROJECT NO.	SHEET NO.	TOTAL SHEETS	AS BUILT
9	ARZ.	600-1-544	449	1980	03-11-02 DLW
IOIL MA 036					

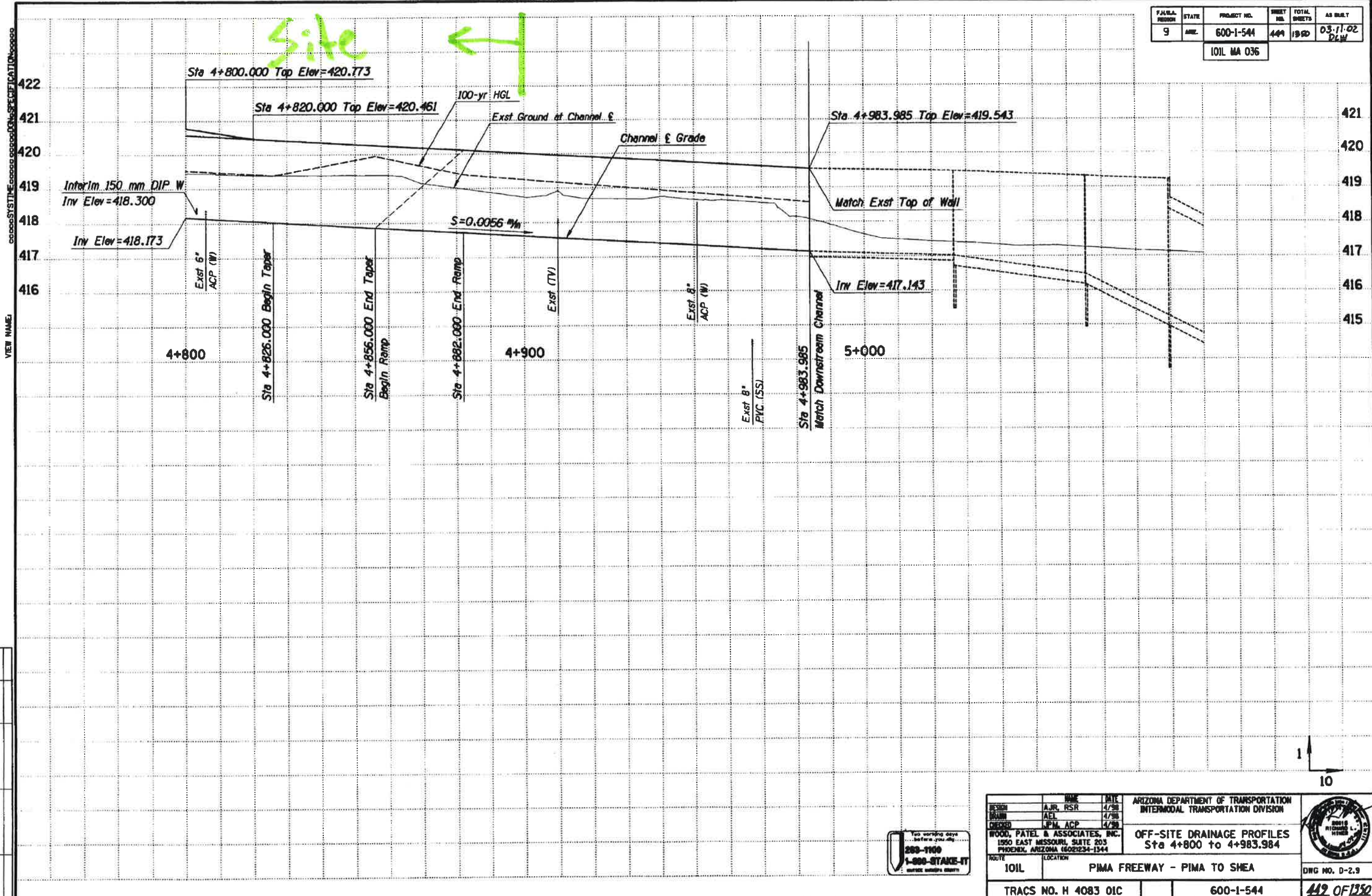

Site ←

DATE	
LOCATION	
REVISION	
BY	
CHECKED	
DATE	



DESIGN	AJR, RSR	DATE	4/98
DRAWN	AEL	DATE	4/98
CHECKED	JPM, ACP	DATE	4/98
WOOD, PATEL & ASSOCIATES, INC. 1950 EAST MISSOURI, SUITE 203 PHOENIX, ARIZONA 85024-2344			
ROUTE		LOCATION	
IOIL		PIMA FREEWAY - PIMA TO SHEA	
TRACS NO. H 4083 OIC		600-1-544	
		DWG NO. D-2.9	
		449 OF 1350	



Metric

**SPEEDIE  
AND ASSOCIATES**  
GEOTECHNICAL AND SITE ENGINEERS  
11020 N. 24th AVENUE, SUITE 905 • PHOENIX, ARIZONA 85028 • (602) 997-6361

DRAINAGE REPORT



DESIGNATION: Armenian Apostolic Church  
LOCATION: Pima Road & Cholla Avenue  
CLIENT: Armenian Apostolic Church  
PROJECT NO: 880199CA  
DATE: October 27, 1989

001509

TABLE OF CONTENTS

	<u>PAGE</u>
PROJECT LOCATION & DESCRIPTION OF SITE .....	1
OFFSITE DRAINAGE .....	1
ONSITE DRAINAGE .....	2
EXHIBIT A - Location Map .....	3
EXHIBIT B - Topographic Map .....	4
EXHIBIT C - Hydrologic Design Data Sheet .....	5
EXHIBIT D - Drainage Ditch Calculations .....	6
EXHIBIT E - Retention Volume Calculations .....	7

**SPEEDIE  
AND ASSOCIATES**  
GEOTECHNICAL AND SITE ENGINEERS  
11029 N. 24th AVE., SUITE 805 • PHOENIX, ARIZONA, 85029

**PROJECT LOCATION & DESCRIPTION OF SITE:**

The proposed church site is located in the Northwest 1/4 of the Southwest 1/4 of Section 19, Township 3 North, Range 5 East of the Gila and Salt River Base and Meridian, Maricopa County, Arizona. The site is located within the city limits of Scottsdale, Arizona, south and east of where the Cholla Drive alignment intersects Pima Road from the east. The area of the site is approximately 3.0 acres (see Exhibit A).

The subject site slopes generally towards the southwest and contains, as a main drainage feature, a natural wash approximately 18 inches deep, and 20 feet wide which runs across the site from the northeast corner to the southwest corner and continues to the south.

There are no existing structures on the site. Vegetation on the site is at present desert brush with 15 percent density. The soil type is class "B", based upon the SCS map provided in the City of Scottsdale Publication "Drainage Report Preparation", Figure 2-14.

**OFFSITE DRAINAGE:**

Runoff flows into the wash at the northeast corner of the site where the south end of 88th Place intersects Cholla Drive. The northern limits of the contributing drainage area is considered to be Jenan Drive, approximately 2,100 feet north of the subject property.

Based on the drainage report for the Ricco Villas #2 subdivision which is to the north of the subject site, the drainage area contributing runoff to the wash was to be 21 acres with a drainage length of 1,700 feet (sub area 1b, Ricco Villas #2 Drainage Report). However, the subdivision as constructed varies somewhat from the original preliminary plat which was the basis for design. The drainage area is now considered to be 26 acres with a drainage length of 2,100 feet. The rational method was used for hydrology calculations for a 100-year and 10-year design frequency (see Exhibits B & C).

001501

001502

**SPEEDIE  
AND ASSOCIATES**  
GEOTECHNICAL / MATERIALS / SITE ENGINEERS  
11729 N 24th AVE. SUITE 805 • PHOENIX, ARIZONA 85029

PROJECT NO: 880199CA

PAGE 2 OF 2

Present plans for the church site call for the construction of a drainage ditch along the north 16.5 feet of the site which will channel runoff now entering the site from the north towards the west where it will flow into the existing drainage ditch along the east side of Pima Road (see Exhibit D). The west 40 feet of the site is reserved for a drainageway to be installed with the future highway improvements along the Pima Road alignment.

ONSITE DRAINAGE:

A detention basin is to be constructed on the site to retain runoff generated from the proposed development. Total retention volume required for the site is 17,719 cubic feet (see Calculation - Exhibit E). This volume is provided in the proposed basin at a depth of less than two feet. The retained runoff is to be metered into the drainage ditch along Pima Road through a 12-inch pipe (see Grading & Drainage Plan). The maximum level to which water can pond is one foot below the building finish floor.

10.29-A

0015002

0015003

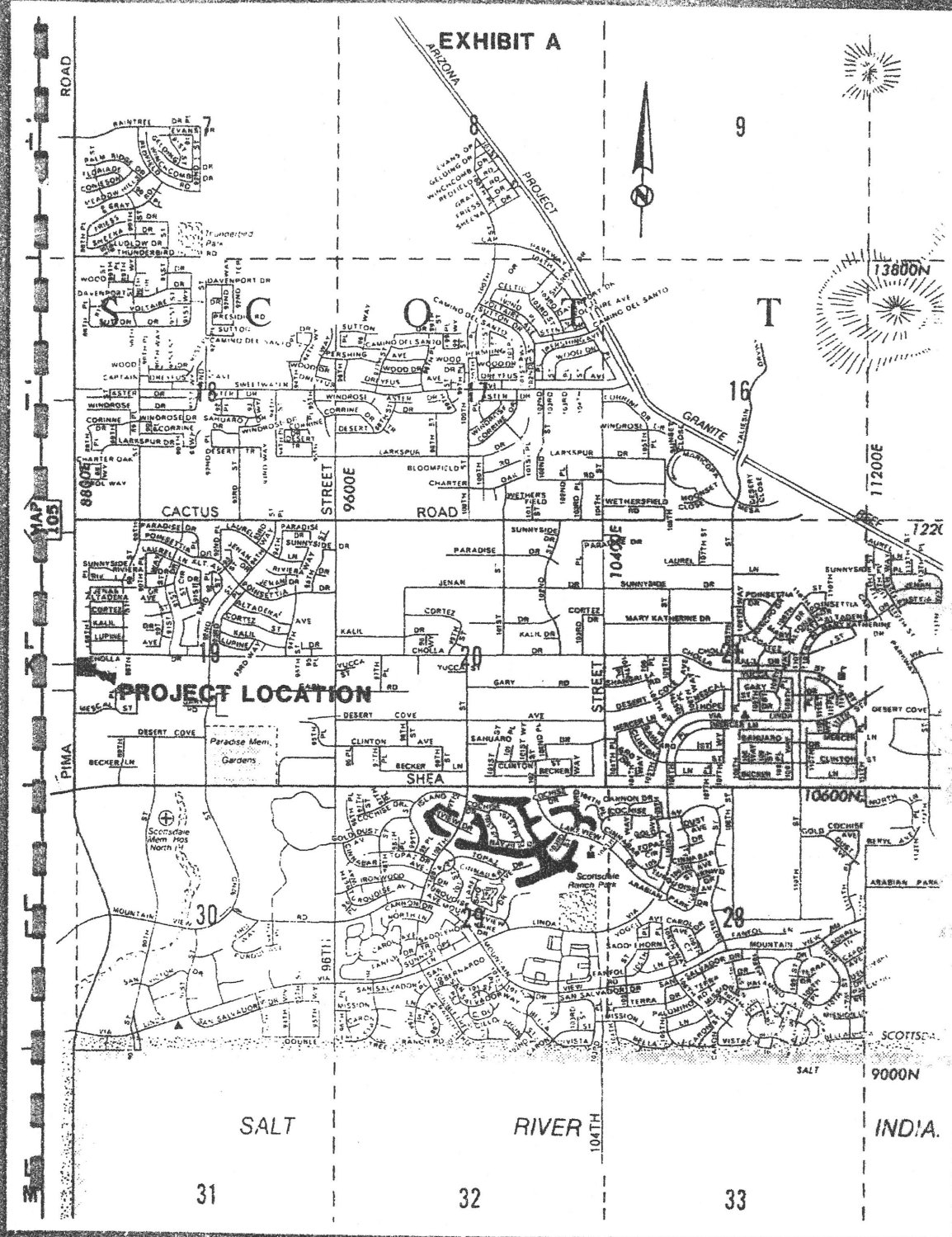

EXHIBIT B

PARADISE VALLEY QUADRANGLE

ARIZONA—MARICOPA CO.

7.5 MINUTE SERIES (TOPOGRAPHIC)

3651 IN NE  
(MC DOWELL  
PEAK)

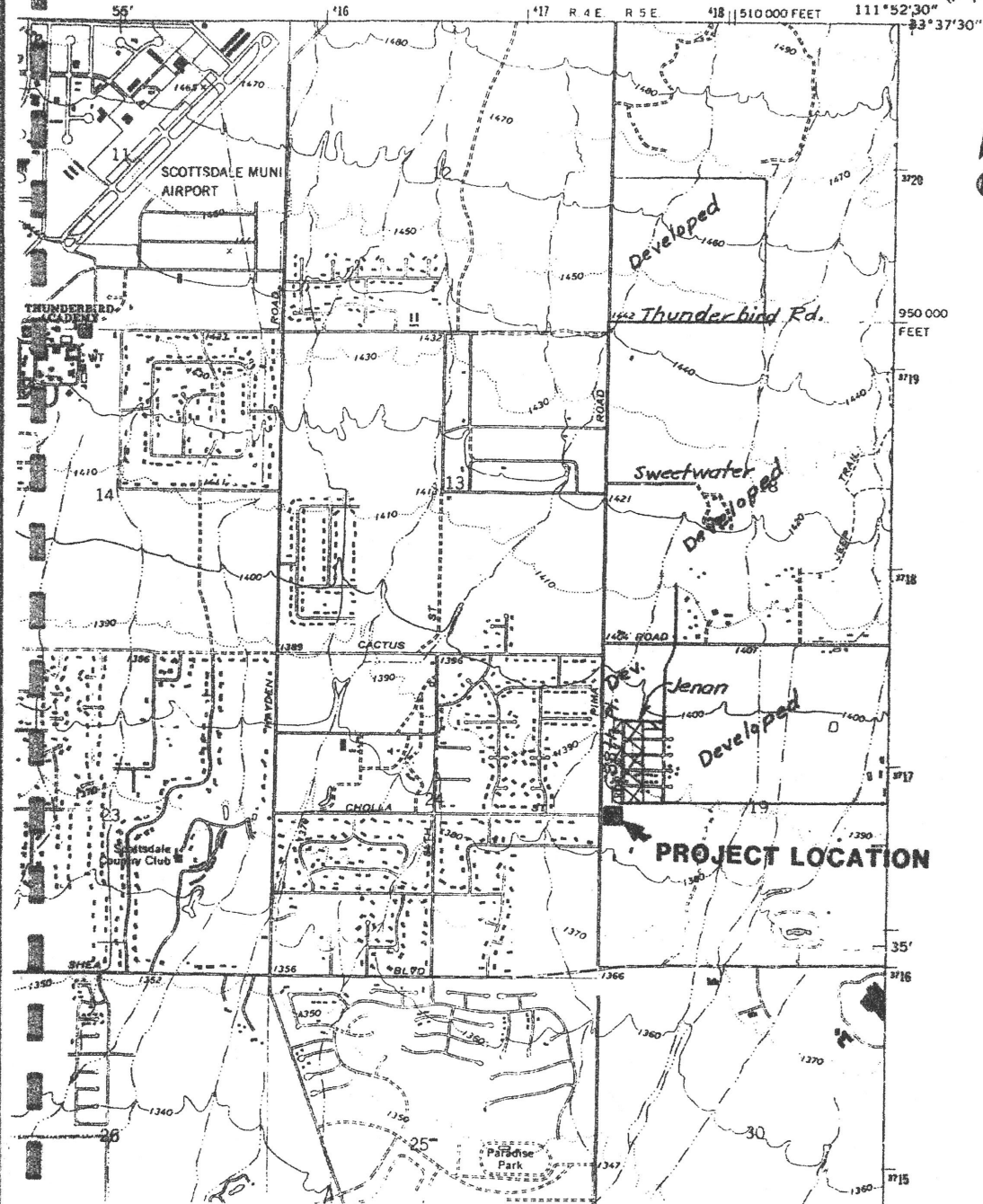

001503

001504

EXHIBIT C

ARIZONA HIGHWAY DEPARTMENT  
BRIDGE DIVISION

HYDROLOGIC DESIGN DATA SHEET  
RATIONAL METHOD

LOCATION DATA

Highway Pima Road County Maricopa  
Location N.E. corner Pima Road & Cholla Drive  
Project No. \_\_\_\_\_ Station \_\_\_\_\_  
Name of Stream Street Runoff - Ricco Villas #2 Subdivision

DESIGN DATA

Design Frequency 100 10 years  
Drainage Area A<sub>1</sub> 26 acres  
A<sub>2</sub> acres  
Drainage Length 2,100 feet  
Elevation  
Top of Drainage Area \_\_\_\_\_ feet  
At Structure \_\_\_\_\_ feet  
Drainage Area Slope 0.76 %  
Precipitation  
P = 6-hour \_\_\_\_\_ inches  
P = 24-hour \_\_\_\_\_ inches

DESIGN COMPUTATIONS

Precipitation  $P_1 = 1$ -hour 2.41 1.61 inches  
Time of Concentration  $T_c$  18 minutes  
Rainfall Intensity  $i$  5.0 3.4 inches/hour  
Curve Numbers  
 $CN_1$  \_\_\_\_\_  
 $CN_2$  \_\_\_\_\_  
Weighted Curve Number  $CN_w$  89 89  
Runoff Coefficient  $C$  0.57 0.44  
Peak Discharge  $Q_p = CiA =$  74 39 cfs

Computed by P. E. Truders Date 10-25-89

**SPEEDIE AND ASSOCIATES**  
 GEOTECHNICAL AND SITE ENGINEERS  
 1029 N. 24th AVE., SUITE 605 • PHOENIX, ARIZONA 85029  
 140 W. IRON AVE., SUITE 108 • MESA, ARIZONA 85202

**EXHIBIT D**

JOB ARMENIAN APOSTOLIC CHURCH  
 PROJECT NO. 880199CA  
 CALCULATED BY P.E.T. DATE 10-25-89  
 CHECKED BY G.E.S. DATE \_\_\_\_\_  
 SHEET NO. \_\_\_\_\_ OF \_\_\_\_\_

**DRAINAGE DITCH CAPACITY**

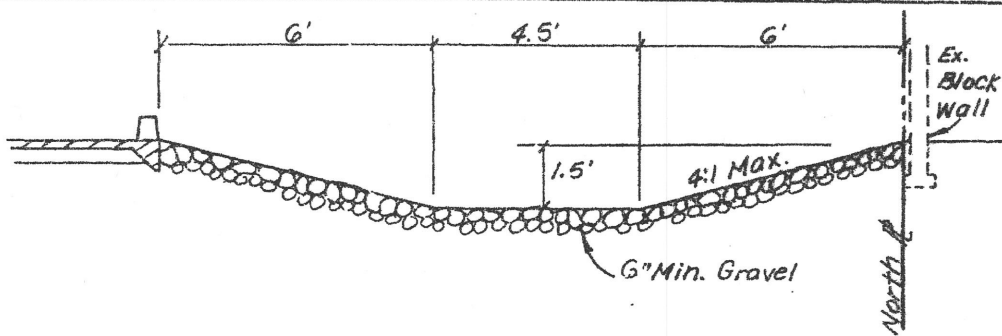

$$Q = \frac{1.49}{n} A R^{2/3} S_o^{1/2} = \text{cfs}$$

$$n = 0.025 \text{ (gravel)}$$

$$A = (6 \times 1.5) + (4.5 \times 1.5) = 15.75 \text{ s.f.}$$

$$R = \frac{A}{P} = \frac{15.75}{16.87} = 0.934$$

$$S_o^{1/2} = \frac{2}{250} = 0.008 \text{ ft./ft.}$$

$$Q = \frac{1.49}{0.025} (15.75) (0.934)^{2/3} (0.008)^{1/2}$$

$$Q = 80.22 \text{ cfs}$$

10.35-A

001506

001506

001507

**L SPEEDIE AND ASSOCIATES**  
 GEOTECHNICAL AND SITE ENGINEERS  
 1079 N 24th AVE., SUITE 805 • PHOENIX, ARIZONA 85029  
 40 W IRON AVE., SUITE 108 • MESA, ARIZONA 85202

**EXHIBIT E**

JOB ARMENIAN APOSTOLIC CHURCH

PROJECT NO. 880199CA

CALCULATED BY P.E.T. DATE 10-25-89

CHECKED BY G.E.S. DATE \_\_\_\_\_

SHEET NO. \_\_\_\_\_ OF \_\_\_\_\_

Detention Basin Calculations: 10' year, 2-hour storm

$$V = \frac{DXA}{12} C_w \quad D = 2.82$$

Area: (excluding drainage ditch along north side and drainage easement east side of Pima Road.)

Total Area = 3 Ac = 130,680 s.f.  
 $A = 130,680 - (17,480 + 3,927) = 109,273 \text{ s.f.}$

C<sub>w</sub>:

Buildings:	$\frac{A}{19,675} \text{ s.f.}$	$\frac{C}{0.95}$	18,691
Concrete:	$\frac{7,884}{} \text{ s.f.}$	$\frac{0.90}{} =$	7,096
Asphalt:	$\frac{31,980}{} \text{ s.f.}$	$\frac{0.85}{} =$	27,183
Landscape:	$\frac{49,734}{} \text{ s.f.}$	$\frac{0.45}{} =$	22,380
	<u>109,273 s.f.</u>		<u>75,350</u>

$$C_w = \frac{75,350}{109,273} = 0.69$$

Volume Required:

$$V_r = \frac{2.82 \times 109,273}{12} \times 0.69$$

$$V_r = 17,719 \text{ cu. ft.}$$

Volume Provided:

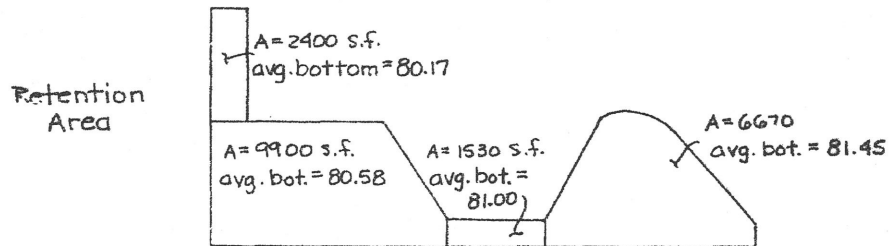

Total A = 20,500 s.f. H.W. = 81.80

$$V_p = (0.35 \times 6670) + (0.8 \times 1530) + (1.22 \times 9900) + (1.63 \times 2400)$$

$$V_p = 19,549 \text{ cu. ft.}$$

10.35-A

# SPEEDIE AND ASSOCIATES

GEOTECHNICAL AND SITE ENGINEERS

11029 N. 24th AVE., SUITE 805 • PHOENIX, ARIZONA 85029 • (602) 997-8391

JAMES A. SPEEDIE, P.E.  
GREGG A. CREASER, P.E.  
GARY E. STOCKER, P.E.  
STEVEN A. GRIESS, P.E.

## REPORT ON SOIL INVESTIGATION

DESIGNATION: Armenian Apostolic Church  
LOCATION: Pima Road & Cholla Road  
Scottsdale, Arizona  
CLIENT: Armenian Apostolic Church  
of Maricopa County  
PROJECT NO: 880199SA  
DATE: August 15, 1988

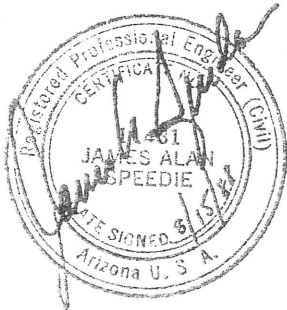
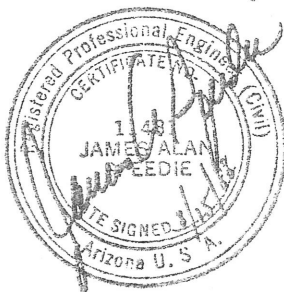

TABLE OF CONTENT

	<u>PAGE</u>
INTRODUCTION . . . . .	1
GENERAL SITE AND SOIL CONDITIONS . . . . .	1
Site Conditions . . . . .	1
Soil Conditions . . . . .	1
ANALYSIS AND RECOMMENDATIONS . . . . .	2
Analysis . . . . .	2
Site Preparation . . . . .	2
Foundation Design . . . . .	3
Lateral Pressures . . . . .	4
Fill And Backfill . . . . .	4
Utilities Installation . . . . .	5
Slabs-On-Grade . . . . .	6
Asphalt Pavement . . . . .	6
GENERAL . . . . .	6
APPENDIX	



## INTRODUCTION

This report presents the results of a subsoil investigation carried out at the site of the proposed Armenian Apostolic Church. The site is located on the southeast corner of Cholla and Pima Roads in Scottsdale, Arizona.

Preliminary information calls for the construction of a one or two-story sanctuary, cultural center and gavit (covered outdoor meeting area) to be located generally as shown on the Soil Boring Location Plan, Plate 1. The structures will be slab-on-grade with masonry or wood-frame bearing walls. Structural loads will be light to moderate and no special considerations regarding settlement tolerance are known. Adjacent areas will be landscaped or paved to support moderate passenger and light commercial traffic. Landscaped areas will be utilized for storm water retention and disposal.

## GENERAL SITE AND SOIL CONDITIONS

Site Conditions - The rectangularly shaped site is approximately 3.0 acres in size and is bounded on the west by Pima Road, on the north by Cholla Road, and on the south and east by undeveloped desert. At the time of the investigation the site was covered with moderately thick desert vegetation. Several ephemeral drainage channels intersect the site in a generally northeast to southwest direction. Several moderately graded dirt roads pass through the site. There was no evidence of any previous structural fills or foundations.

Soil Conditions - Subsoil conditions at the site are relatively uniform throughout. The upper 3.0 to 8.0 feet consists of firm to very stiff, brown to red-brown silt, sandy silt and clayey silt. Variable trace gravel and cementation is also present in this stratum. Moisture contents range from 3 to 5 percent and plastic limits range from non-plastic to 17 percent. In-place dry densities are on the order of 93 to 102 PCF. These soils exhibit a Standard Penetration Resistance (SPT) of 7 to 18 blows per foot. Swell tests indicate that the surface soils have a low potential for volume increase due to wetting when compacted to moistures and densities expected during construction.

The upper 3.0 to 8.0 feet is underlain by medium dense to very dense, brown to red-brown clayey sand and gravelly sand and hard, brown to red-brown sandy clay. Moisture contents are on the order of 3 percent and in-place densities are on the order of 108 PCF. This stratum exhibits a Standard Penetration Resistance of 15 to 50-plus blows per foot.

All borings were dry upon completion and groundwater is not reported to be shallow in this area. Therefore, groundwater should not be a factor in the design or construction of shallow foundations.

#### ANALYSIS AND RECOMMENDATIONS

Analysis - Analysis of the field and laboratory data indicates that subsoils at the site are favorable for the support of the proposed structures, provided that the upper foundation soils are stabilized by overexcavation and recompaction.

Site Preparation - The entire area to be occupied by the proposed construction should be stripped of all vegetation, debris, rubble and obviously loose surface soils. In addition, the native soils should be overexcavated to a depth of 18 inches below proposed footing elevation and extending at least 2.0 feet beyond the footing edges. The native soils may be saved for replacement in these excavations.

Prior to placing structural fill below footing bottom elevation, the exposed subgrade should be scarified to a depth of 8 inches, moisture conditioned to optimum (+2 percent) and compacted to at least 95 percent of maximum dry density as determined by ASTM D-698. Pavement areas should be treated in a similar manner.

All cut areas and areas above footing bottom elevation that are to receive floor slab fill should be scarified 8 inches, moisture conditioned to optimum (+2 percent) and uniformly compacted to 95 percent of maximum dry density.

Foundation Design - It is recommended that the structure be founded on shallow spread footings bearing on properly compacted fill at a minimum depth of 18 inches below finished exterior grade. If site preparation is carried out as set forth herein, a recommended safe allowable bearing capacity of 2,500 psf can be utilized for design. This bearing capacity refers to the total of all loads, dead and live, and is a net pressure. It may be increased one-third for wind, seismic or other loads of short duration. All footing excavations should be level and cleaned of all loose or disturbed materials. Positive drainage away from the proposed buildings must be maintained at all times.

Continuous wall footings and isolated rectangular footings should be designed with minimum widths of 16 and 24 inches respectively, regardless of the resultant bearing pressure. Lightly loaded interior partitions (less than 800 plf) may be supported on reinforced thickened slab sections (minimum 12 inches of bearing width).

Estimated settlements under design loads are on the order of 1/2-inch, virtually all of which will occur during construction. Post-construction differential settlements will be negligible, under existing and compacted moisture contents. Additional localized settlements of the same magnitude could occur if native supporting soils were to experience a significant increase in moisture content. Positive drainage away from structures, and controlled routing of roof runoff should be provided to prevent ponding adjacent to perimeter walls. Planters requiring heavy watering should be considered in this regard. Care should be taken in design and construction to insure that domestic and interior storm drain water is contained to prevent seepage.

Continuous footings and stem walls should be reinforced to distribute stresses arising from small differential movements, and long walls should be provided with control joints to accommodate these movements. Reinforcement and control joints are suggested to allow slight movement and prevent minor floor slab cracking.

Lateral Pressures - The following lateral pressure values may be utilized for the proposed construction:

Active Pressure

Unrestrained Walls	35 PCF
Restrained Walls	60 PCF

Passive Pressure

Continuous Footings	350 PCF
Spread Footings	400 PCF

Coefficient of Friction

With Passive Pressure	0.35
Without Passive Pressure	0.45

All backfill must be compacted to not less than 95 percent (ASTM D-698) to mobilize these passive values at low strain.

Fill and Backfill - Native soils are suitable for use in grading fills. If imported common fill for use in site grading is required, it should be examined by a Soils Engineer to ensure that it is of low swell potential and free of organic or otherwise deleterious material. In general, the fill should have 100 percent passing the 3-inch sieve and no more than 60 percent passing the 200 sieve. For the fine fraction (passing the 40 sieve), the liquid limit and plasticity index should not exceed 30 percent and 10 percent, respectively. It should exhibit less than 1.5 percent swell potential when compacted to 95 percent of maximum dry density (ASTM D-698) at a moisture content of 2 percent below optimum, confined under a 100 psf surcharge, and inundated.

Fill should be placed on subgrade which has been properly prepared and approved by a Soils Engineer. Fill must be wetted and thoroughly mixed to achieve optimum moisture content,  $\pm 2$  percent (optimum to  $+3$  percent for underslab fill). Fill should be placed in horizontal lifts of 8-inch thickness (or as dictated by compaction equipment) and compacted to the percent of maximum dry density per ASTM D-698 set forth as follows:

A.	Building Areas	
1.	Below footing level	95
2.	Below slabs-on-grade (non-expansive soils)	95
B.	Pavement Subgrade or Fill	95
C.	Utility Trench Backfill	
1.	More than 1.5' below finish S/G	90
2.	Within 1.5' of finish S/G	95
D.	Aggregate Base Course	
1.	Below floor slabs	95
2.	Below asphalt paving	100
E.	Landscape Areas	
1.	Miscellaneous fill	90
2.	Utility trench - more than 1.0' below F/G	85
3.	Utility trench - within 1.0' of F/G	90

Utilities Installation - Trench excavations for utilities can be accomplished by conventional trenching equipment. Trench walls will stand near-vertically for the short periods of time required to install utilities. If trenches are greater than shoulder-height, precautions must be taken to protect workmen.

Backfill of trenches may be carried out with native excavated material. This material should be moisture-conditioned, placed in 8 inch lifts and mechanically compacted. Water settling is not recommended. Compaction requirements are summarized in the "Fill And Backfill" section of this report.

Although backfilling in compacted lifts is preferred to minimize pavement settlements, it is seldom achieved by local contractors. A less desirable, but more expedient process would involve backfill of trenches to 18 inches below finish subgrade, jetting as set forth in Section 601 of the M.A.G. Specification, and allowing time for moisture stabilization. The surface should then be thoroughly wheel-rolled to provide stable conditions. The upper 18 inches should then be placed in two moisture-conditioned lifts and compacted to not less than 95 percent of maximum dry density.

Slabs-On-Grade - To facilitate fine grading operations and aid in concrete curing, a 4-inch thick layer of granular material conforming to the gradation for Aggregate Base Course (A.B.C.) as per M.A.G. Specification Section 702 should be utilized beneath the slab. Dried subgrade soils should be moistened prior to placing the A.B.C.

Asphalt Pavement - If earthwork in paved areas is carried out to finish subgrade elevation as set forth herein, the subgrade will provide adequate support for pavements.

For pavement areas to be used primarily for passenger traffic and parking, our experience in the area indicates that a minimum of 2.0 inches of asphalt over 4.0 inches of aggregate base course will provide satisfactory service; heavy duty areas should be 2.5 inches of asphalt over 6.0 inches of base. This assumes that all subgrades are prepared in accordance with the recommendations contained in the "Site Preparation" and "Fill and Backfill" sections of this report, and paving operations carried out in a proper manner. If pavement subgrade preparation is not carried out immediately prior to paving, the entire area should be proof-rolled at that time with a heavy pneumatic-tired roller to identify locally unstable areas for repair.

Pavement base course material should be A.B.C. per M.A.G. Section 702 Specifications. Asphalt concrete materials and mix design should conform to M.A.G. 710. It is recommended that mix designation C-3/4 be used for the pavements. While this mix has a somewhat rougher texture, it offers more stability. Pavement installation should be carried out under applicable portions of M.A.G. Section 321.

#### GENERAL

The scope of this investigation and report does not include regional considerations such as seismic activity and ground fissures resulting from subsidence due to groundwater withdrawal, nor any considerations of hazardous releases or toxic contamination of any type.

Our analysis of data and the recommendations presented herein are based on the assumption that soil conditions do not vary significantly from those found at specific sample locations. Our work has been

performed in accordance with generally accepted engineering principles and practice; this warranty is in lieu of all other warranties expressed or implied.

We recommend that a Soils Engineer monitor the earthwork and foundation portions of this project to ensure compliance to project specifications and the field applicability of subsurface conditions which are the basis of the recommendations presented in this report. If any significant changes are made in the scope of work or type of construction that was assumed in this report, we must review such revised conditions to confirm our findings if the conclusions and recommendations presented herein are to apply.

Respectfully submitted,



Stephen J. Smelser, Geologist

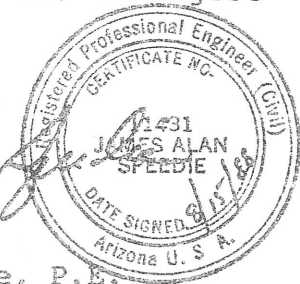

James A. Speedie, P.E.

August 15, 1988

APPENDIX

FIELD AND LABORATORY INVESTIGATION . . . . . Page 1 of 1

SOIL BORING LOCATION PLAN . . . . . Plate 1

SOIL LOG LEGEND . . . . . Plate 2

LOG OF TEST BORING: Boring No. B-1 . . . . . Figure No. 1  
                          Boring No. B-2 . . . . . Figure No. 2  
                          Boring No. B-3 . . . . . Figure No. 3  
                          Boring No. B-4 . . . . . Figure No. 4  
                          Boring No. B-5 . . . . . Figure No. 5

TABULATION OF TEST DATA . . . . . Figure No. 6

CONSOLIDATION DATA . . . . . Figure No. 7

SWELL TEST DATA . . . . . Figure No. 8

FIELD AND LABORATORY INVESTIGATION

On July 21, 1988, five soil test borings were drilled at the approximate locations shown on the attached Soil Boring Location Plan, Plate 1. All exploration work was carried out under the full-time supervision of our engineer, who recorded subsurface conditions and obtained samples for laboratory testing. The soil borings were advanced with a truck-mounted Mobile B-61 drill rig utilizing 7.0 inch diameter hollow stem flight augers. Detailed information regarding the borings and samples obtained can be found on an individual Log of Test Boring prepared for each drilling location.

Laboratory testing consisted of moisture content, dry density, grain-size distribution and plasticity (Atterberg Limits) tests for classification and pavement design parameters. Compression tests were performed on a selected ring sample in order to estimate settlements and determine effects of inundation. Remolded swell tests were performed on samples compacted to densities and moisture contents expected during construction. All field and laboratory data is presented in this Appendix as Figures No. 1 through 8.



# SOILS CLASSIFICATION CHART

MAJOR DIVISIONS		GRAPH SYMBOL	LETTER SYMBOL	TYPICAL DESCRIPTIONS
COARSE GRAINED SOILS	GRAVEL AND GRAVELLY SOILS		GW	WELL-GRADED GRAVEL, SAND, LITTLE OR NO FINES
			GP	POORLY-GRADED GRAVEL, SAND, LITTLE OR NO FINES
	MORE THAN 50% OF COARSE FRACTION RETAINED ON NO. 20 SIEVE		GM	SILT GRAVEL, SAND-SILT MIXTURES
			GC	CLAYEY GRAVEL, GRAVEL-SAND CLAY MIXTURES
MORE THAN 50% OF MATERIAL IS LARGER THAN NO. 100 SIEVE SIZE	CLEAR SAND (LITTLE OR NO FINES)		SW	WELL-GRADED SAND, LITTLE OR NO FINES
			SP	POORLY-GRADED SAND, LITTLE OR NO FINES
	SANDS WITH FINES (APPRECIABLE AMOUNT OF FINES)		SM	SILT SAND, SAND-SILT MIXTURES
			SC	CLAYEY SAND, SAND-CLAY MIXTURES
FINE GRAINED SOILS	SILTS AND CLAYS		ML	INORGANIC SILTS AND VERY FINE SAND, LOW PLASTICITY
			CL	INORGANIC CLAYS OF LOW TO MEDIUM PLASTICITY, SANDS, SILTS AND CLAYS WITH SLIGHT PLASTICITY
	MORE THAN 50% OF MATERIAL IS FINER THAN NO. 200 SIEVE SIZE	LIQUID LIMIT GREATER THAN 50	OL	INORGANIC SILTS AND ORGANIC SILTY CLAYS OF LOW PLASTICITY
			OH	ORGANIC SILTS, MARGINAL OR MEDIUM PLASTICITY
LIQUID LIMIT LESS THAN 50	LIQUID LIMIT GREATER THAN 50	CH	INORGANIC CLAYS OF HIGH PLASTICITY, FAT CLAYS	
		OH	ORGANIC CLAYS OF HIGH PLASTICITY, ORGANIC SILTS	
HIGHLY ORGANIC SOILS			PT	PEAT, MUCK, SILT, MUD, ETC. WITH HIGH ORGANIC CONTENTS

## GRADATION CHART

MATERIAL SIZE	PARTICLE SIZE				
	LOWER LIMIT		UPPER LIMIT		
	MILLIMETERS	NO. 10 SIEVE	MILLIMETERS	NO. 10 SIEVE	
SAND	FINE	0.075	600µ	0.425	425µ
	COARSE	0.075	600µ	0.425	425µ
GRAVEL	FINE	0.075	600µ	100	100µ
	COARSE	0.075	600µ	100	100µ
COBBLES	FINE	75	3"*	300.0	12"
	COARSE	300.0	12"	300.0	12"

\*U.S. Standard    \*Other Square Openings

## PLASTICITY CHART

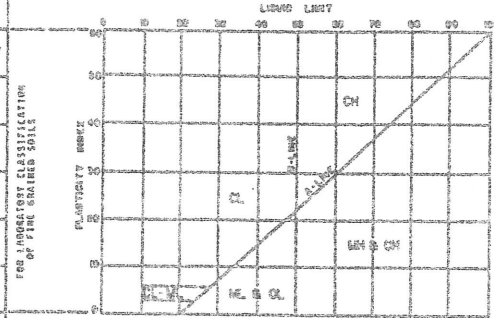

CONSISTENCY			RELATIVE DENSITY	
CLAYS & SILTS	BLOWS/FOOT*	STRENGTH †	SANDS & GRAVELS	BLOWS/FOOT*
VERY SOFT	0-2	0-1	VERY LOOSE	0-4
SOFT	2-4	1-2	LOOSE	4-10
MEDIUM SOFT	4-10	2-5	MEDIUM DENSE	10-30
FIRM	10-30	5-15	DENSE	30-50
STIFF	30-50	15-30	VERY DENSE	50-100

\* Number of blows of 140 pound hammer falling 30 inches to drive a 1 inch S.B. (1-3/8 inch I.D.) split spoon (ASTM D-1586).  
 † Unconfined compressive strength in tons/sq. ft. Read from a pocket penetrometer.

SAMPLE DESIGNATION	PENETRATION RESISTANCE SYMBOL	DESCRIPTION
Bag	-	Large Bulk Sample
BS	-	Misc. Grab Sample - Bottle or Bag
AS	-	Auger Sample - A grab sample taken directly from auger flights
S	⊙	Spoon Sample - Standard Penetration Test (ASTM D-1586)-Driving a 2.0-inch outside diameter, 1 3/8-inch inside diameter split spoon sampler into undisturbed soil for three successive 6-inch increments of penetration by means of a 140-pound weight falling freely through a distance of 30 inches. The cumulative number of blows required for the final 12 inches of penetration is the Standard Penetration Resistance (N).
LS	⊙	Liner Sample - Standard Penetration Test-Driving a 2.0-inch outside diameter split spoon, equipped with two, 3-inch long by 1 3/8-inch inside diameter brass liners, separated by a 1-inch long spacer, into undisturbed soil as above.
RS	⊙	Ring Sample - Driving a 3.0-inch outside diameter spoon, equipped with a series of 2.42-inch inside diameter, 1-inch long brass rings, into undisturbed soil for one 12-inch increment by means of a 140-pound weight falling freely through a distance of 30 inches. The blows required for the 12 inches of penetration are recorded.
ST	-	Shelby Tube - A 3.0-inch outside diameter thin-walled tube continuously pushed into undisturbed soil by a rapid motion, without impact or twisting. (ASTM D-1587)
-	⊙	Continuous Penetration Resistance (Cone) - Driving a 2.0-inch outside diameter "Cone penetrometer" continuously into undisturbed soil by means of a 140-pound weight falling freely through a distance of 30 inches. The blows for each successive 12-inch increment are recorded.

NOTE: The stratification lines shown on the logs of test borings and/or Test Pit represent the approximate boundary between soil types, and the transition may be gradual.

SOIL LOG  
LEGEND

SPEEDIE & ASSOCIATES  
REGISTERED PROFESSIONAL ENGINEERS  
1429 W. 10th St. S. Oklahoma City, Oklahoma 73106

25-ZN-2018  
25-010-2018-23  
12/15/2020

ELEVATION (FEET)

GROUND SURFACE ELEVATION: <u>N/A</u>		* ELEVATION OF SAMPLE TIP				NATURAL WATER CONTENT (%)		IN-PLACE DRY DENSITY (P.C.F.)		STANDARD PENETRATION NUMBER (N) BLOWS PER FOOT	
SOIL DESCRIPTION		SAMPLE NUMBER	ELEVATION OF SAMPLE TIP	NATURAL WATER CONTENT (%)	IN-PLACE DRY DENSITY (P.C.F.)	STANDARD PENETRATION NUMBER (N) BLOWS PER FOOT					
Stiff Brown SANDY SILT (ML - Dry) With A Trace Of Gravel.  3.0'		RS-1	2.0	4.3	93.9						
Medium Dense Brown SAND (SM - Dry) With A Trace Of Silt And Gravel.  8.5'		S-2	5.5	4.6	-						
Dense Brown CLAYEY SAND (SC - Dry) With A Trace Of Gravel, Air Voids And Weak Cementation.  12.5'		S-3	10.5	-	-						
Dense Light Brown And White Mottled SAND (SP - Dry) With A Trace Of Clay And Gravel And Weak Cementation.  18.5'		S-4	15.5	-	-						
Very Dense Light Brown CLAYEY SAND (SC - Dry) With A Trace Of Gravel And Strong Cementation.  19.8'		S-5	19.8	-	-	95/10"					

END OF BORING  
\* Sample Depth

BORING STARTED: 07-21-88  
 BORING COMPLETED: 07-21-88  
 FIELD ENGINEER/TECHNICIAN: S. Smelser  
 DRILLER: D. Ulser  
 CONTRACTOR: Heber Mining

WATER LEVEL IN HOLE AT Dry  
 NUMBERS OF HOURS AFTER COMPLETION:

<b>SPEEDIE AND ASSOCIATES</b>	
LOG OF TEST BORING NUMBER <u>B-1</u>	
ARMENIAN APOSTOLIC CHURCH PIMA ROAD & CHOLLA ROAD SCOTTSDALE, ARIZONA	
APPROVED: <u>SSS</u>	DATE: 08-12-88
PROJECT NO <u>880199SA</u>	FIGURE NO:

25-ZN-2018  
 29\_07\_2018  
 12/15/2020

ELEVATION (FEET)

GROUND SURFACE ELEVATION: <u>N/A</u>		*				
SOIL DESCRIPTION		SAMPLE NUMBER	ELEVATION OF SAMPLE TIP	NATURAL WATER CONTENT (%)	IN-PLACE DRY DENSITY (P.C.F.)	STANDARD PENETRATION NUMBER (N) BLOWS PER FOOT
						0      25      50
Stiff Brown SANDY SILT (ML - Dry) With A Trace Of Gravel. <span style="float: right;">3.0'</span>		S-1	2.5	3.7	-	
Medium Dense Red-Brown GRAVELLY SAND (SP - Dry). <span style="float: right;">8.0'</span>		RS-2	5.0	2.8	107.8	
Very Dense Brown And White Mottled CLAYEY SAND (SC - Dry) With A Trace Of Air Voids And Weak Cementation. <span style="float: right;">10.5'</span>		S-3	10.5	-	-	
END OF BORING						

\* Sample Depth

BORING STARTED: 07-21-88  
 BORING COMPLETED: 07-21-88  
 FIELD ENGINEER/TECHNICIAN: S. Smelser  
 DRILLER: D. Ulses  
 CONTRACTOR: Heber Mining

WATER LEVEL IN HOLE AT Dry  
 NUMBERS OF HOURS AFTER COMPLETION:

**SPEEDIE AND ASSOCIATES**

LOG OF TEST BORING NUMBER B-2

ARMENIAN APOSTOLIC CHURCH  
 PIMA ROAD & CHOLLA ROAD  
 SCOTTSDALE, ARIZONA

APPROVED: <u>SJS</u>	DATE: 08-12-88
PROJECT NO: 880199SA	FIGURE NO: 25-ZN-2018

25-ZN-2018  
 07/20/2023  
 12/15/2020

GROUND SURFACE ELEVATION: <u>N/A</u>		*				
SOIL DESCRIPTION		SAMPLE NUMBER	ELEVATION OF SAMPLE TIP	NATURAL WATER CONTENT (%)	IN-PLACE DRY DENSITY (P.C.F.)	STANDARD PENETRATION NUMBER (N) BLOWS PER FOOT
						0      25      50
Stiff Brown SILT (ML - Dry) With A Trace Of Sand And Gravel.  3.0'		RS-1	2.0	4.3	92.9	
Very Stiff Red-Brown SANDY SILT (ML - Dry) With A Trace Of Air Voids And Weak Cementation.  8.0'		S-2	5.5	-	-	
Hard Red-Brown SANDY CLAY (CL - Dry) With Moderate Cementation.  10.5'		S-3	10.5	-	-	
END OF BORING						

ELEVATION (FEET)

\* Sample Depth

BORING STARTED: 07-21-88  
 BORING COMPLETED: 07-21-88  
 FIELD ENGINEER/TECHNICIAN: S. Smelser  
 DRILLER: D. Ulises  
 CONTRACTOR: Heber Mining

WATER LEVEL IN HOLE AT Dry

NUMBERS OF HOURS AFTER COMPLETION:

<b>SPEEDIE AND ASSOCIATES</b>	
LOG OF TEST BORING NUMBER <u>B-3</u>	
ARMENIAN APOSTOLIC CHURCH PIMA ROAD & CHOLLA ROAD SCOTTSDALE, ARIZONA	
APPROVED: <u>SSS</u>	DATE: 08-12-88
PROJECT NO: <u>880199SA</u>	FIGURE NO <u>25-ZN-2018</u>

25-ZN-2018  
 29-07-2018  
 12/15/2020

ELEVATION (FEET)

GROUND SURFACE ELEVATION: <u>N/A</u>		*				
SOIL DESCRIPTION		SAMPLE NUMBER	ELEVATION OF SAMPLE TIP	NATURAL WATER CONTENT (%)	IN-PLACE DRY DENSITY (P.C.F.)	STANDARD PENETRATION NUMBER (N) BLOWS PER FOOT
	Firm Brown SILT (ML - Dry) With A Trace Of Sand And Gravel.	S-1	2.5	-	-	0 25 50
	3.5'	BS-2	3.0	-	-	
	Very Stiff Brown CLAYEY SILT (ML - Dry) With A Trace Of Sand And Gravel.	S-3	5.5	-	-	
	8.0'	S-4	10.5	-	-	
	Dense Light Brown SILTY SAND (SM - Dry).	S-5	15.5	-	-	
	Very Dense Light Brown CLAYEY SAND (SC - Dry) With A Trace Of Gravel And Caliche.	S-6	19.5	-	-	50/6" →
	13.0'					
	Hard Light Brown And White Mottled CLAY (CL - Dry) With A Trace Of Gravel And Air Voids And Moderate Cementation.					
	16.0'					
	END OF BORING					
	19.5'					
	* Sample Depth					

BORING STARTED: 07-21-88  
 BORING COMPLETED: 07-21-88  
 FIELD ENGINEER/TECHNICIAN: S. Smelser  
 DRILLER: D. Ulser  
 CONTRACTOR: Heber Mining

WATER LEVEL IN HOLE AT Dry  
 NUMBERS OF HOURS AFTER COMPLETION:

<b>SPEEDIE AND ASSOCIATES</b>	
LOG OF TEST BORING NUMBER B-4	
ARMENIAN APOSTOLIC CHURCH PIMA ROAD & CHOLLA ROAD SCOTTSDALE, ARIZONA	
APPROVED: SSS	DATE: 08-12-88
PROJECT NO: 880199SA	FIGURE NO:

25-ZN-2018  
 25-DR-07-2018-3  
 12/15/2020

GROUND SURFACE ELEVATION: <u>N/A</u>		*				
SOIL DESCRIPTION		SAMPLE NUMBER	ELEVATION OF SAMPLE TIP	NATURAL WATER CONTENT (%)	IN-PLACE DRY DENSITY (P.C.F.)	STANDARD PENETRATION NUMBER (N) BLOWS PER FOOT
	Firm Light Brown SILT (ML - Dry) With A Trace Of Gravel.	RS-1	2.0	5.1	101.7	0 25 50
	3.5'					
	Very Stiff Red-Brown CLAYEY SILT (ML - Dry) With A Trace Of Sand, Gravel And Air Voids.	S-2	5.5	-	-	
	8.0'					
	Medium Dense Red-Brown GRAVELLY SAND (SP - Dry).	S-3	10.5	-	-	
	13.0'					
	Dense Light Brown GRAVELLY SAND (SP - Dry) With A Trace Of Caliche.	S-4	15.5	-	-	
	15.5'					
	END OF BORING					

ELEVATION (FEET)

\* Sample Depth

BORING STARTED: 07-21-88  
 BORING COMPLETED: 07-21-88  
 FIELD ENGINEER/TECHNICIAN: S. Smelser  
 DRILLER: D. Ulises  
 CONTRACTOR: Heber Mining

WATER LEVEL IN HOLE AT Dry

NUMBERS OF HOURS AFTER COMPLETION:

**SPEEDIE AND ASSOCIATES**

LOG OF TEST BORING NUMBER B-5

ARMENIAN APOSTOLIC CHURCH  
 PIMA ROAD & CHOLLA ROAD  
 SCOTTSDALE, ARIZONA

APPROVED: <u>SSS</u>	DATE: 08-12-88
PROJECT NO: 880199SA	FIGURE NO

# SPEEDIE AND ASSOCIATES

GEOTECHNICAL AND SITE ENGINEERS  
11029 N. 24TH AVE. • SUITE 805 • PHOENIX, ARIZONA • 85028 • (602) 997-0291

## CONSOLIDATION TEST

PROJECT: Armenian Apostolic Church PROJECT NO. 880199SA DATE: 07-27-88  
 LOCATION: Pima Road & Cholla Road - Scottsdale, Arizona  
 CLIENT: Armenian Apostolic Church LAB. SAMPLE NO.: 8656  
 BORING NO.: B-5 FIELD SAMPLE NO.: RS-1 SAMPLE DEPTH: 2.0' SAMPLE ELEV. (TIP): -  
 TESTED BY: JH DATE: 07-22-88 CHECKED BY: SJS DATE: 07-27-88  
 REMARKS: Sample inundated at end of test at 2,000 PSF.

\_\_\_\_\_ In-situ  
 - - - - - Inundated

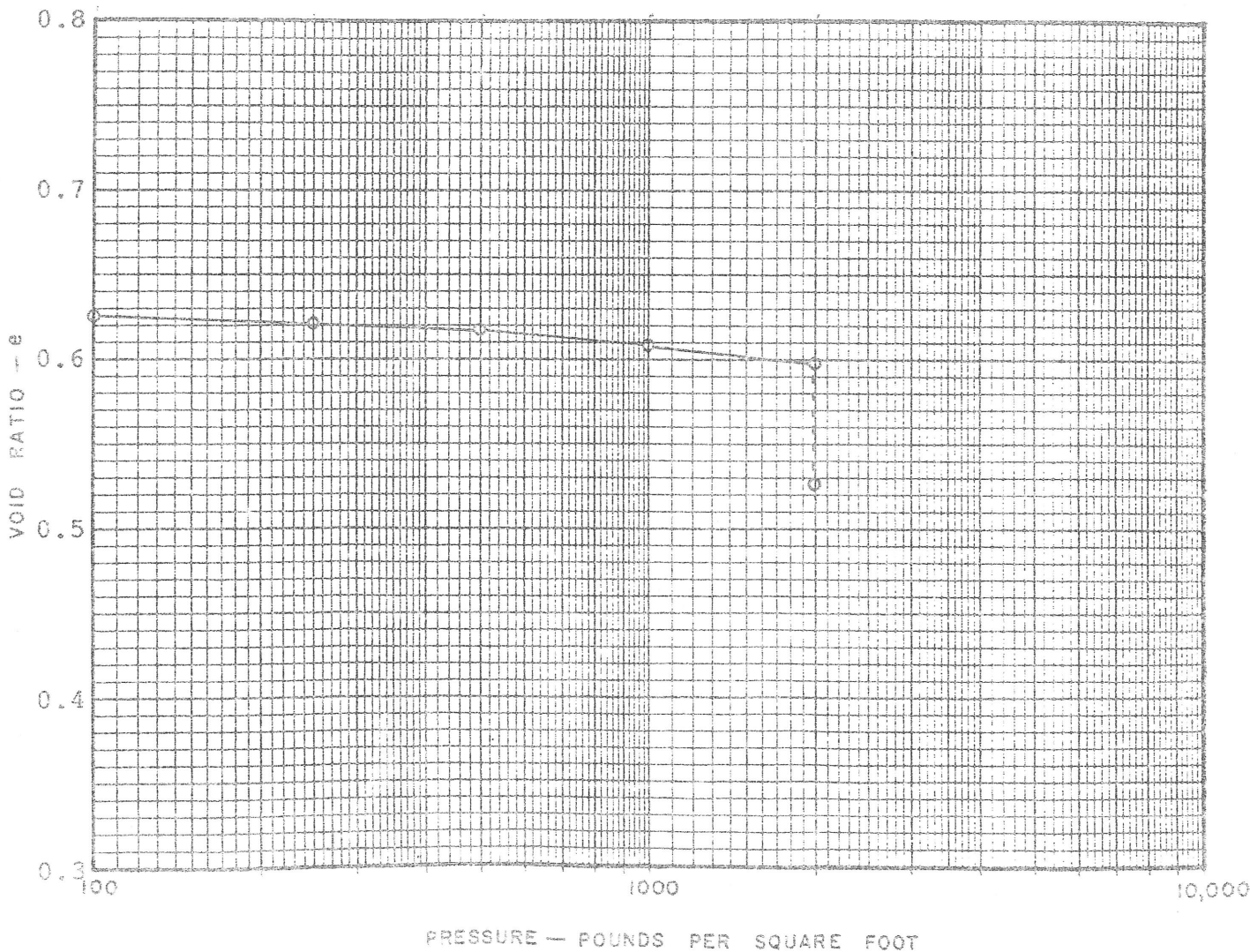

SWELL TEST DATA

BORING/ PIT NO.	SAMPLE DEPTH (FT.)	REMOLED DRY DENSITY (PCF)	INITIAL MOISTURE CONTENT PERCENT	PERCENT * OF COMPACTION	INITIAL DEGREE OF SATURATION PERCENT	FINAL DEGREE OF SATURATION PERCENT	TOTAL SWELL PERCENT
B-4/BS-2	3.0	110.1	15.3	94.3	81.0	92.6	0.3
B-4/BS-2	3.0	109.2	12.2	93.8	62.9	95.4	1.9

\* Based on a maximum dry density of 116.4 PCF at 12.3 percent moisture.

ARMENIAN APOSTOLIC CHURCH  
PIMA ROAD & CHOLLA ROAD  
SCOTTSDALE, ARIZONA

**SPEEDIE**  
**ANP ASSOCIATES**  
GEOTECHNICAL AND SITE ENGINEERS

PROJECT NO. 880199SA

# APPENDIX D

## Weighted 'C' Exhibit

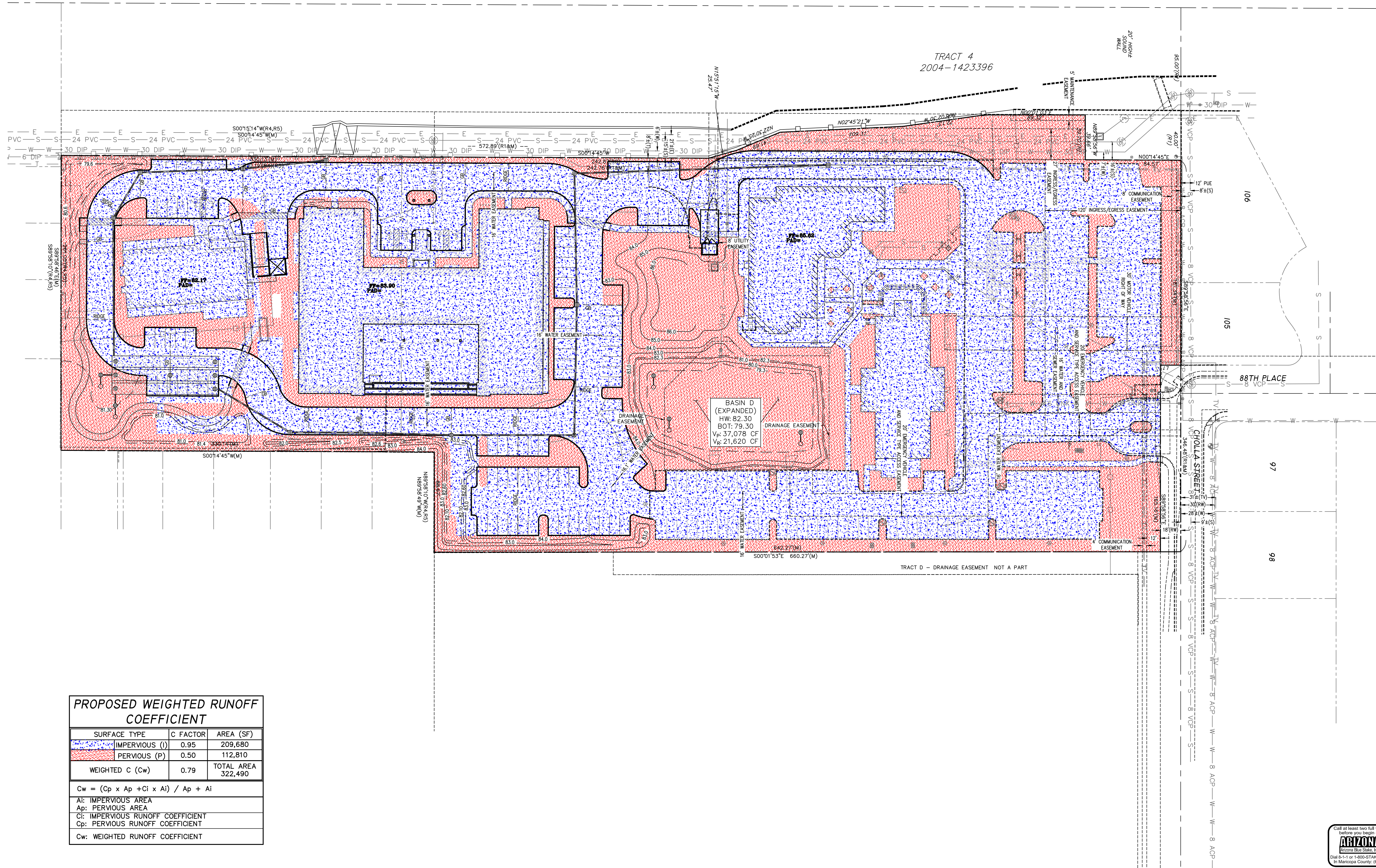
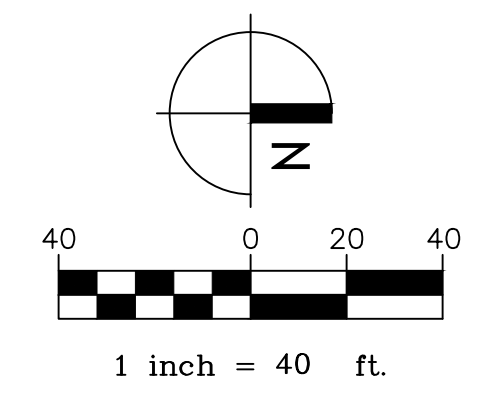

**PROPOSED WEIGHTED RUNOFF COEFFICIENT**

SURFACE TYPE	C FACTOR	AREA (SF)
IMPERVIOUS (I)	0.95	209,680
PERVIOUS (P)	0.50	112,810
<b>WEIGHTED C (Cw)</b>	<b>0.79</b>	<b>TOTAL AREA 322,490</b>

$C_w = (C_p \times A_p + C_i \times A_i) / A_p + A_i$   
 Ai: IMPERVIOUS AREA  
 Ap: PERVIOUS AREA  
 Ci: IMPERVIOUS RUNOFF COEFFICIENT  
 Cp: PERVIOUS RUNOFF COEFFICIENT  
 Cw: WEIGHTED RUNOFF COEFFICIENT

**akai** architecture + interiors  
 480.888.8832  
 7956 E. McDowell Rd., Suite 100, Scottsdale, AZ 85260

**MEGERDICHIAN SENIOR CENTER**  
 8849 E. CHOLLA ST.  
 SCOTTSDALE, AZ 85260

**PRE-CONSTRUCTION PHASE**

NO.	ISSUED FOR:	DATE
1	REZONING & C.U.P.	12-13-2018
2	REZONING & C.U.P. 2nd Review	08-03-2020

**CONSTRUCTION PHASE**

REV.	BULLETIN #	DATE



**KLAND CIVIL ENGINEERS**  
 CIVIL ENGINEERING  
 LAND DEVELOPMENT SERVICES  
 LAND SURVEYING  
 7227 N. 16th St., Suite 217  
 Phoenix, Arizona 85020  
 PHONE: (480) 344-0480  
 www.klandeng.com

**WEIGHTED 'C' EXHIBIT**

DATE: 09/11/2020  
 JOB NUMBER: 1727-00  
 KLAND PROJECT NUMBER: K15153



**WCI OF 1**

**25-ZN-2018**

25-ZN-2018  
 29.09.2020  
 12/15/2020

# APPENDIX E

## Existing Drainage Map

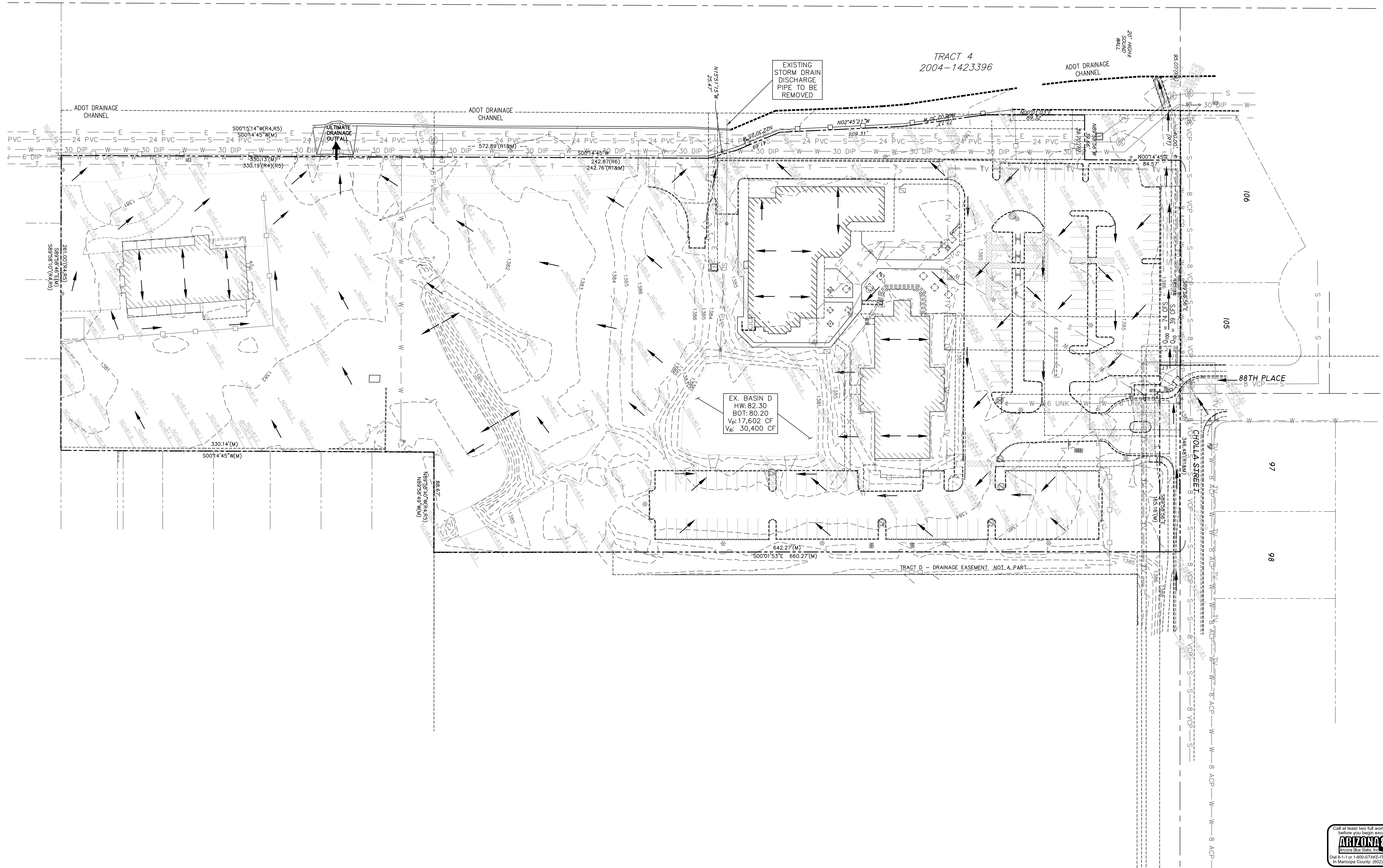
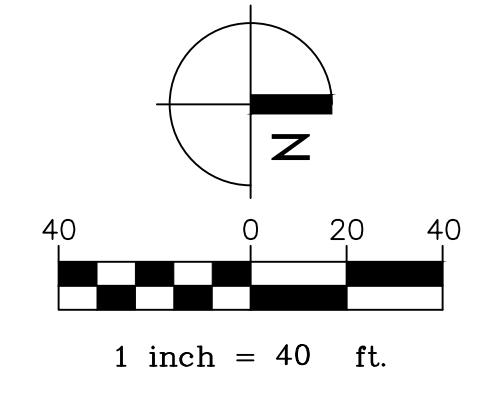

**aakai** architecture + interiors  
7866 a road of fine architecture arizona 85020  
480.888.8822  
aakai.com  
© 2018

**MEGERDICHIAN  
SENIOR CENTER**  
8849 E. CHOLLA ST.  
SCOTTSDALE, AZ 85260

PRE-CONSTRUCTION PHASE		
NO.	ISSUED FOR:	DATE
1	REZONING & C.U.P.	12-13-2018
2	REZONING & C.U.P. 2nd Review	08-03-2020
CONSTRUCTION PHASE		
REV.	BULLETIN #	DATE



**KLAND  
CIVIL ENGINEERS**  
CIVIL ENGINEERING  
LAND DEVELOPMENT  
SERVICES  
LAND SURVEYING  
7227 N. 16th St., Suite 217  
Phoenix, Arizona 85002  
PHONE: (480) 344-0480  
www.klandeng.com

SHEET TITLE  
**EXISTING DRAINAGE  
MAP**

DATE: 09/11/2020  
JOB NUMBER: 1727-00  
KLAND PROJECT NUMBER: K15153



**EX DM  
OF 1**

**25-ZN-2018**

25-ZN-2018  
12/15/2020

# APPENDIX F

## Proposed Drainage Map

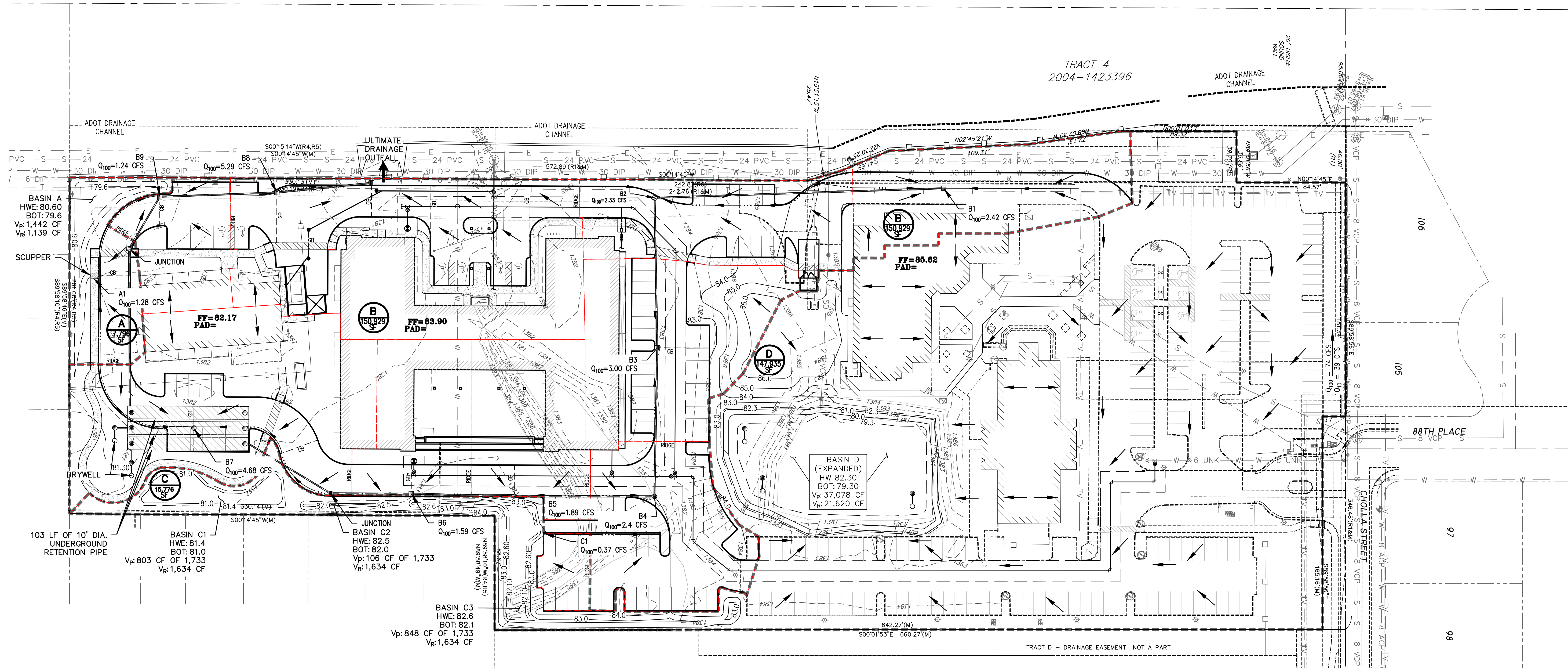
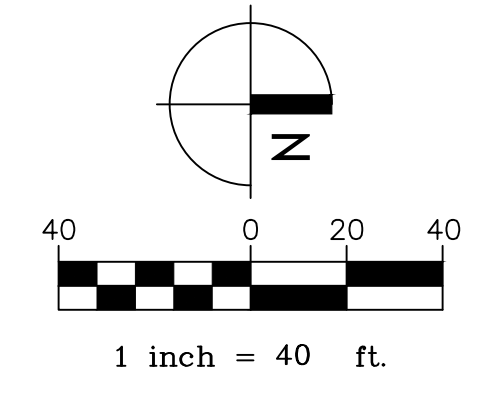

SURFACE BASINS INFORMATION					
BASIN	HWE	BOT	VOL (P)	VOL (R)	TOTAL VOL (P)
A	80.6	79.6	1,442	1,139	1,442
C1	81.4	81.0	803		
C2	82.5	82.0	106	1,634	1,757
C3	82.6	82.1	848		
D	82.3	79.3	37,078	21,620	37,078

RETENTION BASIN CALCULATIONS											
Sub-Area (onsite)	Area (sf)	Area (acre)	C100	P100YR, 2 HR (in)	Vol. Req. (cf)	Surface Vol. Prov. (cf)	Total Tank Length Provided (LF)	Underground Vol. Prov. (cf)	Total Vol. Prov. (cf)	Excess Volume (%)	DRYWELLS
A	7,796.00	0.18	0.79	2.22	1,139.39	1,442.0	0.0	0.0	1,442.0	26.6	0
B	150,929	3.465	0.79	2.22	22,058.3	0.0	282.0	22,148.2	22,148.2	0.4	2
C	15,776	0.362	0.56	2.22	1,634.4	1,757.0	0.0	0.0	1,757.0	7.5	0
D	147,935	3.396	0.79	2.22	21,620.7	37,078.0	0.0	0.0	37,078.0	71.5	3
Total	314,640.0	7.4	-	-	46,452.8	40,277.0	282.0	22,148.2	62,425.2	34.4	5

aakai architecture + interiors

**MEGERDICHIAN SENIOR CENTER**  
8849 E. CHOLLA ST.  
SCOTTSDALE, AZ 85260

PRE-CONSTRUCTION PHASE		
NO.	ISSUED FOR:	DATE
1	REZONING & C.U.P.	12-13-2018
2	REZONING & C.U.P. 2nd Review	08-03-2020

CONSTRUCTION PHASE		
REV.	BULLETIN #	DATE



**KLAND CIVIL ENGINEERS**  
CIVIL ENGINEERING  
LAND DEVELOPMENT  
SERVICES  
LAND SURVEYING  
7227 N. 16th St., Suite 217  
Phoenix, Arizona 85008  
PHONE: (480) 344-0480  
www.klandeng.com

**PROPOSED DRAINAGE MAP**

DATE: 09/11/2020  
JOB NUMBER: 1727-00  
KLAND PROJECT NUMBER: K15153

DMI OF 1



25-ZN-2018

25-ZN-2018  
12/15/2020

# APPENDIX G

## Master Plan

**BENCHMARK**

FOUND BRASS CAP IN HANDHOLE AT THE INTERSECTION OF 92ND STREET AND CHOLLA STREET. CITY OF SCOTTSDALE. GPS POINT 8194. ELEV = 1388.480 (NAVD '88, CITY OF SCOTTSDALE DATUM)

FOUND BRASS CAP IN HANDHOLE AT THE INTERSECTION OF 92ND STREET AND SHEA BOULEVARD. CITY OF SCOTTSDALE. GPS POINT 8301. ELEV = 1372.195 (NAVD '88, CITY OF SCOTTSDALE DATUM)

FOUND BRASS CAP IN HANDHOLE AT THE INTERSECTION OF 84TH STREET AND SHEA BOULEVARD. CITY OF SCOTTSDALE. GPS POINT 3251. ELEV = 1364.811 (NAVD '88, CITY OF SCOTTSDALE DATUM)

**LEGAL DESCRIPTION**

THE LAND REFERRED TO HEREIN BELOW IS SITUATED IN THE COUNTY OF MARICOPA, STATE OF ARIZONA AND IS DESCRIBED AS FOLLOWS: LOT 1, A PROPERTY ASSEMBLAGE IN THE CITY OF SCOTTSDALE, ARIZONA ARMENIAN APOSTOLIC CHURCH OF ARIZONA, ACCORDING TO BOOK 971 OF MAPS, PAGE 46, AND THEREAFTER AFFIDAVIT OF CORRECTION IN RECORDING NO. 2008-0228799, RECORDS OF MARICOPA COUNTY, ARIZONA.

**BASIS OF BEARING**

THE MONUMENT LINE OF 92ND STREET SAID LINE BEARS SOUTH 00 DEGREES 01 MINUTES 20 SECONDS EAST.

**FLOOD ZONE**

ACCORDING TO THE FLOOD INSURANCE RATE MAP #04013C1760L, DATED OCTOBER 18, 2013, THIS PROPERTY IS LOCATED IN FLOOD ZONE "X".

**ARCHITECT**

AAKAI ARCHITECTURE AND INTERIORS  
7585 E. REDFIELD RD., STE 106  
SCOTTSDALE, AZ 85260  
PH: (480) 588-5852  
CONTACT:

**ENGINEER**

KLAND CIVIL ENGINEERS  
7227 N. 16TH ST., STE 217  
PHOENIX, AZ 85020  
PH: (480) 344-0480  
CONTACT: LESLIE KLAND, PE

**MASTER GRADING AND DRAINAGE PLAN**  
**MEGERDICHIAN SENIOR CENTER**

8849 EAST CHOLLA STREET, SCOTTSDALE, ARIZONA 85260  
A PORTION OF LOT 3 IN THE SOUTHWEST QUARTER OF SECTION 19, TOWNSHIP 3 NORTH, RANGE 5 EAST, OF THE GILA AND SALT RIVER BASE AND MERIDIAN, MARICOPA COUNTY, ARIZONA.

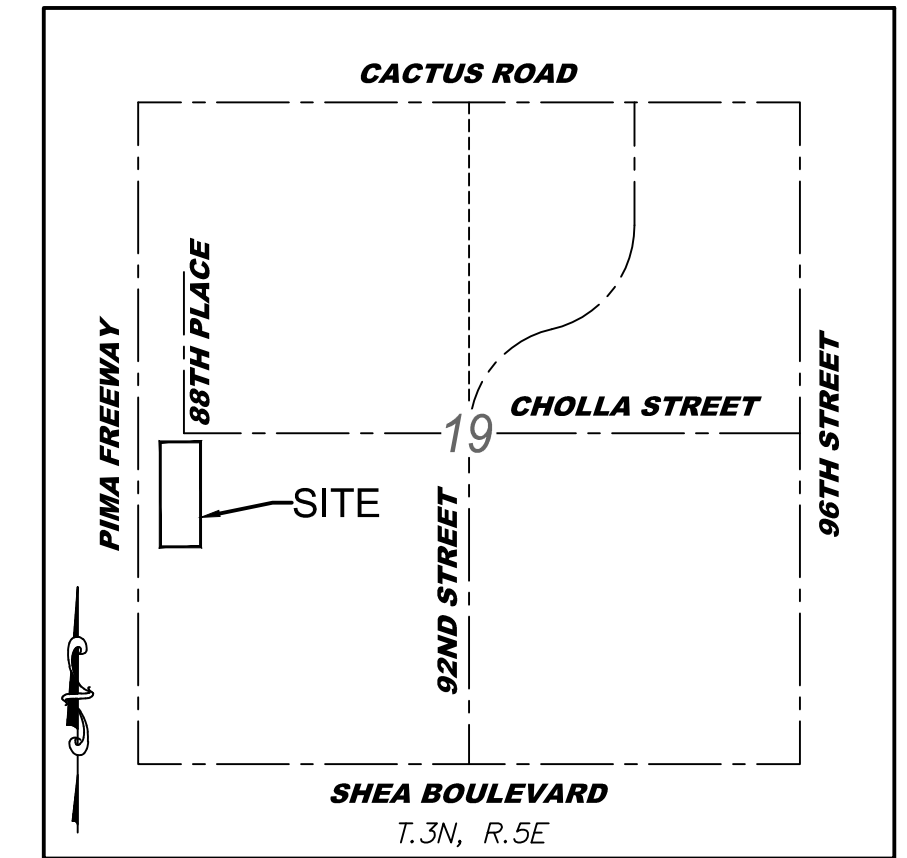

**VICINITY MAP**  
N.T.S.

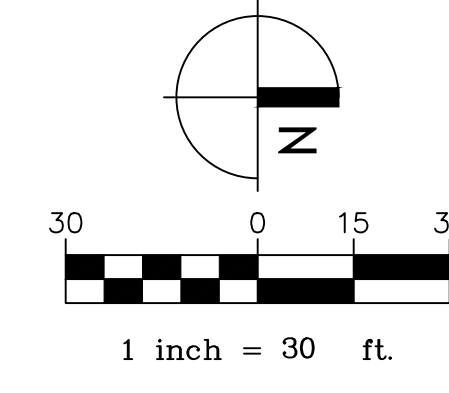
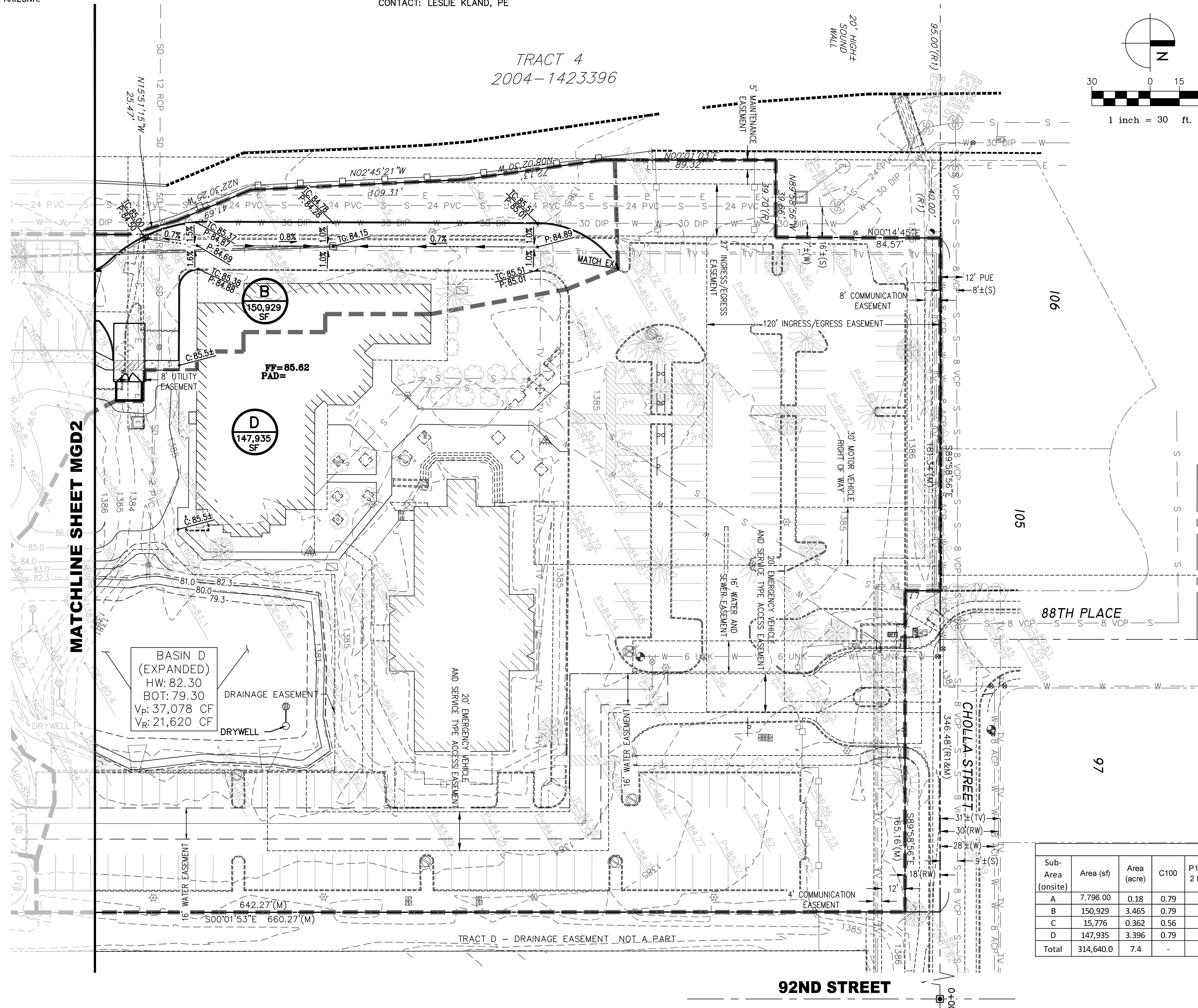

**LEGEND**

EXISTING	DESCRIPTION	PROPOSED
●	SURVEY MARKER	○
---	CURB AND GUTTER	---
---	SIDEWALK	---
---	SINGLE CURB	---
---	NATURAL GROUND	---
---	TOP OF CURB AND GUTTER	---
---	CONCRETE ELEVATION	---
---	PAVEMENT ELEVATION	---
---	FINISHED GRADE ELEVATION	---
---	RIM AND INVERT ELEVATION	---
---	CONTOURS	---
---	WATER FITTINGS	---
---	WATER METER	---
---	WATER LINE	---
---	FIRE HYDRANT	---
---	SEWER LINE	---
---	SEWER MANHOLE/CLEANOUT	---
---	STORM DRAIN	---
---	CATCH BASIN	---
---	UNDERGROUND STORAGE TANK	---
---	DRY WELL	---
---	GRADE BREAK/RIDGE	---
---	FLOWLINE	---
---	SLOPE	---
---	FINISHED FLOOR	---
---	GAS LINE/METER/VALVE	---
---	ELECTRIC LINE/METER	---
---	CABLE/JUNCTION BOX	---
---	COMMUNICATION LINE	---
---	OVERHEAD ELECTRIC/POLE	---
---	VEGETATION	---
---	BOUNDARY LINE	---
---	CENTER LINE	---
---	EASEMENT	---

**SURFACE BASINS INFORMATION**

BASIN	HWE	BOT	VOL (P)	VOL (R)	TOTAL VOL (P)
A	80.6	79.6	1,442	1,139	1,442
C1	81.4	81.0	803		
C2	82.5	82.0	106	1,634	1,757
C3	82.6	82.1	848		
D	82.3	79.3	37,078	21,620	37,078

**RETENTION BASIN CALCULATIONS**

Sub-Area (onsite)	Area (sf)	Area (acre)	C100	P 100 YR. 2 HR (in)	Vol. Req. (cf)	Surface Vol. Prov. (cf)	Total Tank Length Provided (LF)	Underground Vol. Prov. (cf)	Total Vol. Prov. (cf)	Excess Volume (%)	DRYWELLS
A	7,796.00	0.18	0.79	2.22	1,139.39	1,442.0	0.0	0.0	1,442.0	26.6	0
B	150,929	3.465	0.79	2.22	22,058.3	0.0	282.0	22,148.2	22,148.2	0.4	2
C	15,776	0.362	0.56	2.22	1,634.4	1,757.0	0.0	0.0	1,757.0	7.5	0
D	147,935	3.396	0.79	2.22	21,620.7	37,078.0	0.0	0.0	37,078.0	71.5	3
Total	314,640.0	7.4	-	-	46,452.8	40,277.0	282.0	22,148.2	62,425.2	34.4	5

**MEGERDICHIAN SENIOR CENTER**  
8849 E. CHOLLA ST.  
SCOTTSDALE, AZ 85260

**PRE-CONSTRUCTION PHASE**

NO.	ISSUED FOR:	DATE
1	REZONING & C.U.P.	12-13-2018
2	REZONING & C.U.P. 2nd Review	08-03-2020

**CONSTRUCTION PHASE**

REV.	BULLETIN #	DATE



**KLAND CIVIL ENGINEERS**  
CIVIL ENGINEERING  
LAND DEVELOPMENT  
SERVICES  
LAND SURVEYING  
7227 N. 16th St., Suite 217  
Phoenix, Arizona 85020  
PHONE: (480) 344-0480  
www.klandeng.com

**MASTER GRADING AND DRAINAGE PLAN**

DATE: 09/11/2020  
JOB NUMBER: 1727-00  
KLAND PROJECT NUMBER: K15153

**MGD1 OF 2**

25-ZN-2018

