



GOLD DUST APARTMENTS

Preliminary Drainage Report

Prepared For: ESG Architecture & Design

February 2, 2023

Stormwater review by Jennifer Lynch
JLynch@ScottsdaleAZ.gov
480-312-7903

DIBBLE
1122028

GOLD DUST APARTMENTS

Preliminary Drainage Report

10050 N Scottsdale Road, Paradise Valley, AZ

1122028

Prepared For: ESG Architecture & Design
Maria Ambrose
ESG Architecture & Design
500 S Washington Ave #1080
Minneapolis, MN 55415

February 2, 2023

Josh Papworth, PE
Senior Engineer
Dibble & Associates Consulting Engineers, Inc., dba Dibble





Table of Contents

1.	INTRODUCTION.....	3
1.1	PURPOSE.....	3
1.2	STUDY AREA.....	3
2.	EXISTING CONDITIONS	4
2.1	ON-SITE.....	4
2.2	OFF-SITE	4
3.	DESIGN CRITERIA.....	4
3.1	ON-SITE RAINFALL DEPTH	4
3.2	ON-SITE RAINFALL INTENSITY	4
3.3	ON-SITE RUNOFF COEFFICIENT.....	5
4.	STUDY APPROACH	5
4.1	ON-SITE HYDROLOGY & HYDRAULICS.....	5
4.2	OFF-SITE HYDROLOGY	6
4.3	OFF-SITE HYDRAULICS	7
4.4	OFF-SITE SCOUR & LATERAL MIGRATION POTENTIAL.....	8
5.	PROPOSED DRAINAGE CONDITIONS.....	9
5.1	ON-SITE.....	9
5.2	MAINTENANCE PLAN.....	10
5.3	FINSIHED FLOORS.....	10
5.4	OFF-SITE	10
6.	CONCLUSIONS	10
7.	REFERENCES	11

List of Figures

Figure 1 – VICINITY MAP	3
Figure 2 – OFFSITE HYDROLOGY RESULTS.....	7

List of Tables

Table 1 – MANNING’S N VALUES	8
Table 2 – UNNAMED CHANNEL MIGRATION POTENTIAL SUMMARY	8
Table 3 - PROPOSED DRAINAGE VOLUME SUMMARY	10

List of Equations

Equation 1 – RATIONAL METHOD.....	5
Equation 2 – REQUIRED FIRST FLUSH RETENTION VOLUME	5
Equation 3 – STORM DRAIN OUTLET CAPACITY	5
Equation 4 – BLEED OFF TIME	6
Equation 5 – TOTAL SCOUR.....	8

Appendices

Appendix A – DRAINAGE AREA MAP.....	A
Appendix B – FEMA FIRMETTE MAP	B
Appendix C – NOAA ATLAS PRECIPITATION DATA	C
Appendix D – DETAILED DRAINAGE CALCULATIONS.....	D
Appendix E – UNNAMED CHANNEL FIELD PHOTOGRAPHS.....	E
Appendix F – OFF-SITE HYDROLOGY RESULTS (LARGE FORMAT)	F
Appendix G – UNNAMED CHANNEL HYDRAULIC COMPUTATIONS.....	G
Appendix H – SCOUR AND LATERAL MIGRATION POTENTIAL CALCULATIONS.....	H



Appendix I – STORM DRAIN PROFILES I

1. INTRODUCTION

This report presents a preliminary drainage plan for the City of Scottsdale as a part of the Gold Dust Apartments project. The Gold Dust Apartments site is approximately 4.8 acres and fully developed. There is an existing wash on the west limit of the site. The project proposes a new mixed-use building and associated utility and hardscape improvements. This report presents the drainage analysis and results for the project.

The project is in the northeast quadrant of Township 3 North, Range 4 East, Section 27 and has an **Assessor's Parcel Number (APN) of 175-56-002H**. See Figure 1 for a location map.

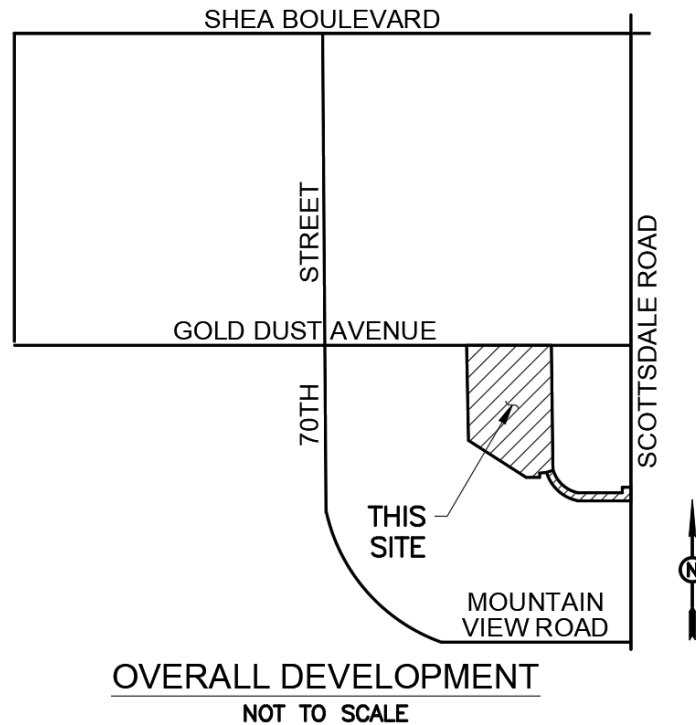


Figure 1 – VICINITY MAP

1.1 PURPOSE

The drainage analysis and design documented herein supports the zoning submittal for the ultimate buildout of Gold Dust Apartments. The design will provide drainage infrastructure to meet the City of Scottsdale and the Flood Control District of Maricopa County requirements for stormwater protection and floodplain management.

1.2 STUDY AREA

The Gold Dust Apartments project is bounded by a wash to the west of the site, existing infrastructure to the east of the site, Gold Dust Avenue to the north of the site, and residential apartment buildings to the south. On-site improvements planned for this 4.8-acre site include extensions of an existing building, hardscape improvements, and associated utility and drainage improvements, which will be discussed within this report.

2. EXISTING CONDITIONS

This site is in a **FEMA Zone 'X'**, as defined as “Areas of 0.2% annual chance flood; areas of 1% annual chance flood with average depth less than 1 foot or areas less than 1 square mile; and areas protected by levees from 1% annual chance flood.” **This hazard designation** is considered minimal, and flood insurance is not federally mandated. The FEMA Flood Insurance Rate (FIRM) panel for this area is provided in Appendix A.

2.1 ON-SITE

Currently this site is a 4.8-acre parcel that is fully developed and uses most of its land use on an existing building and parking lot. The site is generally flat with an existing wash on the west side of the site. This wash runs the entire west side of the parcel as it forces water travel from north to south. The existing surface forces water runoff to run from the northeast to the southwest of the site. There is an existing 24-inch storm drain on the southwest side of the building. This storm drain exports water straight into the existing wash that is located on the west end of the site. There is a 12-inch storm drain on the west side of the building. This storm drain also exports water straight into the existing wash that is located on the west side of the site. The existing building had three different elevations within the building as stairs led up to different sections of the building. The finished floor elevations are 1342.48 in the north end of the building, 1341.68 in the middle section of the building and 1340.78 at the southernmost end of the building. The ultimate site outfall is located at the southwestern edge of the site in the existing wash at an elevation of 1335.16.

2.2 OFF-SITE

An unnamed channel exists along the western property boundary of the site. The channel extends approximately 1000 feet downstream of the site where it joins a channel at Mountain View Road, ultimately emptying to Indian Bend Wash. The channel was designed as part of previous adjacent development and consists of a partially natural bed and banks with areas of riprap erosion control and grass and desert landscaped bank lining. As-built plans date the original channel construction as 1984, and historical aerial photography supports that modifications resulting in its current configuration took place as late as 1996. A field investigation of the wash was conducted by Dibble engineers on July 12, 2022. The wash showed few signs of instability with intermittent areas of local scour. Local scour appeared to be limited to culvert outlets and at the toes of bends on the west bank. Selected field photographs of the channel can be found in Appendix E.

3. DESIGN CRITERIA

The project is designed consistent with standards set forth in the City of Scottsdale (*DS&PM*) and the Flood Control District of Maricopa County (FDCMC) Drainage Design Manual for Maricopa County Volume I Hydrology (2018) and Volume II Hydraulics (2018) with exceptions noted herein.

Examples of specific design criteria for various design elements are provided in the following sections.

3.1 ON-SITE RAINFALL DEPTH

Rainfall depth was determined to be 0.5 inches based on the first flush retention requirement for the project.

3.2 ON-SITE RAINFALL INTENSITY

Rainfall intensities of 4.73 inches and 7.48 inches were used to analyze the capacity of the proposed system based on the 10 year, 5-min storm and the 100-year, 5-min storm respectively. Rainfall precipitation values were obtained directly from the NOAA Atlas 14 Precipitation Data Frequency Server. NOAA Atlas 14 rainfall intensities may be found in Appendix C.



3.3 ON-SITE RUNOFF COEFFICIENT

The existing site may be categorized as being fully developed with parking lot, hardscape, and structures. The runoff coefficient for paved streets, parking lots, roofs and driveways shall be 0.95, as defined by the city. For areas using desert landscaping a runoff coefficient of 0.45, as defined by the city.

4. STUDY APPROACH

4.1 ON-SITE HYDROLOGY & HYDRAULICS

Stormwater will be collected for storm drain conveyance via combination of roof drains and surface inline storm drain inlets. Surface inlets are provided to capture runoff generated from the landscape/hardscape areas. The minimum grated area opening is 24 inches. Roof drain connections are planned to convey stormwater runoff to the storm drain pipe and to the underground retention tanks, then ultimately to the existing wash. The peak flow for each inlet was calculated with Equation 1 below.

Equation 1 – RATIONAL METHOD

$$Q = CiA$$

Q = peak discharge (cubic feet per second)

C = runoff coefficient

I = average rainfall intensity (inch/hour) for duration Tc (5 minutes minimum)

A = drainage area (acres)

The storm drain model results can be seen in Appendix C.

The proposed onsite StormCapture retention tanks are concrete and are designed to store the first flush as required by the DS&PM. A Maxwell Plus dual chamber drywell is planned to dissipate basin storm water within 36 hours. The required first flush retention volume was determined by using Equation 2, and these calculations can be reviewed in Appendix D.

Equation 2 – REQUIRED FIRST FLUSH RETENTION VOLUME

$$V_R = 1 \left(\frac{P}{12} \right) A,$$

V_R = retention volume required (cubic feet)

P = 0.5 (inch), per City of Scottsdale

A = area of project, (square feet)

Storm drain outlet capacity was calculated using Equation 3 below, the overflow pipe to the wash will have a backwater valve to prevent water from the wash from entering the retention chamber. See Appendix D for provided retention volume calculations.

Equation 3 – STORM DRAIN OUTLET CAPACITY

$$Q = \left(\frac{1.49}{n} \right) * AR^{0.67} S^{0.5}$$

Q = flow rate (cubic feet per second)

A = flow area (square feet)

R = hydraulic radius (feet)

S = slope (feet/feet)

n = manning's number

Bleed off time was calculated using Equation 4 below. See Appendix D for provided retention volume calculations.

Equation 4 – BLEED OFF TIME

$$t = \left(\frac{V_R}{Q} \right) / \frac{1 \text{ hour}}{3600 \text{ s}}$$

t = bleed off time (hours)

A = retention volume provided (cubic feet)

Q = flow rate (cubic feet per second) from outlet pipe or drywell (0.1 CFS [Minimum rate per MCFCD])

4.2 OFF-SITE HYDROLOGY

The unnamed wash at the western property boundary is within the *East Shea Area Drainage Master Study/Plan* (ADMS/P) project area. A previous study, the *Lower Indian Bend Wash Area Drainage Master Study* (ADMS) included the area of the project site as well; however, the area was considered a buffer area for flow exchanged between low-resolution modeling areas and focused modeling areas. Therefore, use of the results in the buffer were advised to be used with caution, and Dibble has decided to make use of the more recent East Shea ADMS/P modeling. As of the writing of this report, all components of the East Shea ADMS modeling are complete, the models have completed multiple rounds of review by the Flood Control District of Maricopa County (FCDMC), and the hydrology is in a final review stage. For this project, Dibble has been provided the **ADMS's 2-dimensional hydrology models**, reviewed the models for appropriateness in the context of the Gold Dust Apartments project, and adopted them for use. All modeling for use in **establishing peak discharges at the Gold Dust Apartments site is being submitted under this report's seal.**

The area was modeling using the Professional Version of FLO-2D (FLO-2D PRO) (FLO-2D Software, Inc., 2018), Build No. 19.07.21, having an executable date of March 20, 2020. Dibble created a 100-year, 6-hour version of the model to ensure the greater of the 24-hour and 6-hour storm results are used for analysis and design of the unnamed wash on the site. The project is within Subdomain 1 of the East Shea ADMS/P model area and the 6-hour storm duration was found to produce the highest 100-year peak discharges at the site. Figure 2 provides maximum depth results and peak discharges at the project site. Exhibit F-1 in Appendix F provides results for all of Subdomain 1. Additional supporting documentation of the FLO-2D modeling parameters is provided with the electronic data for this report.

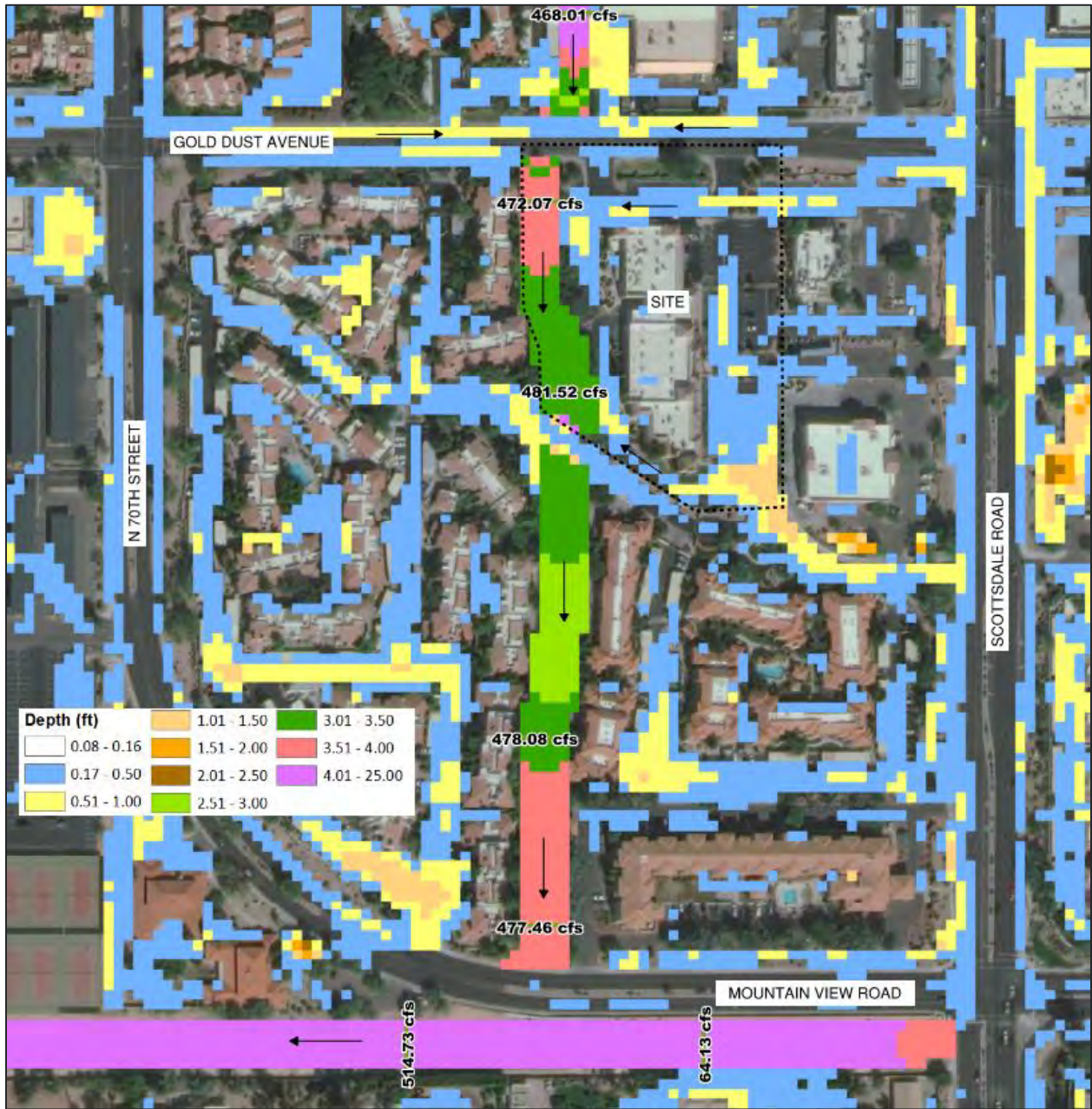


Figure 2 – OFFSITE HYDROLOGY RESULTS

4.3 OFF-SITE HYDRAULICS

Detailed, one-dimensional hydraulic modeling of the unnamed channel at the site was performed using GeoHEC-RAS v.3.1.0 software. Hydraulic modeling provided the existing condition and post-project water surface elevations at the site boundary and basis of scour and lateral migration potential computations.

Hydraulic modeling made use of field survey of the wash obtained in October of 2021. Field survey was supplemented for reaches upstream and downstream of the project site with Quality Level 1 LiDAR data, sampled to a ½ meter digital elevation model, obtained from the United States Geological Survey. Elevations provided herein are on NAVD 88 vertical datum.

Post-project hydraulic modeling included modification of cross sections for the proposed bank grading and **Manning’s roughness values were modified to represent the proposed riprap lining.**



Table 1 provides Manning’s n values selected for hydraulic modeling.

Table 1 – MANNING’S N VALUES

Ground Feature	Manning’s N Value
Wash Bed	0.035-0.040
Wash Bank – Grass Landscaping	0.035
Wash Bank - Vegetated	0.04-0.05
Riprap Lining (D50=4”)	0.040

Hydraulic modeling results, including water surface profiles, can be found in Appendix G. Water surface elevations at selected locations are provided on the Preliminary Grading and Drainage Plan.

4.4 OFF-SITE SCOUR & LATERAL MIGRATION POTENTIAL

The potential for lateral erosion at the east bank of the unnamed channel was performed in a spreadsheet and followed methodology provided in Arizona Department of Water Resources (ADWR) *State Standard Attachment 5-96 Watercourse Sediment Balance* (SSA 5-96). Bed and bank sediment samples were analyzed to provide gradations. Level II analyses were performed for both the bed and bank gradation data at each HEC-RAS cross section fronting the site. The more conservative of the results of both were used as the basis for erodibility. These calculations can be found in Appendix H. A summary of the erodibility estimate results are provided in Table 2 below. Level II analysis guidance states that if either the allowable velocity or tractive stress analysis approach support a non-erosive result, the channel may be considered non-erosive. These results support that an approximately 150-foot length of the existing channel, beginning at the downstream end of an existing concrete access ramp and extending south, is potentially erosive and has lateral migration potential during the peak of the 100-year storm event.

Table 2 – UNNAMED CHANNEL MIGRATION POTENTIAL SUMMARY

HEC-RAS CROSS SECTION	SS 5-96 LEVEL II APPROACH	
	ALLOWABLE VELOCITY	TRACTIVE STRESS ANALYSIS
1572	Erosive	Not Erosive
1496	Erosive	Erosive
1422	Erosive	Erosive
1319	Erosive	Erosive
1223	Erosive	Not Erosive
1193	Not Erosive	Not Erosive

Scour calculations were performed using post-project HEC-RAS modeling results and wash bed sample gradation. The analysis included the summation of several scour components. The following equation was used to estimate the total scour.

Equation 5 – TOTAL SCOUR

$$Z_t = FS * (Z_{\text{long-term}} + Z_{\text{general}} + Z_{\text{bend}} + Z_{\text{bedform}} + Z_{\text{low flow}} + Z_{\text{local}})$$

Where Z_t is the total design scour and FS is the factor of safety. A FS of 1.3 has been used for this condition.

Long-term scour, $Z_{\text{long-term}}$, is an estimation of the ultimate degradation of movable channel beds as they seek an equilibrium sediment transport condition. The reach is protected from long-term scour by the concrete box culvert at its downstream end. This hard point cuts off progression of long-term degradation. Also, the existing bed slope is nearly 0%. For these reasons, a value of zero was used for the long-term scour component.

General scour, Z_{general} , is the component of scour that represents the mobile portion of the bed-material of the channel bottom during the peak flow event. General scour was computed using the Blanch Equation, which is well suited to channels in which there is little or no sediment supply from the upstream reach. Upstream of Gold Dust Avenue, the wash is completely channelized with a concrete lining.

Bend scour, Z_{bend} , occurs on the outside of bends in the wash channel. The Blanch Equation for general scour accounts for a moderate bend. Therefore, this value was set to zero.

Bedform scour, Z_{bedform} , also known as dune and anti-dune scour is the component of scour caused by movement of dune shaped bed forms along the bottom of the channel and is primarily confined to sand bed washes. The bedform scour component was estimated by calculating both dune and anti-dune scour. The actual type of bedform present is a function of the flow regime. Since the flow regime may change with the fluctuating discharges of the flood hydrograph, both bedforms could be present in the project reach during a flood event. The scour component is limited to a maximum of $\frac{1}{2}$ the dune height or $\frac{1}{2}$ the flow depth.

Low-flow thalweg scour, Z_{ft} , occurs if a small wash forms to convey minor flows within the main channel of a wash cross-section. The intent of the low-flow thalweg scour component is to address a feature that sometimes forms within large washes (with bottom widths greater than the natural bank full width) with a high width to depth ratio and with mobile bed sediments. Based on field observation, a low-flow depression already exists in the wash bed, and computed scour depth was applied below this elevation. Therefore, a value of zero was used for this component.

Local scour, Z_{local} , results from an obstruction and abrupt change in the direction of flow. It occurs at bridge piers, abutments, embankments, and other structures obstructing flow. There are no local scour elements in this reach. Therefore, the value for this item was set to zero.

Scour calculations are provided in Appendix H.

5. PROPOSED DRAINAGE CONDITIONS

5.1 ON-SITE

The Gold Dust Apartments project includes a new building and associated site improvements, Existing storm drains that lead to the wash will be removed. A combination of storm drains, roof drains, and surface flow will capture the runoff and outfall into underground concrete tanks. There will also be 1 drywell implemented to meet the requirement of bleed off in 36 hours.

A total of five (5) StormCapture concrete tanks will be used. These tanks are sized at 7x15x14. The volume required from these retention tanks were determined using the first flush precipitation depth of 0.5 inches. Any water in excess of the first flush will flow into the wash via pipes or surface runoff. The east drainage area was calculated to be 91,008 square feet and produces approximately 14.84 cfs and is planned to flow into the east storm drain. The west drainage area was calculated to be 65,116 square feet and is planned to drain into the retention tanks from a drain system internal to the garage. The total site drainage area is in the table below and summarizes the drainage calculations for the total site. Within the retention tanks, a system with a single storm drain is planned to allow extra water above the first flush (0.5-inch depth) to flow into the wash. See Appendix I for storm drain profiles based on the 100 year storm, the over flow

include the scour analysis and total scour depth as how the scour will be mitigated in the report and final plans.

Include a table showing how the flow will be treated during draining.



pipe for bypass beyond first flush has not been modeled, but is sized to match the highest flow in the on-site conveyance.

Refer to Table 3 for a summary of the drainage calculations.

Table 3 - PROPOSED DRAINAGE VOLUME SUMMARY

DRAINAGE AREA	DRAINAGE AREA [SF]	VOLUME REQUIRED [CF]	VOLUME PROVIDED [CF]	BLEED OFF TIME [HR]
A	156,124	6,180	7,350.00	17.2

In the mentioned description text of

5.2 MAINTENANCE PLAN

Regular maintenance is recommended annually. Deposited silt and sediments may need to be removed from the retention tanks annually. It is recommended that the removal of sediment is to be done when levels fill up to 10 percent of the effective settling capacity.

5.3 FINISHED FLOORS

The site drainage design will provide protection of the proposed building on the site from the 100-year storm event. The lowest habitable finish floor is 1344.50, which is approximately 3.5 feet above the ultimate overland outfall of the site, and 4.44 feet above the 100-year water surface elevation (1340.06) at the north end of the building on the high end of the site. The wash will be armored to protect from lateral migration, and there is no indication of water reaching the underground parking, the walls will be waterproofed, but not floodproofed based on their distance from the wash.

5.4 OFF-SITE

Hydraulic modeling of the unnamed channel on the western site boundary supports that the 100-year design storm event is contained within the existing channel banks. Water surface elevations at selected locations are provided on the Grading and Drainage Plan. An assessment of the erodibility of the wash and potential for lateral migration supports that a 150-foot length of the existing channel, beginning at the downstream end of an existing concrete access ramp and extending south, is potentially erosive and has lateral migration potential during the peak of the 100-year storm event. At the downstream limit of the existing concrete lining, riprap erosion protection has been designed to eliminate the potential for scour of the east bank. The riprap lining follows the existing bank geometry with some smoothing of existing irregularities in the bank slope. The proposed condition maximum velocity is 5 feet per second, and a river D50 size of 4 inches has been selected. A riprap toe down of the armored bank has been designed to the **calculated total scour depth, 2.3', applied to the lowest, adjacent bed elevation. Because the designed bank toe elevation is above the lowest existing bed elevation at some locations, a consistent depth from the designed toe elevation of 3.2' provides depth to the calculated scoured depth at all locations.** The remainder of the channel was found to be non-erodible, and, therefore, no erosion setback or lining is necessary. No other modifications to the existing channel are expected.

6. CONCLUSIONS

The construction of the Gold Dust Apartments facility drainage is designed to retain the first flush runoff as part of the proposed site improvements. Flows are routed via roof drains, surface drainage and storm drain pipes to underground retention tanks and the existing wash. The drainage features associated with this project will have adequate capacity to retain the first flush and to convey the 100-year storm. The ultimate outfall is located on the southwest corner of the site over the box culvert at an elevation of 1340.56 or at the bottom of the culvert in smaller storms at 1335.16. The unnamed wash at the western site boundary



has the capacity to convey the 100-year peak discharge without overtopping its banks and riprap bank protection of erodible areas will eliminate the potential for lateral migration into the developed areas of the site.

7. REFERENCES

City of Scottsdale, *Design Standards and Policies Manual*, 2018.

Flood Control District of Maricopa County, *Drainage Design Manual for Maricopa County, Arizona, Volume I, Hydrology*, 2018.

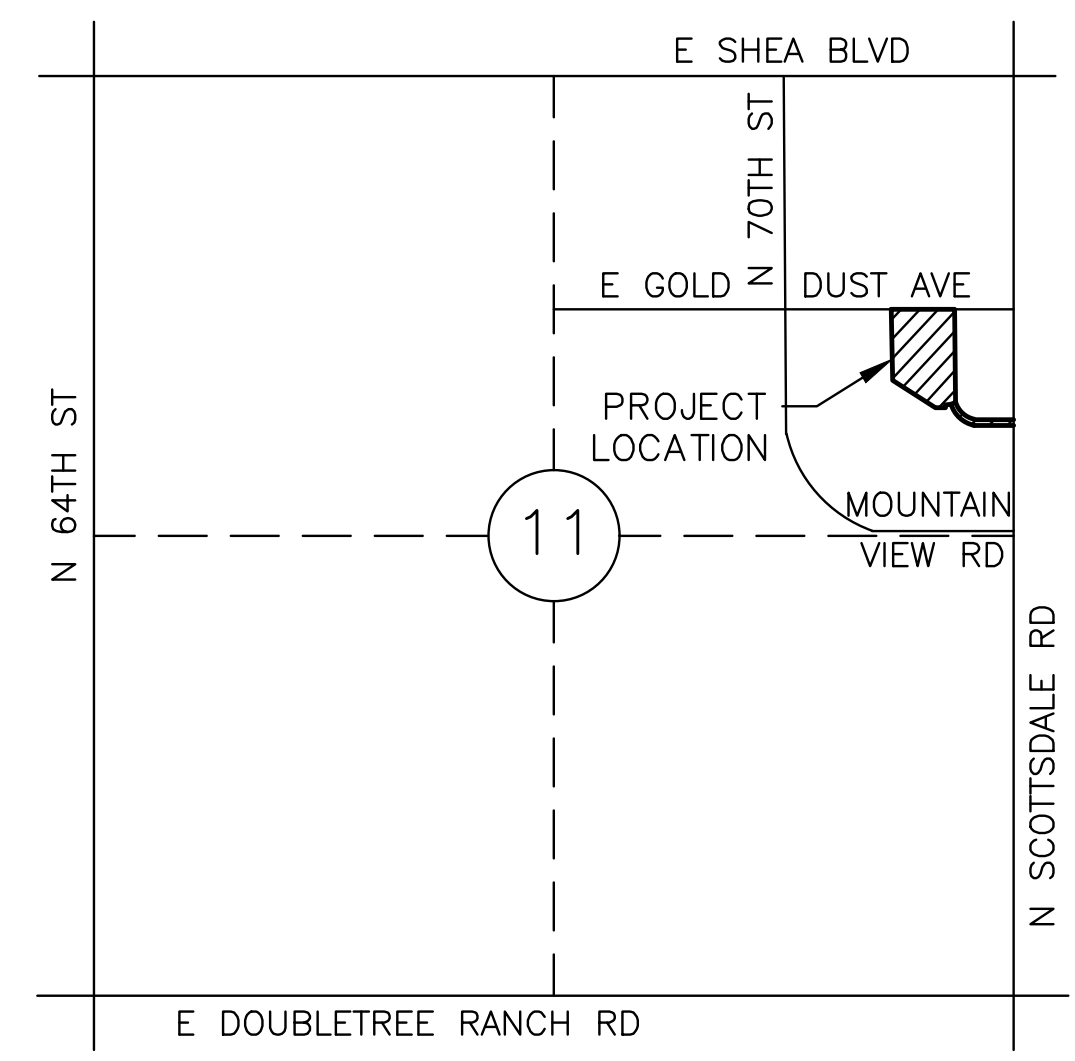
Arizona Department of Water Resources, *State Standard Attachment SSA 5-96 for Watercourse System Sediment Balance*, 1996



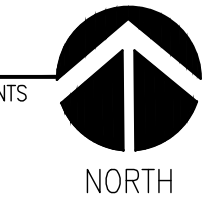
Appendix A – DRAINAGE AREA MAP



500 Washington Avenue South, Suite 1080
Minneapolis, MN 55415
p 612.339.5508 | f 612.339.5382
www.esgarch.com



VICINITY MAP
SEC 11 T3N R4E



RETENTION CALCULATIONS

DRAINAGE AREA

VOLUME REQUIRED:
 $V = C \cdot A \cdot (P/12)$
 $V = (0.95) \cdot (156,124 \text{ SF}) \cdot (0.5 \text{ IN}/12)$
 $V = 6,180 \text{ CF}$

VOLUME PROVIDED:
FIVE 14 FT TALL STORM CAPTURE RETENTION TANKS @ VOLUME PER TANK CF/TANK = 1,470 CF

TOTAL VOLUME (5) TANKS = 7,350 CF

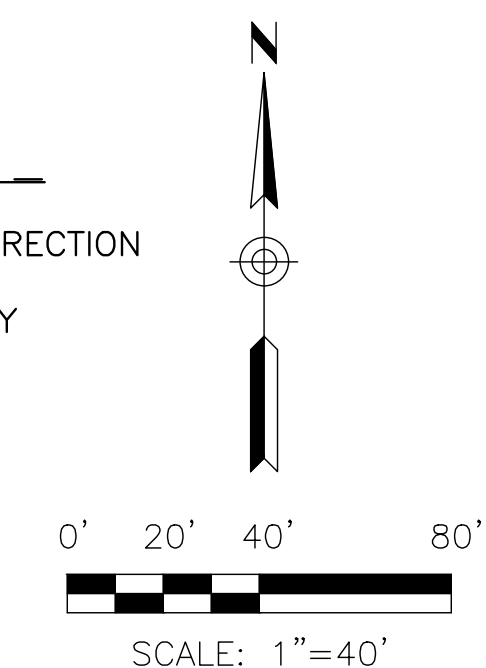
1 DRYWELLS TO DRAIN IN 17.2 HRS

NOTE:

1. ALL CURB RAMPS ON THE SUBJECT PARCEL, AND WITHIN THE PUBLIC ROW AND EASEMENTS, TO BE INVESTIGATED FOR ADA COMPLIANCE AND UPDATED ACCORDINGLY.

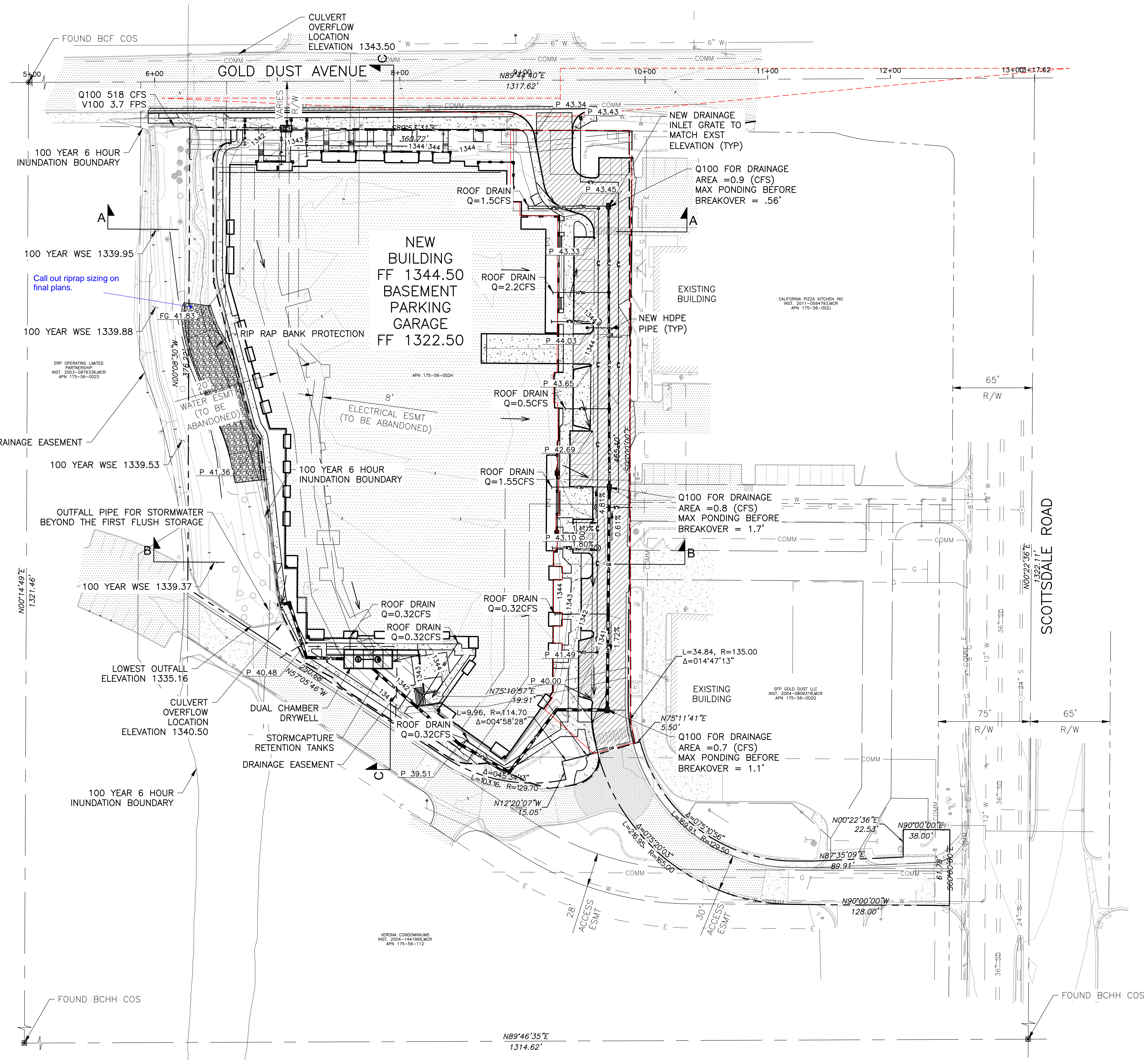
LEGEND

- ← PROPOSED FLOW DIRECTION
- - - DRAINAGE BOUNDARY

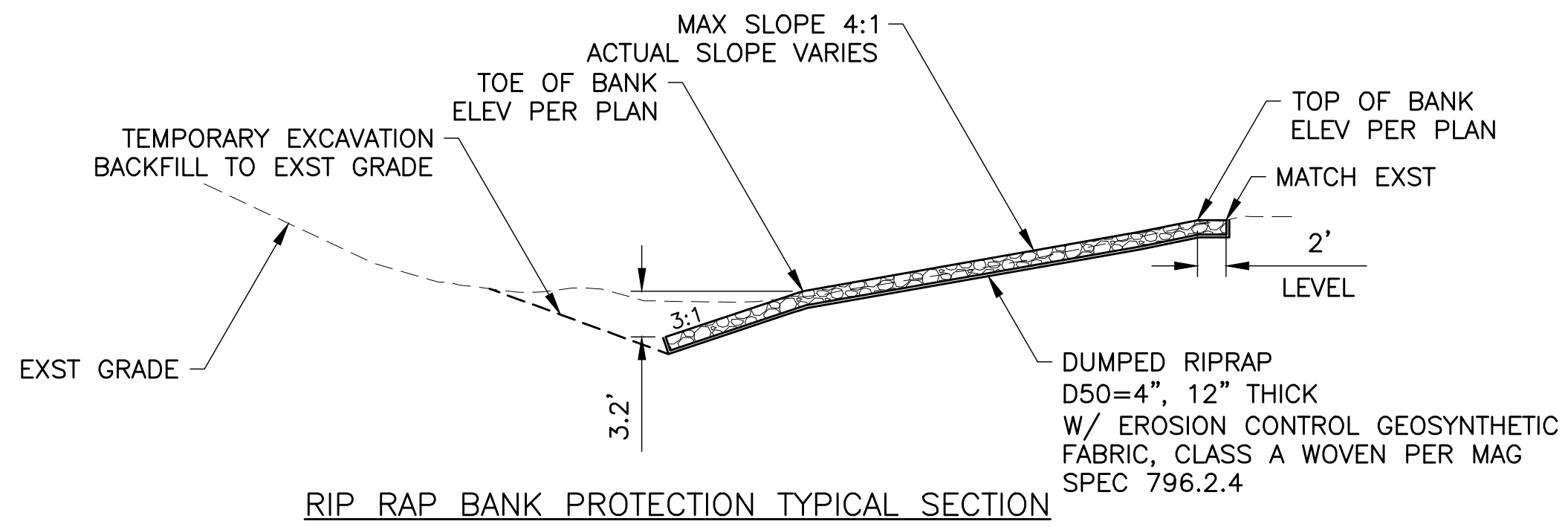


PRELIMINARY GRADING & DRAINAGE PLAN

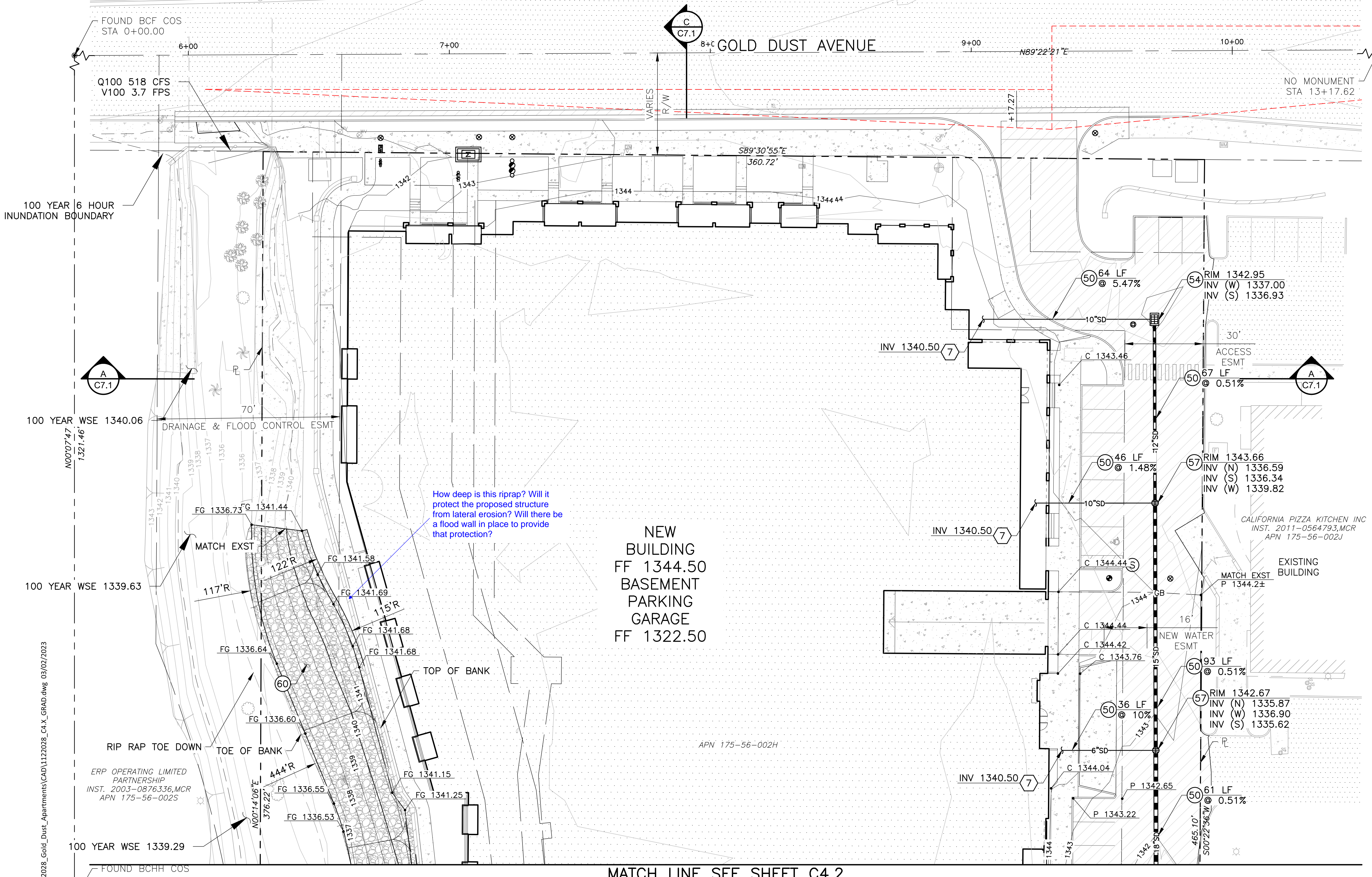
C1.1



G:\2021\112028_Gold_Dust_Apartments\CAD\112028_PRELIM SITE.dwg 03/02/2023



RIP RAP BANK PROTECTION TYPICAL SECTION



MATCH LINE SEE SHEET C4.2

- CONSTRUCTION NOTES**
- 50 STORM DRAIN, HDPE (WATER TIGHT) SIZE PER PLAN ADS N-12 WT OR APPROVED EQUAL
 - 54 DRAIN BASIN W/2'X3' MAG GRATE (H-20 TRAFFIC), DET X, SHEET X ADS NYLOPLAST OR APPROVED EQUAL
 - 57 DRAIN BASIN W/GRATED LID (H-20 TRAFFIC) DET X, SHEET X ADS NYLOPLAST OR APPROVED EQUAL
 - 60 RIP RAP BANK PROTECTION PER TYPICAL SECTION C4.1

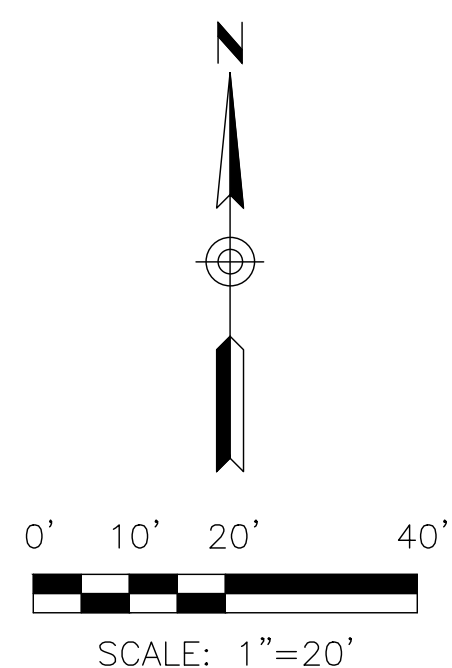
- REFERENCE NOTES**
- 7 FOR CONTINUATION REFER TO PLUMBING PLANS

- NOTES:**
1. ONLY STORM DRAIN UTILITIES SHOWN FOR CLARITY.
 2. ADD 1000' TO ALL SPOT GRADES & INVERT ELEVATIONS.
 3. ALL TOP OF CURBS ARE 6" ABOVE PAVEMENT ELEVATION UNLESS OTHERWISE NOTED.
 4. ALL UTILITY SURFACE FEATURES SHALL BE ADJUSTED TO FINISH GRADE INCLUDING BUT NOT LIMITED TO UTILITY BOXES, VALVES, METER BOXES, VAULTS, MANHOLES, BACKFLOWS, GRATES, ETC.
 5. ALL NEW SIDEWALK, PAVING AND OTHER HARDSCAPE FEATURES SHALL MATCH IN WITH EXISTING ADJACENT GRADES.
 6. ALL SIDEWALK & ADA ROUTES SHALL BE CONSTRUCTED WITH 5% MAX SLOPE IN THE DIRECTION OF TRAVEL AND 2% MAX CROSS SLOPE.

Gold Dust Ave & Scottsdale Rd
Scottsdale, AZ



500 Washington Avenue South, Suite 1080
Minneapolis, MN 55415
p 612.339.5508 | f 612.339.5382
www.esgarch.com



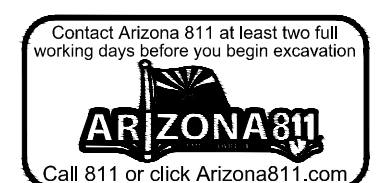
GRADING & DRAINAGE PLAN

C4.1

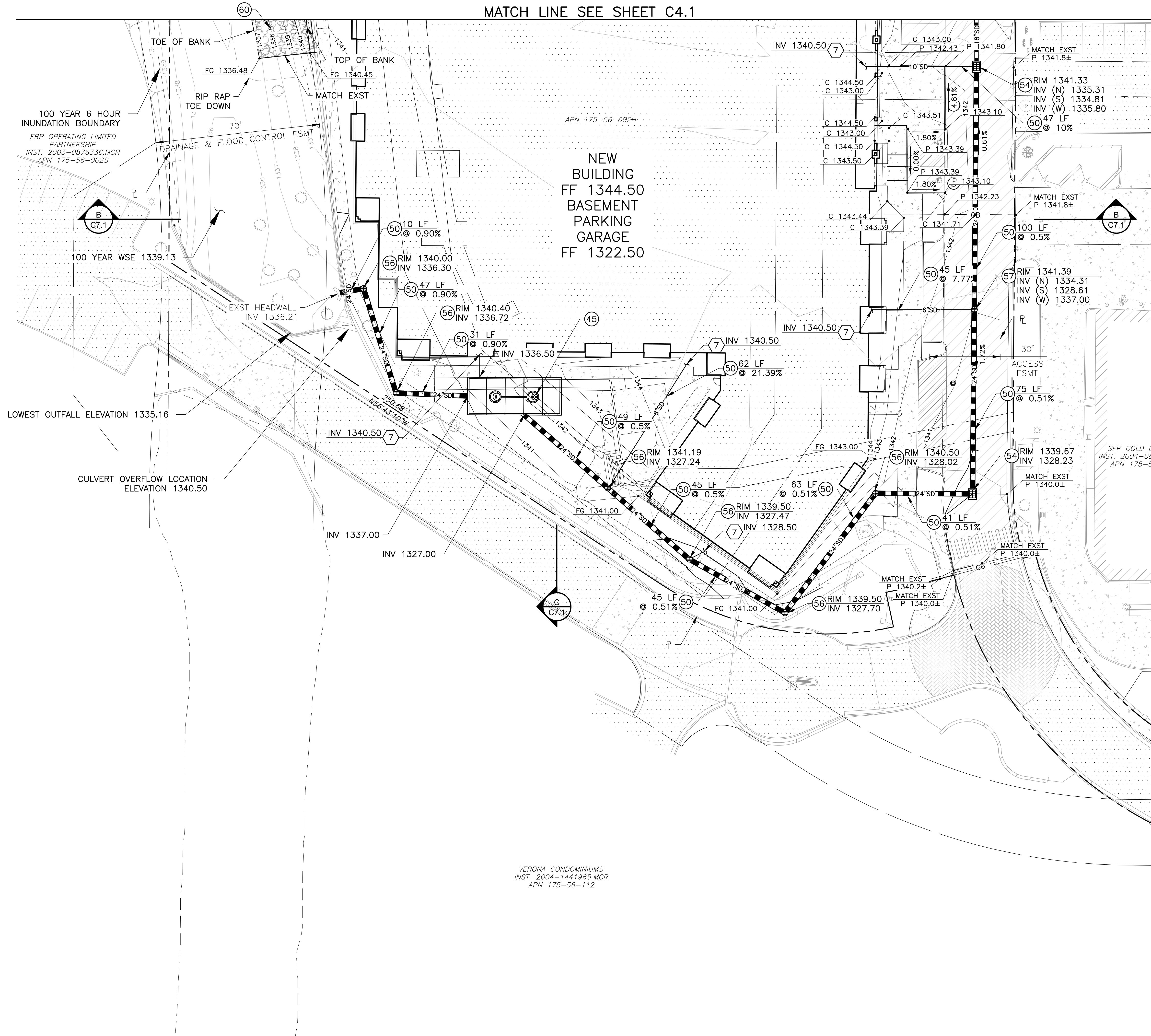
G:\2021\1122028_Gold_Dust_Apartments\CAD\1122028_C4_X_GRAD.dwg 03/02/2023

ERP OPERATING LIMITED PARTNERSHIP
INST. 2003-0876336,MCR
APN 175-56-002S

APN 175-56-002H



MATCH LINE SEE SHEET C4.1



- CONSTRUCTION NOTES**
- (45) DUAL CHAMBER DRYWELL
MAXWELL PLUS OR APPROVED EQUAL
DET X, SHEET X
 - (50) STORM DRAIN, HDPE (WATER TIGHT)
SIZE PER PLAN
ADS N-12 WT OR APPROVED EQUAL
 - (54) DRAIN BASIN W/ 2'x3' MAG. GRATE
(H-20 TRAFFIC), DET X, SHEET X
ADS NYLOPLAST OR APPROVED EQUAL
 - (56) DRAIN BASIN W/ GRATED LID (PEDESTRIAN)
DET X, SHEET X
ADS NYLOPLAST OR APPROVED EQUAL
 - (57) DRAIN BASIN W/ GRATED LID (H-20 TRAFFIC)
DET X, SHEET X
ADS NYLOPLAST OR APPROVED EQUAL
 - (60) RIP RAP BANK PROTECTION
PER TYPICAL SECTION C4.1
- Update notes in final plans.

Gold Dust Ave & Scottsdale Rd
Scottsdale, AZ

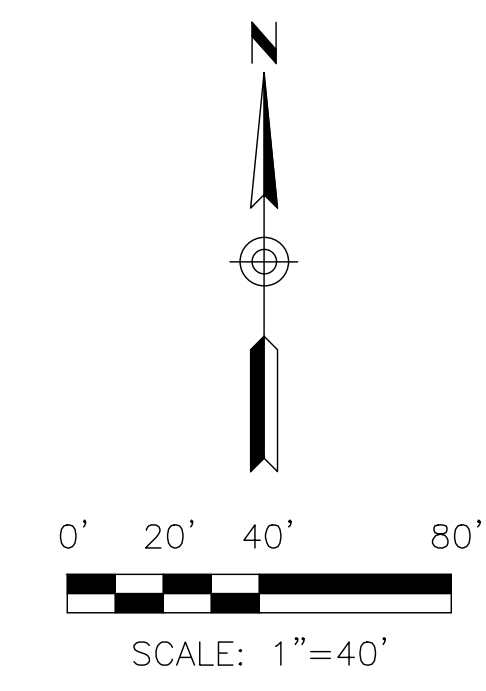
HIGH STREET
RESIDENTIAL

DIBBLE

escg
ARCHITECTURE & DESIGN

500 Washington Avenue South, Suite 1080
Minneapolis, MN 55415
p 612.339.5508 | f 612.339.5382
www.esgarch.com

- NOTES:**
1. ONLY STORM DRAIN UTILITIES SHOWN FOR CLARITY.
 2. ADD 1000' TO ALL SPOT GRADES & INVERT ELEVATIONS.
 3. ALL TOP OF CURBS ARE 6" ABOVE PAVEMENT ELEVATION UNLESS OTHERWISE NOTED.
 4. ALL UTILITY SURFACE FEATURES SHALL BE ADJUSTED TO FINISH GRADE INCLUDING BUT NOT LIMITED TO UTILITY BOXES, VALVES, METER BOXES, VAULTS, MANHOLES, BACKFLOWS, GRATES, ETC.
 5. ALL NEW SIDEWALK, PAVING AND OTHER HARDSCAPE FEATURES SHALL MATCH IN WITH EXISTING ADJACENT GRADES.
 6. ALL SIDEWALK & ADA ROUTES SHALL BE CONSTRUCTED WITH 5% MAX SLOPE IN THE DIRECTION OF TRAVEL AND 2% MAX CROSS SLOPE.



GRADING & DRAINAGE PLAN

C4.2

G:\2021\112028_Gold_Dust_Apartments\CA0\112028_C4_X_GRAD.dwg 03/02/2023

VERONA CONDOMINIUMS
INST. 2004-1441965, MCR
APN 175-56-112

100 YEAR 6 HOUR
INUNDATION BOUNDARY
ERP OPERATING LIMITED
PARTNERSHIP
INST. 2003-0876336, MCR
APN 175-56-002S

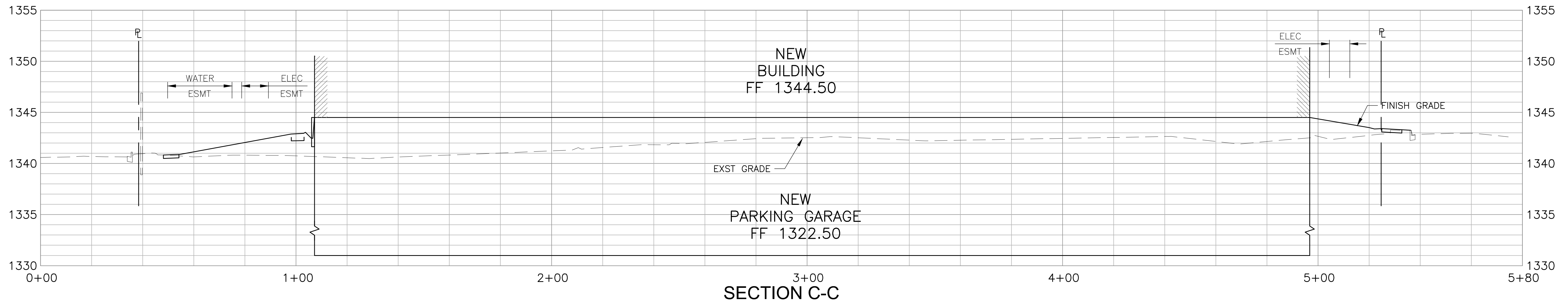
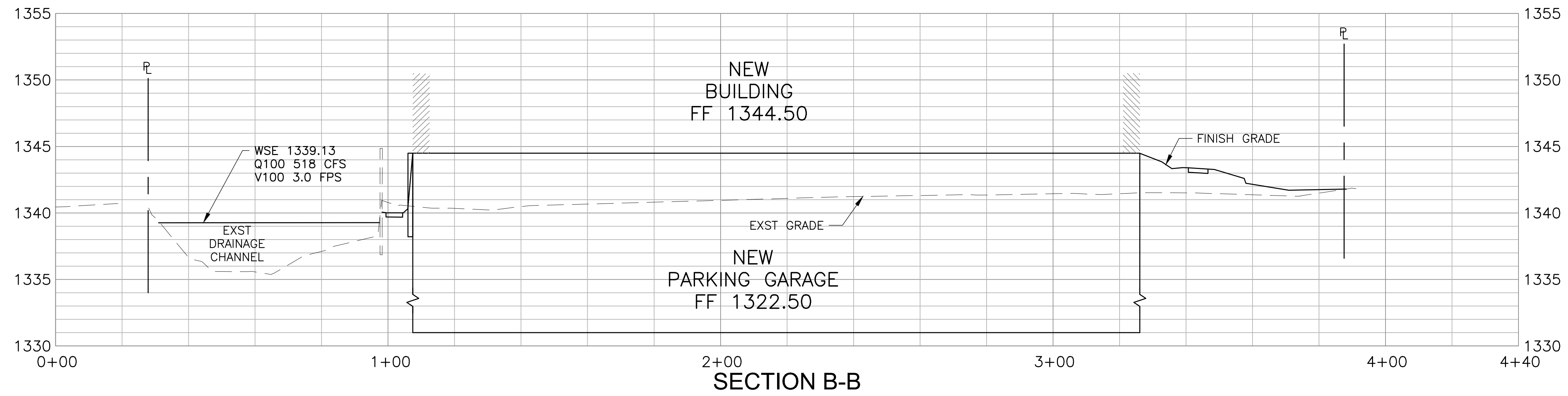
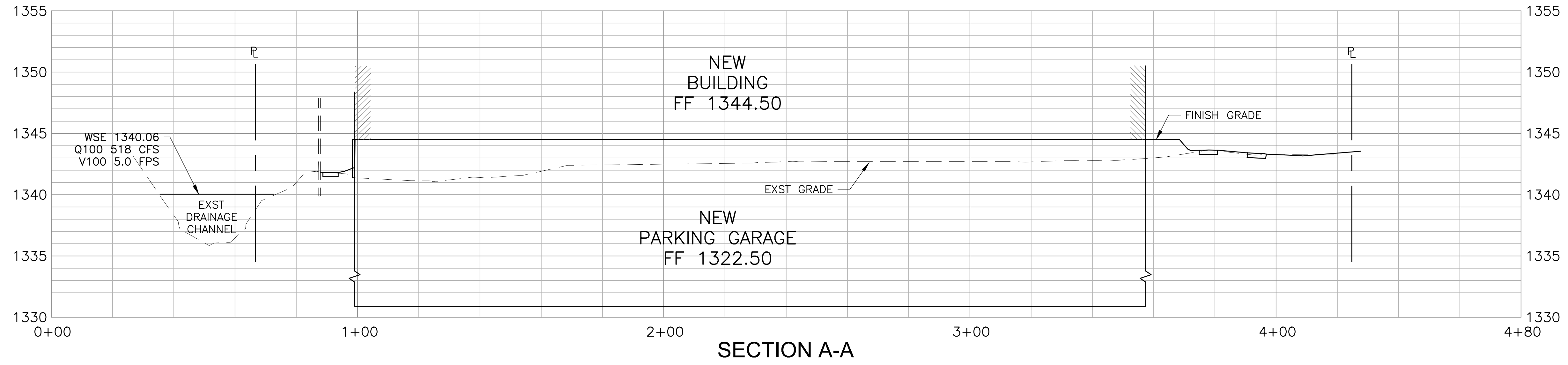
NEW
BUILDING
FF 1344.50
BASEMENT
PARKING
GARAGE
FF 1322.50

APN 175-56-002H

SFP GOLD DUST LLC
INST. 2004-0809318, MCR
APN 175-56-002Q



500 Washington Avenue South, Suite 1080
Minneapolis, MN 55415
p 612.339.5508 | f 612.339.5382
www.esgarch.com



G:\2021\112028_Gold_Dust_Apartments\CA0\112028_PRELIM\SITE.dwg 09/02/2023

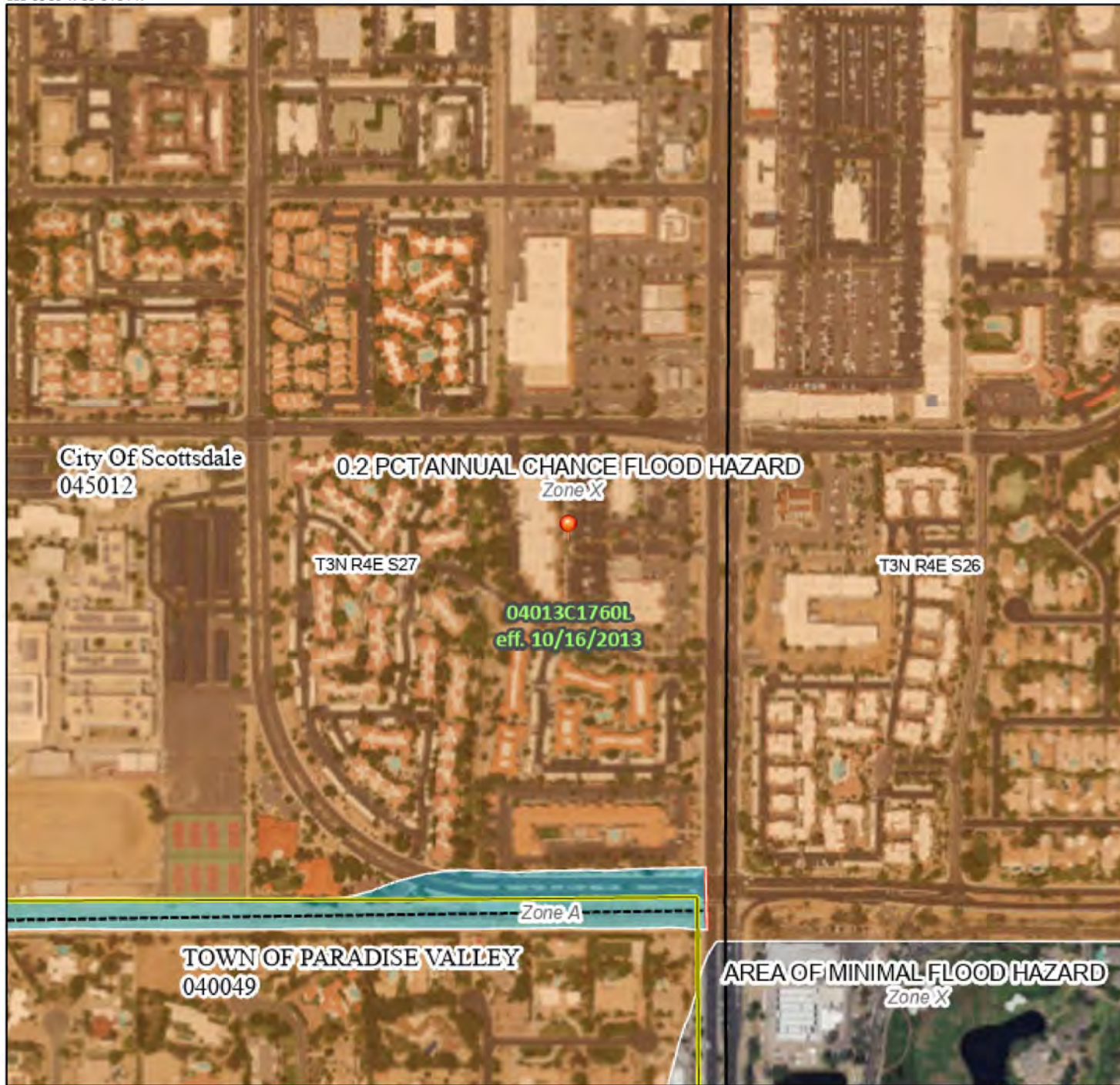


Appendix B – FEMA FIRMETTE MAP

National Flood Hazard Layer FIRMette



111°55'58"W 33°34'54"N



Legend

SEE FIS REPORT FOR DETAILED LEGEND AND INDEX MAP FOR FIRM PANEL LAYOUT

- | | | |
|------------------------------------|--|--|
| SPECIAL FLOOD HAZARD AREAS | | Without Base Flood Elevation (BFE)
<i>Zone A, V, A99</i> |
| | | With BFE or Depth <i>Zone AE, AO, AH, VE, AR</i> |
| | | Regulatory Floodway |
| OTHER AREAS OF FLOOD HAZARD | | 0.2% Annual Chance Flood Hazard, Areas of 1% annual chance flood with average depth less than one foot or with drainage areas of less than one square mile <i>Zone X</i> |
| | | Future Conditions 1% Annual Chance Flood Hazard <i>Zone X</i> |
| | | Area with Reduced Flood Risk due to Levee. See Notes. <i>Zone X</i> |
| | | Area with Flood Risk due to Levee <i>Zone D</i> |
| OTHER AREAS | | NO SCREEN Area of Minimal Flood Hazard <i>Zone X</i> |
| | | Effective LOMRs |
| GENERAL STRUCTURES | | Area of Undetermined Flood Hazard <i>Zone D</i> |
| | | Channel, Culvert, or Storm Sewer |
| | | Levee, Dike, or Floodwall |
| OTHER FEATURES | | 20.2 Cross Sections with 1% Annual Chance Water Surface Elevation |
| | | 17.5 Cross Sections with 1% Annual Chance Water Surface Elevation |
| | | Coastal Transect |
| | | Base Flood Elevation Line (BFE) |
| | | Limit of Study |
| | | Jurisdiction Boundary |
| MAP PANELS | | Coastal Transect Baseline |
| | | Profile Baseline |
| | | Hydrographic Feature |
| | | Digital Data Available |
| | | No Digital Data Available |
| | | Unmapped |
- The pin displayed on the map is an approximate point selected by the user and does not represent an authoritative property location.

0 250 500 1,000 1,500 2,000 Feet 1:6,000

111°55'20"W 33°34'24"N

Basemap: USGS National Map: Orthoimagery: Data refreshed October, 2020

This map complies with FEMA's standards for the use of digital flood maps if it is not void as described below. The basemap shown complies with FEMA's basemap accuracy standards

The flood hazard information is derived directly from the authoritative NFHL web services provided by FEMA. This map was exported on 3/17/2022 at 1:15 PM and does not reflect changes or amendments subsequent to this date and time. The NFHL and effective information may change or become superseded by new data over time.

This map image is void if the one or more of the following map elements do not appear: basemap imagery, flood zone labels, legend, scale bar, map creation date, community identifiers, FIRM panel number, and FIRM effective date. Map images for unmapped and unmodernized areas cannot be used for regulatory purposes.



Appendix C – NOAA ATLAS PRECIPITATION DATA



NOAA Atlas 14, Volume 1, Version 5
Location name: Paradise Valley, Arizona, USA*
Latitude: 33.5777°, Longitude: -111.9277°
Elevation: 1341.56 ft**



* source: ESRI Maps
 ** source: USGS

POINT PRECIPITATION FREQUENCY ESTIMATES

Sanja Perica, Sarah Dietz, Sarah Heim, Lillian Hiner, Kazungu Maitaria, Deborah Martin, Sandra Pavlovic, Ishani Roy, Carl Trypaluk, Dale Unruh, Fenglin Yan, Michael Yekta, Tan Zhao, Geoffrey Bonnin, Daniel Brewer, Li-Chuan Chen, Tye Parzybok, John Yarchoan

NOAA, National Weather Service, Silver Spring, Maryland

[PF_tabular](#) | [PF_graphical](#) | [Maps_&_aerials](#)

DEPTH

PF tabular

PDS-based point precipitation frequency estimates with 90% confidence intervals (in inches)¹										
Duration	Average recurrence interval (years)									
	1	2	5	10	25	50	100	200	500	1000
5-min	0.186 (0.155-0.227)	0.243 (0.203-0.297)	0.328 (0.272-0.400)	0.394 (0.325-0.479)	0.483 (0.392-0.585)	0.551 (0.443-0.664)	0.623 (0.491-0.748)	0.694 (0.537-0.832)	0.790 (0.596-0.949)	0.863 (0.638-1.04)
10-min	0.283 (0.235-0.346)	0.369 (0.309-0.452)	0.499 (0.414-0.609)	0.600 (0.495-0.729)	0.736 (0.597-0.891)	0.840 (0.674-1.01)	0.948 (0.747-1.14)	1.06 (0.818-1.27)	1.20 (0.908-1.44)	1.31 (0.972-1.58)
15-min	0.351 (0.292-0.429)	0.458 (0.383-0.560)	0.619 (0.514-0.755)	0.743 (0.614-0.904)	0.912 (0.741-1.11)	1.04 (0.835-1.25)	1.18 (0.926-1.41)	1.31 (1.01-1.57)	1.49 (1.13-1.79)	1.63 (1.21-1.96)
30-min	0.473 (0.393-0.578)	0.617 (0.516-0.755)	0.834 (0.692-1.02)	1.00 (0.827-1.22)	1.23 (0.997-1.49)	1.40 (1.13-1.69)	1.58 (1.25-1.90)	1.76 (1.37-2.11)	2.01 (1.52-2.41)	2.19 (1.62-2.64)
60-min	0.585 (0.486-0.715)	0.763 (0.639-0.934)	1.03 (0.856-1.26)	1.24 (1.02-1.51)	1.52 (1.23-1.84)	1.74 (1.39-2.09)	1.96 (1.54-2.35)	2.18 (1.69-2.62)	2.49 (1.88-2.98)	2.71 (2.01-3.26)
2-hr	0.684 (0.577-0.817)	0.884 (0.749-1.06)	1.18 (0.992-1.41)	1.41 (1.17-1.67)	1.72 (1.42-2.03)	1.95 (1.59-2.30)	2.19 (1.75-2.58)	2.44 (1.92-2.87)	2.77 (2.13-3.26)	3.03 (2.27-3.58)
3-hr	0.762 (0.643-0.930)	0.977 (0.827-1.20)	1.28 (1.08-1.56)	1.52 (1.26-1.84)	1.85 (1.52-2.23)	2.12 (1.72-2.53)	2.39 (1.91-2.86)	2.68 (2.10-3.20)	3.08 (2.34-3.68)	3.40 (2.52-4.07)
6-hr	0.918 (0.789-1.09)	1.16 (0.997-1.38)	1.48 (1.27-1.75)	1.74 (1.47-2.04)	2.09 (1.75-2.44)	2.36 (1.95-2.75)	2.65 (2.15-3.08)	2.94 (2.34-3.43)	3.34 (2.59-3.89)	3.65 (2.77-4.26)
12-hr	1.02 (0.878-1.19)	1.28 (1.11-1.51)	1.62 (1.39-1.90)	1.88 (1.61-2.20)	2.24 (1.90-2.61)	2.51 (2.10-2.92)	2.80 (2.30-3.25)	3.08 (2.51-3.58)	3.46 (2.75-4.04)	3.76 (2.93-4.42)
24-hr	1.19 (1.03-1.39)	1.51 (1.31-1.77)	1.95 (1.69-2.29)	2.30 (1.99-2.69)	2.78 (2.39-3.25)	3.16 (2.70-3.69)	3.56 (3.01-4.16)	3.97 (3.33-4.64)	4.54 (3.75-5.30)	4.99 (4.07-5.84)
2-day	1.28 (1.11-1.49)	1.63 (1.42-1.90)	2.13 (1.85-2.49)	2.54 (2.19-2.95)	3.09 (2.65-3.59)	3.54 (3.01-4.10)	4.00 (3.38-4.65)	4.48 (3.76-5.22)	5.16 (4.26-6.01)	5.70 (4.65-6.65)
3-day	1.36 (1.19-1.58)	1.74 (1.52-2.02)	2.29 (1.99-2.65)	2.73 (2.37-3.16)	3.35 (2.88-3.87)	3.84 (3.29-4.44)	4.37 (3.71-5.05)	4.92 (4.14-5.70)	5.70 (4.73-6.59)	6.32 (5.20-7.34)
4-day	1.45 (1.27-1.67)	1.85 (1.62-2.14)	2.45 (2.13-2.82)	2.92 (2.54-3.37)	3.60 (3.11-4.15)	4.15 (3.56-4.78)	4.74 (4.04-5.45)	5.36 (4.53-6.18)	6.23 (5.20-7.18)	6.95 (5.74-8.03)
7-day	1.64 (1.42-1.90)	2.09 (1.82-2.42)	2.77 (2.40-3.20)	3.31 (2.86-3.83)	4.08 (3.51-4.72)	4.70 (4.02-5.43)	5.36 (4.55-6.19)	6.07 (5.10-7.02)	7.06 (5.86-8.16)	7.86 (6.46-9.10)
10-day	1.76 (1.54-2.03)	2.26 (1.97-2.60)	2.98 (2.59-3.43)	3.56 (3.08-4.09)	4.37 (3.77-5.02)	5.02 (4.31-5.76)	5.72 (4.87-6.56)	6.44 (5.45-7.41)	7.47 (6.23-8.58)	8.29 (6.85-9.54)
20-day	2.17 (1.91-2.50)	2.80 (2.45-3.21)	3.70 (3.24-4.24)	4.38 (3.82-5.01)	5.30 (4.60-6.05)	6.00 (5.19-6.85)	6.71 (5.78-7.69)	7.44 (6.37-8.53)	8.42 (7.15-9.68)	9.18 (7.74-10.6)
30-day	2.55 (2.22-2.92)	3.28 (2.87-3.76)	4.32 (3.77-4.94)	5.12 (4.46-5.84)	6.18 (5.36-7.06)	7.00 (6.05-7.98)	7.84 (6.74-8.94)	8.70 (7.44-9.89)	9.85 (8.36-11.2)	10.7 (9.04-12.3)
45-day	2.93 (2.58-3.34)	3.78 (3.32-4.31)	4.97 (4.37-5.66)	5.86 (5.14-6.67)	7.03 (6.14-8.00)	7.91 (6.88-9.00)	8.80 (7.61-10.0)	9.69 (8.35-11.0)	10.9 (9.29-12.4)	11.7 (9.98-13.4)
60-day	3.22 (2.85-3.66)	4.16 (3.67-4.72)	5.47 (4.83-6.20)	6.43 (5.65-7.28)	7.67 (6.73-8.68)	8.59 (7.50-9.72)	9.51 (8.27-10.8)	10.4 (9.02-11.8)	11.6 (9.98-13.2)	12.5 (10.7-14.2)

¹ Precipitation frequency (PF) estimates in this table are based on frequency analysis of partial duration series (PDS). Numbers in parenthesis are PF estimates at lower and upper bounds of the 90% confidence interval. The probability that precipitation frequency estimates (for a given duration and average recurrence interval) will be greater than the upper bound (or less than the lower bound) is 5%. Estimates at upper bounds are not checked against probable maximum precipitation (PMP) estimates and may be higher than currently valid PMP values. Please refer to NOAA Atlas 14 document for more information.

[Back to Top](#)

PF graphical



POINT PRECIPITATION FREQUENCY ESTIMATES

Sanja Perica, Sarah Dietz, Sarah Heim, Lillian Hiner, Kazungu Maitaria, Deborah Martin, Sandra Pavlovic, Ishani Roy, Carl Trypaluk, Dale Unruh, Fenglin Yan, Michael Yekta, Tan Zhao, Geoffrey Bonnin, Daniel Brewer, Li-Chuan Chen, Tye Parzybok, John Yarchoan

NOAA, National Weather Service, Silver Spring, Maryland

[PF_tabular](#) | [PF_graphical](#) | [Maps_&_aerials](#)

INTENSITY

PF tabular

PDS-based point precipitation frequency estimates with 90% confidence intervals (in inches/hour) ¹										
Duration	Average recurrence interval (years)									
	1	2	5	10	25	50	100	200	500	1000
5-min	2.23 (1.86-2.72)	2.92 (2.44-3.56)	3.94 (3.26-4.80)	4.73 (3.90-5.75)	5.80 (4.70-7.02)	6.61 (5.32-7.97)	7.48 (5.89-8.98)	8.33 (6.44-9.98)	9.48 (7.15-11.4)	10.4 (7.66-12.5)
10-min	1.70 (1.41-2.08)	2.21 (1.85-2.71)	2.99 (2.48-3.65)	3.60 (2.97-4.37)	4.42 (3.58-5.35)	5.04 (4.04-6.07)	5.69 (4.48-6.83)	6.34 (4.91-7.60)	7.22 (5.45-8.66)	7.88 (5.83-9.47)
15-min	1.40 (1.17-1.72)	1.83 (1.53-2.24)	2.48 (2.06-3.02)	2.97 (2.46-3.62)	3.65 (2.96-4.42)	4.16 (3.34-5.01)	4.70 (3.70-5.64)	5.24 (4.06-6.28)	5.96 (4.50-7.16)	6.51 (4.82-7.83)
30-min	0.946 (0.786-1.16)	1.23 (1.03-1.51)	1.67 (1.38-2.03)	2.00 (1.65-2.44)	2.46 (1.99-2.98)	2.80 (2.25-3.37)	3.17 (2.49-3.80)	3.53 (2.73-4.23)	4.02 (3.03-4.82)	4.39 (3.24-5.27)
60-min	0.585 (0.486-0.715)	0.763 (0.639-0.934)	1.03 (0.856-1.26)	1.24 (1.02-1.51)	1.52 (1.23-1.84)	1.74 (1.39-2.09)	1.96 (1.54-2.35)	2.18 (1.69-2.62)	2.49 (1.88-2.98)	2.71 (2.01-3.26)
2-hr	0.342 (0.288-0.408)	0.442 (0.374-0.530)	0.590 (0.496-0.702)	0.702 (0.586-0.836)	0.858 (0.708-1.01)	0.974 (0.793-1.15)	1.10 (0.876-1.29)	1.22 (0.958-1.43)	1.39 (1.06-1.63)	1.51 (1.14-1.79)
3-hr	0.254 (0.214-0.310)	0.325 (0.275-0.399)	0.425 (0.358-0.518)	0.505 (0.421-0.611)	0.616 (0.506-0.741)	0.705 (0.571-0.843)	0.797 (0.634-0.953)	0.894 (0.700-1.07)	1.03 (0.779-1.23)	1.13 (0.840-1.36)
6-hr	0.153 (0.132-0.182)	0.194 (0.166-0.230)	0.247 (0.212-0.292)	0.291 (0.246-0.341)	0.349 (0.292-0.408)	0.395 (0.325-0.460)	0.442 (0.359-0.514)	0.491 (0.391-0.572)	0.557 (0.433-0.649)	0.610 (0.462-0.711)
12-hr	0.084 (0.073-0.099)	0.106 (0.092-0.125)	0.134 (0.116-0.157)	0.156 (0.134-0.183)	0.186 (0.157-0.217)	0.209 (0.174-0.242)	0.232 (0.191-0.269)	0.256 (0.208-0.297)	0.288 (0.228-0.335)	0.312 (0.243-0.367)
24-hr	0.050 (0.043-0.058)	0.063 (0.055-0.074)	0.081 (0.070-0.095)	0.096 (0.083-0.112)	0.116 (0.100-0.136)	0.132 (0.112-0.154)	0.148 (0.125-0.173)	0.165 (0.139-0.193)	0.189 (0.156-0.221)	0.208 (0.170-0.243)
2-day	0.027 (0.023-0.031)	0.034 (0.030-0.040)	0.044 (0.039-0.052)	0.053 (0.046-0.061)	0.064 (0.055-0.075)	0.074 (0.063-0.085)	0.083 (0.070-0.097)	0.093 (0.078-0.109)	0.107 (0.089-0.125)	0.119 (0.097-0.139)
3-day	0.019 (0.017-0.022)	0.024 (0.021-0.028)	0.032 (0.028-0.037)	0.038 (0.033-0.044)	0.047 (0.040-0.054)	0.053 (0.046-0.062)	0.061 (0.052-0.070)	0.068 (0.058-0.079)	0.079 (0.066-0.092)	0.088 (0.072-0.102)
4-day	0.015 (0.013-0.017)	0.019 (0.017-0.022)	0.025 (0.022-0.029)	0.030 (0.026-0.035)	0.038 (0.032-0.043)	0.043 (0.037-0.050)	0.049 (0.042-0.057)	0.056 (0.047-0.064)	0.065 (0.054-0.075)	0.072 (0.060-0.084)
7-day	0.010 (0.008-0.011)	0.012 (0.011-0.014)	0.016 (0.014-0.019)	0.020 (0.017-0.023)	0.024 (0.021-0.028)	0.028 (0.024-0.032)	0.032 (0.027-0.037)	0.036 (0.030-0.042)	0.042 (0.035-0.049)	0.047 (0.038-0.054)
10-day	0.007 (0.006-0.008)	0.009 (0.008-0.011)	0.012 (0.011-0.014)	0.015 (0.013-0.017)	0.018 (0.016-0.021)	0.021 (0.018-0.024)	0.024 (0.020-0.027)	0.027 (0.023-0.031)	0.031 (0.026-0.036)	0.035 (0.029-0.040)
20-day	0.005 (0.004-0.005)	0.006 (0.005-0.007)	0.008 (0.007-0.009)	0.009 (0.008-0.010)	0.011 (0.010-0.013)	0.012 (0.011-0.014)	0.014 (0.012-0.016)	0.016 (0.013-0.018)	0.018 (0.015-0.020)	0.019 (0.016-0.022)
30-day	0.004 (0.003-0.004)	0.005 (0.004-0.005)	0.006 (0.005-0.007)	0.007 (0.006-0.008)	0.009 (0.007-0.010)	0.010 (0.008-0.011)	0.011 (0.009-0.012)	0.012 (0.010-0.014)	0.014 (0.012-0.016)	0.015 (0.013-0.017)
45-day	0.003 (0.002-0.003)	0.003 (0.003-0.004)	0.005 (0.004-0.005)	0.005 (0.005-0.006)	0.007 (0.006-0.007)	0.007 (0.006-0.008)	0.008 (0.007-0.009)	0.009 (0.008-0.010)	0.010 (0.009-0.011)	0.011 (0.009-0.012)
60-day	0.002 (0.002-0.003)	0.003 (0.003-0.003)	0.004 (0.003-0.004)	0.004 (0.004-0.005)	0.005 (0.005-0.006)	0.006 (0.005-0.007)	0.007 (0.006-0.007)	0.007 (0.006-0.008)	0.008 (0.007-0.009)	0.009 (0.007-0.010)

¹ Precipitation frequency (PF) estimates in this table are based on frequency analysis of partial duration series (PDS). Numbers in parenthesis are PF estimates at lower and upper bounds of the 90% confidence interval. The probability that precipitation frequency estimates (for a given duration and average recurrence interval) will be greater than the upper bound (or less than the lower bound) is 5%. Estimates at upper bounds are not checked against probable maximum precipitation (PMP) estimates and may be higher than currently valid PMP values. Please refer to NOAA Atlas 14 document for more information.

[Back to Top](#)

PF graphical



Appendix D – DETAILED DRAINAGE CALCULATIONS



Gold Dust Apartments
DIBBLE PROJECT NO. 1122028
ON-SITE DRAINAGE CALCULATIONS

DES: CWD

DATE: 2022-0324

HYDROLOGY CALCULATIONS

DRAINAGE AREA	TOTAL AREA [SF]	WEIGHTED COEFFICIENT	*RAINFALL DEPTH [IN]	VOLUME REQUIRED [CF]
A	156,124	0.95	0.50	6,180
TOTAL	156,124			6,180

UNDERGROUND RETENTION

REQUIRED VOLUME [CF]	MODULE HEIGHT [FT]	MODULES REQUIRED	MODULES PROVIDED	TOTAL VOLUME [CF]	NUMBER OF DRYWELLS	DRAIN TIME [HR]
6,179.9	14.0	4.2	5.0	7,350		
TOTAL				7,350	1	17.2
**Assumed Drywell Percolation Rate [CFS]:				0.10		

$$No. of Drywells Required = \frac{Volume\ Required\ [CF]}{Percolation\ Rate\ [CFS]} * \frac{1\ hour}{3600\ seconds} * \frac{1}{Allowable\ Drain\ Time\ [hrs]}$$

STORMCAPTURE SPECS

MIN HEIGHT [FT]	MAX HEIGHT [FT]	MODULE WIDTH [FT]	MODULE LENGTH [FT]	MAX MODULE VOLUME [CF]
2.0	14.0	7.0	15.0	1,470



Appendix E – UNNAMED CHANNEL FIELD PHOTOGRAPHS



Photo 1: Looking North, upstream of Unnamed Wash. The channels material is shotcrete. Trash and other debris can be seen in the main channel.



Photo 2: Looking South, downstream of Unnamed Wash. Three box culverts are used to convey runoff under Gold Dust Avenue. Note the debris and sediment in each of the culverts.



Photo 3: Looking North, upstream of Unnamed Wash. Outlet side of the culverts passing under Gold Dust Avenue.



Photo 4: Looking South, downstream of Unnamed Wash. The channel banks are lined with grass and thick vegetation. The main flow channel has large rock and little vegetation growth.



Photo 5: Looking South, downstream of Unnamed Wash. Four box culverts convey runoff under a private driveway. Note the sediment and debris collected in the culverts.



Photo 6: Looking South, downstream of Unnamed Wash. Outlet side of the four box culverts.



Photo 7: Looking South, downstream of Unnamed Wash. The banks are lined with gravel and grass. The main flow channel is gravel and has some vegetation obstructions.



Photo 8: Looking North, upstream of Unnamed Wash. The vegetation gets denser. The other conditions remain the same.



Photo 9: Looking South, downstream of Unnamed Wash. Three box culverts convey runoff under Mountain View Road.



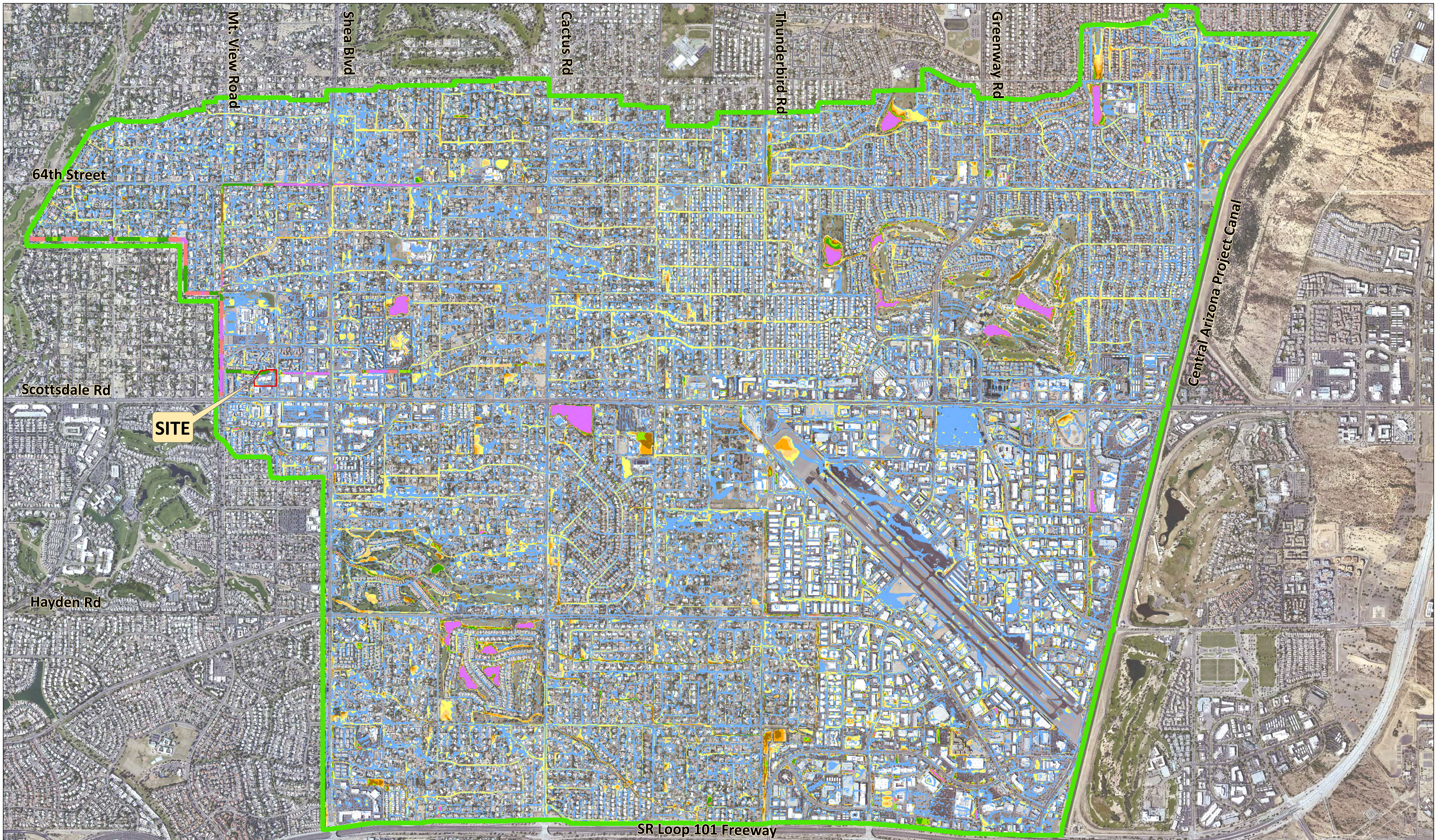
Photo 10: Looking North, upstream of Unnamed Wash. The outlet side of the three box culverts passing under Mountain View Road.



Photo 11: Looking West, downstream of outlet wash of Unnamed Wash.



Appendix F – OFF-SITE HYDROLOGY RESULTS (LARGE FORMAT)



SITE














	Domain Boundary		Depth (ft)		1.01 - 1.50		3.01 - 3.50
	Site Boundary		0.08 - 0.16		1.51 - 2.00		3.51 - 4.00
			0.17 - 0.50		2.01 - 2.50		4.01 - 25.00
			0.51 - 1.00		2.51 - 3.00		

Exhibit F-1

100-yr, 6-hr Storm, FLO-2D Maximum Depth

State the study this information is from.

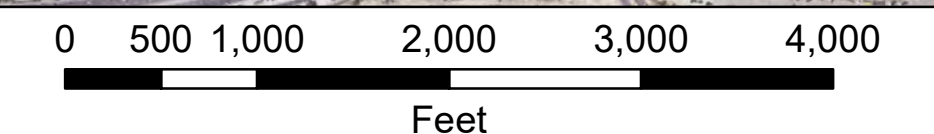


Exhibit F-1:100-yr, 6-hr Storm, FLO-2D Peak Discharge

Date Saved: 9/1/2022 6:49:04 PM



Appendix G – UNNAMED CHANNEL HYDRAULIC COMPUTATIONS



Legend	
●	BANK STATION
---	RIVER REACH
	ROADWAY CROSSING
	CROSS SECTION W/ RIVER STATION
	100 YR INUNDATION

GOLD DUST APARTMENTS - UNNAMED CHANNEL

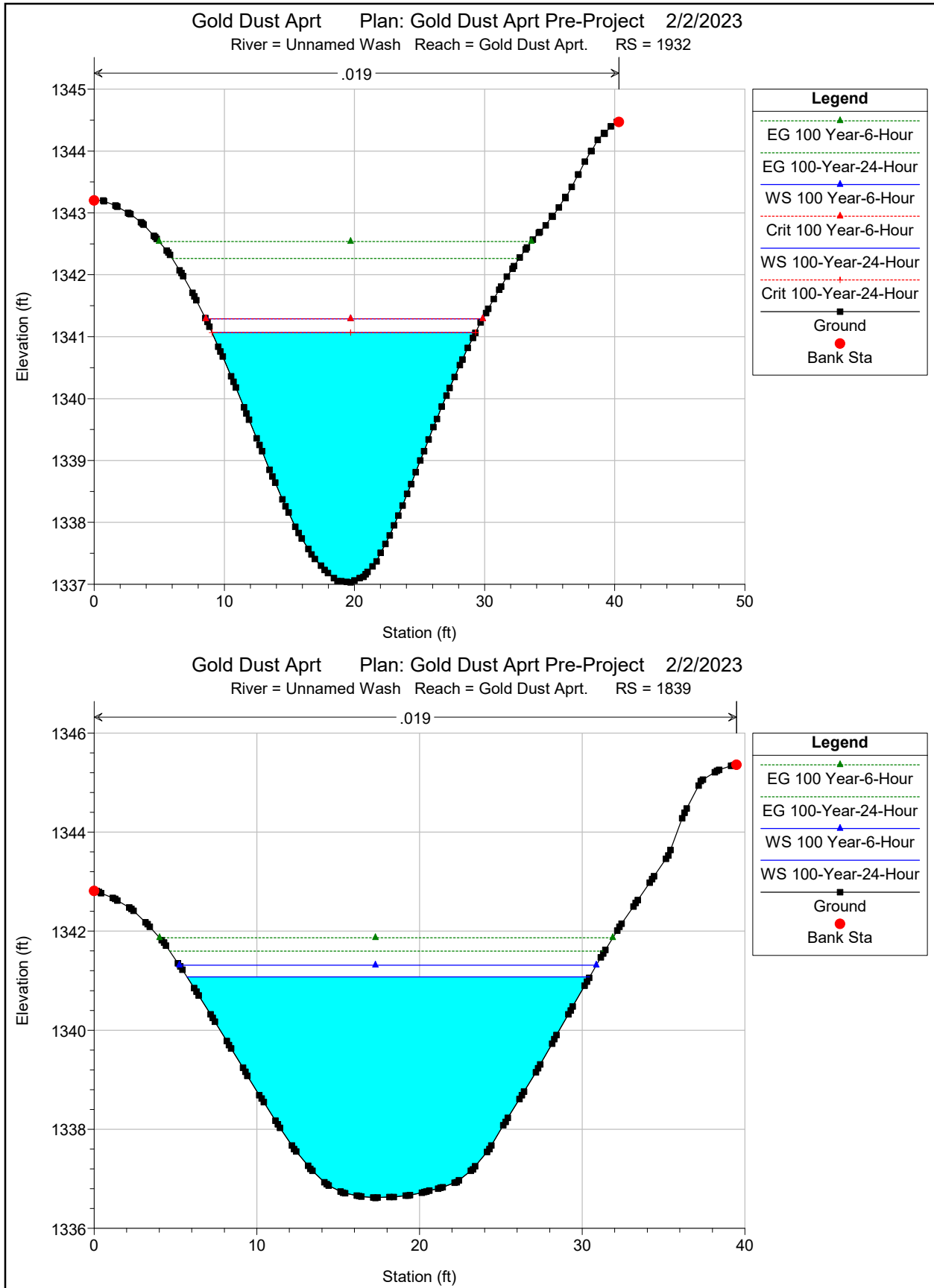
**Exhibit G-1
Existing Condition 100 Year Inundation**



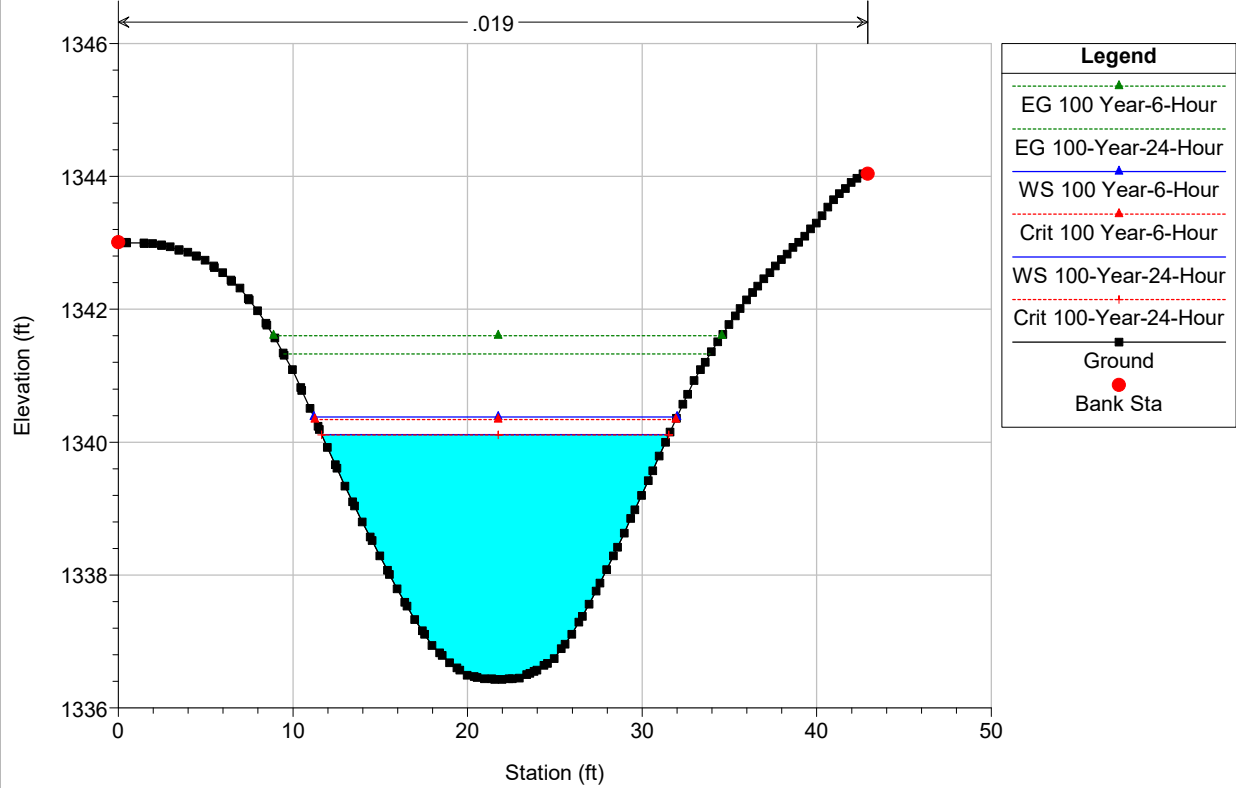
Exhibit G-1: Existing Condition 100 Year Inundation

Date Saved: 2/2/2023 1:10:38 PM

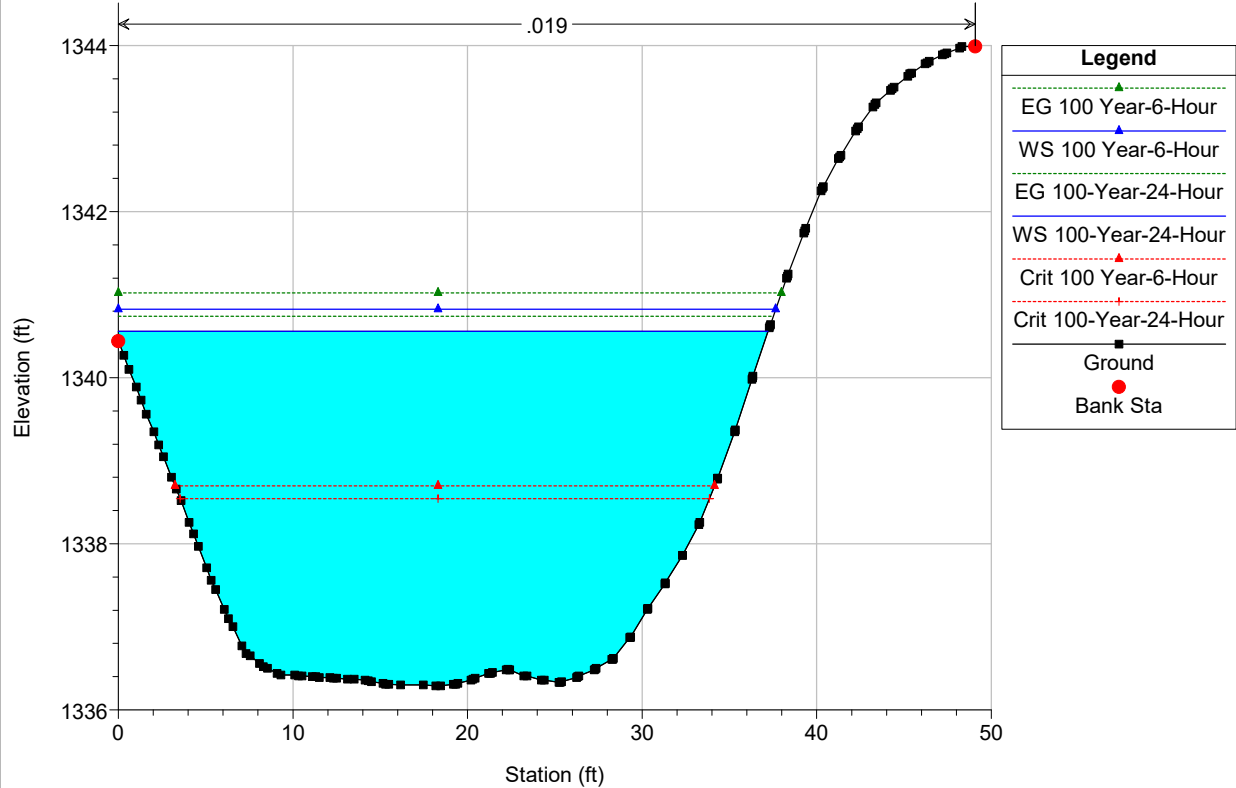
The n-value of 0.019 is not mentioned in the report. Where did it come from? Also, all bank stations are at the limits of the cross sections, please revise in final plans. (typ for all HEC-RAS)



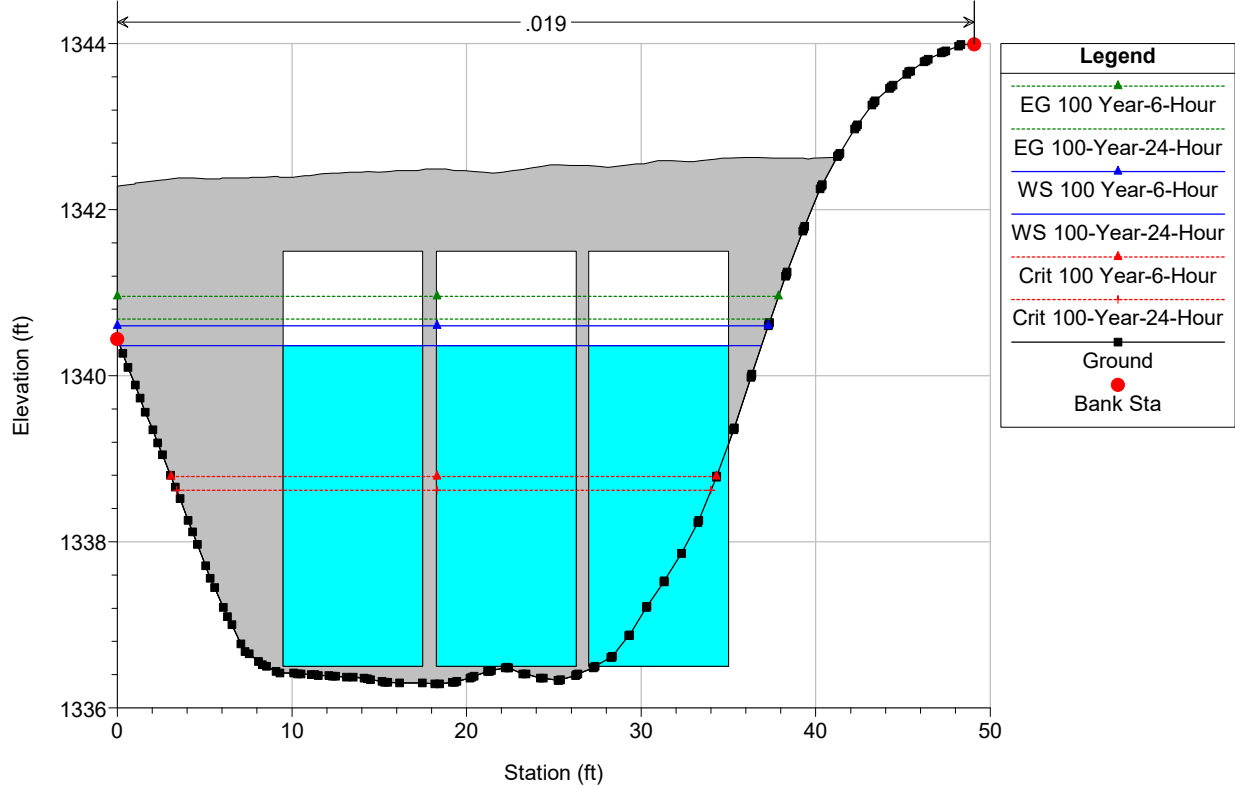
Gold Dust Aprt Plan: Gold Dust Aprt Pre-Project 2/2/2023
 River = Unnamed Wash Reach = Gold Dust Aprt. RS = 1753



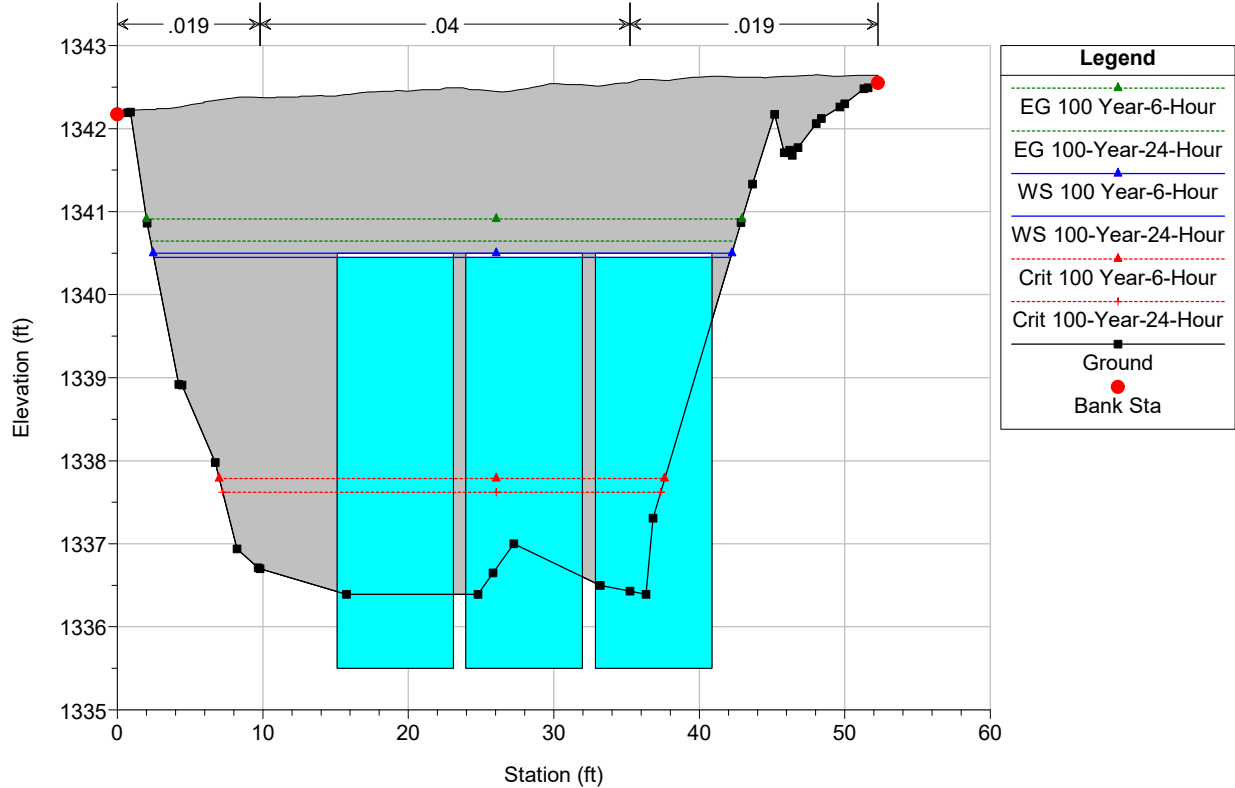
Gold Dust Aprt Plan: Gold Dust Aprt Pre-Project 2/2/2023
 River = Unnamed Wash Reach = Gold Dust Aprt. RS = 1682



Gold Dust Aprt Plan: Gold Dust Aprt Pre-Project 2/2/2023
 River = Unnamed Wash Reach = Gold Dust Aprt. RS = 1628 Culv Gold Dust Avenue

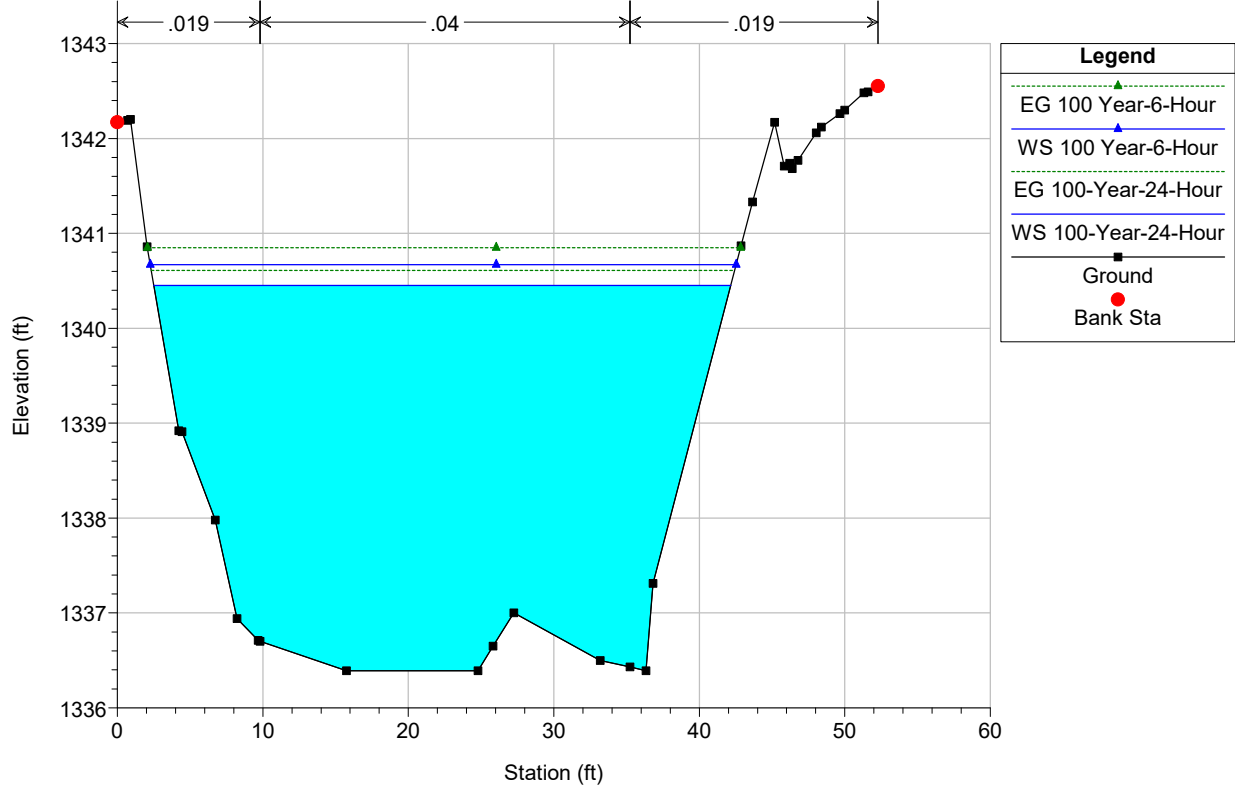


Gold Dust Aprt Plan: Gold Dust Aprt Pre-Project 2/2/2023
 River = Unnamed Wash Reach = Gold Dust Aprt. RS = 1628 Culv Gold Dust Avenue



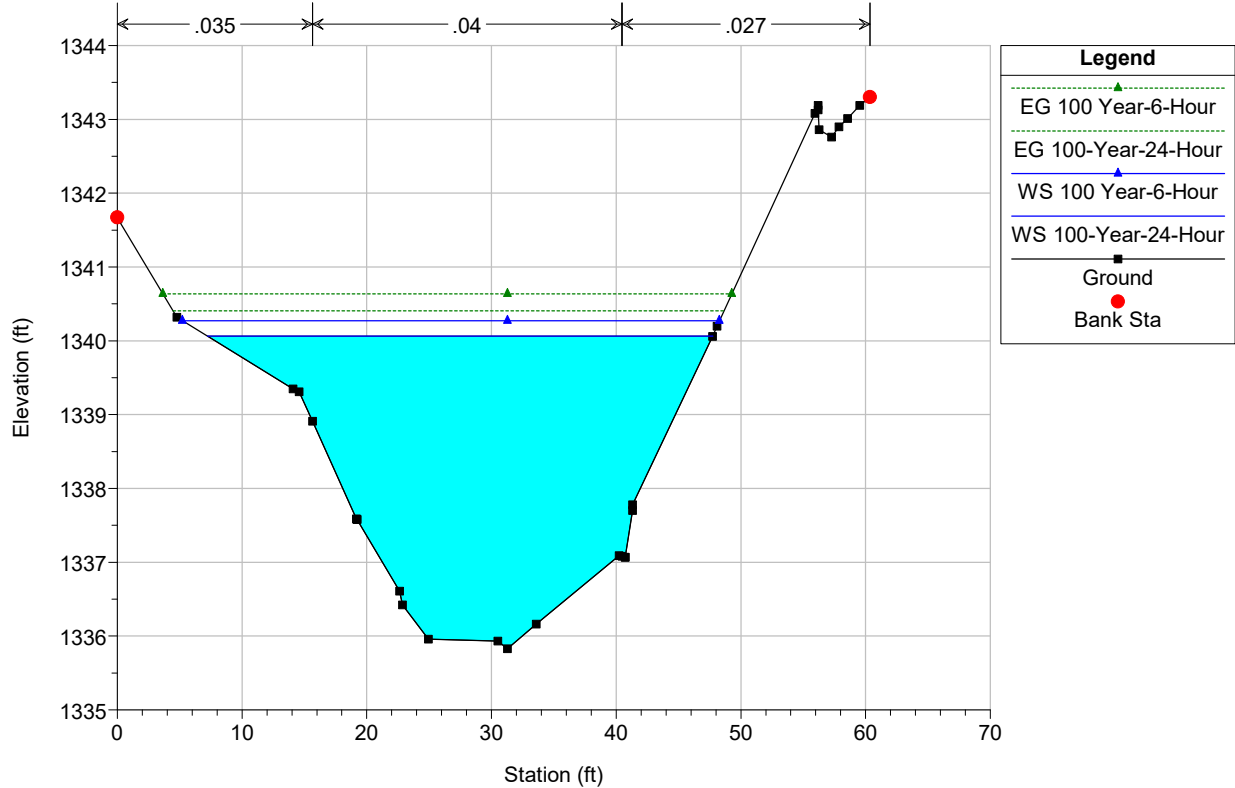
Gold Dust Aprt Plan: Gold Dust Aprt Pre-Project 2/2/2023

River = Unnamed Wash Reach = Gold Dust Aprt. RS = 1572

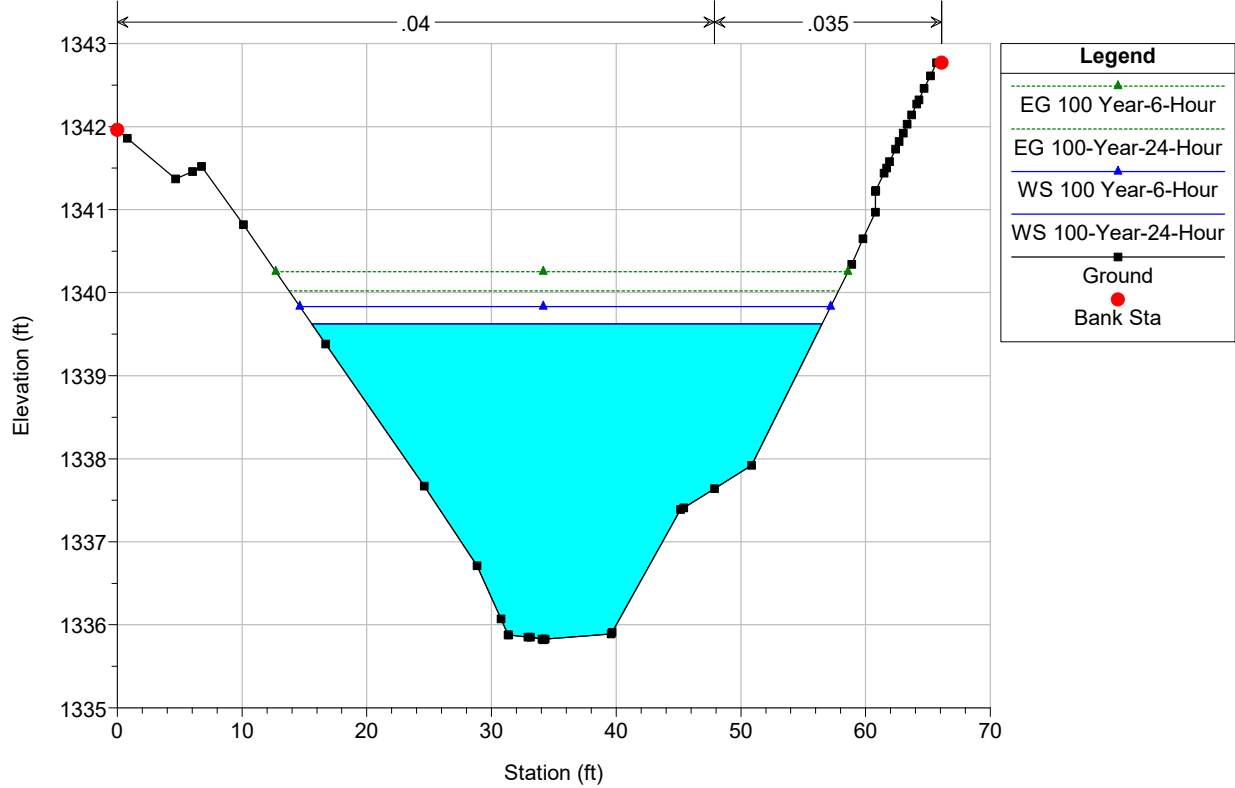


Gold Dust Aprt Plan: Gold Dust Aprt Pre-Project 2/2/2023

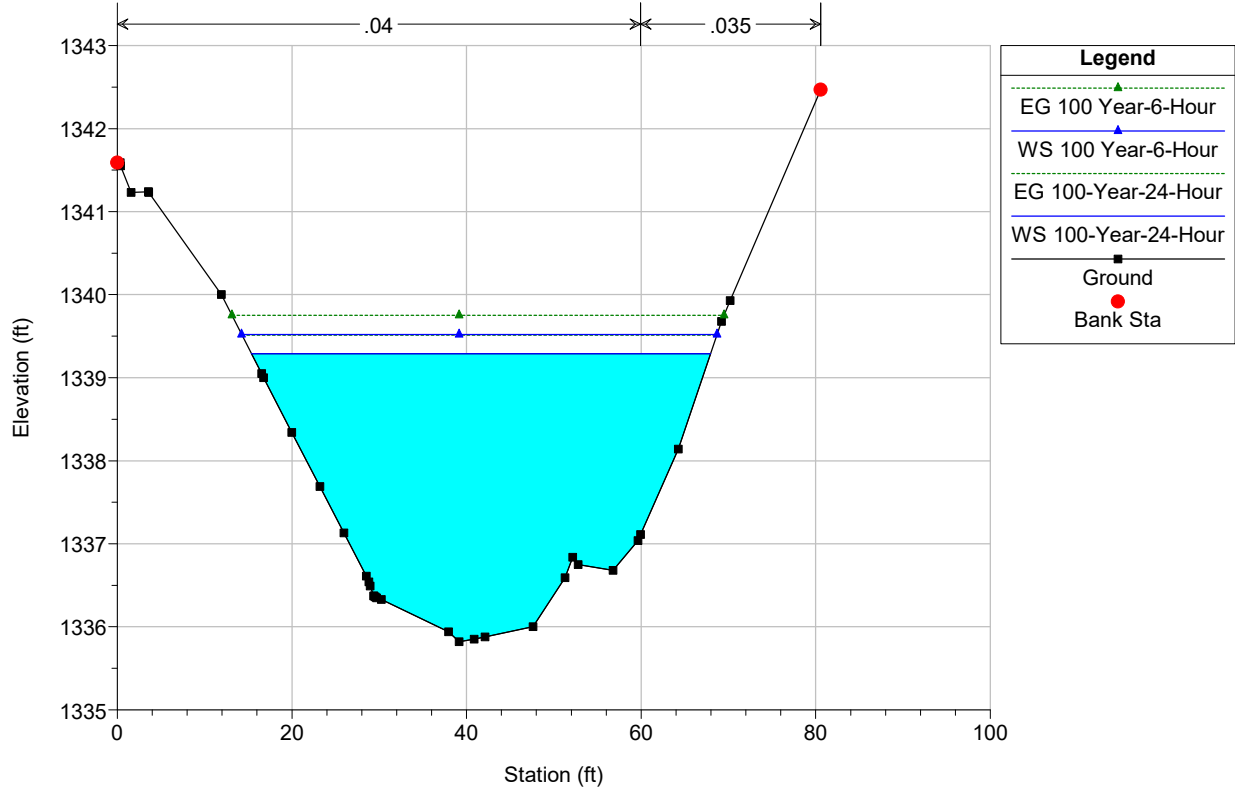
River = Unnamed Wash Reach = Gold Dust Aprt. RS = 1496



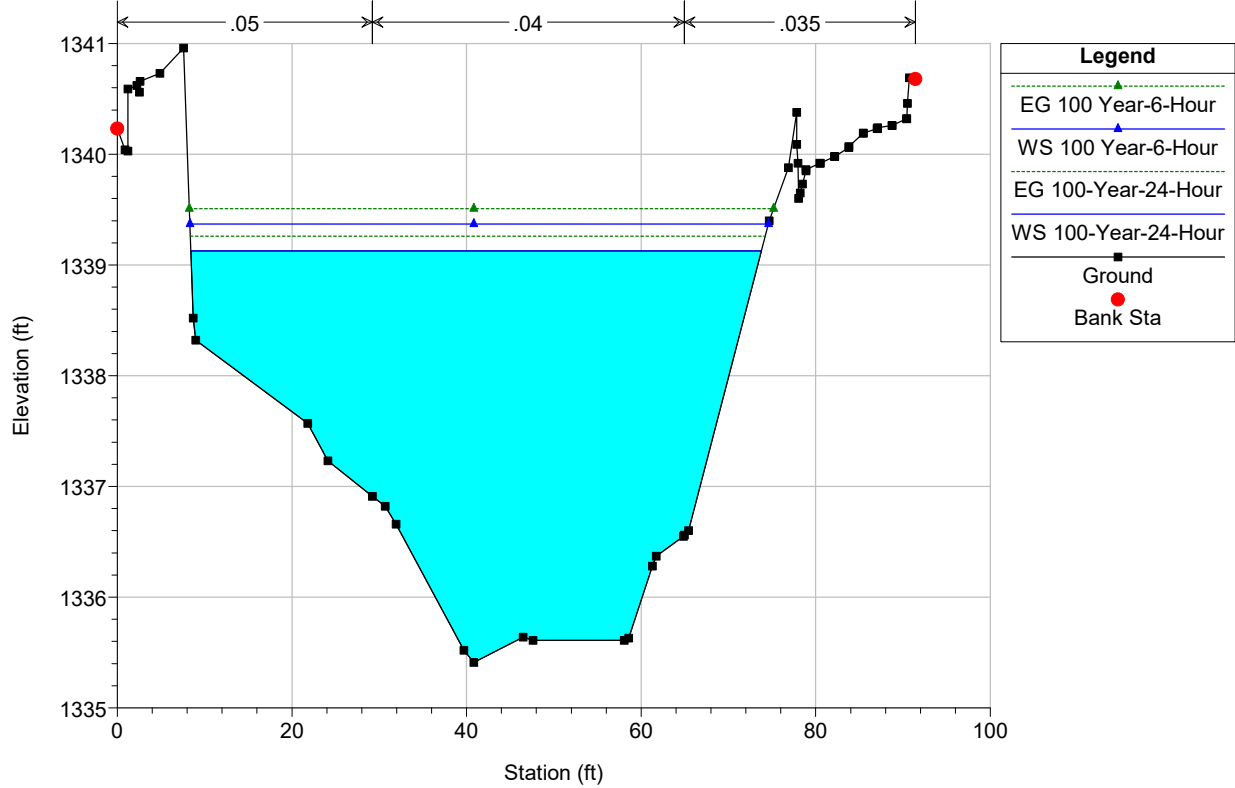
Gold Dust Aprt Plan: Gold Dust Aprt Pre-Project 2/2/2023
 River = Unnamed Wash Reach = Gold Dust Aprt. RS = 1422



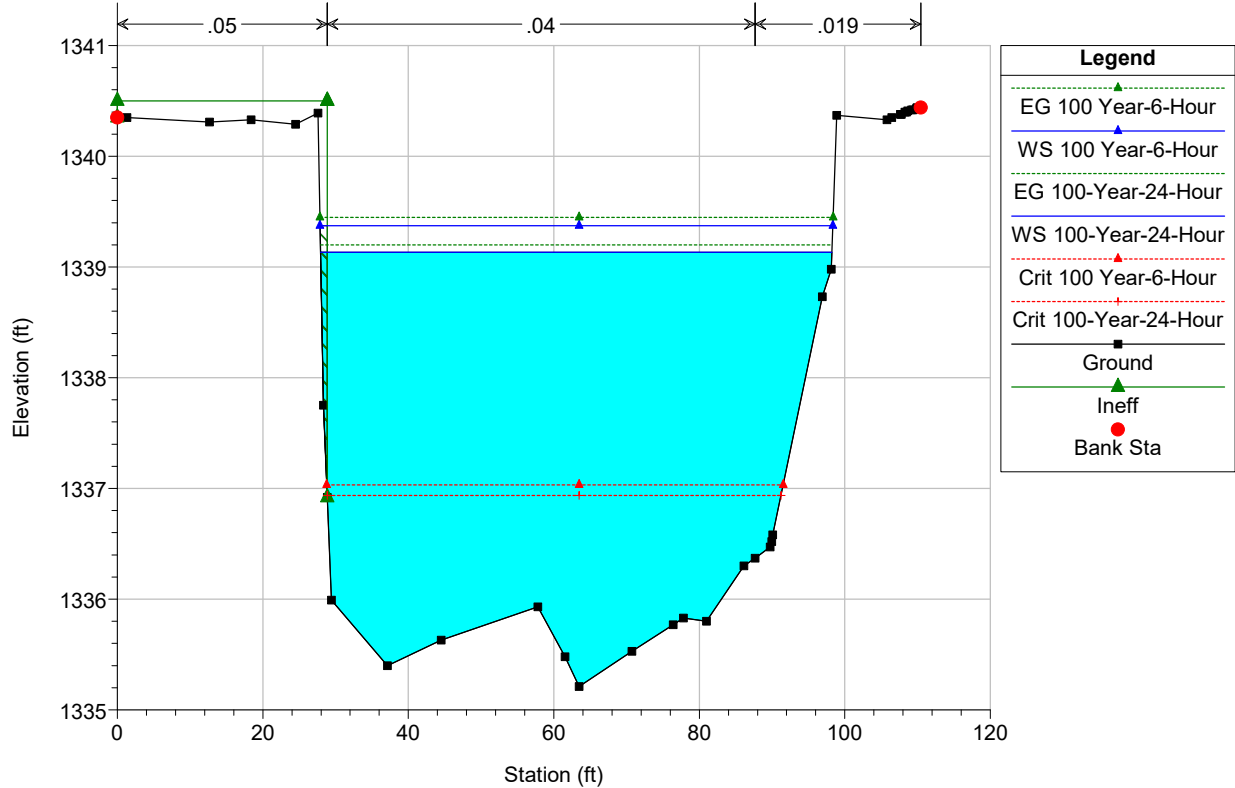
Gold Dust Aprt Plan: Gold Dust Aprt Pre-Project 2/2/2023
 River = Unnamed Wash Reach = Gold Dust Aprt. RS = 1319



Gold Dust Aprt Plan: Gold Dust Aprt Pre-Project 2/2/2023
 River = Unnamed Wash Reach = Gold Dust Aprt. RS = 1223

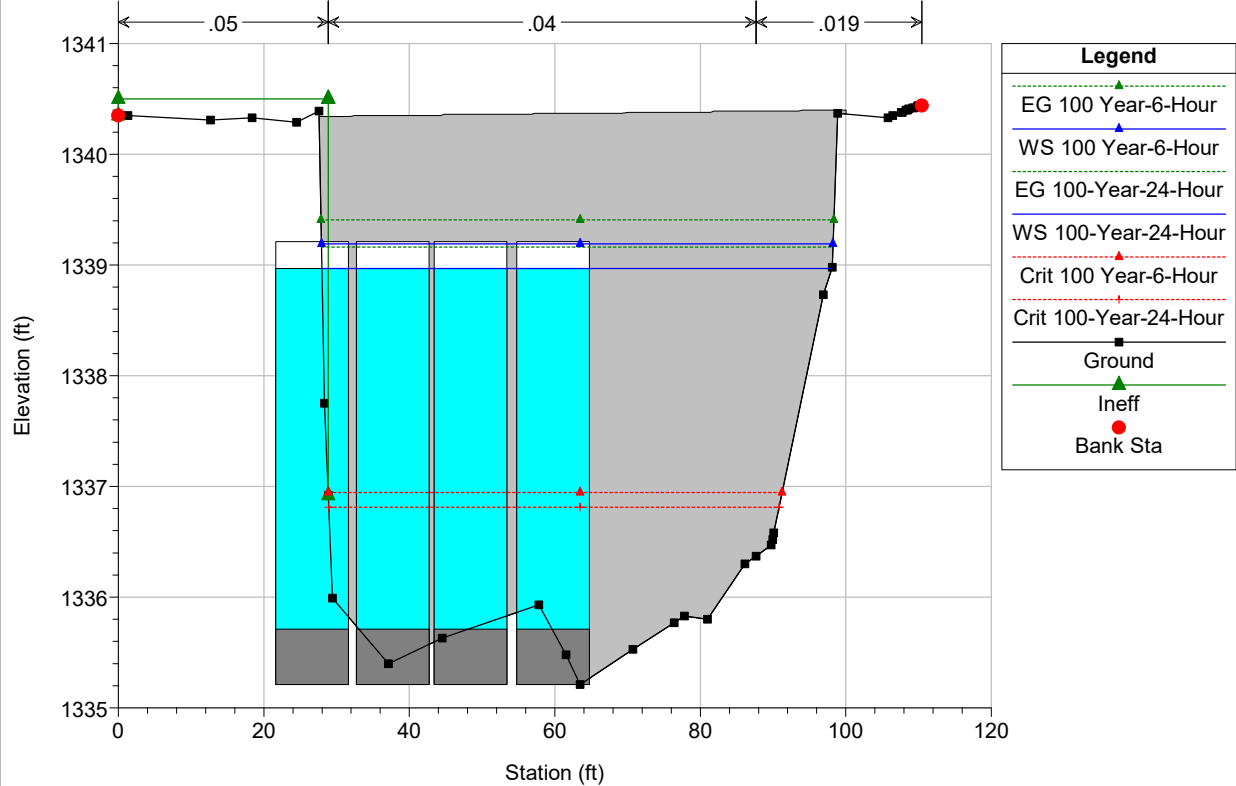


Gold Dust Aprt Plan: Gold Dust Aprt Pre-Project 2/2/2023
 River = Unnamed Wash Reach = Gold Dust Aprt. RS = 1193



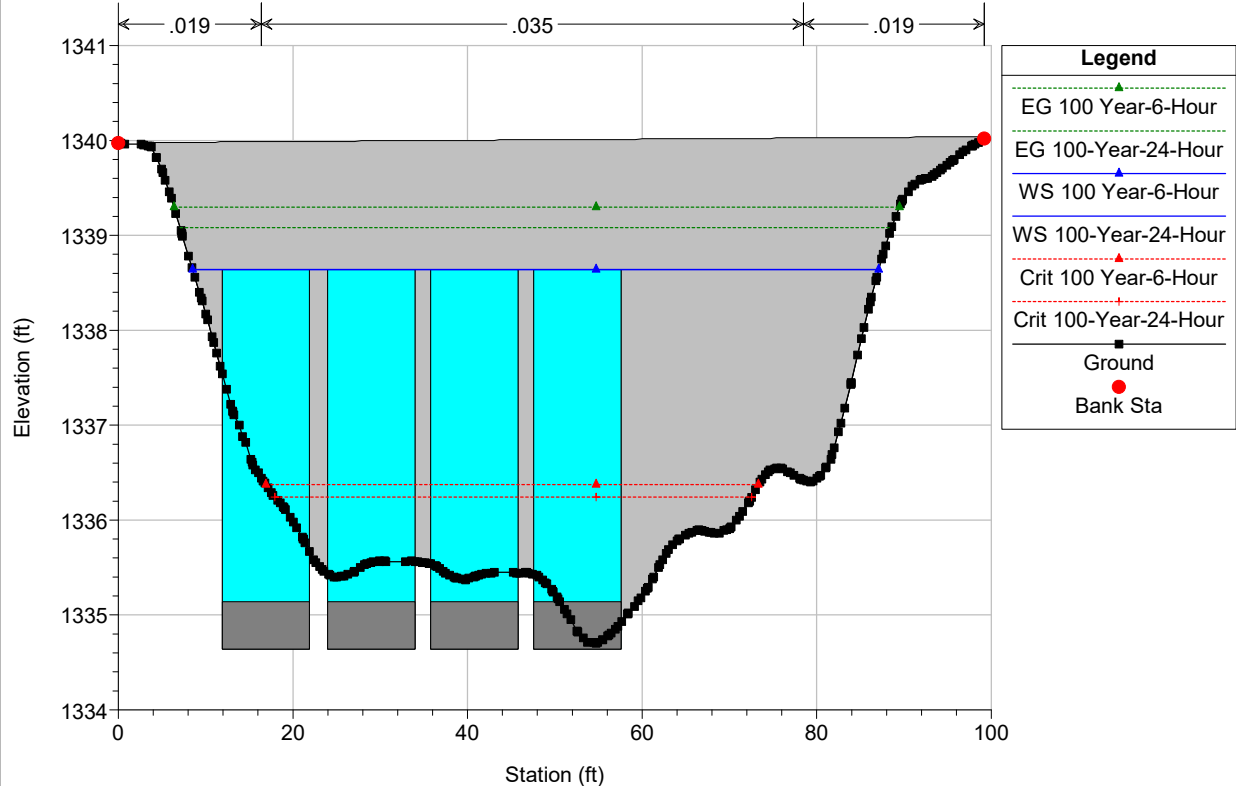
Gold Dust Aprt Plan: Gold Dust Aprt Pre-Project 2/2/2023

River = Unnamed Wash Reach = Gold Dust Aprt. RS = 1154 Culv Private Driveway

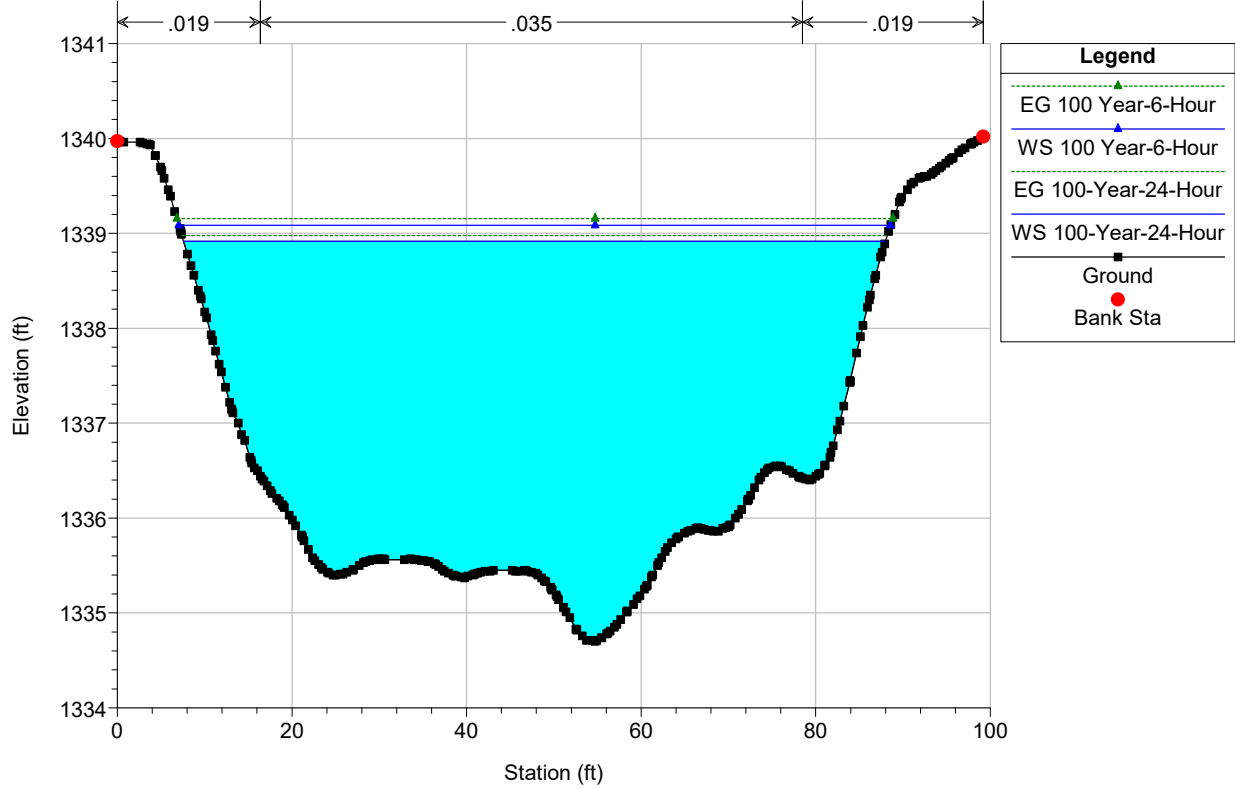


Gold Dust Aprt Plan: Gold Dust Aprt Pre-Project 2/2/2023

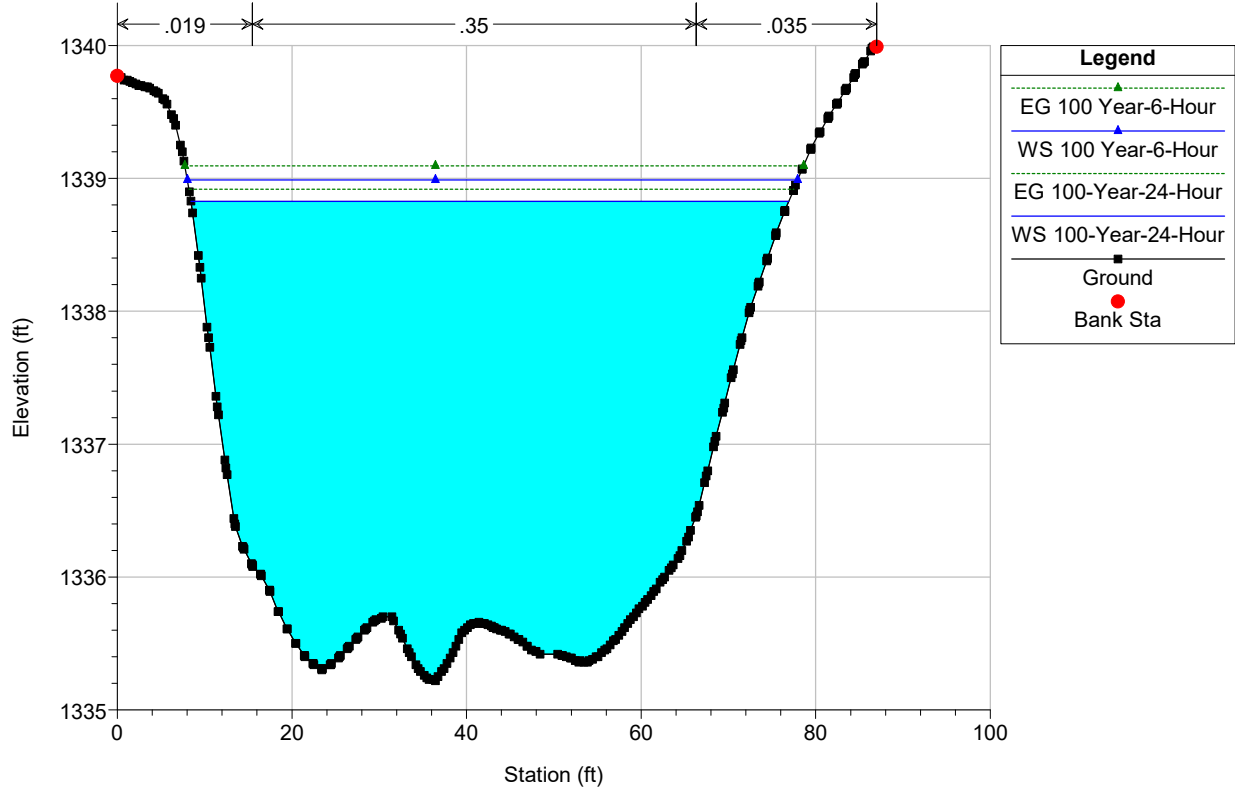
River = Unnamed Wash Reach = Gold Dust Aprt. RS = 1154 Culv Private Driveway



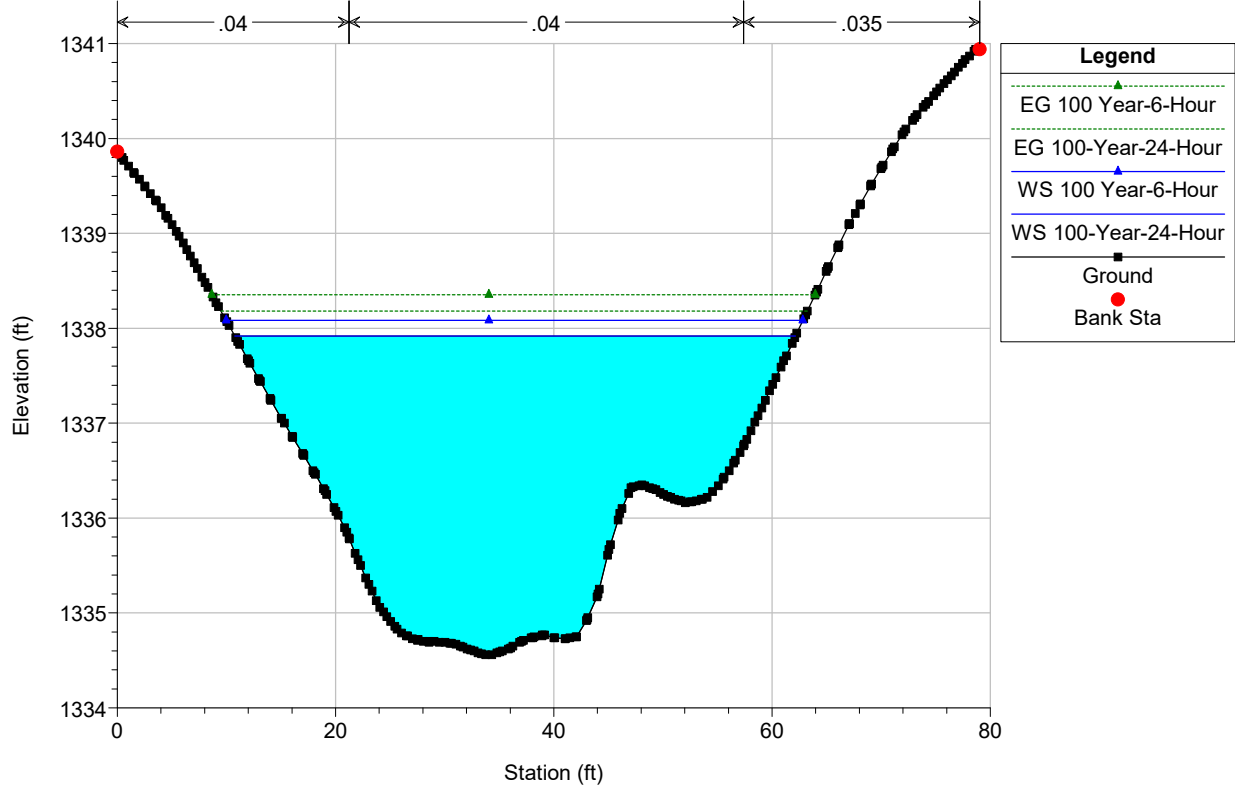
Gold Dust Aprt Plan: Gold Dust Aprt Pre-Project 2/2/2023
 River = Unnamed Wash Reach = Gold Dust Aprt. RS = 1118



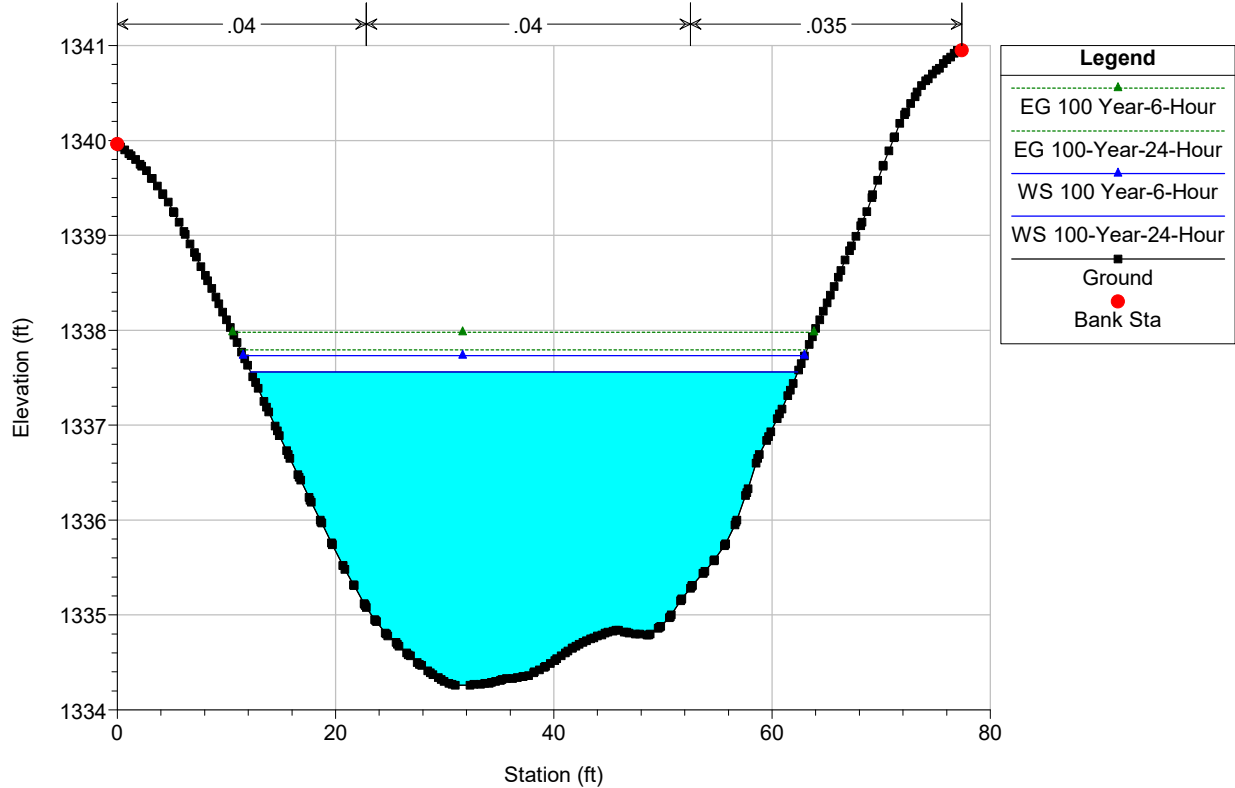
Gold Dust Aprt Plan: Gold Dust Aprt Pre-Project 2/2/2023
 River = Unnamed Wash Reach = Gold Dust Aprt. RS = 1087



Gold Dust Aprt Plan: Gold Dust Aprt Pre-Project 2/2/2023
 River = Unnamed Wash Reach = Gold Dust Aprt. RS = 1016

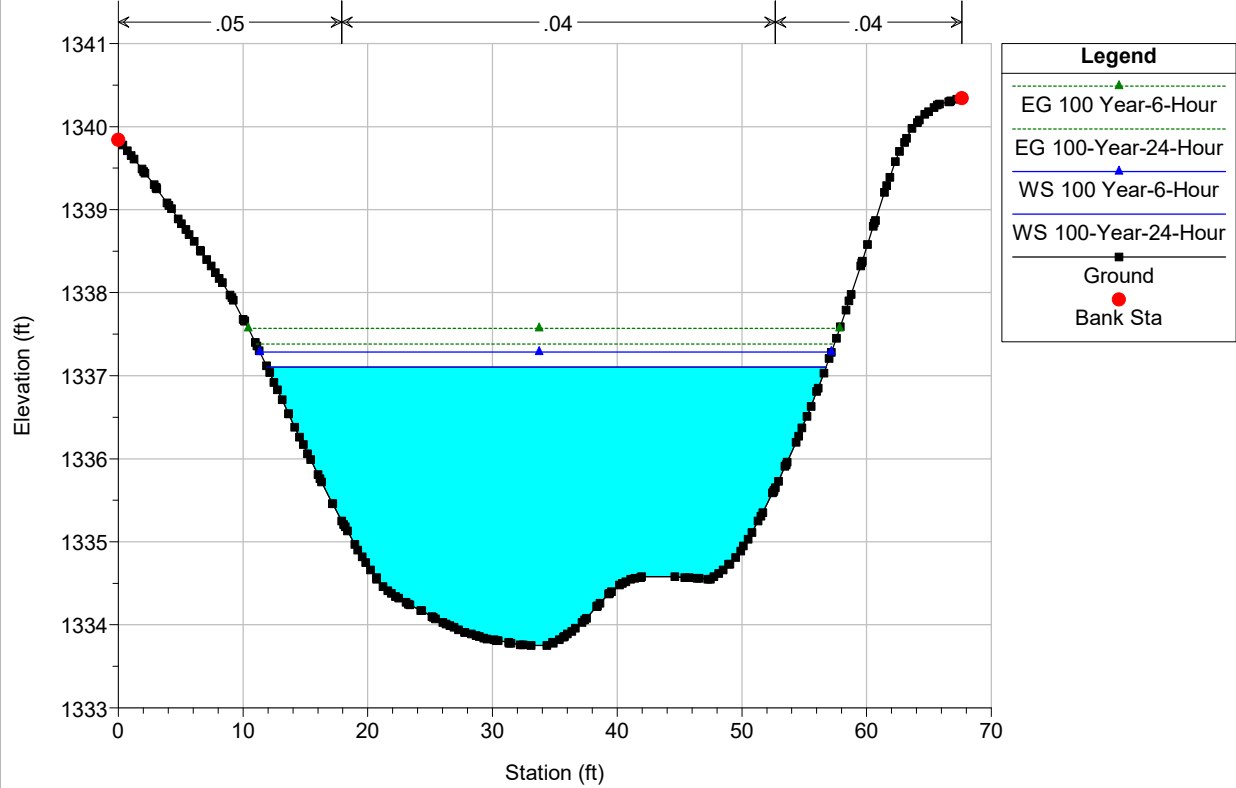


Gold Dust Aprt Plan: Gold Dust Aprt Pre-Project 2/2/2023
 River = Unnamed Wash Reach = Gold Dust Aprt. RS = 915



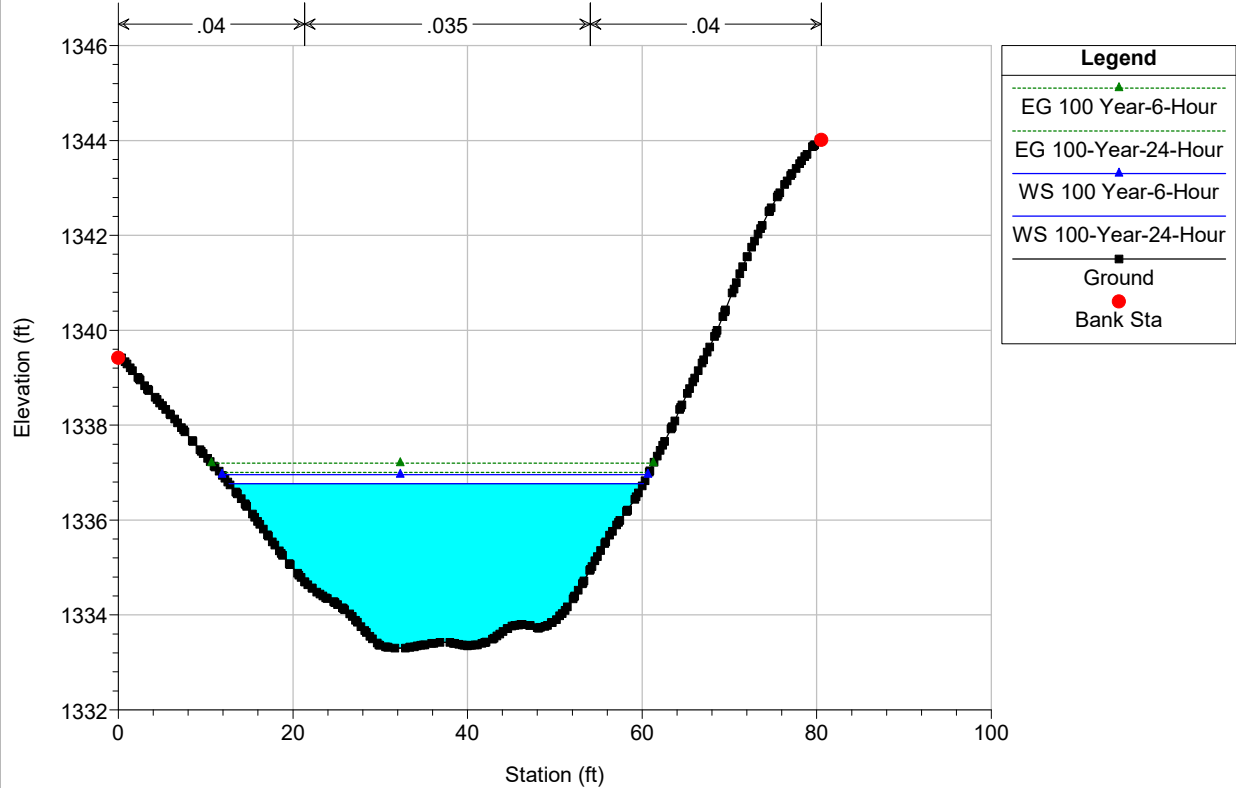
Gold Dust Aprt Plan: Gold Dust Aprt Pre-Project 2/2/2023

River = Unnamed Wash Reach = Gold Dust Aprt. RS = 812



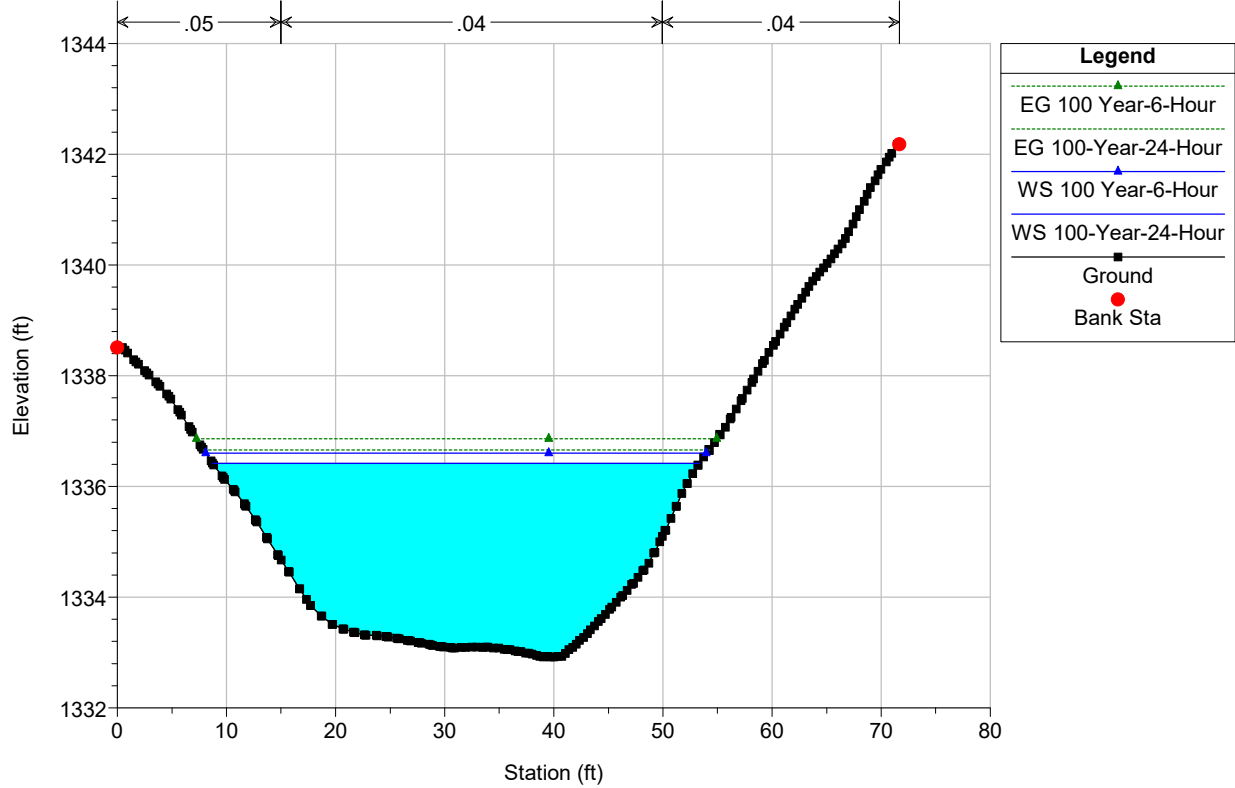
Gold Dust Aprt Plan: Gold Dust Aprt Pre-Project 2/2/2023

River = Unnamed Wash Reach = Gold Dust Aprt. RS = 712



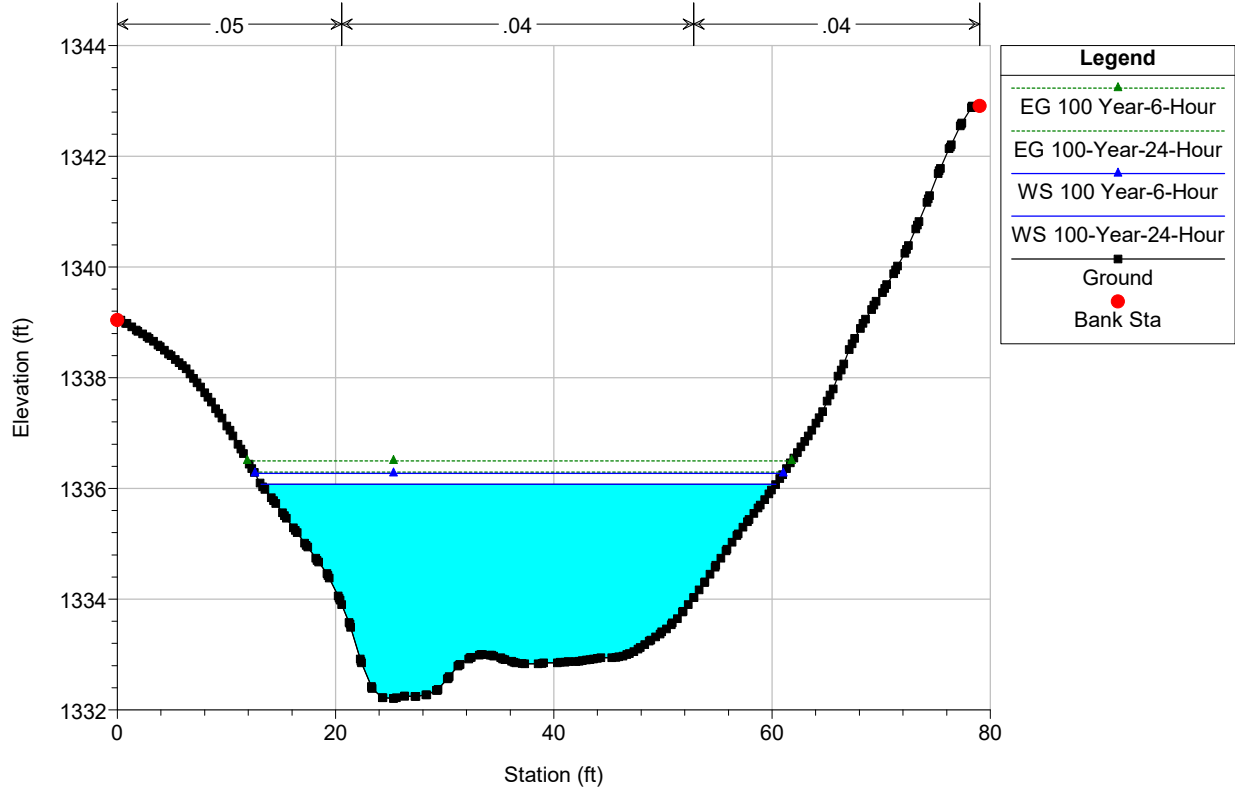
Gold Dust Aprt Plan: Gold Dust Aprt Pre-Project 2/2/2023

River = Unnamed Wash Reach = Gold Dust Aprt. RS = 609

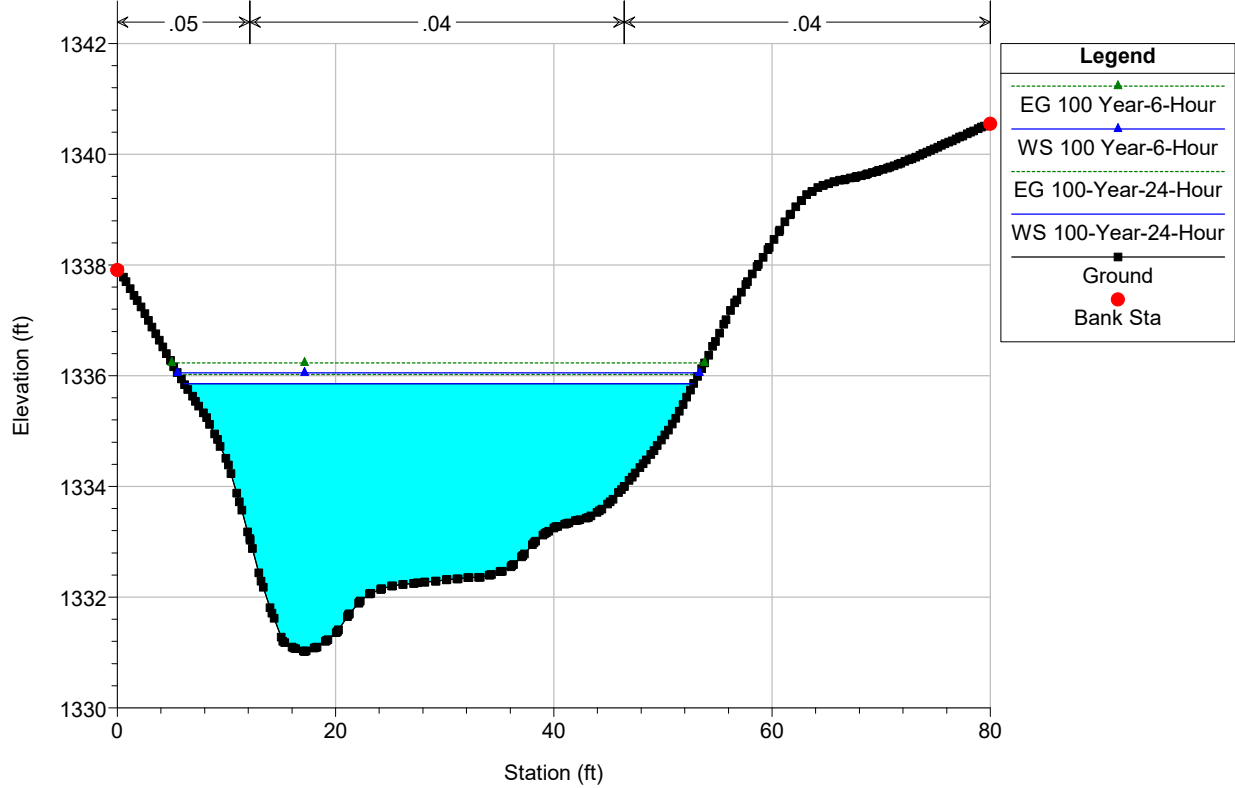


Gold Dust Aprt Plan: Gold Dust Aprt Pre-Project 2/2/2023

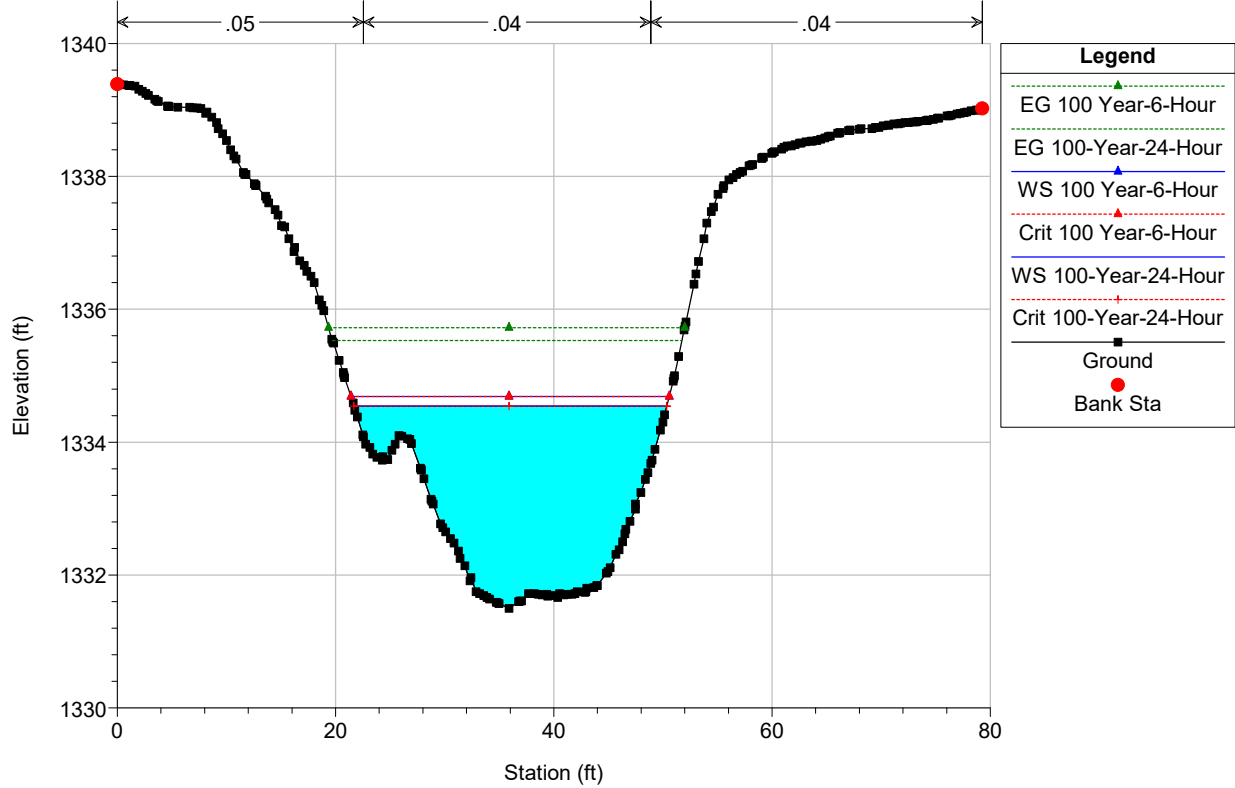
River = Unnamed Wash Reach = Gold Dust Aprt. RS = 508

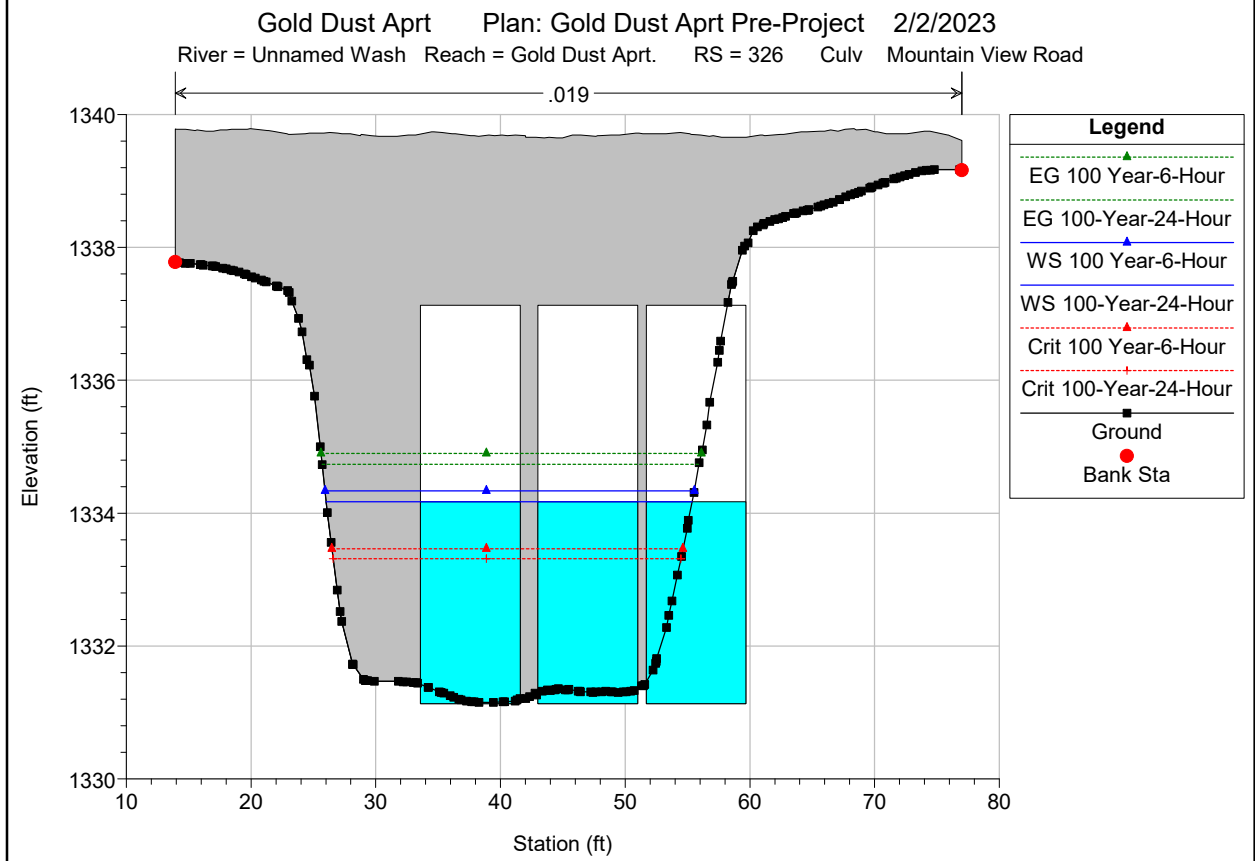
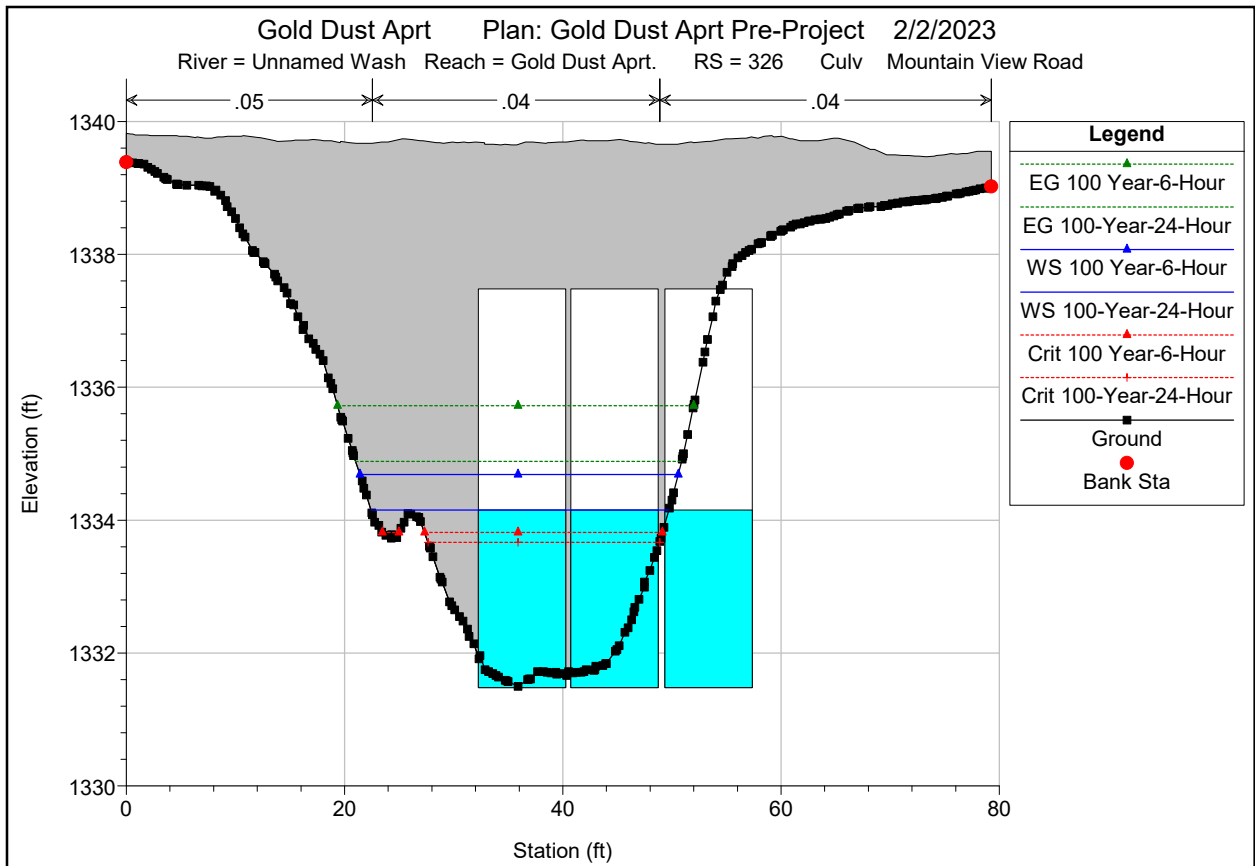


Gold Dust Aprt Plan: Gold Dust Aprt Pre-Project 2/2/2023
 River = Unnamed Wash Reach = Gold Dust Aprt. RS = 413

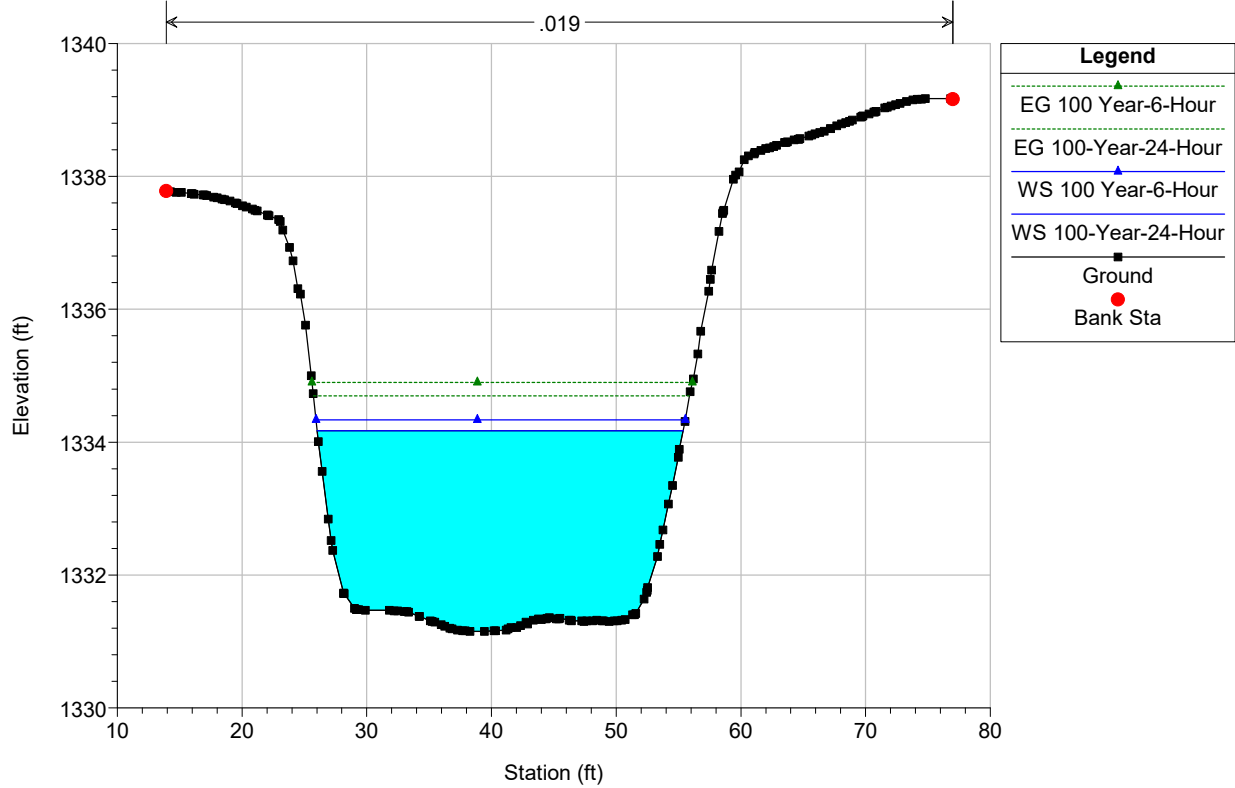


Gold Dust Aprt Plan: Gold Dust Aprt Pre-Project 2/2/2023
 River = Unnamed Wash Reach = Gold Dust Aprt. RS = 363

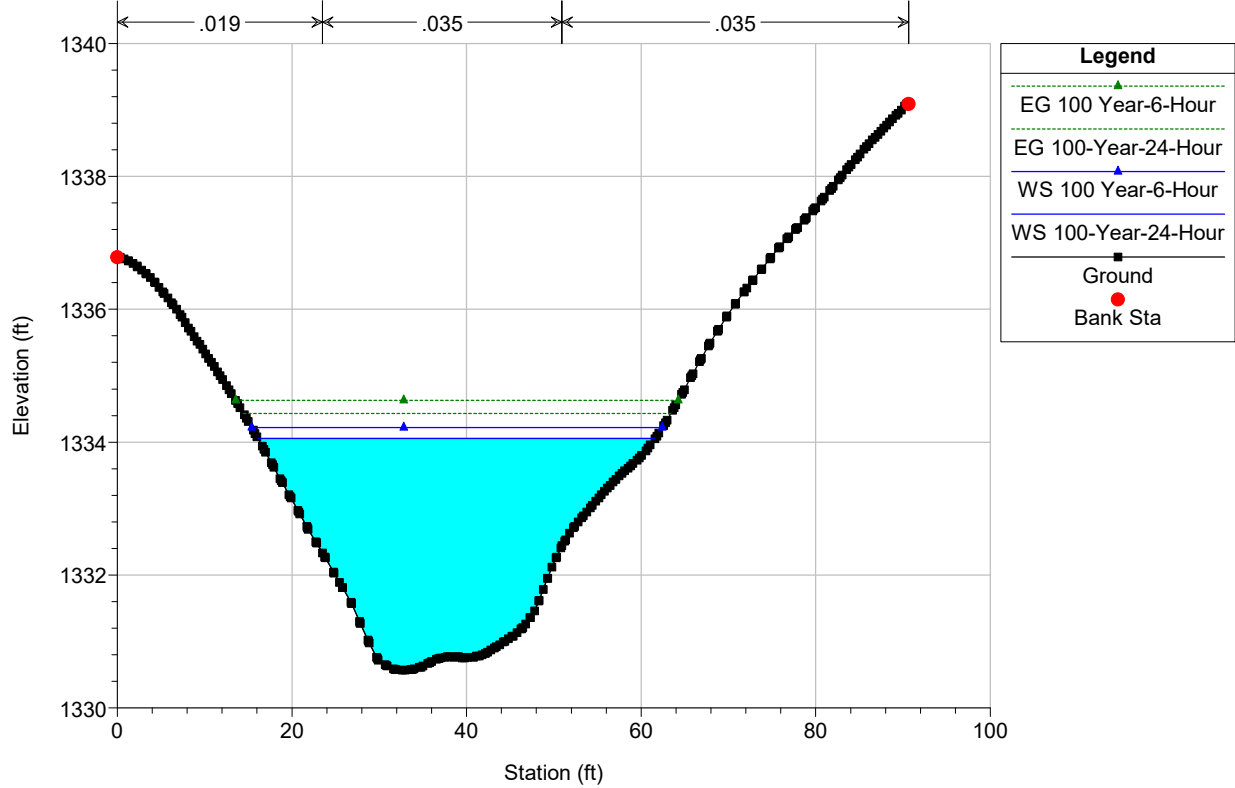




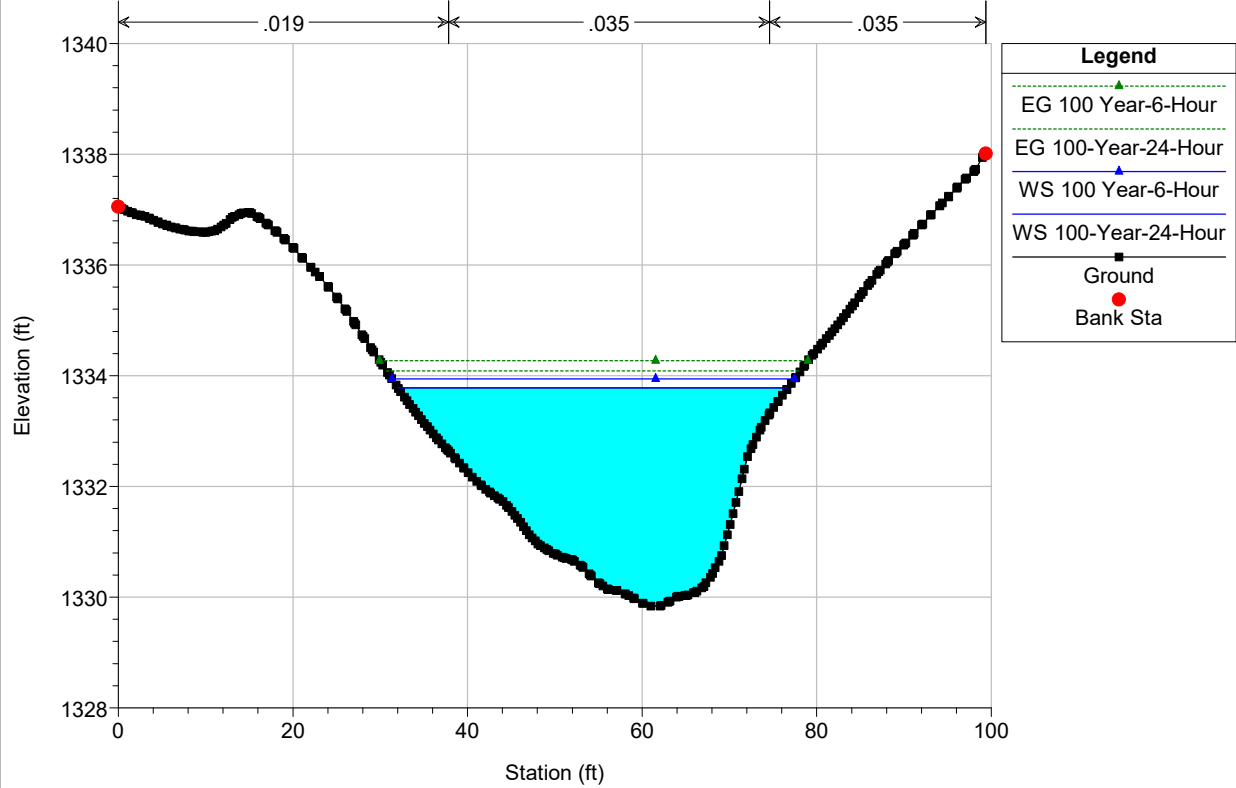
Gold Dust Aprt Plan: Gold Dust Aprt Pre-Project 2/2/2023
 River = Unnamed Wash Reach = Gold Dust Aprt. RS = 280



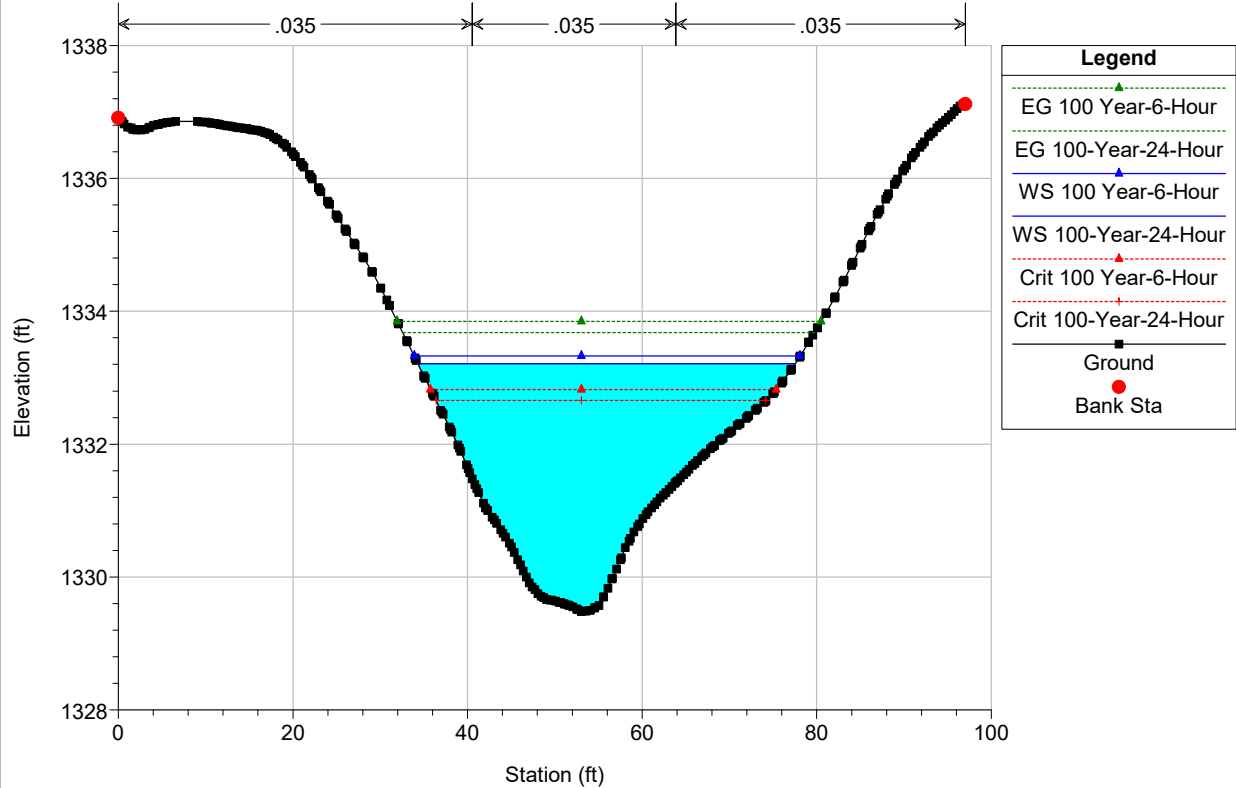
Gold Dust Aprt Plan: Gold Dust Aprt Pre-Project 2/2/2023
 River = Unnamed Wash Reach = Gold Dust Aprt. RS = 202

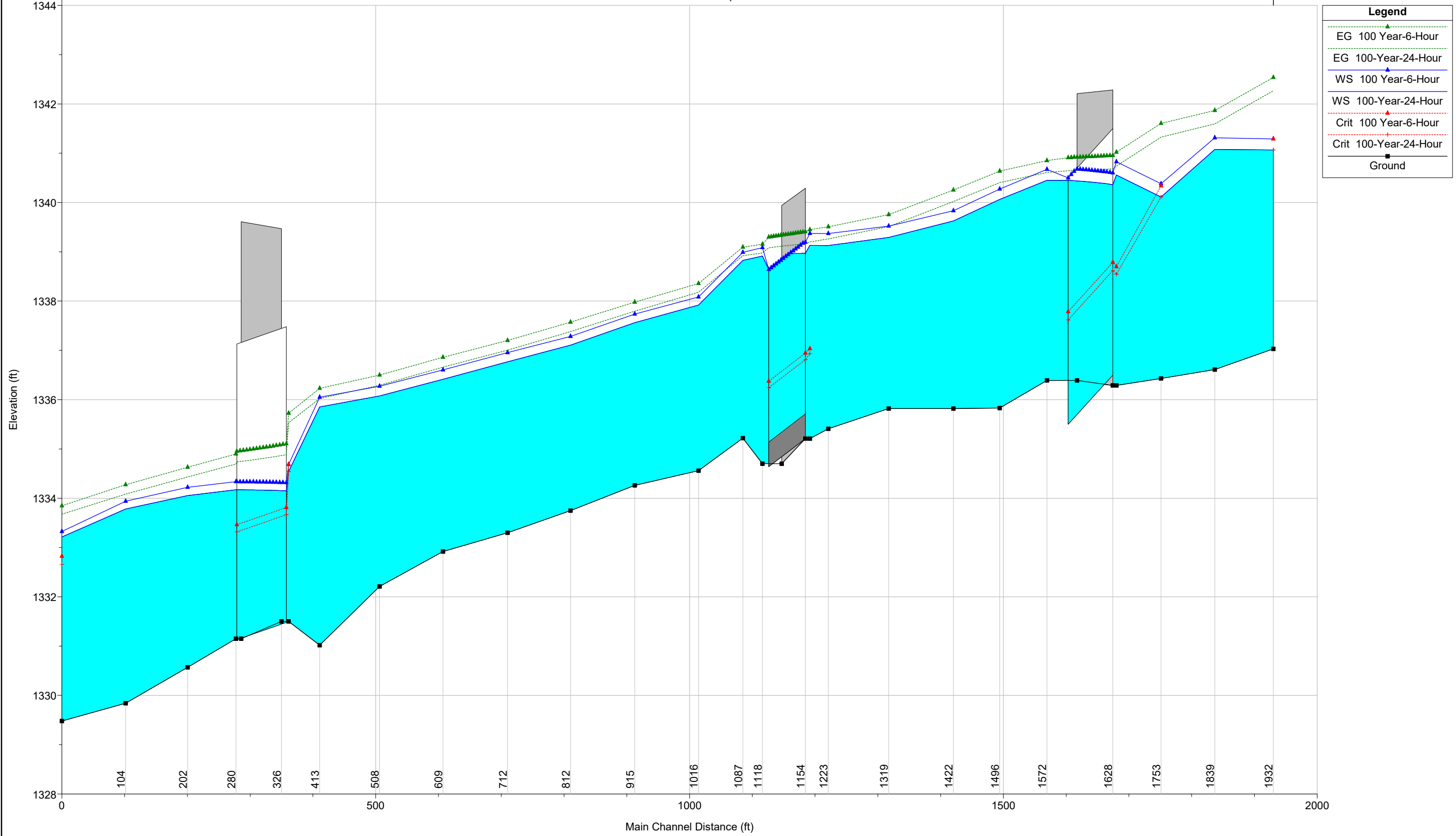


Gold Dust Aprt Plan: Gold Dust Aprt Pre-Project 2/2/2023
 River = Unnamed Wash Reach = Gold Dust Aprt. RS = 104



Gold Dust Aprt Plan: Gold Dust Aprt Pre-Project 2/2/2023
 River = Unnamed Wash Reach = Gold Dust Aprt. RS = 2





HEC-RAS Plan: Gold Dust Aprt Pre-Project River: Unnamed Wash Reach: Gold Dust Aprt.

Reach	River Sta	Profile	Q Total (cfs)	Min Ch El (ft)	W.S. Elev (ft)	Crit W.S. (ft)	E.G. Elev (ft)	E.G. Slope (ft/ft)	Vel Chnl (ft/s)	Flow Area (sq ft)	Top Width (ft)	Froude # Chl
Gold Dust Aprt.	1932	100-Year-24-Hour	420.00	1337.03	1341.07	1341.07	1342.27	0.004486	8.79	47.79	20.25	1.01
Gold Dust Aprt.	1932	100 Year-6-Hour	470.00	1337.03	1341.29	1341.29	1342.54	0.004414	8.96	52.43	21.30	1.01
Gold Dust Aprt.	1839	100-Year-24-Hour	420.00	1336.61	1341.08		1341.60	0.001441	5.78	72.72	24.75	0.59
Gold Dust Aprt.	1839	100 Year-6-Hour	470.00	1336.61	1341.31		1341.87	0.001461	5.98	78.61	25.63	0.60
Gold Dust Aprt.	1753	100-Year-24-Hour	420.00	1336.43	1340.11	1340.11	1341.33	0.004446	8.83	47.54	19.89	1.01
Gold Dust Aprt.	1753	100 Year-6-Hour	470.00	1336.43	1340.38	1340.34	1341.60	0.004138	8.87	52.98	20.81	0.98
Gold Dust Aprt.	1682	100-Year-24-Hour	420.00	1336.29	1340.56	1338.54	1340.74	0.000414	3.41	123.08	37.21	0.33
Gold Dust Aprt.	1682	100 Year-6-Hour	470.00	1336.29	1340.83	1338.70	1341.02	0.000410	3.53	133.11	37.66	0.33
Gold Dust Aprt.	1628											
Gold Dust Aprt.	1572	100-Year-24-Hour	420.00	1336.39	1340.45		1340.61	0.001112	3.22	130.24	39.64	0.31
Gold Dust Aprt.	1572	100 Year-6-Hour	470.00	1336.39	1340.67		1340.85	0.001130	3.38	139.13	40.27	0.32
Gold Dust Aprt.	1496	100-Year-24-Hour	460.00	1335.83	1340.06		1340.41	0.004318	4.69	98.09	40.52	0.53
Gold Dust Aprt.	1496	100 Year-6-Hour	518.00	1335.83	1340.27		1340.64	0.004417	4.85	106.82	43.06	0.54
Gold Dust Aprt.	1422	100-Year-24-Hour	460.00	1335.82	1339.63		1340.02	0.006192	5.04	91.20	40.93	0.60
Gold Dust Aprt.	1422	100 Year-6-Hour	518.00	1335.82	1339.83		1340.25	0.006099	5.19	99.90	42.57	0.60
Gold Dust Aprt.	1319	100-Year-24-Hour	460.00	1335.82	1339.29		1339.51	0.003315	3.78	121.72	52.60	0.44
Gold Dust Aprt.	1319	100 Year-6-Hour	518.00	1335.82	1339.52		1339.75	0.003190	3.87	134.02	54.45	0.43
Gold Dust Aprt.	1223	100-Year-24-Hour	460.00	1335.41	1339.13		1339.26	0.001740	2.93	157.03	65.35	0.33
Gold Dust Aprt.	1223	100 Year-6-Hour	518.00	1335.41	1339.37		1339.51	0.001666	3.00	172.95	66.26	0.33
Gold Dust Aprt.	1193	100-Year-24-Hour	460.00	1335.21	1339.13	1336.94	1339.20	0.000605	2.10	218.78	70.27	0.21
Gold Dust Aprt.	1193	100 Year-6-Hour	518.00	1335.21	1339.37	1337.03	1339.45	0.000598	2.20	235.62	70.48	0.21
Gold Dust Aprt.	1154											
Gold Dust Aprt.	1118	100-Year-24-Hour	460.00	1334.70	1338.92		1338.98	0.000436	1.98	232.89	80.40	0.20
Gold Dust Aprt.	1118	100 Year-6-Hour	518.00	1334.70	1339.09		1339.15	0.000460	2.10	246.73	81.52	0.21
Gold Dust Aprt.	1087	100-Year-24-Hour	460.00	1335.22	1338.83		1338.92	0.059473	2.45	187.61	68.45	0.26
Gold Dust Aprt.	1087	100 Year-6-Hour	518.00	1335.22	1338.99		1339.09	0.062155	2.60	198.88	69.91	0.27
Gold Dust Aprt.	1016	100-Year-24-Hour	440.00	1334.56	1337.92		1338.18	0.003942	4.10	107.43	51.38	0.50
Gold Dust Aprt.	1016	100 Year-6-Hour	485.00	1334.56	1338.08		1338.35	0.003834	4.18	115.95	52.85	0.50
Gold Dust Aprt.	915	100-Year-24-Hour	440.00	1334.26	1337.56		1337.79	0.003515	3.86	113.86	50.15	0.45
Gold Dust Aprt.	915	100 Year-6-Hour	485.00	1334.26	1337.73		1337.98	0.003448	3.96	122.63	51.46	0.45
Gold Dust Aprt.	812	100-Year-24-Hour	440.00	1333.75	1337.11		1337.38	0.004566	4.21	104.58	44.83	0.49
Gold Dust Aprt.	812	100 Year-6-Hour	485.00	1333.75	1337.28		1337.57	0.004487	4.31	112.64	45.83	0.48
Gold Dust Aprt.	712	100-Year-24-Hour	440.00	1333.30	1336.77		1337.00	0.002967	3.89	112.97	47.48	0.45
Gold Dust Aprt.	712	100 Year-6-Hour	485.00	1333.30	1336.96		1337.20	0.002917	3.98	121.93	48.81	0.44
Gold Dust Aprt.	609	100-Year-24-Hour	440.00	1332.92	1336.41		1336.66	0.003776	3.98	110.68	44.60	0.44
Gold Dust Aprt.	609	100 Year-6-Hour	485.00	1332.92	1336.60		1336.86	0.003739	4.07	119.24	45.89	0.44
Gold Dust Aprt.	508	100-Year-24-Hour	440.00	1332.21	1336.08		1336.29	0.003331	3.73	117.99	47.18	0.42
Gold Dust Aprt.	508	100 Year-6-Hour	485.00	1332.21	1336.27		1336.50	0.003263	3.81	127.37	48.44	0.41
Gold Dust Aprt.	413	100-Year-24-Hour	440.00	1331.02	1335.85		1336.02	0.002207	3.31	133.11	46.67	0.35
Gold Dust Aprt.	413	100 Year-6-Hour	485.00	1331.02	1336.05		1336.23	0.002224	3.41	142.40	47.82	0.35
Gold Dust Aprt.	363	100-Year-24-Hour	440.00	1331.50	1334.54	1334.54	1335.53	0.020865	7.97	55.23	28.69	1.01
Gold Dust Aprt.	363	100 Year-6-Hour	485.00	1331.50	1334.69	1334.69	1335.72	0.020577	8.18	59.32	29.18	1.01
Gold Dust Aprt.	326											
Gold Dust Aprt.	280	100-Year-24-Hour	440.00	1331.15	1334.17		1334.70	0.001704	5.80	75.90	29.35	0.64
Gold Dust Aprt.	280	100 Year-6-Hour	485.00	1331.15	1334.34		1334.90	0.001718	6.01	80.70	29.62	0.64
Gold Dust Aprt.	202	100-Year-24-Hour	470.00	1330.57	1334.05		1334.43	0.003746	4.94	95.12	45.49	0.60
Gold Dust Aprt.	202	100 Year-6-Hour	526.00	1330.57	1334.22		1334.63	0.003769	5.12	102.82	47.04	0.61
Gold Dust Aprt.	104	100-Year-24-Hour	470.00	1329.84	1333.78		1334.08	0.002946	4.42	106.32	44.71	0.51
Gold Dust Aprt.	104	100 Year-6-Hour	526.00	1329.84	1333.94		1334.27	0.003020	4.63	113.58	46.12	0.52
Gold Dust Aprt.	2	100-Year-24-Hour	470.00	1329.48	1333.21	1332.66	1333.68	0.005215	5.47	85.96	43.24	0.68
Gold Dust Aprt.	2	100 Year-6-Hour	526.00	1329.48	1333.33	1332.82	1333.85	0.005621	5.79	90.86	44.19	0.71



Legend	
●	BANK STATION
---	RIVER REACH
	ROADWAY CROSSING
	CROSS SECTION W/ RIVER STATION
	100 YR INUNDATION

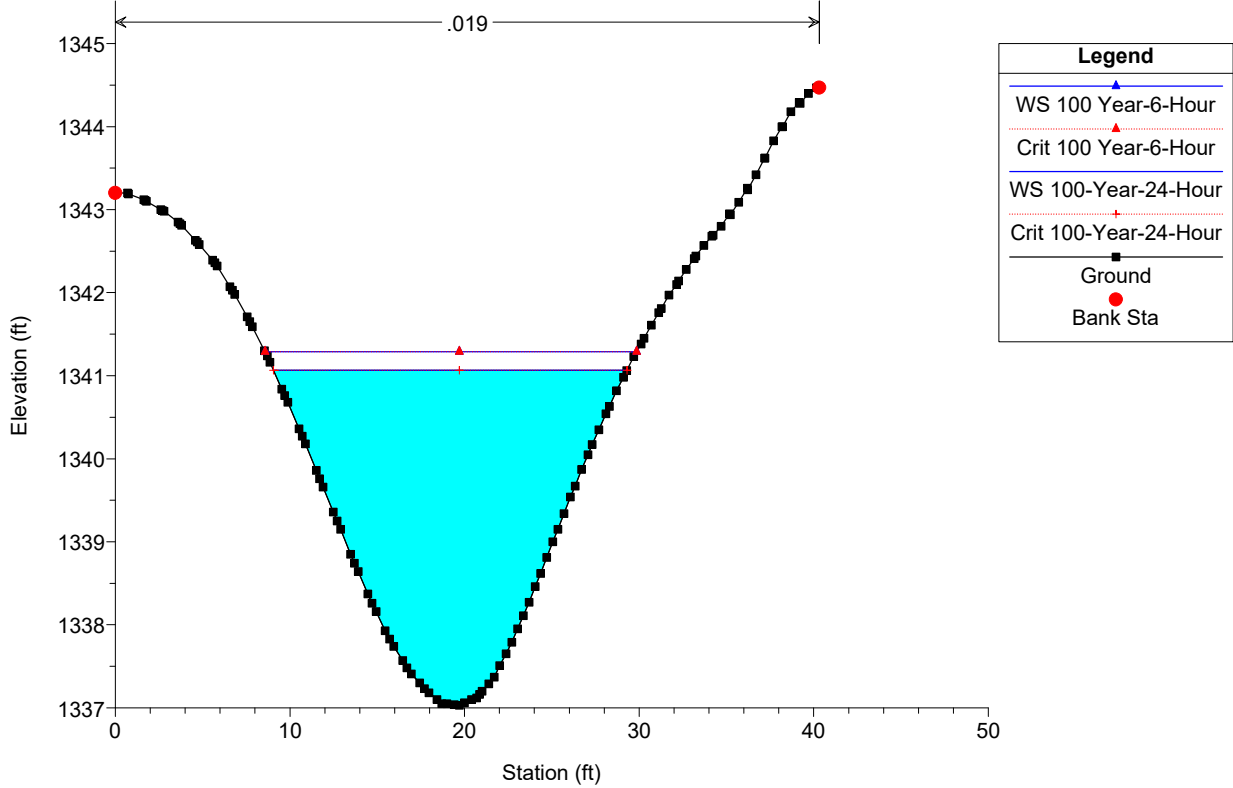
GOLD DUST APARTMENTS - UNNAMED CHANNEL

**Exhibit G-2
Post Project Condition 100 Year Inundation**

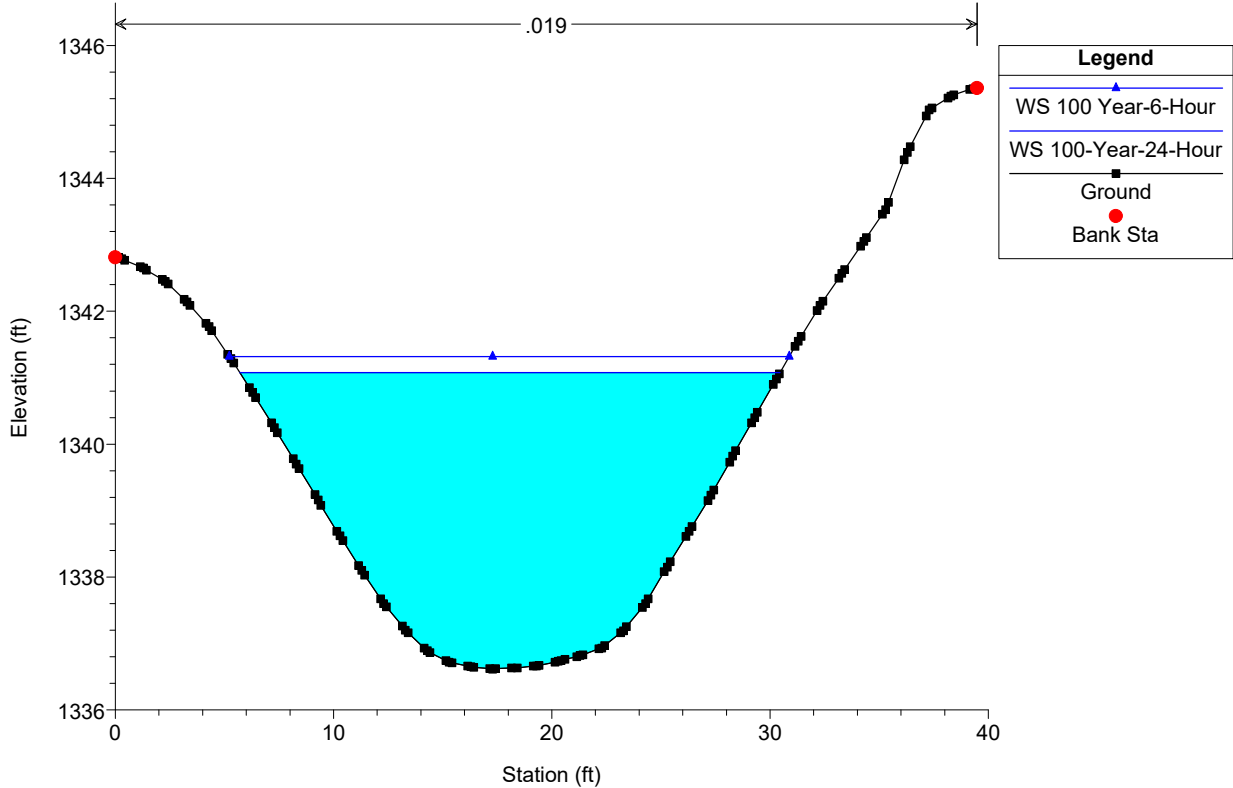


Exhibit G-1: Post Project Condition 100 Year Inundation

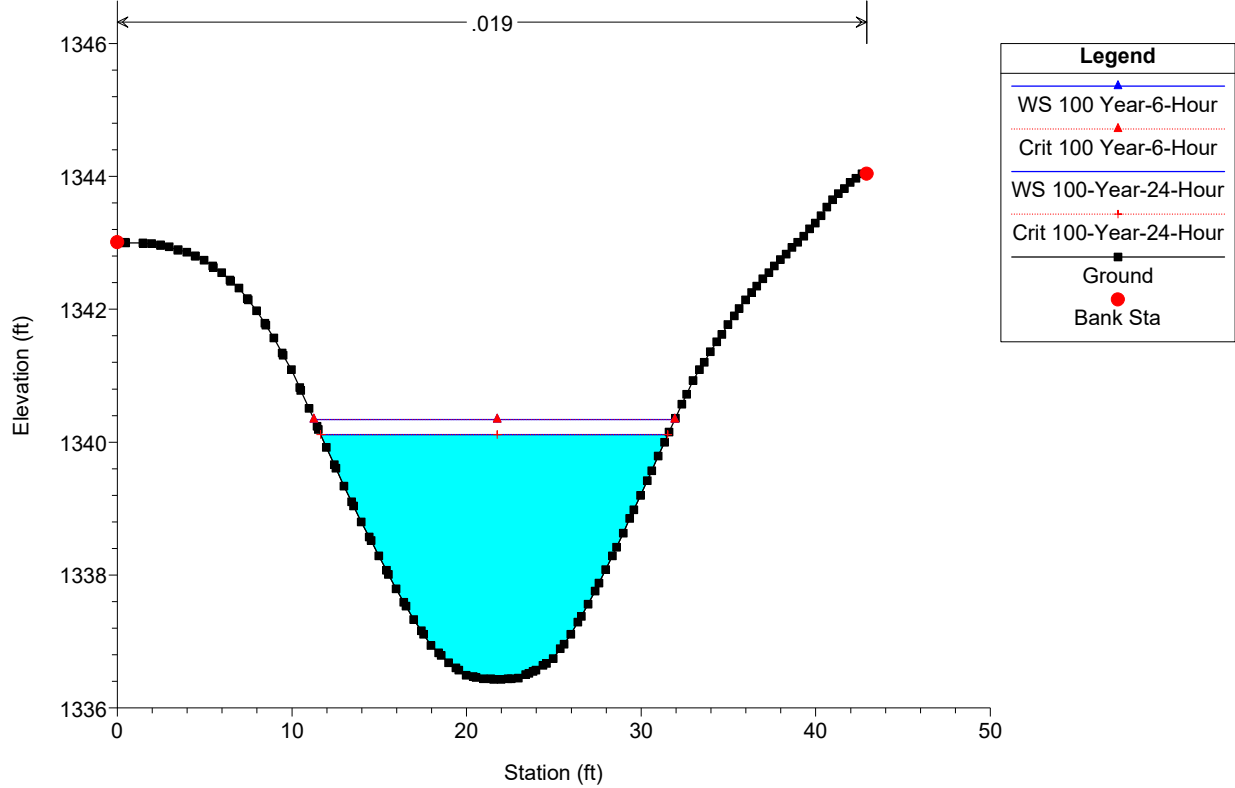
Gold Dust Aprt Plan: Gold Dust Aprt Pre-Project 9/1/2022
RS = 1932



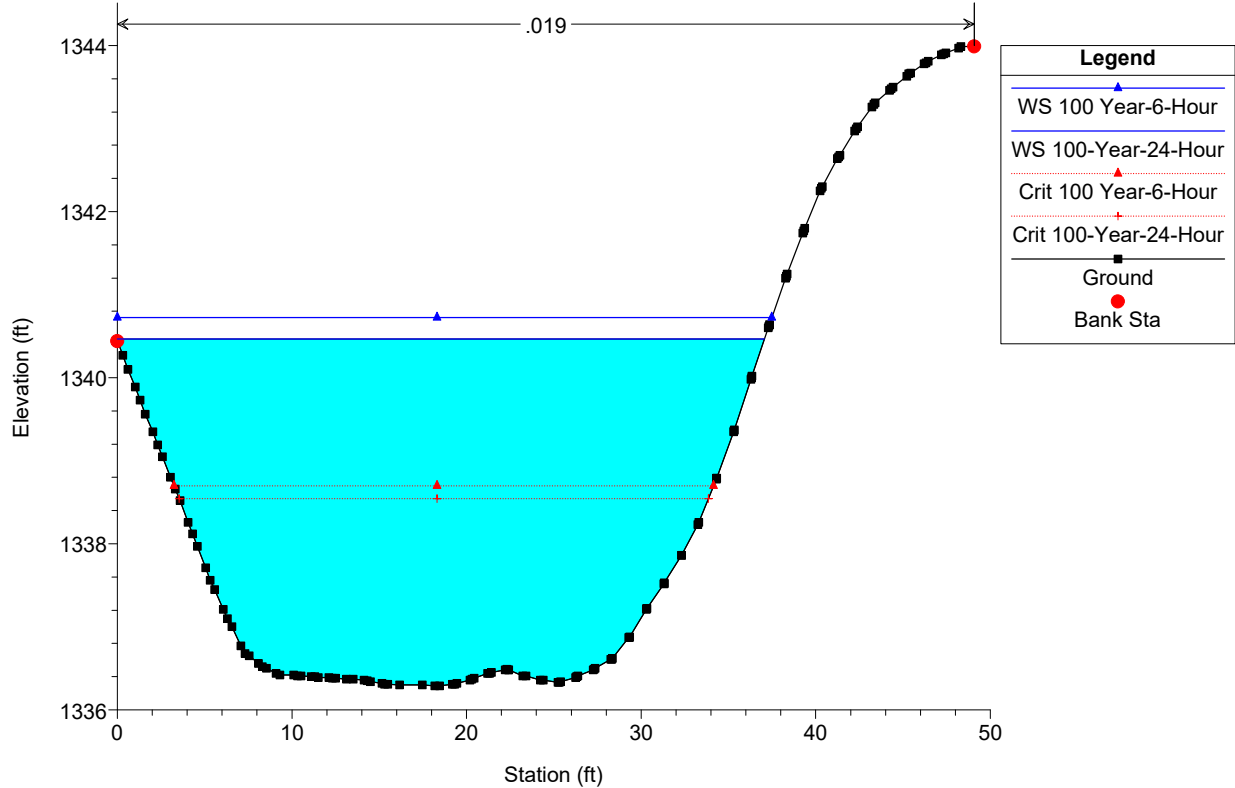
Gold Dust Aprt Plan: Gold Dust Aprt Pre-Project 9/1/2022
RS = 1839



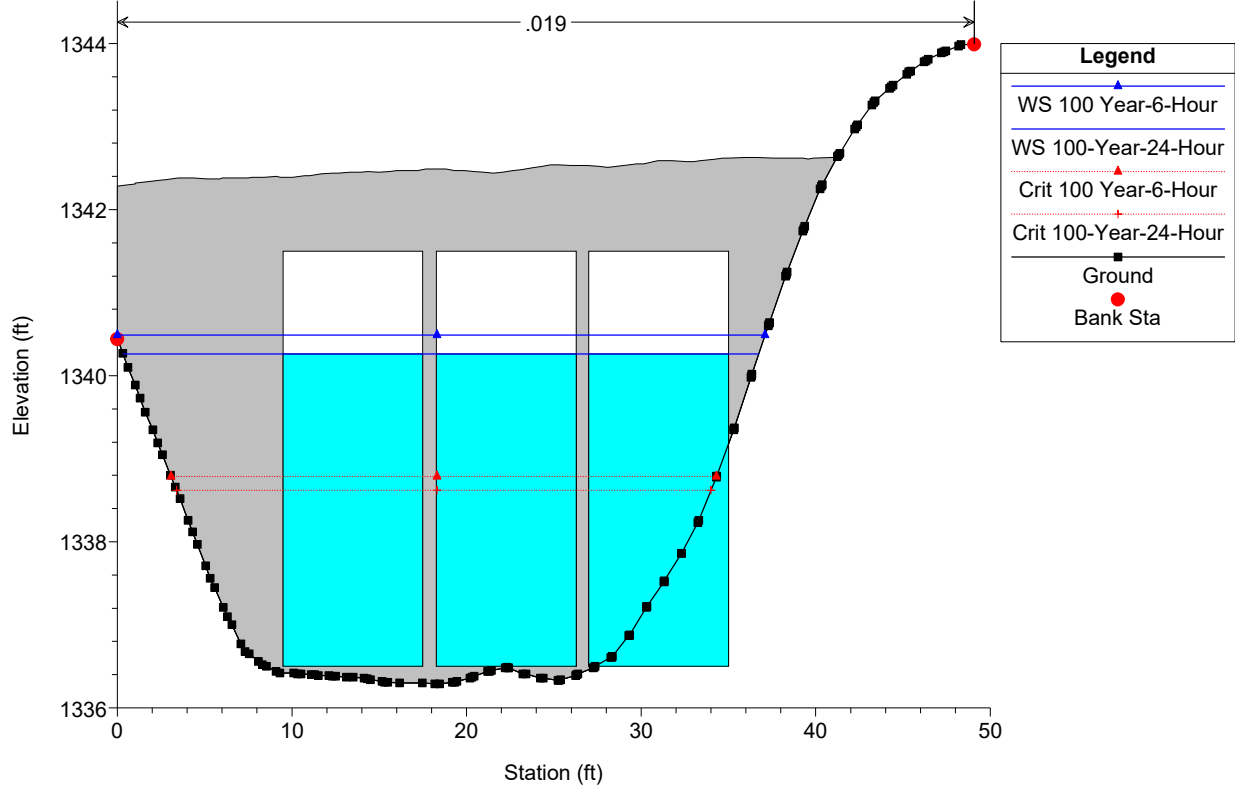
Gold Dust Aprt Plan: Gold Dust Aprt Pre-Project 9/1/2022
RS = 1753



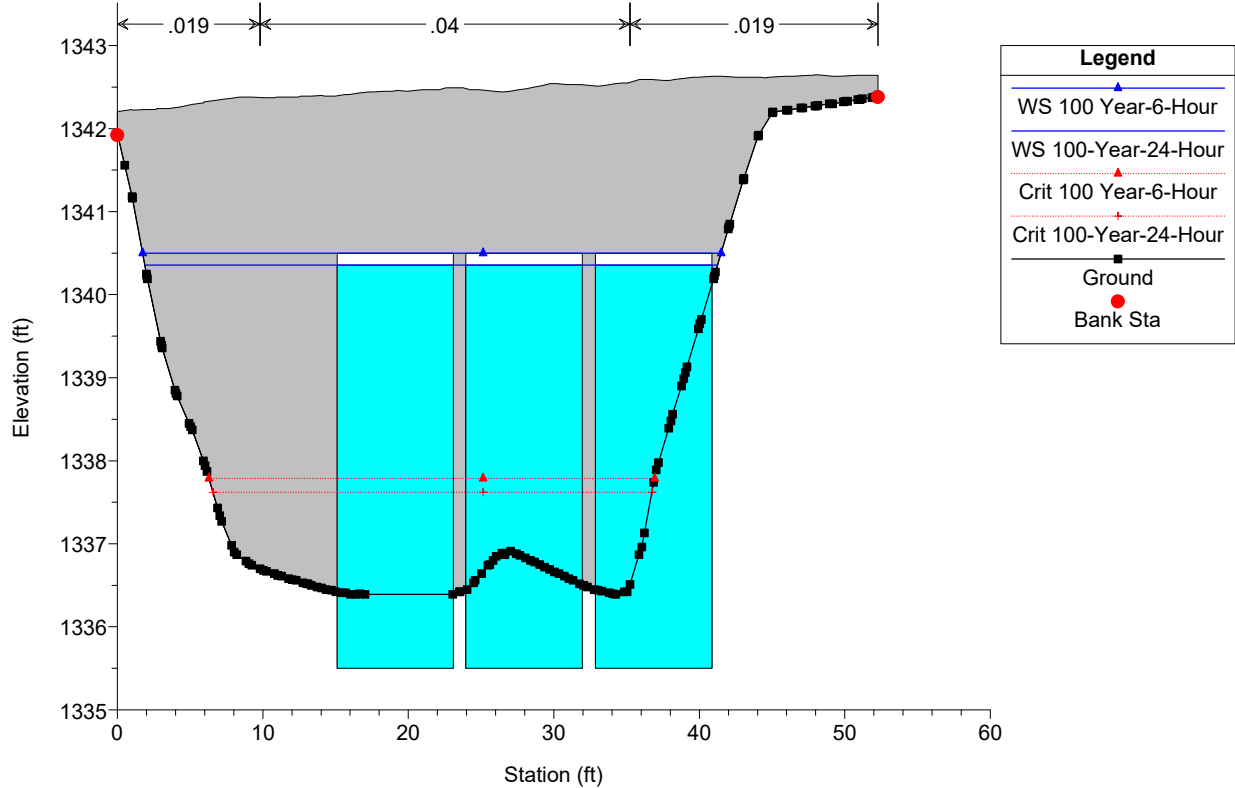
Gold Dust Aprt Plan: Gold Dust Aprt Pre-Project 9/1/2022
RS = 1682



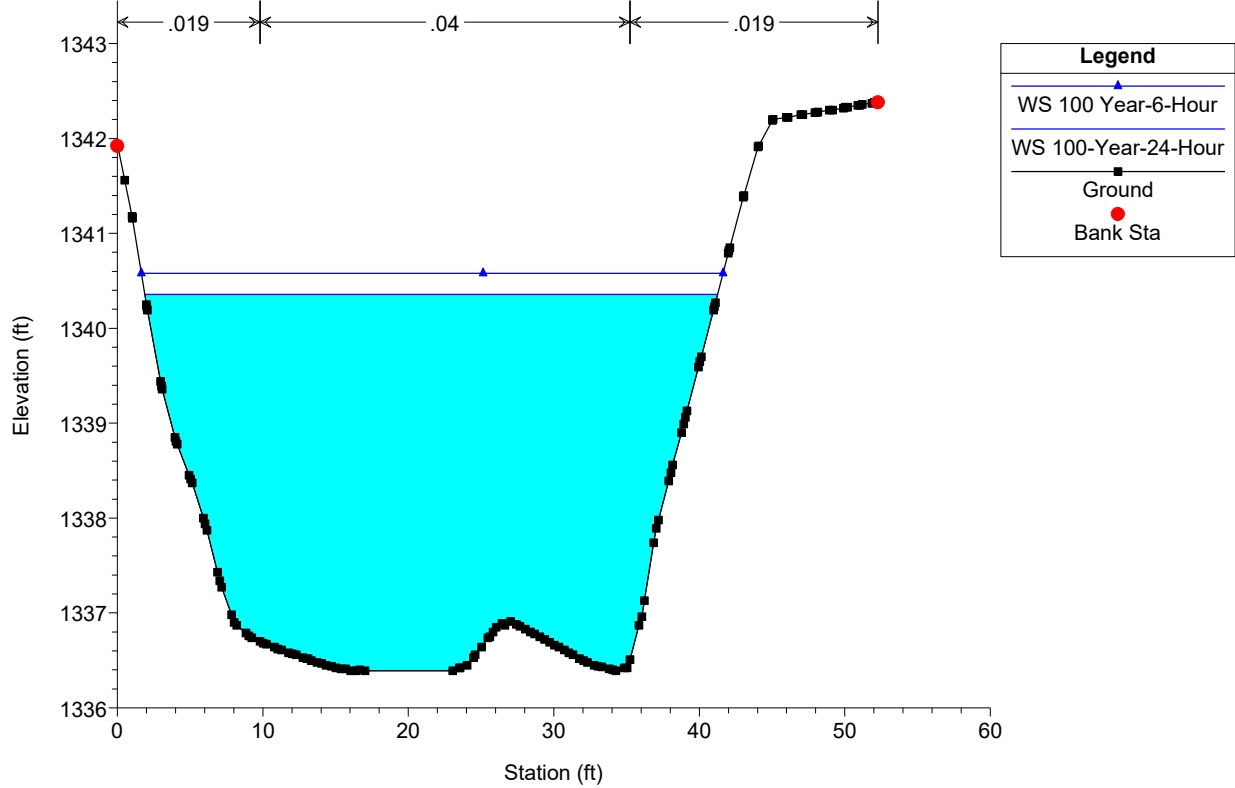
Gold Dust Aprt Plan: Gold Dust Aprt Pre-Project 9/1/2022
 RS = 1628 Culv Gold Dust Avenue



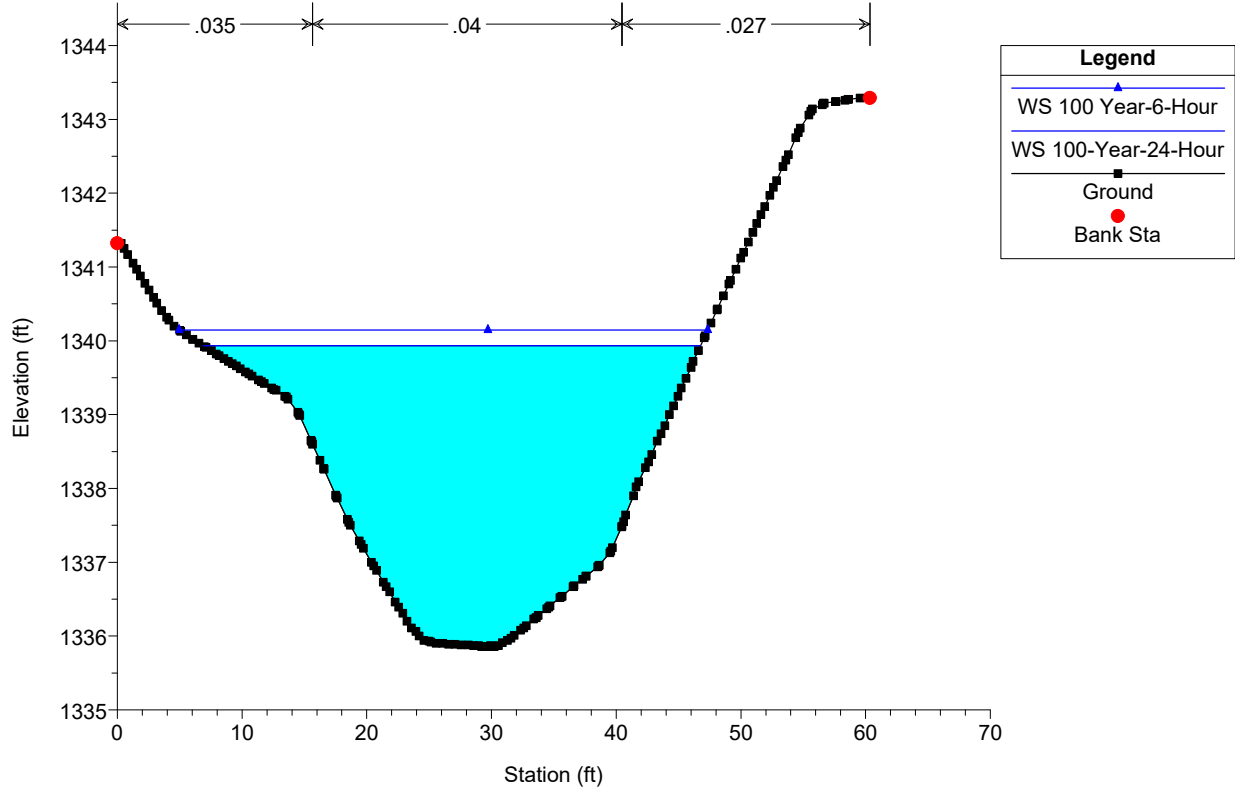
Gold Dust Aprt Plan: Gold Dust Aprt Pre-Project 9/1/2022
 RS = 1628 Culv Gold Dust Avenue

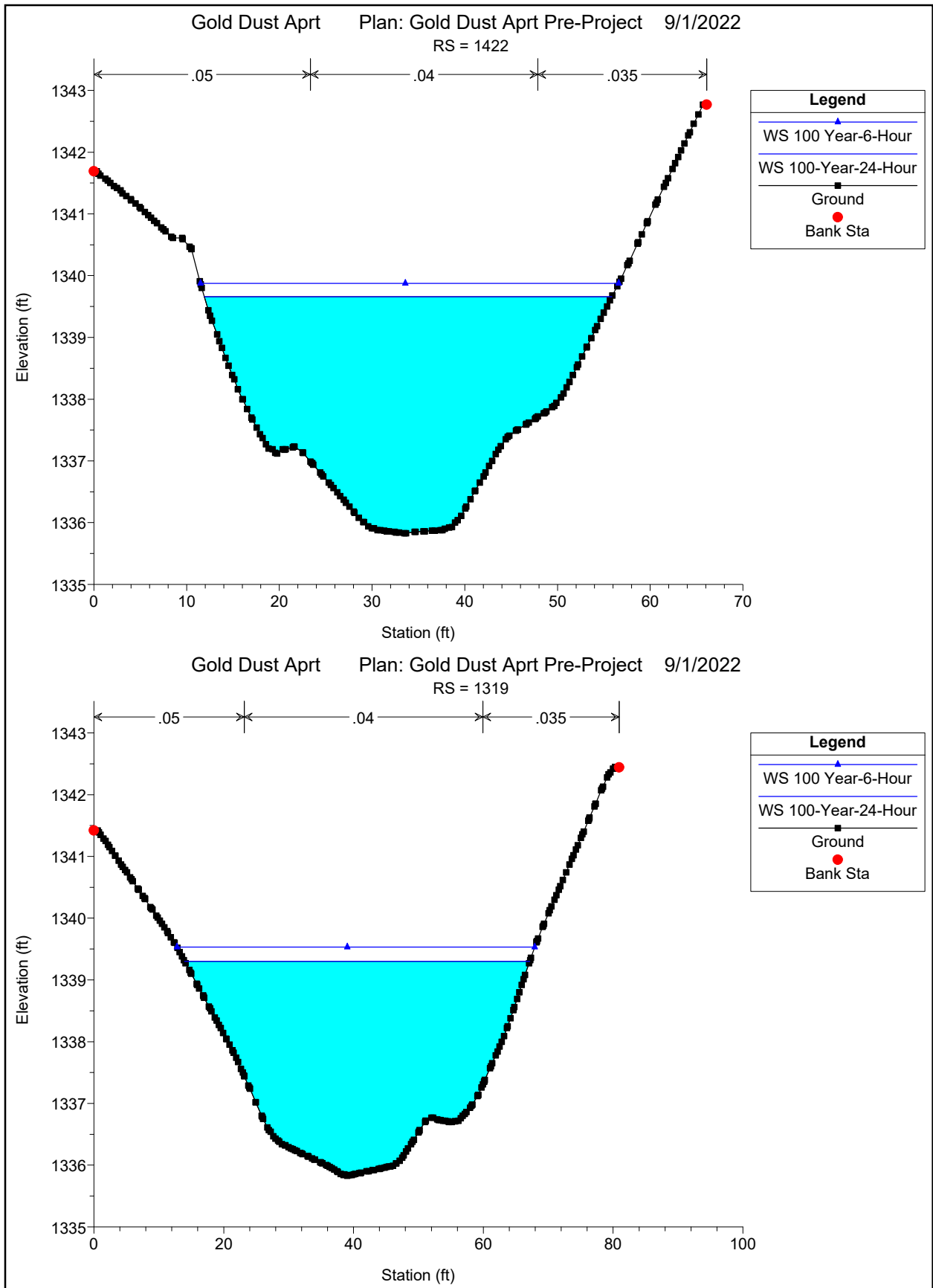


Gold Dust Aprt Plan: Gold Dust Aprt Pre-Project 9/1/2022
RS = 1572

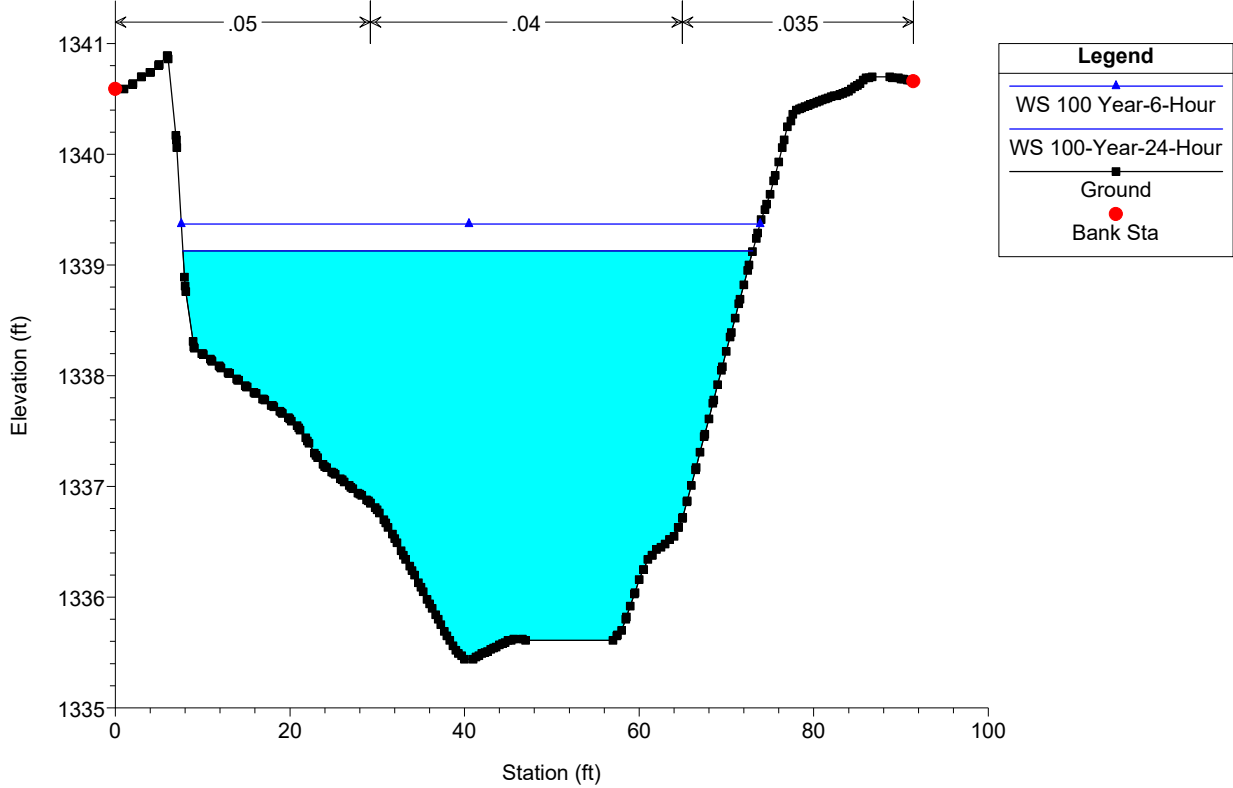


Gold Dust Aprt Plan: Gold Dust Aprt Pre-Project 9/1/2022
RS = 1496

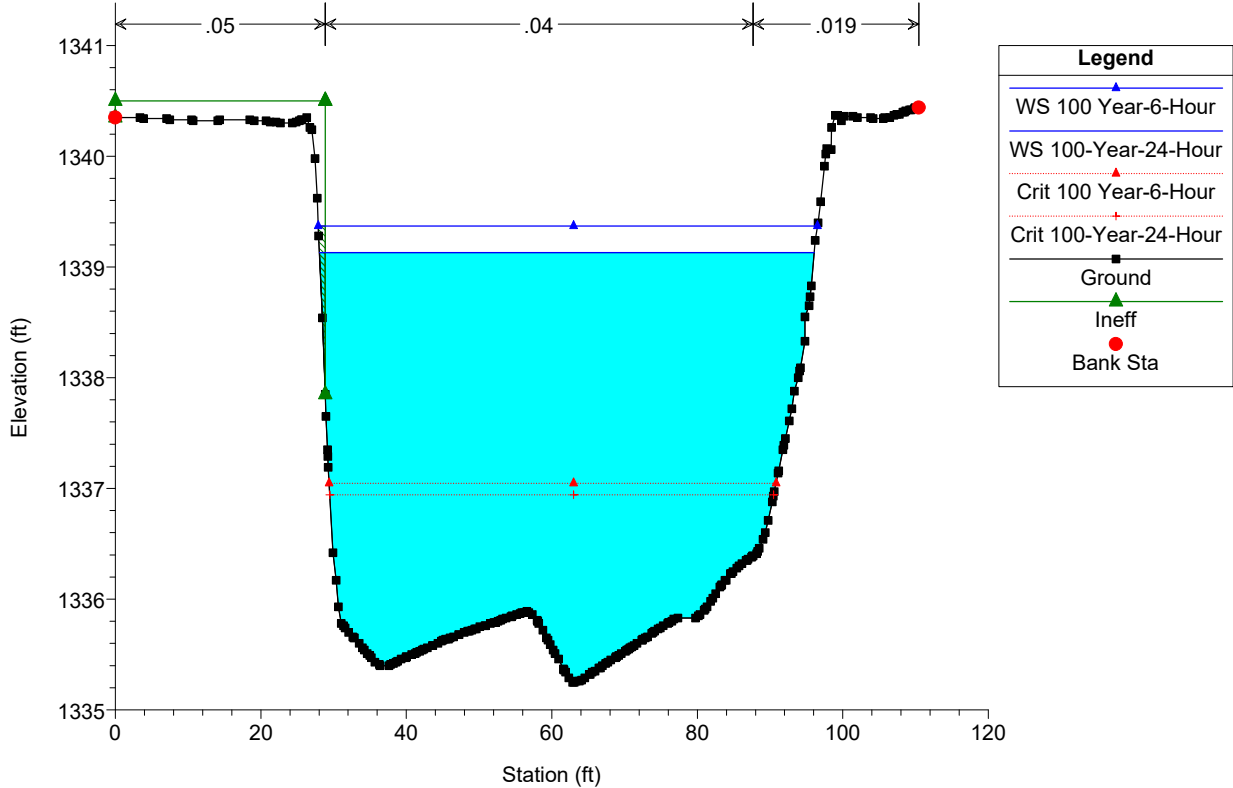




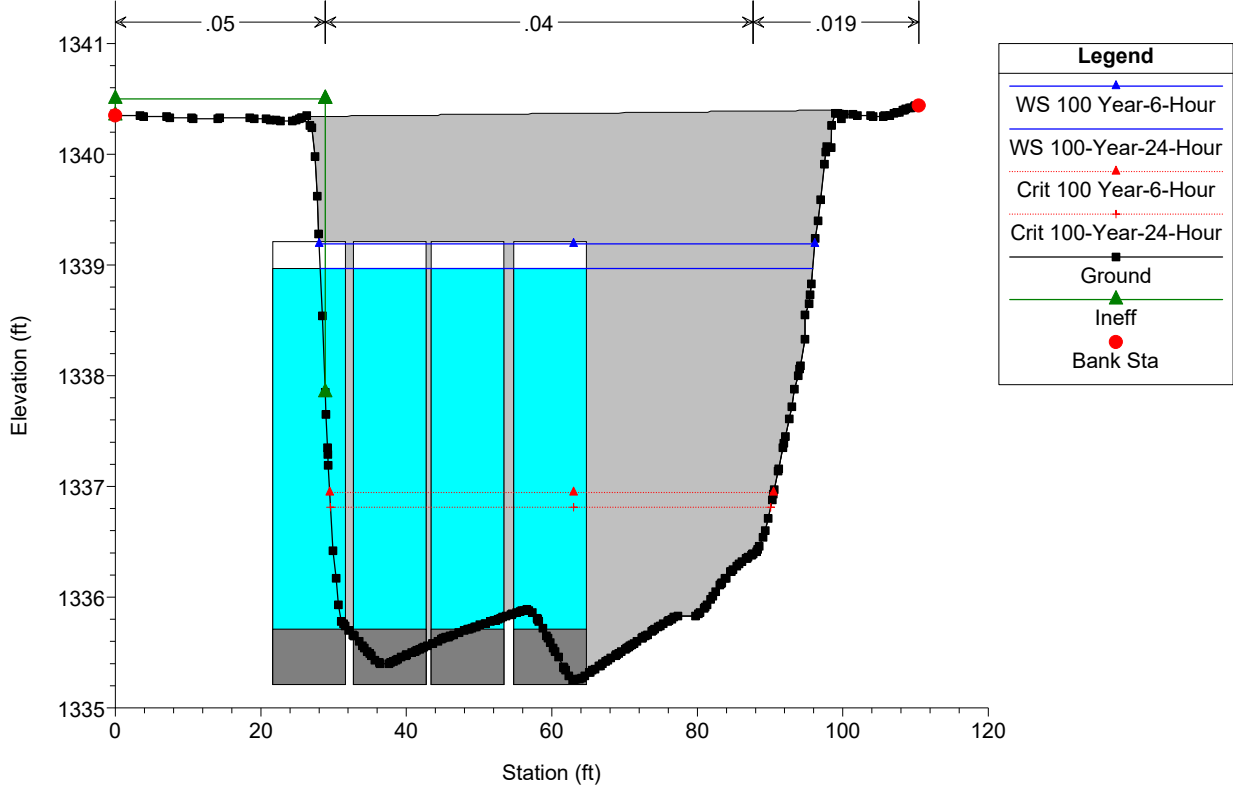
Gold Dust Aprt Plan: Gold Dust Aprt Pre-Project 9/1/2022
RS = 1223



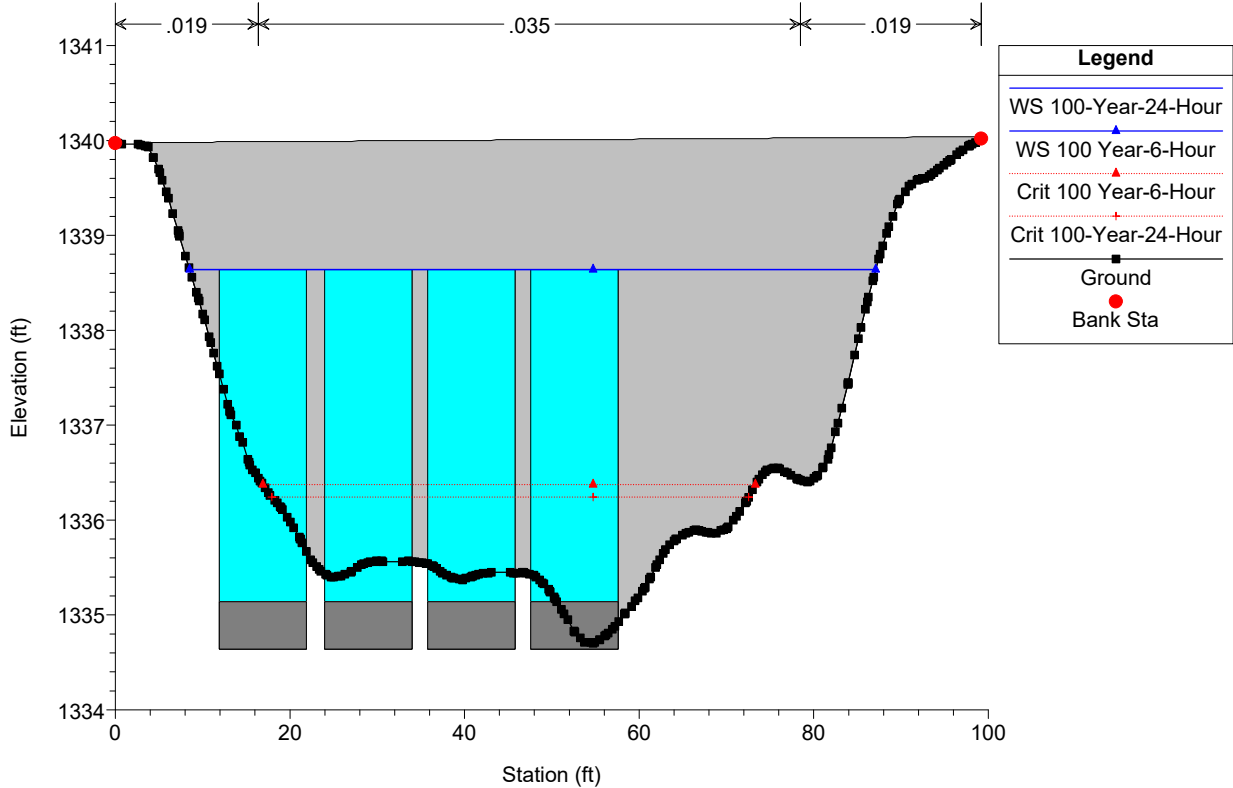
Gold Dust Aprt Plan: Gold Dust Aprt Pre-Project 9/1/2022
RS = 1193

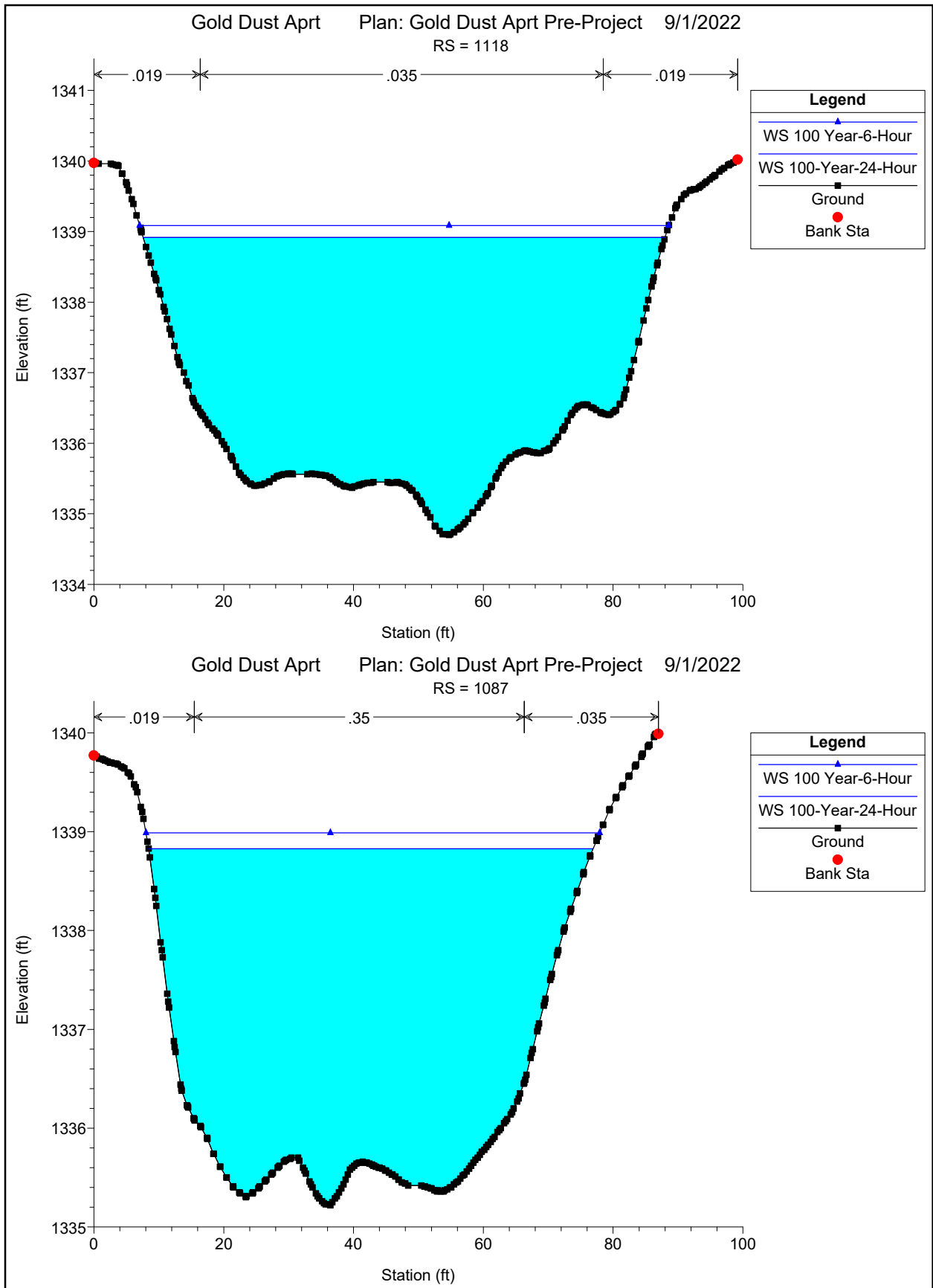


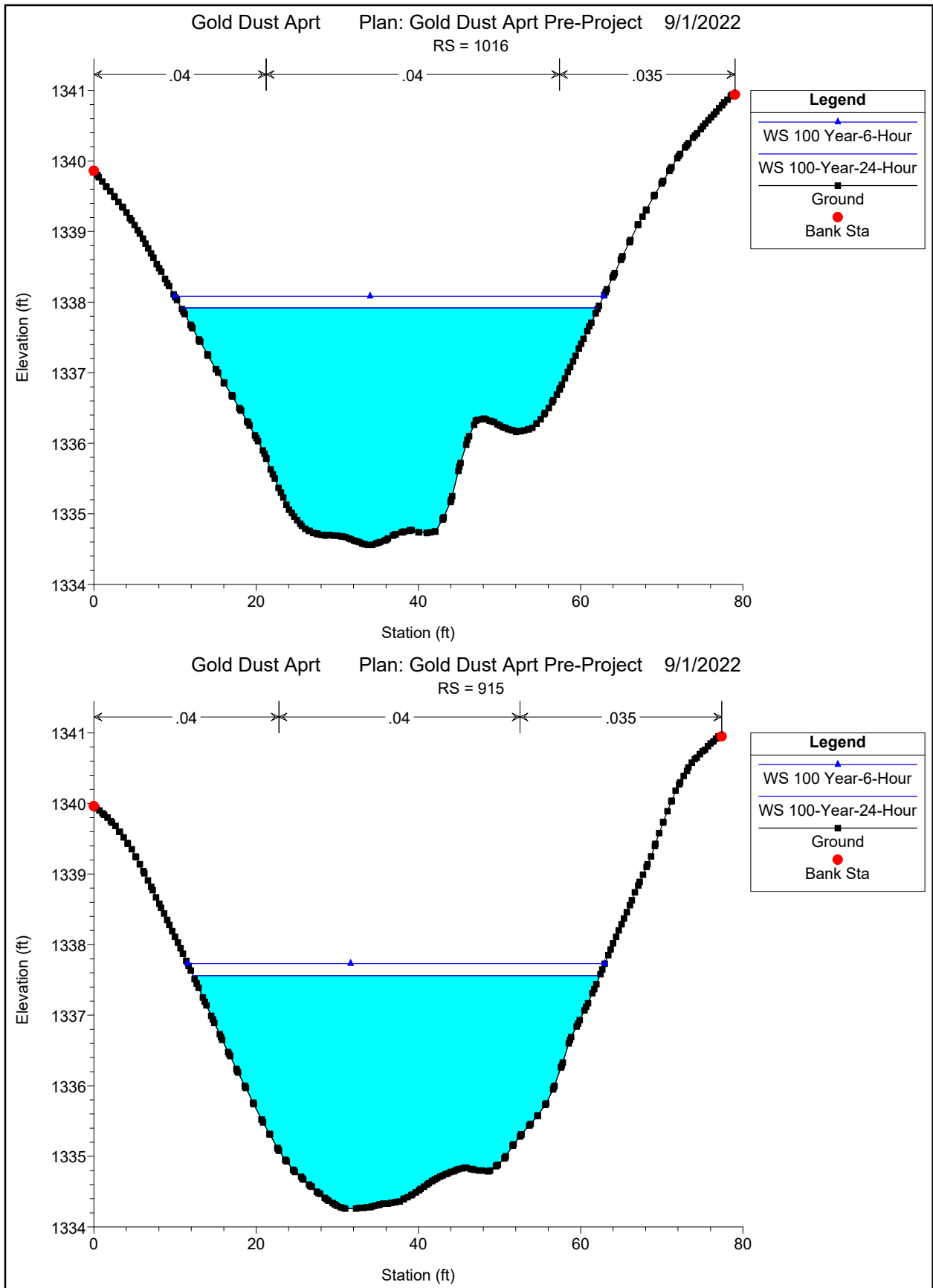
Gold Dust Aprt Plan: Gold Dust Aprt Pre-Project 9/1/2022
 RS = 1154 Culv Private Driveway



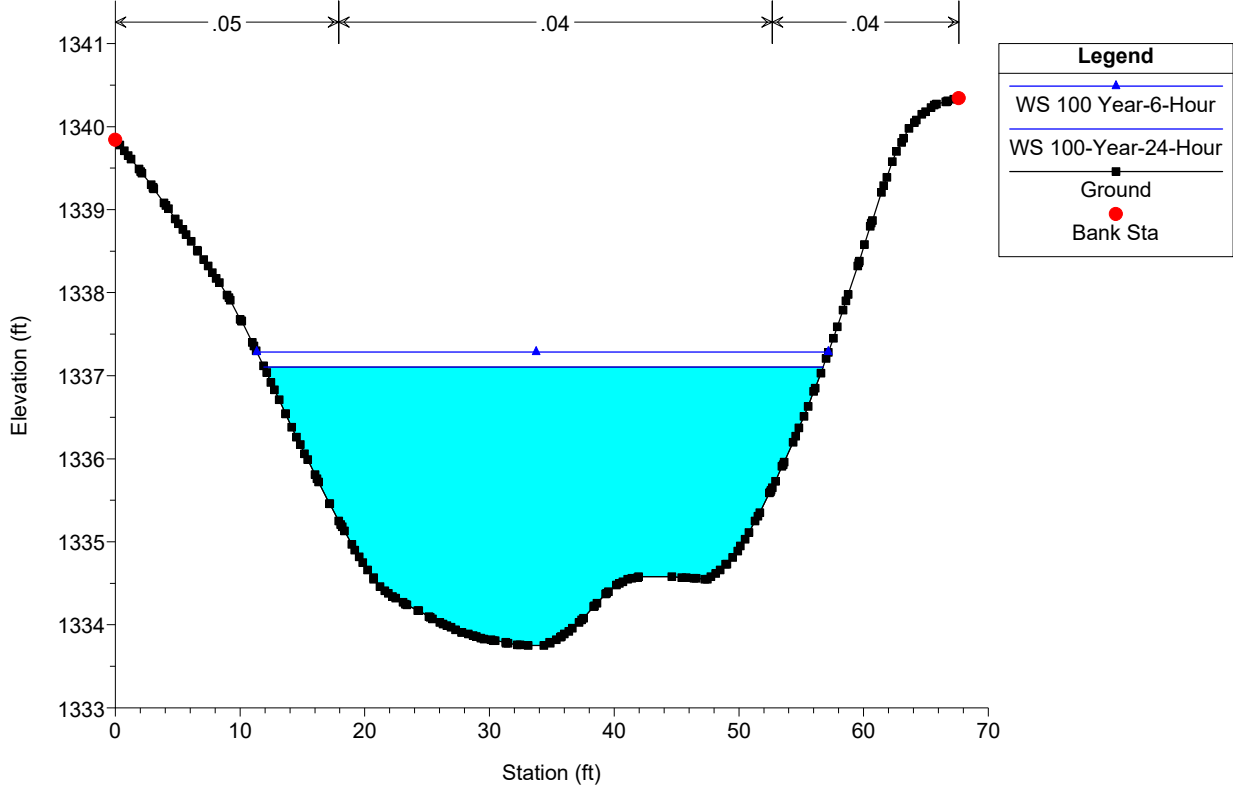
Gold Dust Aprt Plan: Gold Dust Aprt Pre-Project 9/1/2022
 RS = 1154 Culv Private Driveway



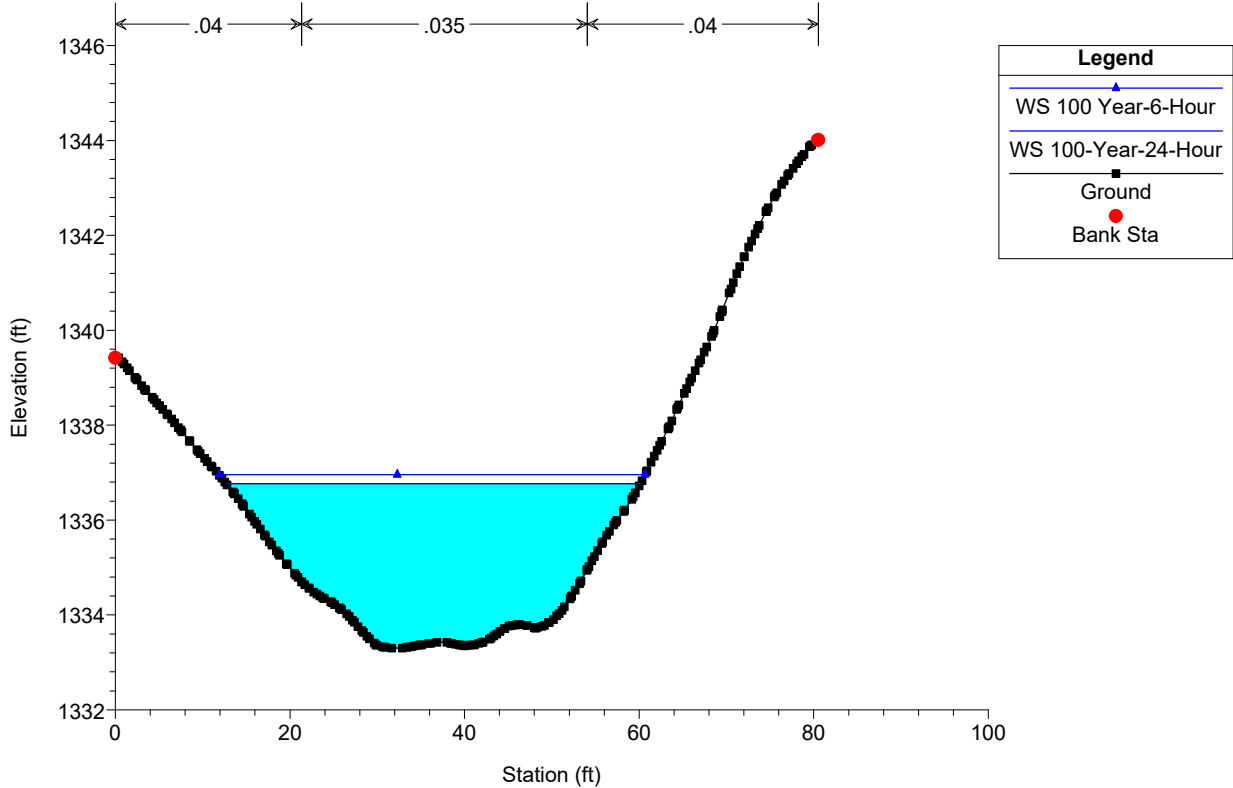




Gold Dust Aprt Plan: Gold Dust Aprt Pre-Project 9/1/2022
RS = 812

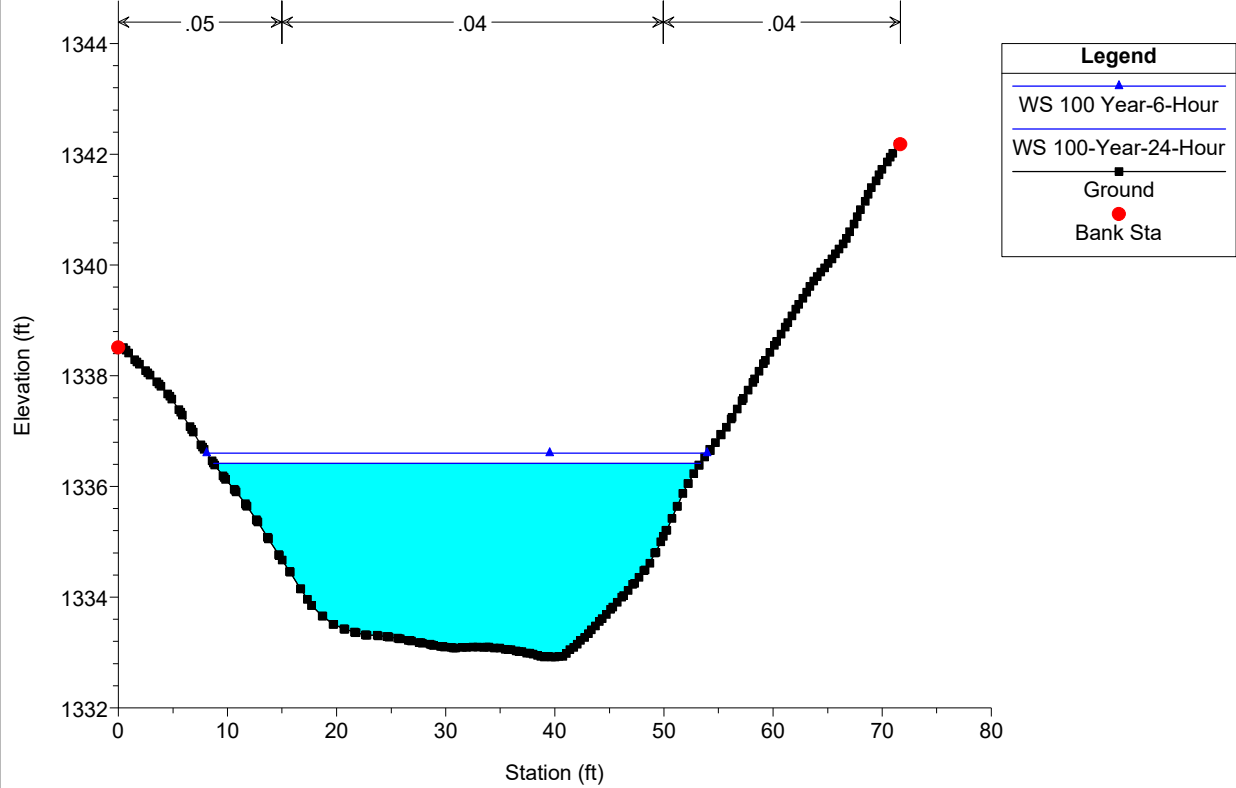


Gold Dust Aprt Plan: Gold Dust Aprt Pre-Project 9/1/2022
RS = 712



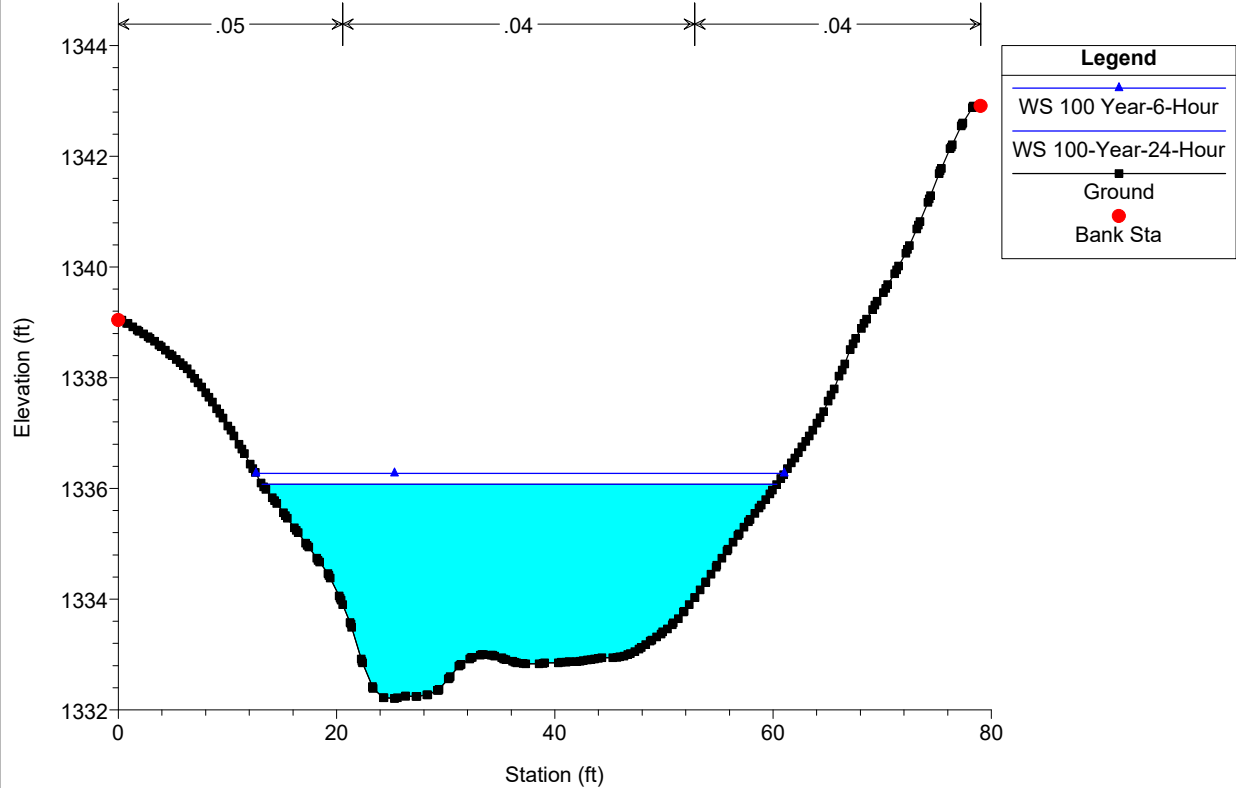
Gold Dust Aprt Plan: Gold Dust Aprt Pre-Project 9/1/2022

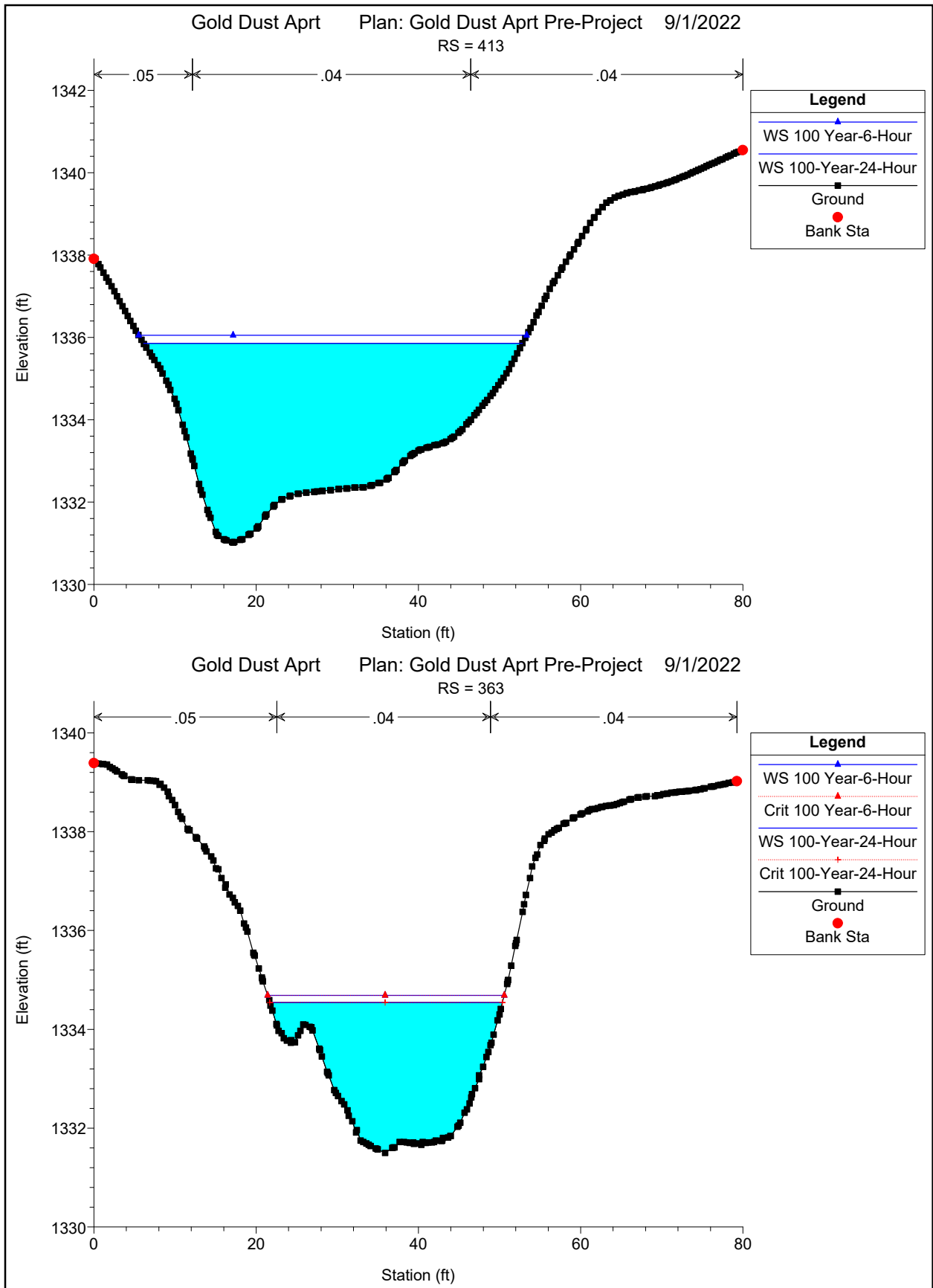
RS = 609



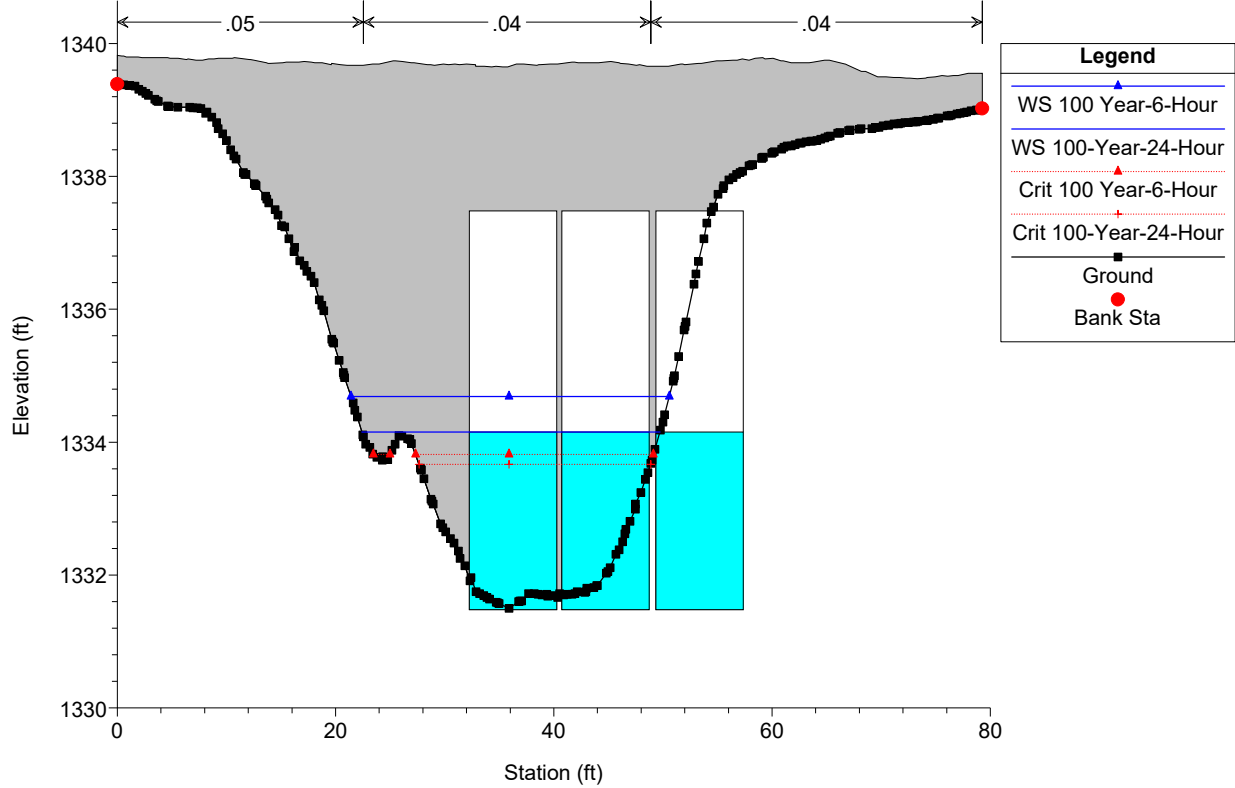
Gold Dust Aprt Plan: Gold Dust Aprt Pre-Project 9/1/2022

RS = 508

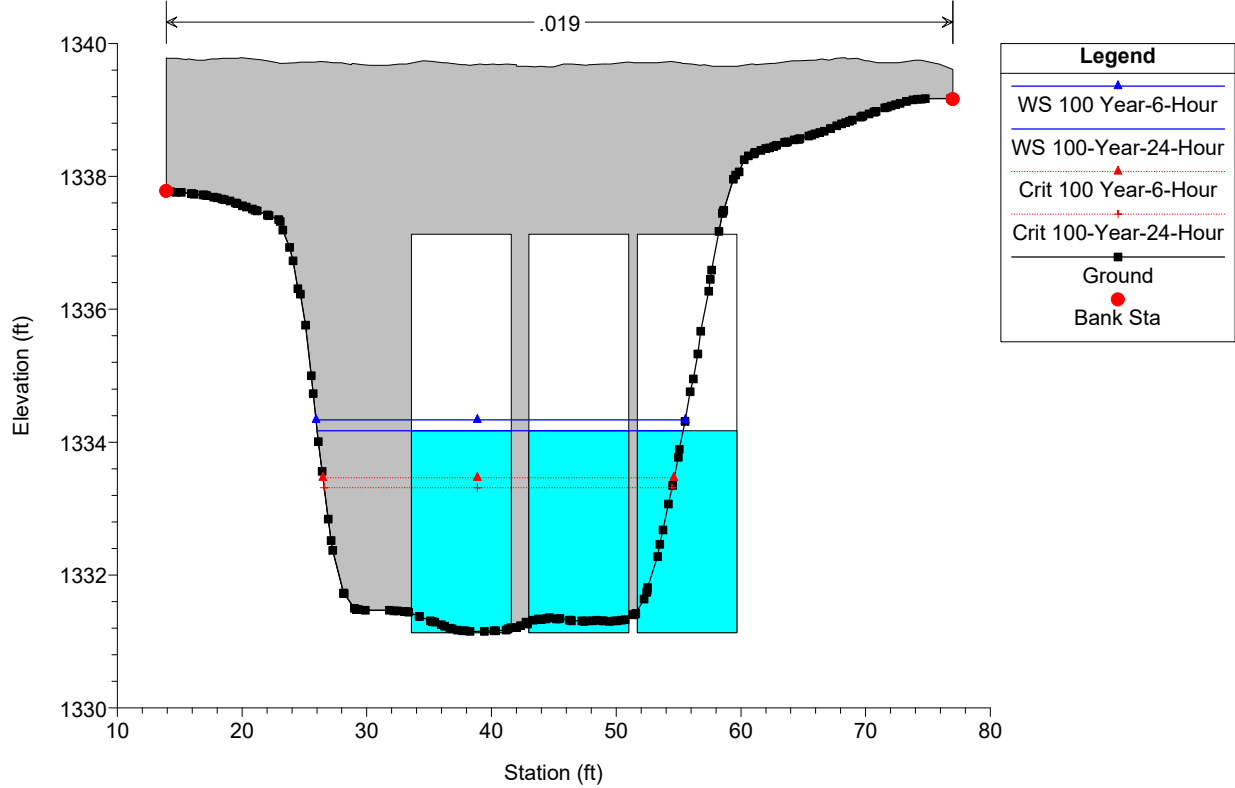


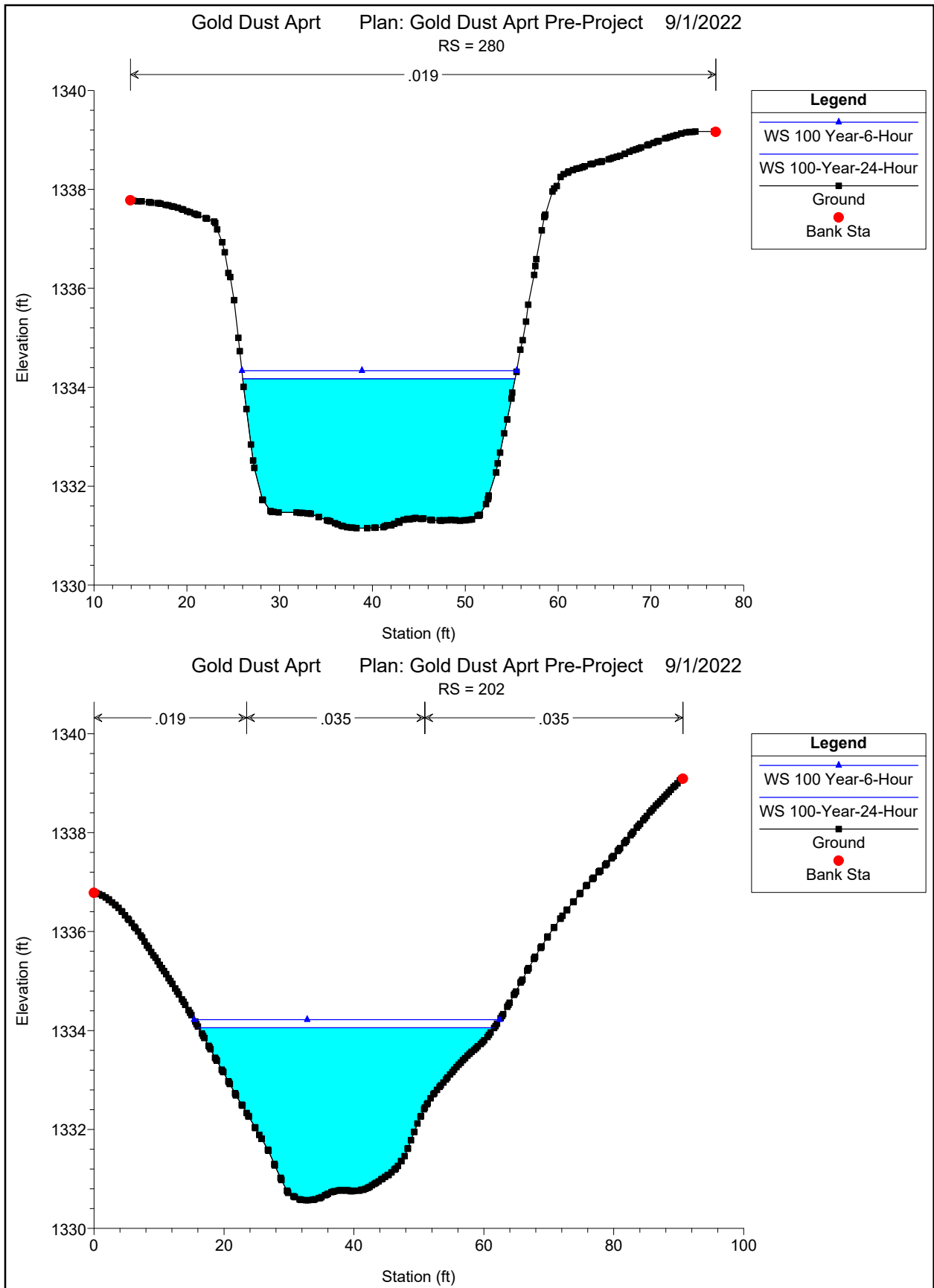


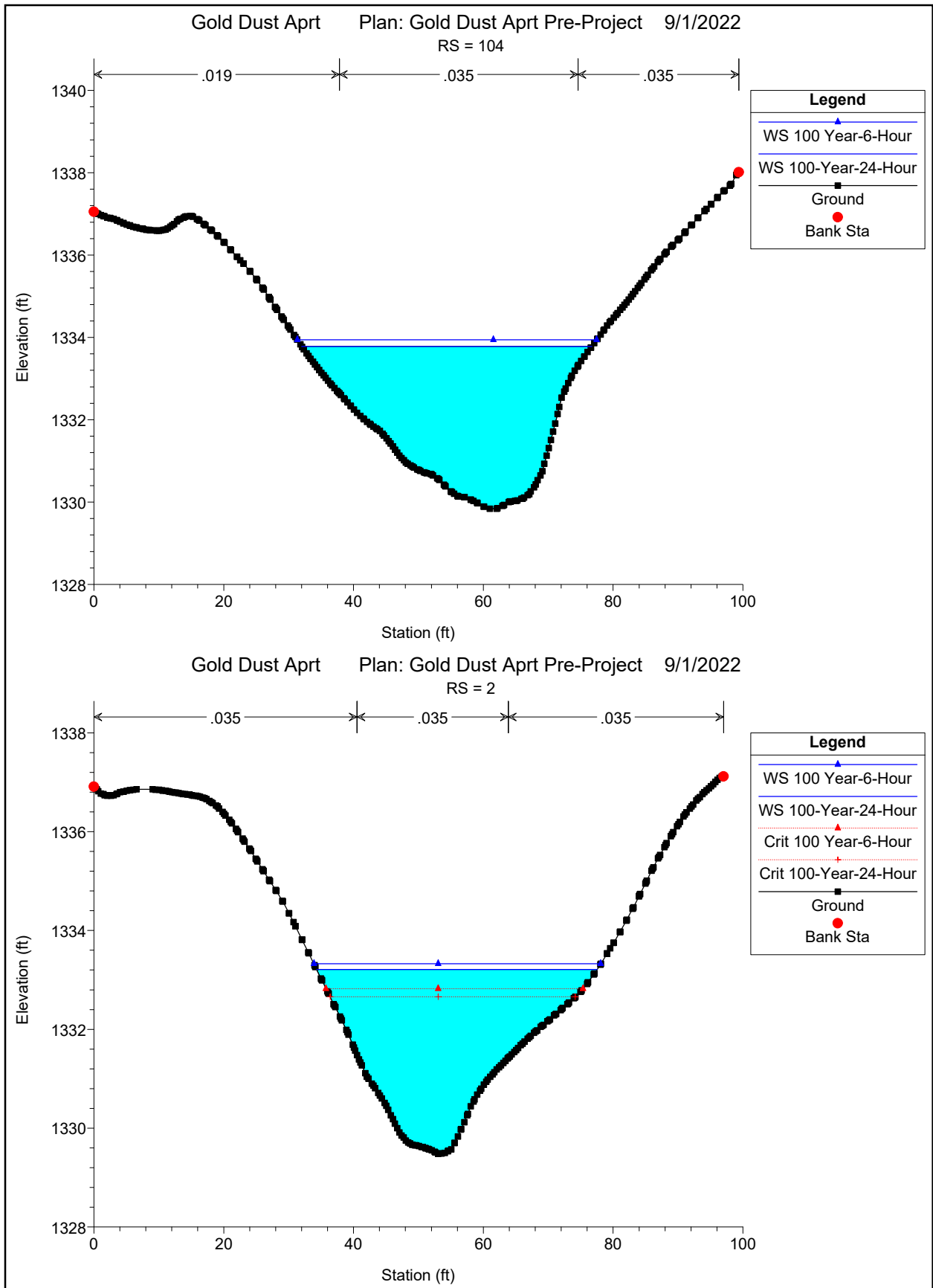
Gold Dust Aprt Plan: Gold Dust Aprt Pre-Project 9/1/2022
 RS = 326 Culv Mountain View Road

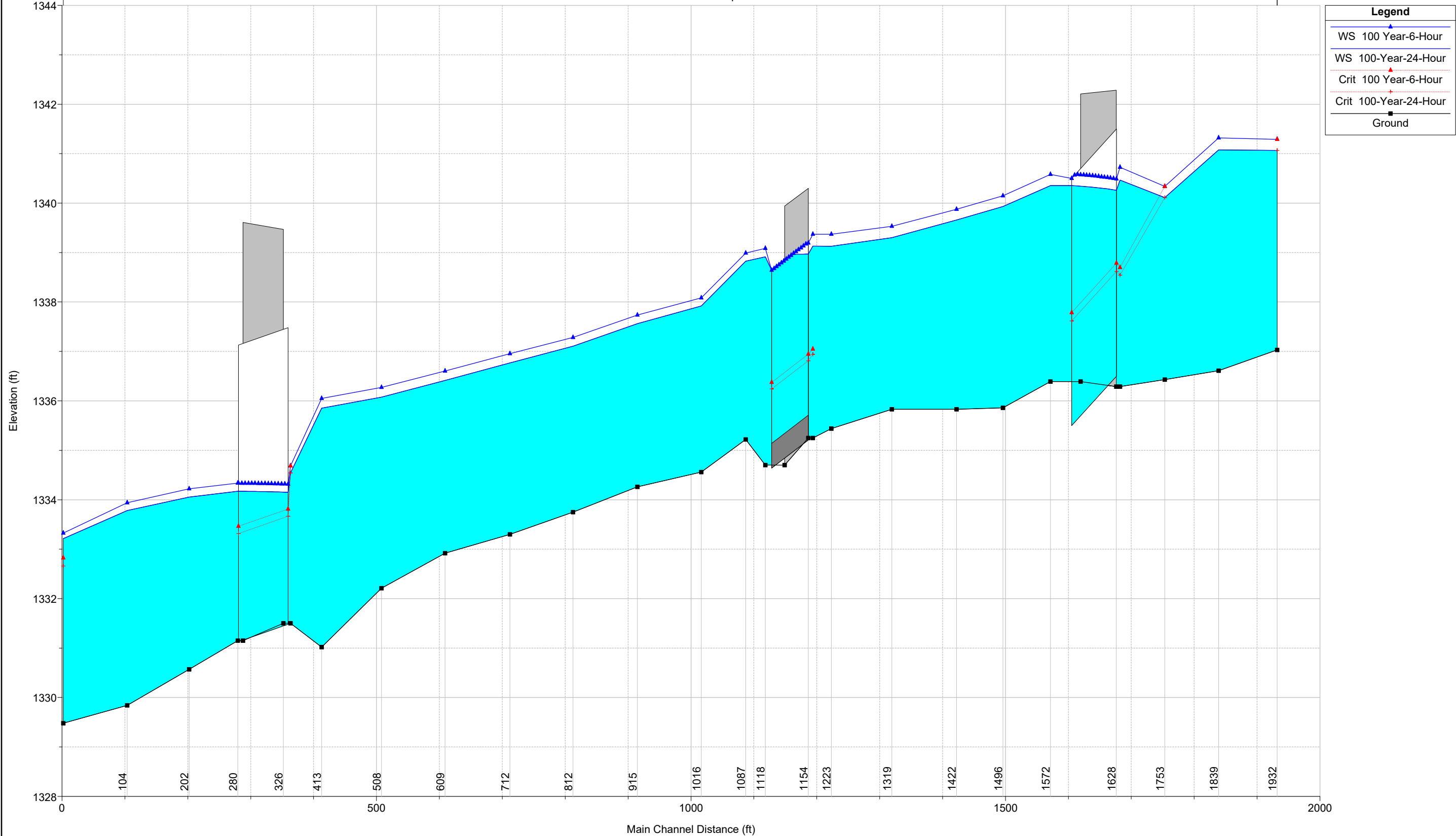


Gold Dust Aprt Plan: Gold Dust Aprt Pre-Project 9/1/2022
 RS = 326 Culv Mountain View Road









HEC-RAS Plan: Gold Dust Aprt Pre-Project River: Unnamed Wash Reach: Gold Dust Aprt.

Reach	River Sta	Profile	Q Total (cfs)	Min Ch El (ft)	W.S. Elev (ft)	Crit W.S. (ft)	E.G. Elev (ft)	E.G. Slope (ft/ft)	Vel Chnl (ft/s)	Flow Area (sq ft)	Top Width (ft)	Froude # Chl
Gold Dust Aprt.	1932	100-Year-24-Hour	420.00	1337.03	1341.07	1341.07	1342.27	0.004485	8.79	47.80	20.25	1.01
Gold Dust Aprt.	1932	100 Year-6-Hour	470.00	1337.03	1341.29	1341.29	1342.54	0.004416	8.97	52.42	21.29	1.01
Gold Dust Aprt.	1839	100-Year-24-Hour	420.00	1336.61	1341.08		1341.60	0.001441	5.78	72.73	24.75	0.59
Gold Dust Aprt.	1839	100 Year-6-Hour	470.00	1336.61	1341.32		1341.87	0.001450	5.96	78.84	25.66	0.60
Gold Dust Aprt.	1753	100-Year-24-Hour	420.00	1336.43	1340.11	1340.11	1341.33	0.004452	8.84	47.52	19.89	1.01
Gold Dust Aprt.	1753	100 Year-6-Hour	470.00	1336.43	1340.34	1340.34	1341.60	0.004325	9.02	52.13	20.67	1.00
Gold Dust Aprt.	1682	100-Year-24-Hour	420.00	1336.29	1340.47	1338.54	1340.66	0.000451	3.51	119.65	37.06	0.34
Gold Dust Aprt.	1682	100 Year-6-Hour	470.00	1336.29	1340.73	1338.70	1340.93	0.000447	3.63	129.33	37.49	0.34
Gold Dust Aprt.	1628		Culvert									
Gold Dust Aprt.	1572	100-Year-24-Hour	420.00	1336.39	1340.36		1340.53	0.001221	3.33	126.25	39.36	0.33
Gold Dust Aprt.	1572	100 Year-6-Hour	470.00	1336.39	1340.58		1340.77	0.001232	3.48	135.15	39.98	0.33
Gold Dust Aprt.	1496	100-Year-24-Hour	460.00	1335.86	1339.93		1340.30	0.004799	4.86	94.61	39.88	0.56
Gold Dust Aprt.	1496	100 Year-6-Hour	518.00	1335.86	1340.15		1340.54	0.004845	5.01	103.41	42.38	0.57
Gold Dust Aprt.	1422	100-Year-24-Hour	460.00	1335.83	1339.66		1339.94	0.004353	4.22	108.98	43.95	0.47
Gold Dust Aprt.	1422	100 Year-6-Hour	518.00	1335.83	1339.88		1340.17	0.004312	4.37	118.61	45.11	0.47
Gold Dust Aprt.	1319	100-Year-24-Hour	460.00	1335.83	1339.30		1339.52	0.003524	3.72	123.51	53.19	0.43
Gold Dust Aprt.	1319	100 Year-6-Hour	518.00	1335.83	1339.53		1339.76	0.003419	3.81	136.03	55.14	0.43
Gold Dust Aprt.	1223	100-Year-24-Hour	460.00	1335.44	1339.13		1339.26	0.001741	2.93	157.05	65.27	0.33
Gold Dust Aprt.	1223	100 Year-6-Hour	518.00	1335.44	1339.37		1339.51	0.001667	2.99	172.99	66.29	0.33
Gold Dust Aprt.	1193	100-Year-24-Hour	460.00	1335.25	1339.13	1336.94	1339.20	0.000639	2.14	214.93	68.02	0.21
Gold Dust Aprt.	1193	100 Year-6-Hour	518.00	1335.25	1339.37	1337.05	1339.45	0.000636	2.24	231.26	68.63	0.21
Gold Dust Aprt.	1154		Culvert									
Gold Dust Aprt.	1118	100-Year-24-Hour	460.00	1334.70	1338.92		1338.98	0.000436	1.98	232.89	80.40	0.20
Gold Dust Aprt.	1118	100 Year-6-Hour	518.00	1334.70	1339.09		1339.15	0.000460	2.10	246.73	81.52	0.21
Gold Dust Aprt.	1087	100-Year-24-Hour	460.00	1335.22	1338.83		1338.92	0.059473	2.45	187.61	68.45	0.26
Gold Dust Aprt.	1087	100 Year-6-Hour	518.00	1335.22	1338.99		1339.09	0.062155	2.60	198.88	69.91	0.27
Gold Dust Aprt.	1016	100-Year-24-Hour	440.00	1334.56	1337.92		1338.18	0.003942	4.10	107.43	51.38	0.50
Gold Dust Aprt.	1016	100 Year-6-Hour	485.00	1334.56	1338.08		1338.35	0.003834	4.18	115.95	52.85	0.50
Gold Dust Aprt.	915	100-Year-24-Hour	440.00	1334.26	1337.56		1337.79	0.003515	3.86	113.86	50.15	0.45
Gold Dust Aprt.	915	100 Year-6-Hour	485.00	1334.26	1337.73		1337.98	0.003448	3.96	122.63	51.46	0.45
Gold Dust Aprt.	812	100-Year-24-Hour	440.00	1333.75	1337.11		1337.38	0.004566	4.21	104.58	44.83	0.49
Gold Dust Aprt.	812	100 Year-6-Hour	485.00	1333.75	1337.28		1337.57	0.004487	4.31	112.64	45.83	0.48
Gold Dust Aprt.	712	100-Year-24-Hour	440.00	1333.30	1336.77		1337.00	0.002967	3.89	112.97	47.48	0.45
Gold Dust Aprt.	712	100 Year-6-Hour	485.00	1333.30	1336.96		1337.20	0.002917	3.98	121.93	48.81	0.44
Gold Dust Aprt.	609	100-Year-24-Hour	440.00	1332.92	1336.41		1336.66	0.003776	3.98	110.68	44.60	0.44
Gold Dust Aprt.	609	100 Year-6-Hour	485.00	1332.92	1336.60		1336.86	0.003740	4.07	119.22	45.88	0.44
Gold Dust Aprt.	508	100-Year-24-Hour	440.00	1332.21	1336.08		1336.29	0.003331	3.73	117.99	47.18	0.42
Gold Dust Aprt.	508	100 Year-6-Hour	485.00	1332.21	1336.27		1336.50	0.003264	3.81	127.36	48.43	0.41
Gold Dust Aprt.	413	100-Year-24-Hour	440.00	1331.02	1335.85		1336.02	0.002207	3.31	133.11	46.67	0.35
Gold Dust Aprt.	413	100 Year-6-Hour	485.00	1331.02	1336.05		1336.23	0.002225	3.41	142.39	47.82	0.35
Gold Dust Aprt.	363	100-Year-24-Hour	440.00	1331.50	1334.54	1334.54	1335.53	0.020865	7.97	55.23	28.69	1.01
Gold Dust Aprt.	363	100 Year-6-Hour	485.00	1331.50	1334.69	1334.69	1335.72	0.020559	8.17	59.34	29.18	1.01
Gold Dust Aprt.	326		Culvert									
Gold Dust Aprt.	280	100-Year-24-Hour	440.00	1331.15	1334.17		1334.70	0.001704	5.80	75.90	29.35	0.64
Gold Dust Aprt.	280	100 Year-6-Hour	485.00	1331.15	1334.34		1334.90	0.001718	6.01	80.70	29.62	0.64
Gold Dust Aprt.	202	100-Year-24-Hour	470.00	1330.57	1334.05		1334.43	0.003746	4.94	95.12	45.49	0.60
Gold Dust Aprt.	202	100 Year-6-Hour	526.00	1330.57	1334.22		1334.63	0.003769	5.12	102.82	47.04	0.61
Gold Dust Aprt.	104	100-Year-24-Hour	470.00	1329.84	1333.78		1334.08	0.002946	4.42	106.32	44.71	0.51
Gold Dust Aprt.	104	100 Year-6-Hour	526.00	1329.84	1333.94		1334.27	0.003020	4.63	113.58	46.12	0.52
Gold Dust Aprt.	2	100-Year-24-Hour	470.00	1329.48	1333.21	1332.66	1333.68	0.005215	5.47	85.96	43.24	0.68
Gold Dust Aprt.	2	100 Year-6-Hour	526.00	1329.48	1333.33	1332.82	1333.85	0.005621	5.79	90.86	44.19	0.71



Appendix H – SCOUR AND LATERAL MIGRATION POTENTIAL CALCULATIONS

Channel Riprap Sizing

FCDMC Drainage Desing Manual for Maricopa County - Hydraulics 2018

6.6.3 Riprap Lined Channels

Channel Bank, Loose Angular Riprap Sizing (d50)

Input Parameters:

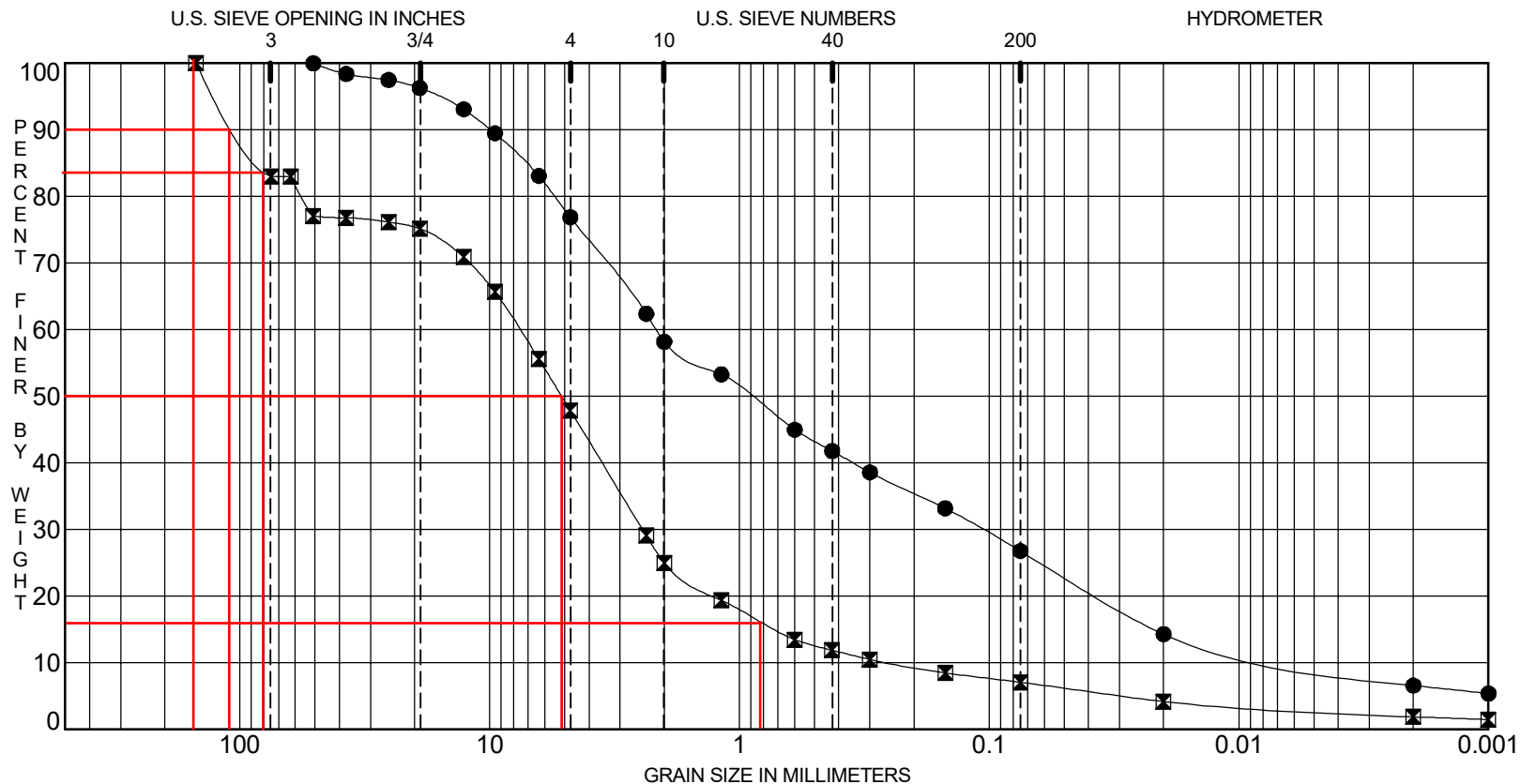
V _m , Maximum Channel Velocity	5.0	ft/s	(Max Vel from HEC-RAS Flow Dist Analysis is Entered Here)
γ _s , Spec Weight Stone	156		
φ, Bank Angle (from Horizontal)	18.4	Degrees	
C, Turbulence Coefficient	1.2		(Use 1.2 for low turbulence, 0.86 for high turbulence)
Minimum D ₅₀	0.19	ft	Use 4" Rock

Calculated By:

JEP

Date: 1/30/2023

GRADATION CURVES



COBBLES	GRAVEL		SAND			SILT OR CLAY
	coarse	fine	coarse	medium	fine	

	Specimen Identification		ASTM Classification			LL	PL	PI	%Gravel	%Sand	%Fines		
BANK	●	TP-1	0.0	CLAYEY SAND with GRAVEL			SC	40	20	20	23.1	50.1	26.8
BED	☒	TP-2	0.0	POORLY GRADED SAND with CLAY and GRAVEL			SP-SC	40	22	19	35.1	40.8	7.1

Gold Dust Apartments - Unnamed Wash Scour Summary

Dibble

Channel Scour

HEC-RAS Cross Section	General Scour ¹ (ft)	Bend Scour ² (ft)	Bedform Scour ³ (ft)	Long Term Scour ⁴ (ft)	Low Flow Thalweg ⁵ (ft)	Local Scour ⁶ (ft)	Safety Factor ⁷	Total Scour Depth ⁸ (ft)
1496	1.7	0.0	0.1	0.0	0.0	0.0	1.3	2.3
1422	1.7	0.0	0.1	0.0	0.0	0.0	1.3	2.3
1319	1.7	0.0	0.1	0.0	0.0	0.0	1.3	2.3
1223	1.7	0.0	0.1	0.0	0.0	0.0	1.3	2.3

¹General scour calculated using Blench Equation, see attached.

²A moderate bend is included in the General Scour computation using Blench Equation

³Bedform Scour per USBR Dune and Anti-Dune Scour Height Calculations, see attached.

⁴Longterm Scour is set to zero due to immediate downstream control.

⁵Low Flow Scour is appropriate for constructed channels; scour depth is applied to the lowest point in each natural wash cross section, so Low Flow Scour has

⁶Local Control Scour depth - there are no local scour sources in the subject reach.

⁷A safety factor equal to 1.3 per Flood Control District of Maricopa County Drainage Design Manual - Hydraulics.

⁸Total Scour Depth is equal to the sum of General, Bend, Bedform, Long Term, Low Flow, and Local multiplied by the Safety Factor. Depth is applied to lowets

Soils Data:

Sediment Gradation	
D (mm)	% Finer
170.00	100
110.00	90
80.00	84
5.00	50
0.80	16

Calculated By:

JEP

Date:

1.30.2023

General Scour Calculations - USBR

* Methodology from US Bureau of Reclamation, "Computing Degradation and Local Scour", 1984 *

Blench Equation:

$$d_s = Z \frac{q_f^{2/3}}{F_{bo}^{1/3}}$$

Where:

ds = Scour Depth Below Streambed (ft)
 Z = Regime Modifier (See Table Below)
 * Moderate bend assumed *

Lacey Equation:

$$d_s = 0.47Z \left(\frac{Q}{1.76D_m^{1/2}} \right)^{1/3}$$

qf = Unit Discharge (Q/Top Width)
 Fbo = Blench's "zero bed factor" (ft/s²)
 Q = Design Discharge (cfs)
 Dm = Mean Grain Size of Bed Material (mm)
 Vm = Mean Channel Velocity (ft/s)
 Vc = Channel Competent Velocity (ft/s)
 dm = Mean Depth (ft)

Competent Velocity Equation:

$$d_s = d_m \left(\frac{V_m}{V_c} - 1 \right)$$

Input Parameters

Dm	5.00 mm
⁴ Longterm Scour is set to zero	518 cfs
Z	0.6
⁶ Local Control Scour depth	2.70 ft/s ²
Top Width	69 ft
Vc	- ft/s
Vm	- ft/s
dm	- ft

Scour Depths (from Channel Bottom)

Blench:	1.66 ft	1
Lacey:	N/A ft	2
Competent Vel:	N/A ft	3

1,2,3 1 Blench Method selected over Lacey and Competent Velocity methods.

Regime Modifier (Z)

Equation Types A and B	Equation Name		
	Neill	Lacey	Blench
Straight Reach	0.5	0.25	0.6
Moderate bend	0.6	0.5	0.6
Severe Bend	0.7	0.75	0.6
Right angle bends		1	1.25
Vertical rock bank or wall		1.25	

Equation Types C and D

Nose of piers	1		0.5-1.0
Nose of guide banks	0.4-0.7	1.5-1.75	1.0-1.75
Small dam or control across river		1.5	0.75-1.25

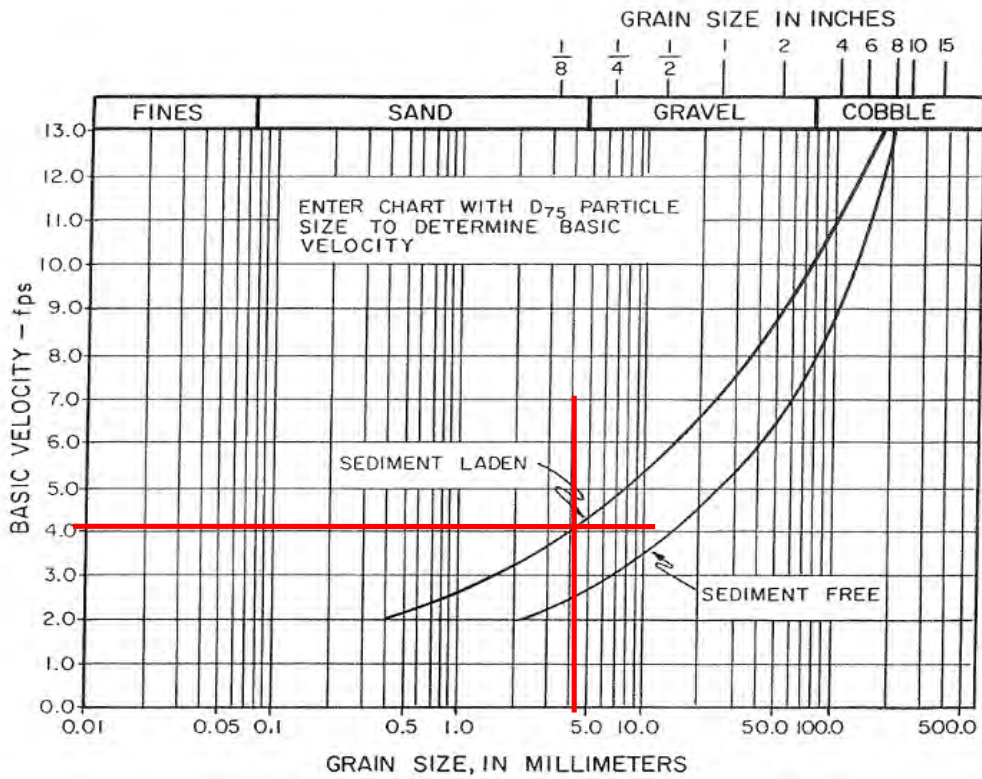
**Lateral Migration Setback Allowance for Riverine Floodplains
Level 2 Analysis**

Cross Section 1193 - General Information

Bottom Width (b)	60 feet		
Side Slope (ft)	22.9 Horizontal	4.3 Vertical	
Channel Slope (S_e)	0.0004 feet/foot		
Radius of Curvature (r)	0 feet		
Water Surface Width	68.63 feet		
Average Manning's n	0.042		
Flow Depth (Y)	4.12 feet		
Flow Velocity (V)	2.24 feet/second		
D_{75}	4.4 mm	0.17 inches	0.014 feet
D_{65}	3.7 mm	0.15 inches	0.012 feet
D_{50}	0.9 mm	0.04 inches	0.003 feet

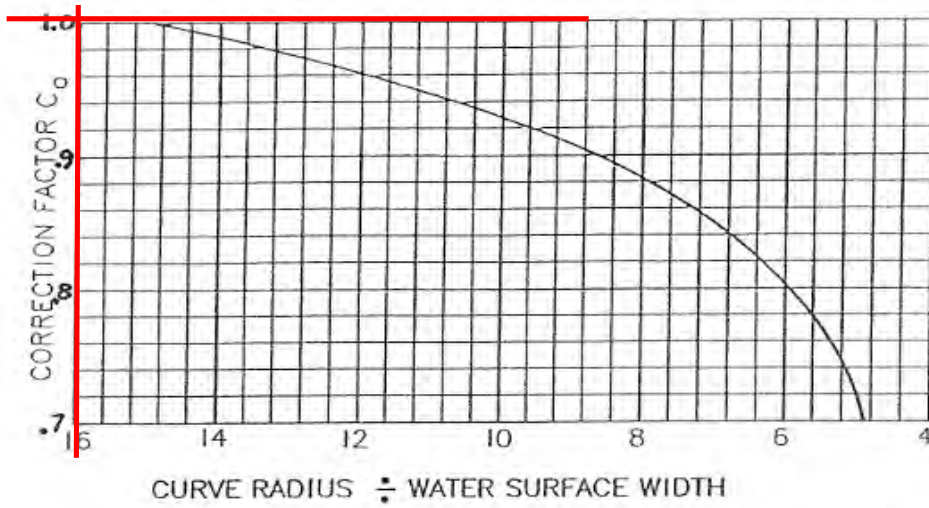
**Allowable Velocity Approach
(Assuming Sediment Laden Flow)**

Base Allowable Velocity for Earth Channels V_b 4.2 feet/sec



Correction Factor C_a For Channel Alignment

1

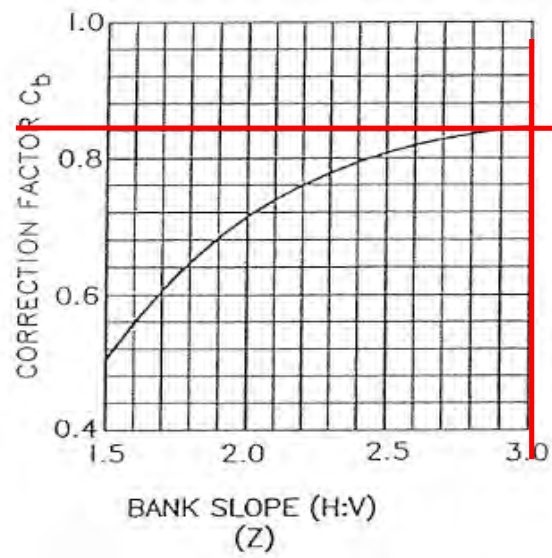


Curve Radius / Water Surface Width

0.0

Correction Factor C_b For Bank Slope

0.84

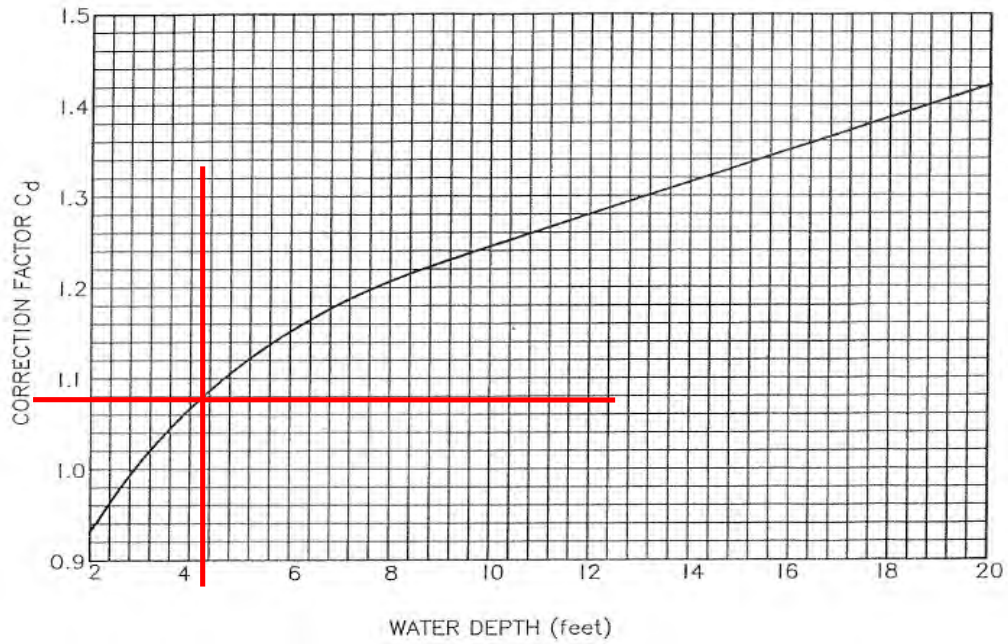


Horizontal/Vertical (Z)

5.33

Correction Factor C_d For Depth of Flow

1.08



Flow Depth (Y)

4.12 feet

Maximum Allowable Velocity

3.81

feet/second

$$V_a = V_b \times C_a \times C_b \times C_d$$

Comparison of Flow Velocity of the Channel to the Maximum Allowable Velocity

Maximum Allowable Velocity

3.81

feet/second

Flow Velocity

2.24

feet/second

Since the computed flow velocity is less than the maximum allowable velocity, erosion is not expected to occur.

Tractive Stress Analysis
(Assuming Sediment Laden Flow)

D_{75} 4.4 mm conversion 0.17 inches

Since D_{75} is less or equal to 0.25 inches, case 2 of reference tractive stress method is used.

Assuming a water temperature of 60°F

Kinematic Velocity (v) 0.0000121 ft² / sec
 Density (ρ) 1.94 slugs/ft³
 Gravity 32.17 ft/sec²

Finding Values Needed for Graphs

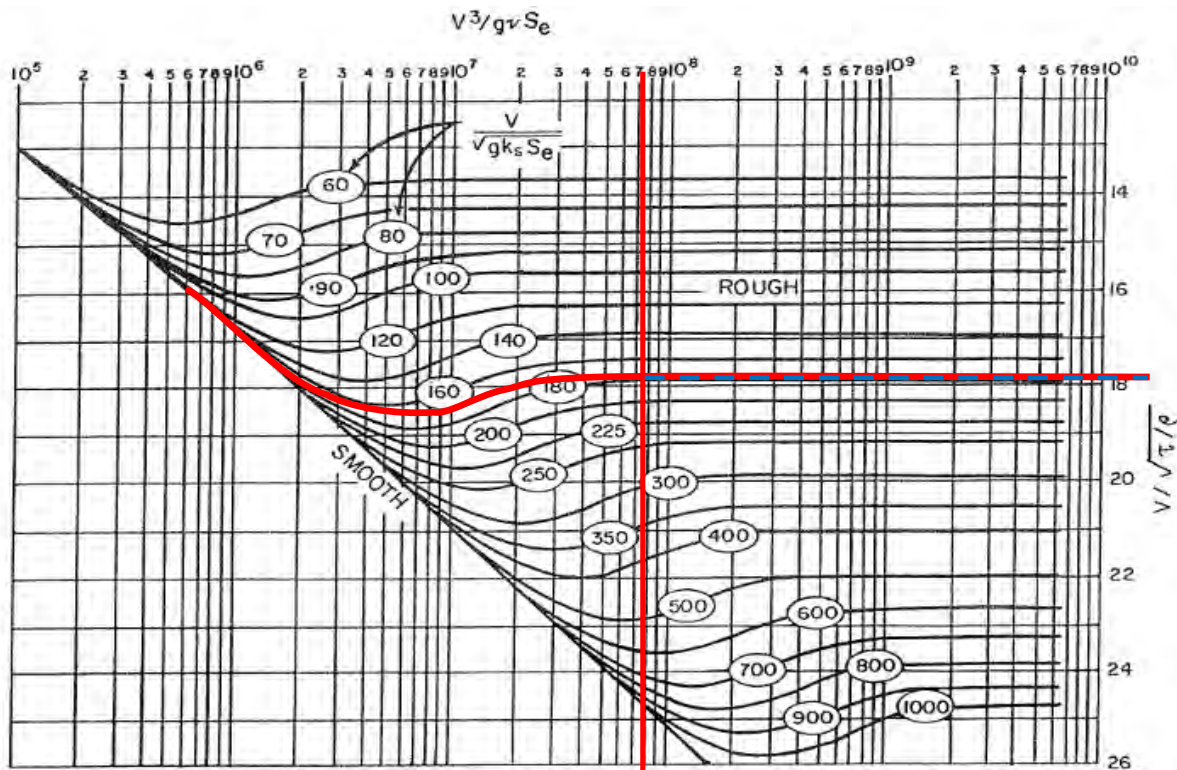
$$V^3 / (g v S_e)$$

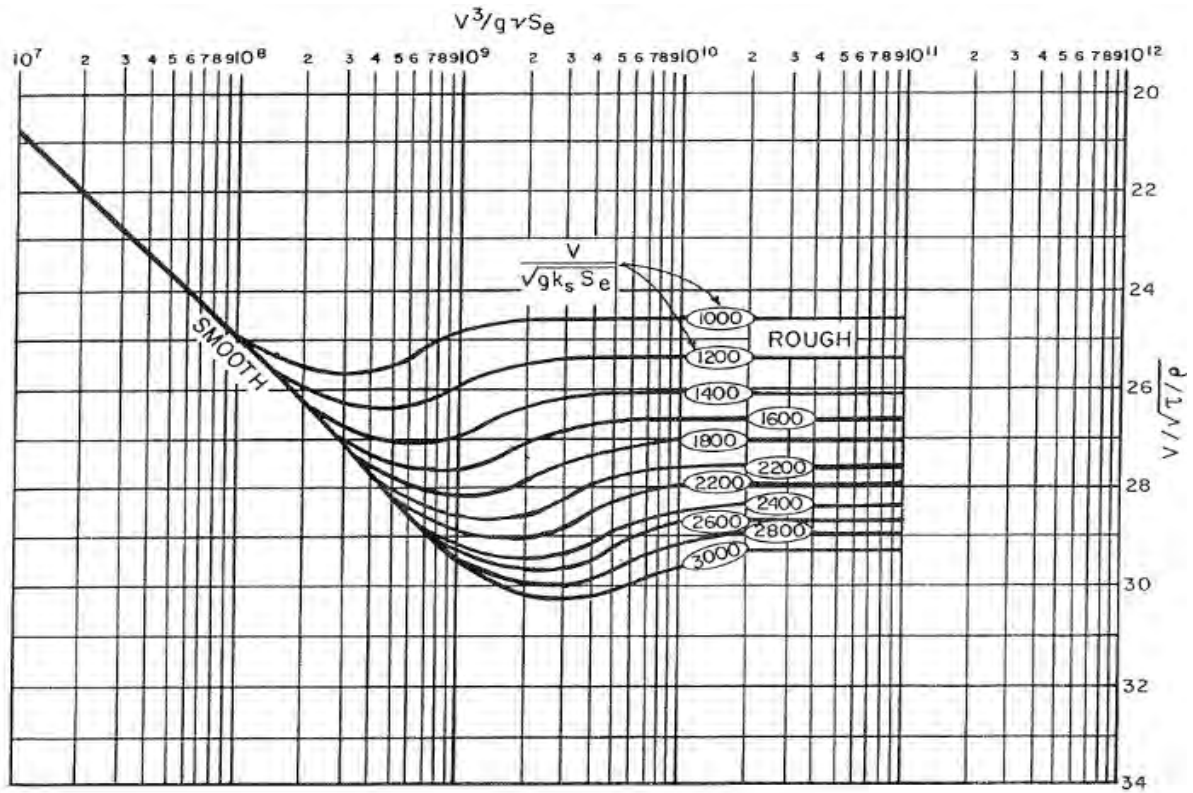
Value 1 7.22E+07

$$V / [(g D_{65} S_e)^{0.5}]$$

Value 2 179.2

Graphic Solution of Reference Tractive Stress



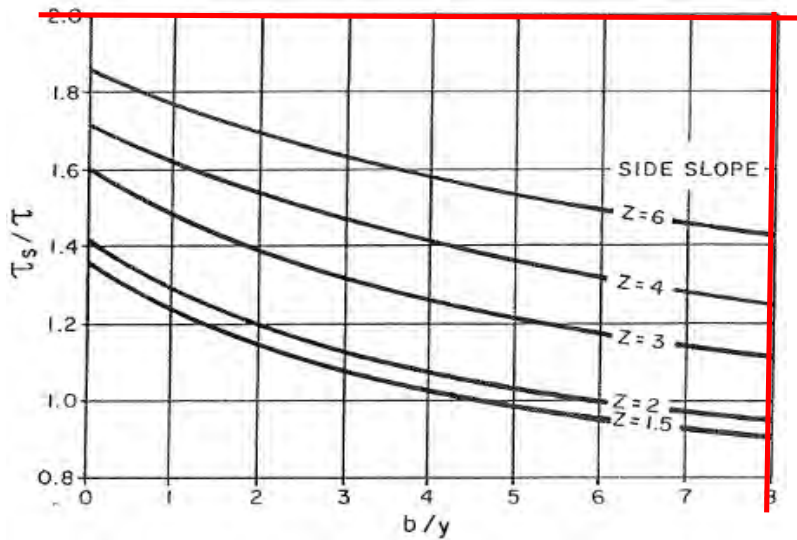


$$V/\sqrt{\tau/\rho}$$

From Graph Above 17.8

Solving the above equation for τ 0.03 lb/ft²

Applied Maximum Tractive Stress, τ_s , on sides of straight trapezoidal channels

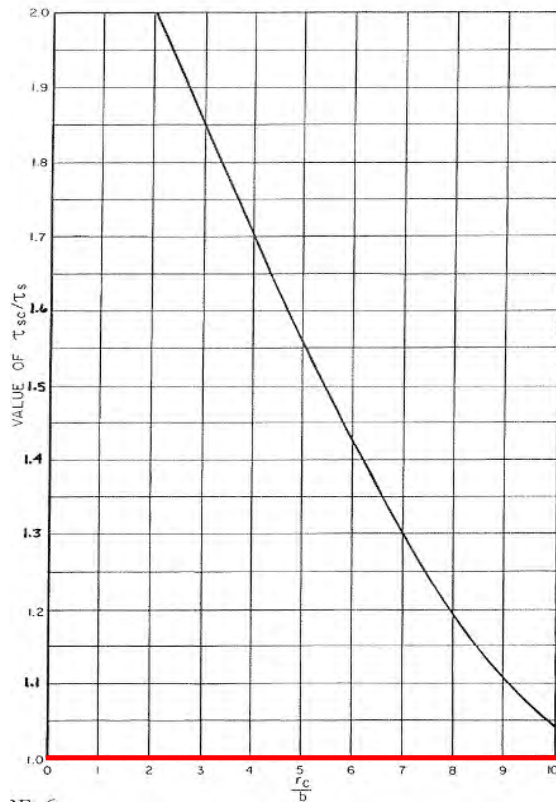


Bottom Width/Flow depth 14.56
Horizontal/Vertical (Z) 5.33

From Graph 2

Solving for τ_s 0.06 lb/ft²

Actual Maximum Tractive Stress, τ_s on sides of trapezoidal channels within a curved reach



Radius of Curvature/Bottom Width

N/A

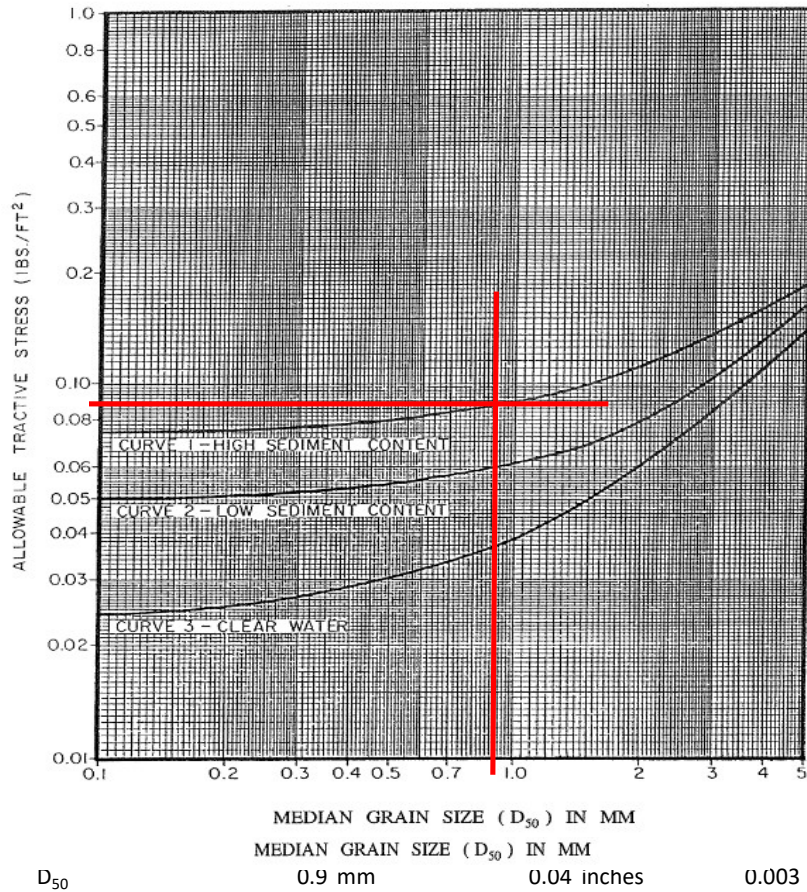
From Graph Above

1.00

Solving for τ_s

0.06 lb/ft²

Maximum Allowable Tractive Stress For Non-Cohesive Soils, $D_{75} < 0.25''$



Allowable Tractive Stress, from graph above 0.092 lb/ft²

Calculated Tractive Stress, τ 0.03 lb/ft²

Since the allowable tractive stress is more than the calculated tractive stress, the channel is not erosive.

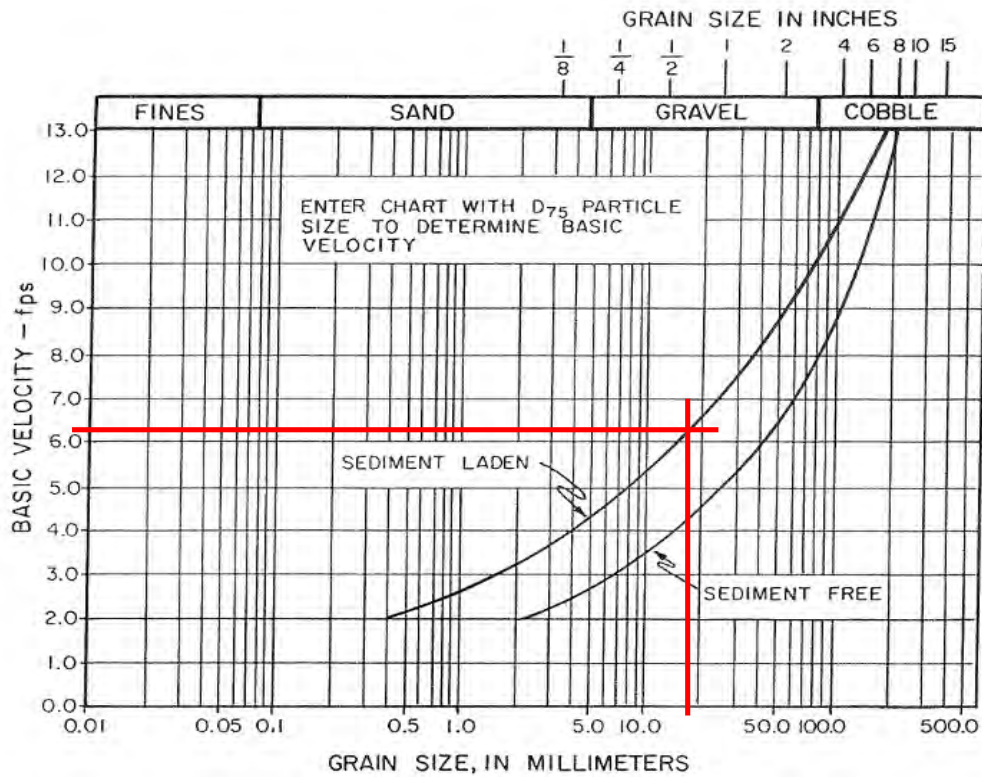
**Lateral Migration Setback Allowance for Riverine Floodplains
Level 2 Analysis**

Cross Section 1193 - General Information

Bottom Width (b)	60 feet		
Side Slope (ft)	22.9 Horizontal	4.3 Vertical	
Channel Slope (S_e)	0.0004 feet/foot		
Radius of Curvature (r)	0 feet		
Water Surface Width	68.63 feet		
Average Manning's n	0.042		
Flow Depth (Y)	4.12 feet		
Flow Velocity (V)	2.24 feet/second		
D_{75}	19 mm	0.75 inches	0.062 feet
D_{65}	9.1 mm	0.36 inches	0.030 feet
D_{50}	5.2 mm	0.20 inches	0.017 feet

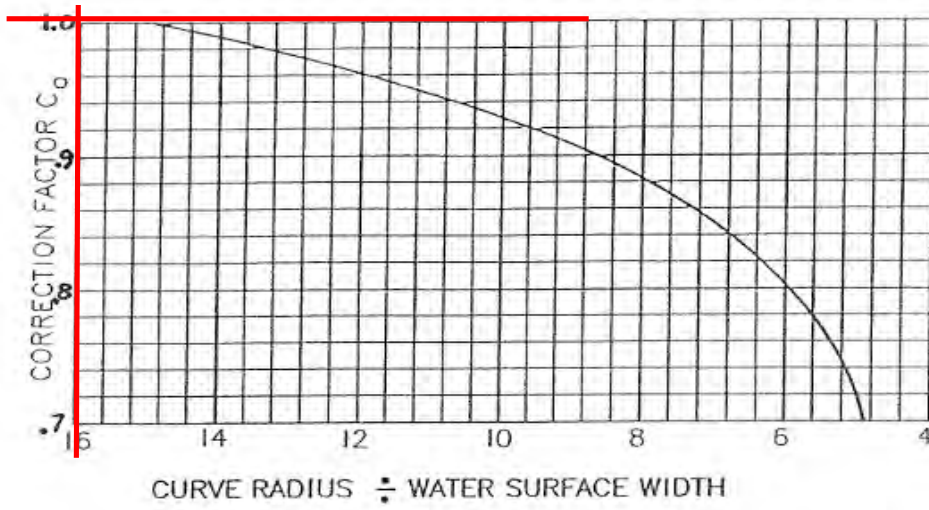
**Allowable Velocity Approach
(Assuming Sediment Laden Flow)**

Base Allowable Velocity for Earth Channels V_b 6.3 feet/sec



Correction Factor C_a For Channel Alignment

1

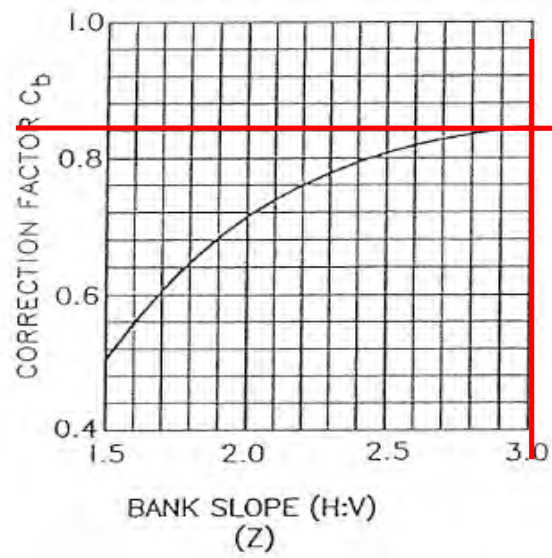


Curve Radius / Water Surface Width

0.0

Correction Factor C_b For Bank Slope

0.84

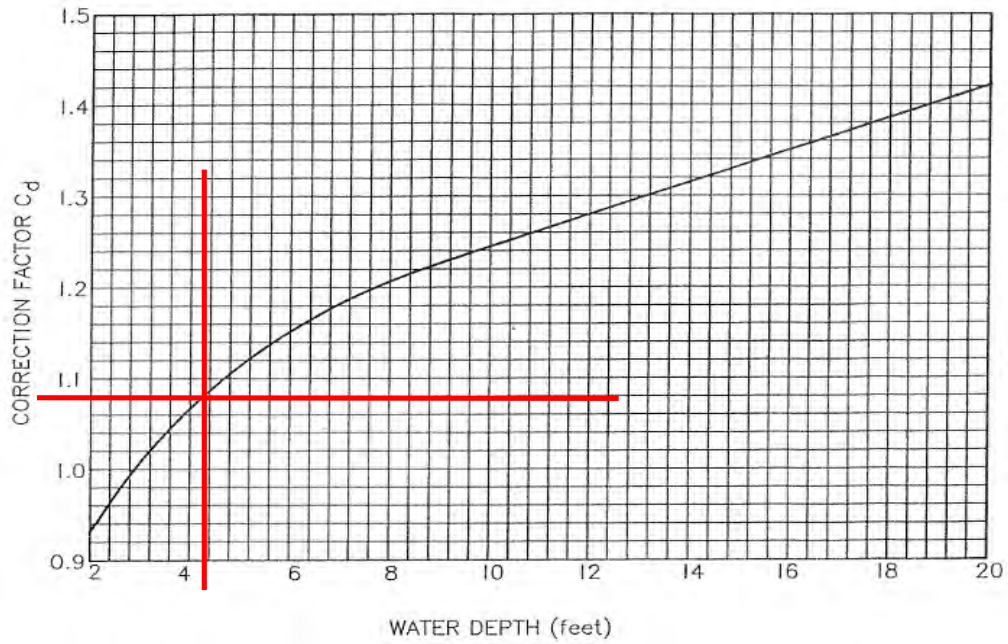


Horizontal/Vertical (Z)

5.33

Correction Factor C_d For Depth of Flow

1.08



Flow Depth (Y)

4.12 feet

Maximum Allowable Velocity

5.72

feet/second

$$V_a = V_b \times C_a \times C_b \times C_d$$

Comparison of Flow Velocity of the Channel to the Maximum Allowable Velocity

Maximum Allowable Velocity

5.72

feet/second

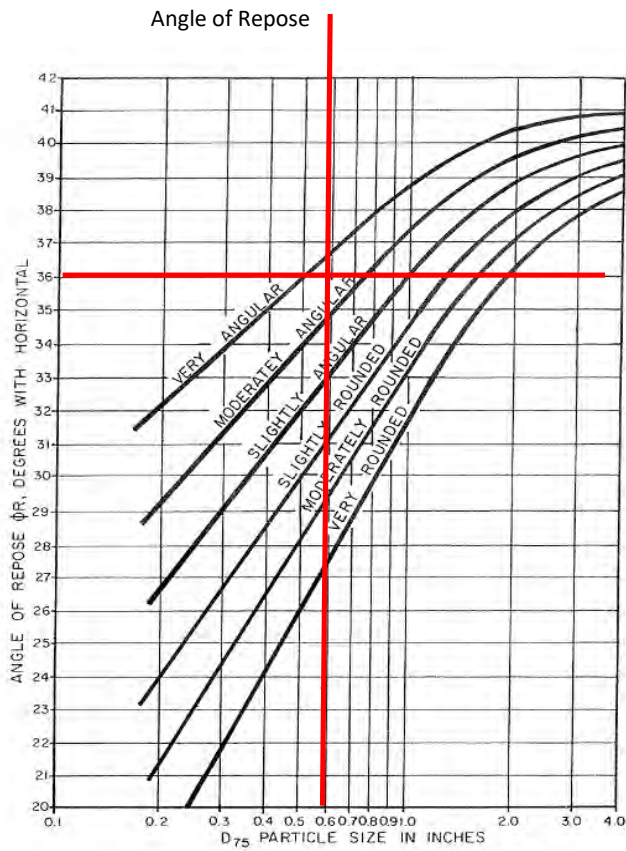
Flow Velocity

2.24

feet/second

Since the computed flow velocity is less than the maximum allowable velocity, erosion is not expected to occur.

Allowable Tractive Stress (τ_s)



Moderately Angular
 D_{75} 0.75 inches
 From Chart (ϕR) 36 Degrees

Solving for Allowable Tractive Stress

$$0.4 \left[\frac{Z^2 - \text{Cot}^2 \phi R}{1 + Z^2} \right]^{\frac{1}{2}} D_{75}$$

0.279 lbs/ft²

Allowable Tractive Stress, from calculation above 0.279 lb/ft²

Calculated Tractive Stress, τ 0.012 lb/ft²

Since the allowable tractive stress is more than the calculated tractive stress, the channel is not erosive.

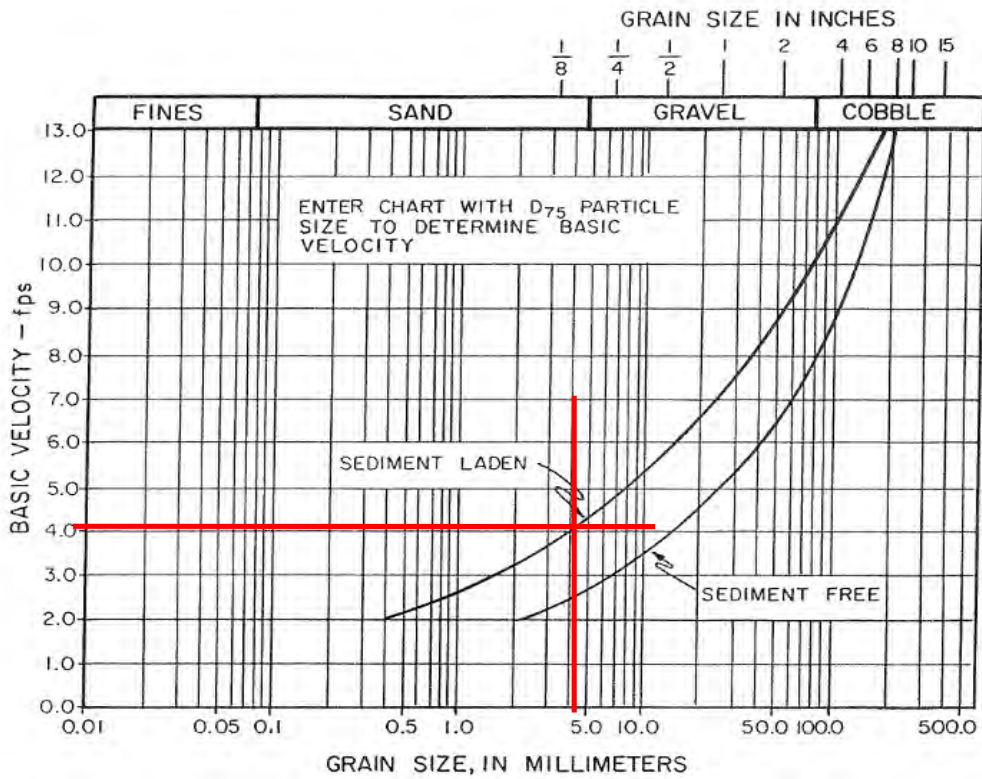
**Lateral Migration Setback Allowance for Riverine Floodplains
Level 2 Analysis**

Cross Section 1223 - General Information

Bottom Width (b)	35.9 feet		
Side Slope (ft)	30 Horizontal	3.7 Vertical	
Channel Slope (S_e)	0.001 feet/foot		
Radius of Curvature (r)	0 feet		
Water Surface Width	66.29 feet		
Average Manning's n	0.042		
Flow Depth (Y)	3.93 feet		
Flow Velocity (V)	2.99 feet/second		
D_{75}	4.4 mm	0.17 inches	0.014 feet
D_{65}	3.7 mm	0.15 inches	0.012 feet
D_{50}	0.9 mm	0.04 inches	0.003 feet

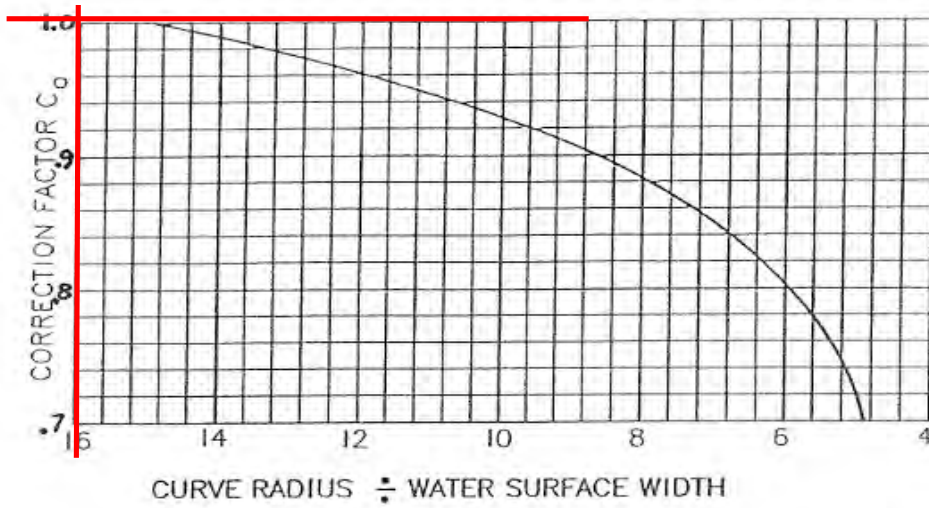
**Allowable Velocity Approach
(Assuming Sediment Laden Flow)**

Base Allowable Velocity for Earth Channels V_b 4.2 feet/sec



Correction Factor C_a For Channel Alignment

1

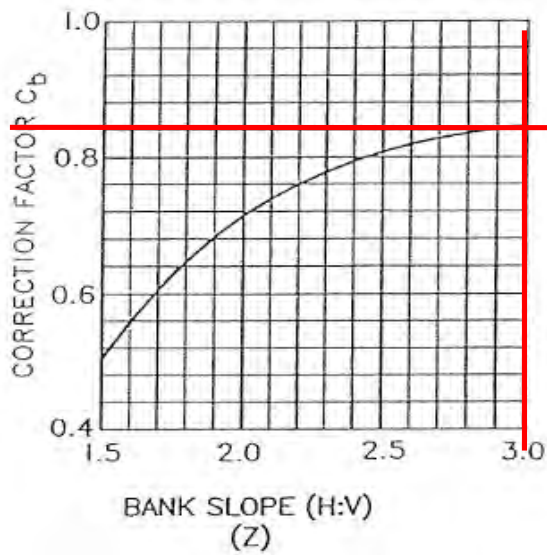


Curve Radius / Water Surface Width

0.0

Correction Factor C_b For Bank Slope

0.84

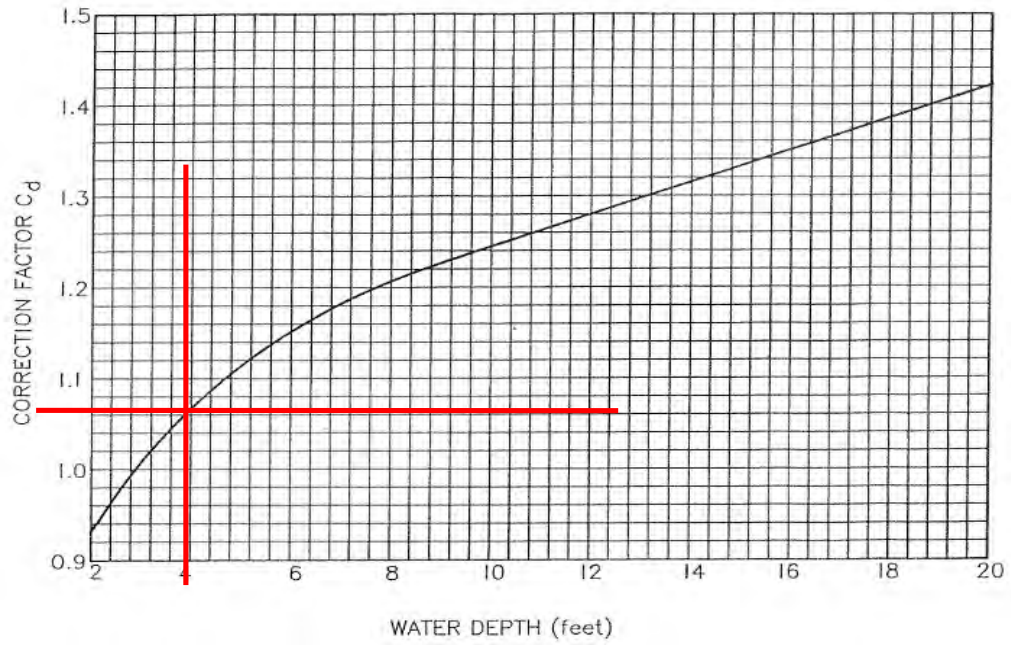


Horizontal/Vertical (Z)

8.11

Correction Factor C_d For Depth of Flow

1.06



Flow Depth (Y)

3.93 feet

Maximum Allowable Velocity

3.74

feet/second

$$V_a = V_b \times C_a \times C_b \times C_d$$

Comparison of Flow Velocity of the Channel to the Maximum Allowable Velocity

Maximum Allowable Velocity

3.74

feet/second

Flow Velocity

2.99

feet/second

Since the computed flow velocity is less than the maximum allowable velocity, erosion is not expected to occur.

**Tractive Stress Analysis
(Assuming Sediment Laden Flow)**

D_{75} 4.4 mm conversion 0.17 inches

Since D_{75} is less or equal to 0.25 inches, case 2 of reference tractive stress method is used.

Assuming a water temperature of 60°F

Kinematic Velocity (v) 0.0000121 ft² / sec
 Density (ρ) 1.94 slugs/ft³
 Gravity 32.17 ft/sec²

Finding Values Needed for Graphs

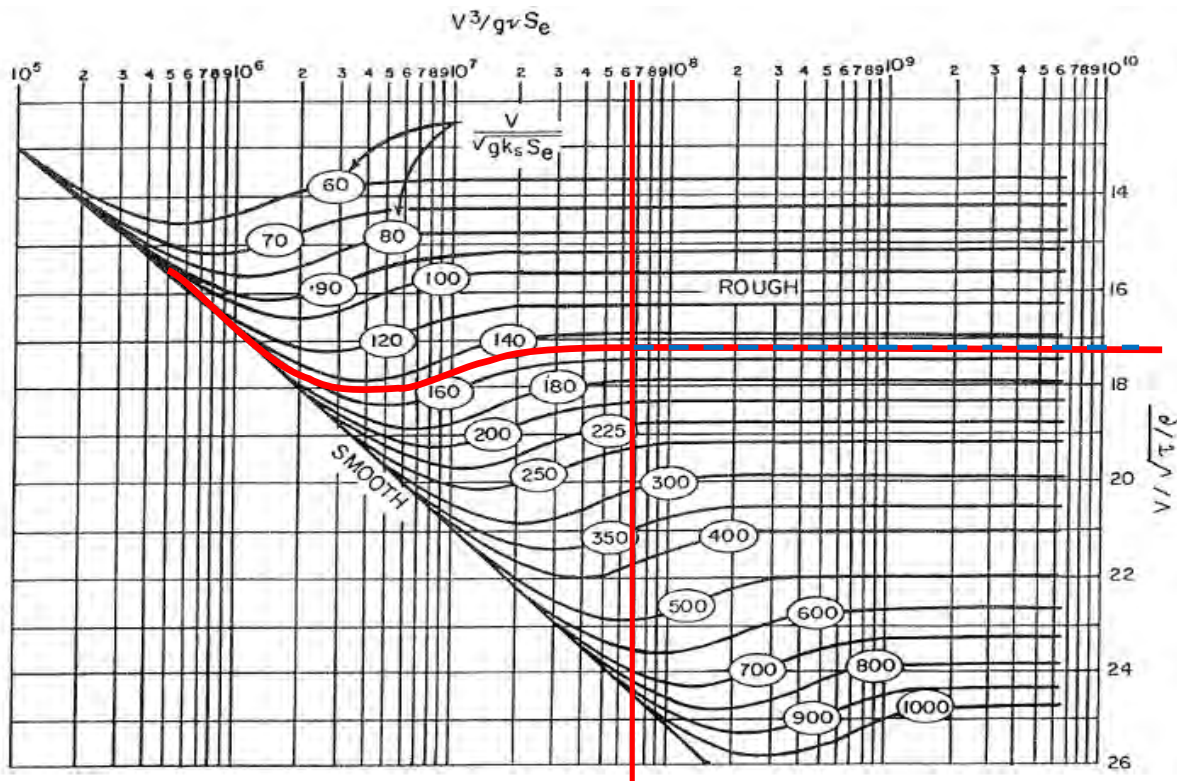
$$V^3 / (g v S_e)$$

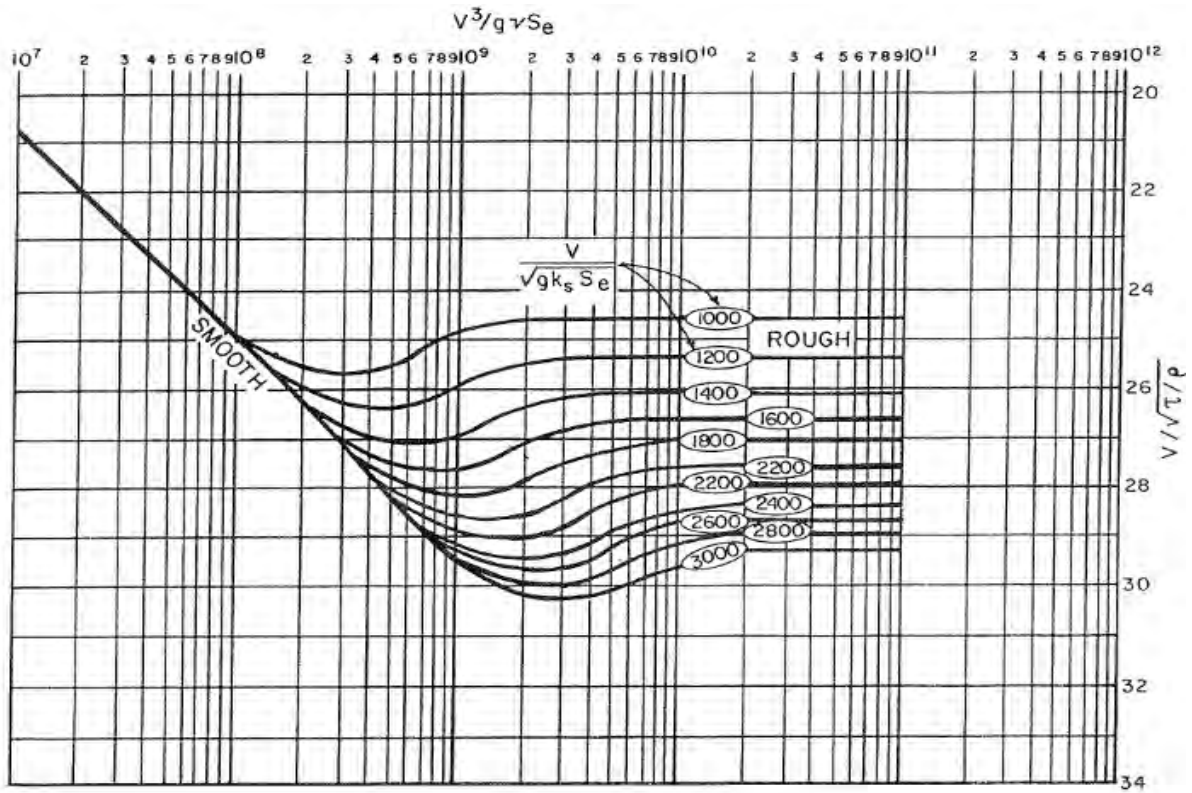
Value 1 6.87E+07

$$V / [(g D_{65} S_e)^{0.5}]$$

Value 2 151.3

Graphic Solution of Reference Tractive Stress



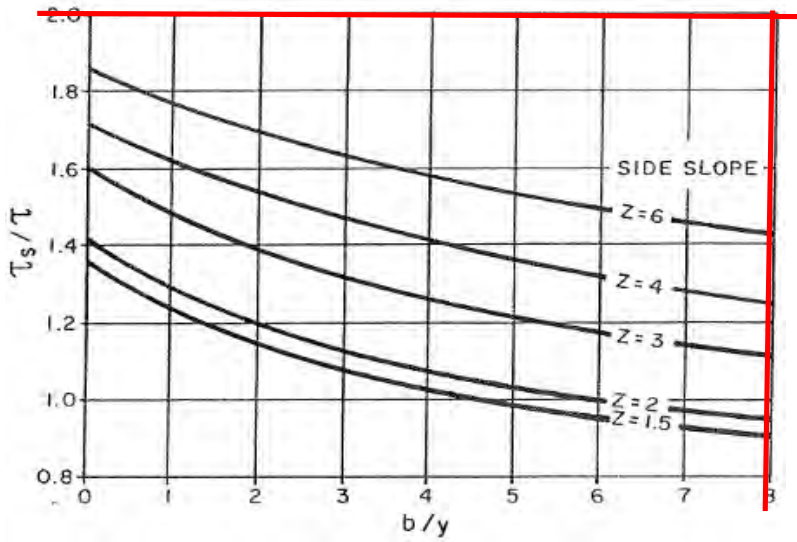


$$V/\sqrt{\tau/\rho}$$

From Graph Above 17.3

Solving the above equation for τ 0.06 lb/ft²

Applied Maximum Tractive Stress, τ_s , on sides of straight trapezoidal channels

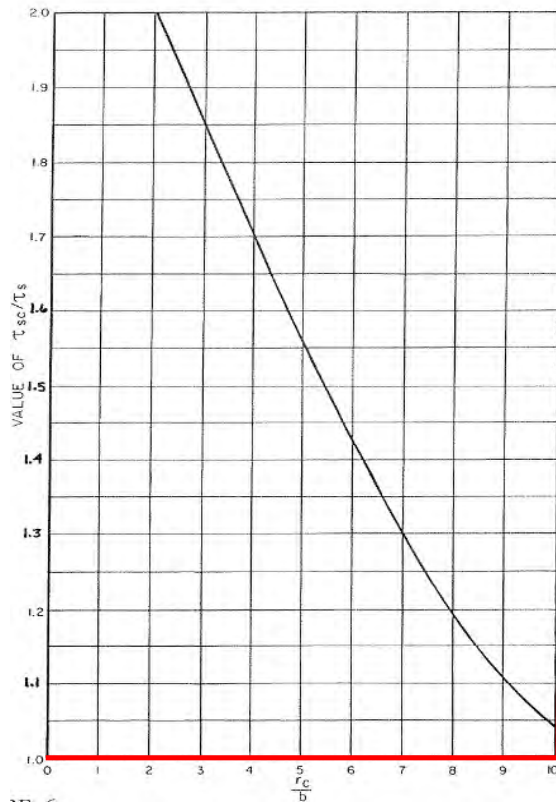


Bottom Width/Flow depth 9.13
Horizontal/Vertical (Z) 8.11

From Graph 2

Solving for τ_s 0.12 lb/ft²

Actual Maximum Tractive Stress, τ_s on sides of trapezoidal channels within a curved reach



Radius of Curvature/Bottom Width

N/A

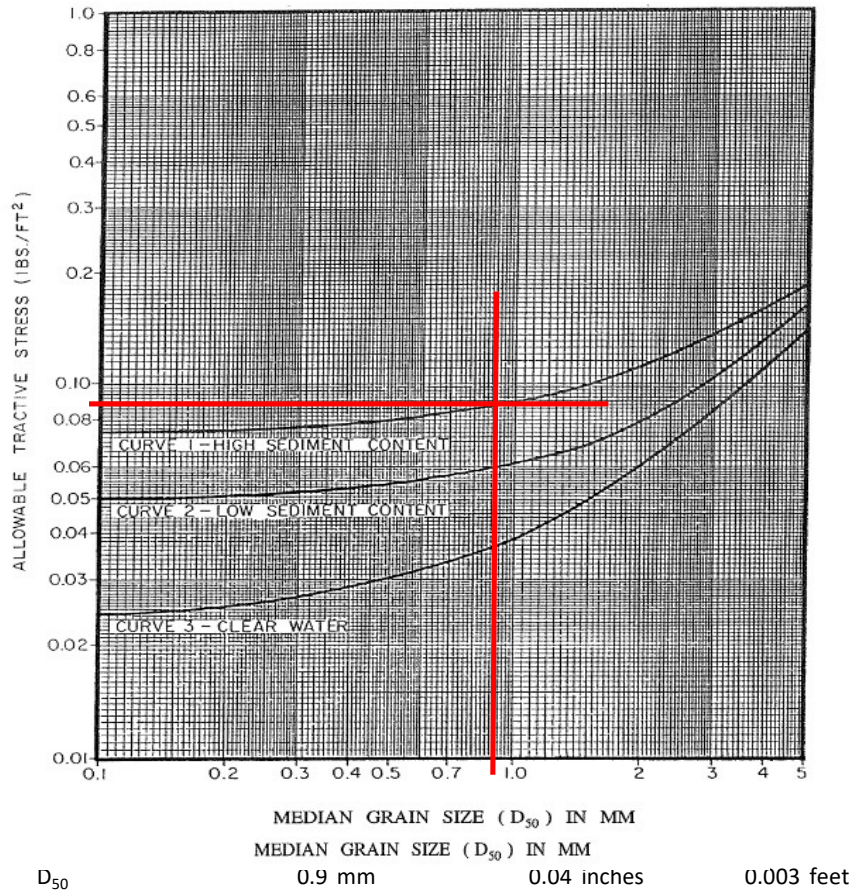
From Graph Above

1.00

Solving for τ_s

0.12 lb/ft²

Maximum Allowable Tractive Stress For Non-Cohesive Soils, $D_{75} < 0.25''$



Allowable Tractive Stress, from graph above 0.092 lb/ft²

Calculated Tractive Stress, τ 0.06 lb/ft²

Since the allowable tractive stress is more than the calculated tractive stress, the channel is not erosive.

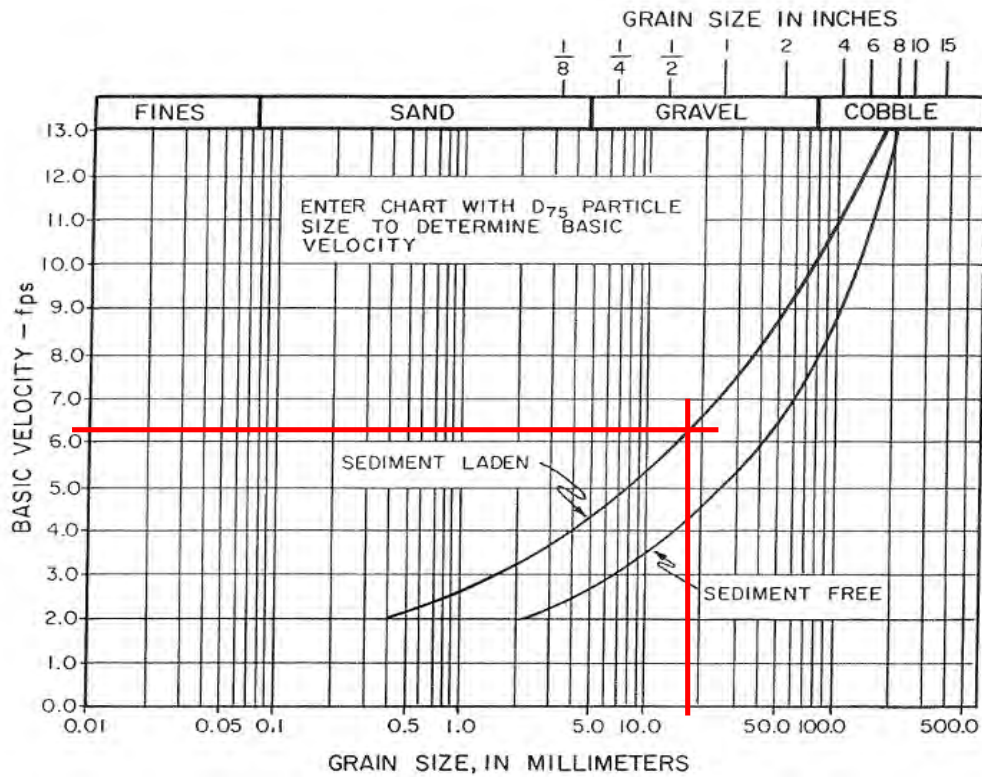
**Lateral Migration Setback Allowance for Riverine Floodplains
Level 2 Analysis**

Cross Section 1223 - General Information

Bottom Width (b)	35.9 feet		
Side Slope (ft)	30 Horizontal	3.7 Vertical	
Channel Slope (S _e)	0.001 feet/foot		
Radius of Curvature (r)	0 feet		
Water Surface Width	66.29 feet		
Average Manning's n	0.042		
Flow Depth (Y)	3.93 feet		
Flow Velocity (V)	2.99 feet/second		
D ₇₅	19 mm	0.75 inches	0.062 feet
D ₆₅	9.1 mm	0.36 inches	0.030 feet
D ₅₀	5.2 mm	0.20 inches	0.017 feet

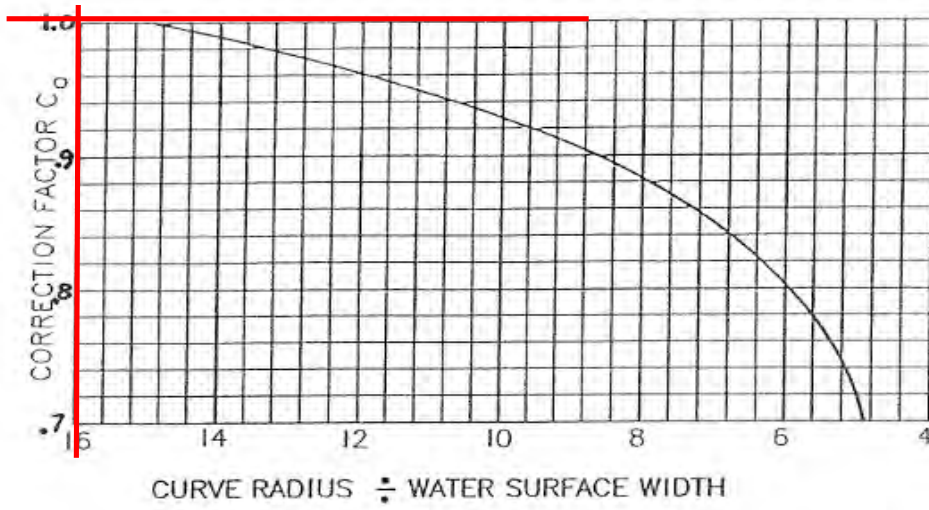
**Allowable Velocity Approach
(Assuming Sediment Laden Flow)**

Base Allowable Velocity for Earth Channels V_b 6.3 feet/sec



Correction Factor C_a For Channel Alignment

1

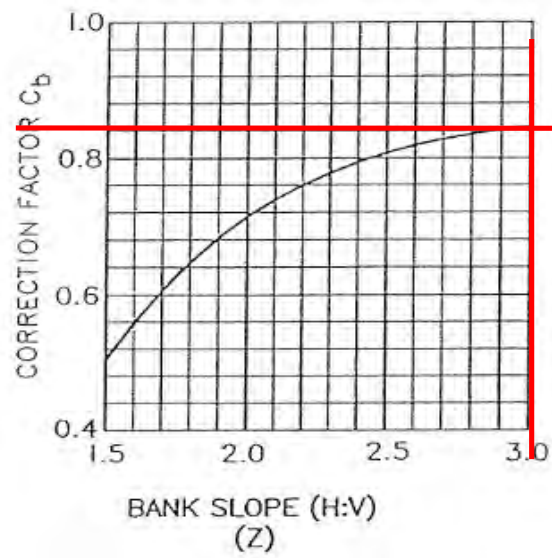


Curve Radius / Water Surface Width

0.0

Correction Factor C_b For Bank Slope

0.84

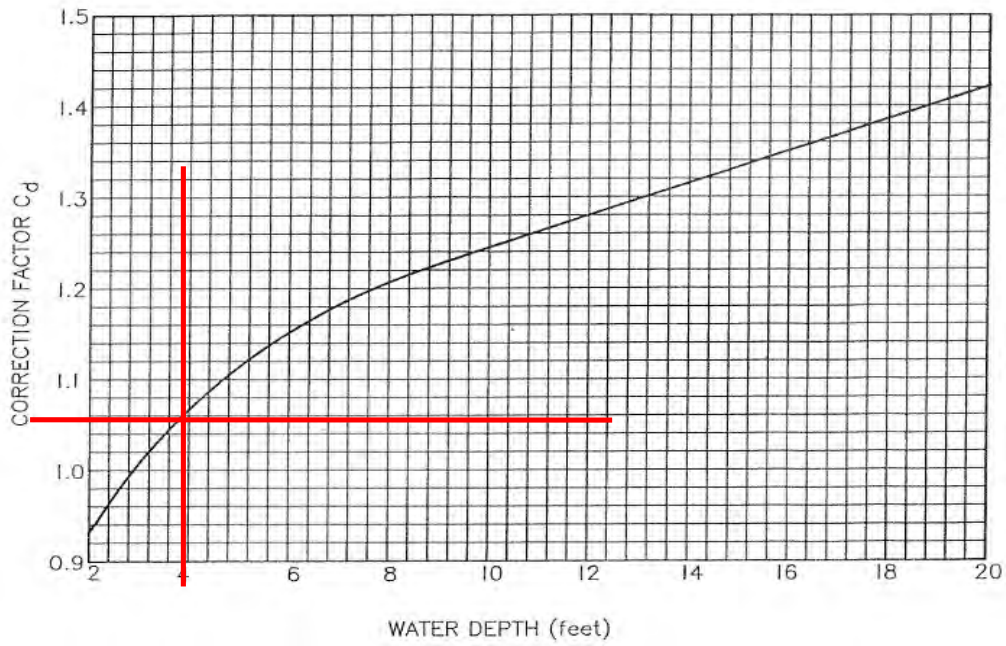


Horizontal/Vertical (Z)

8.11

Correction Factor C_d For Depth of Flow

1.06



Flow Depth (Y)

3.93 feet

Maximum Allowable Velocity

5.61

feet/second

$$V_a = V_b \times C_a \times C_b \times C_d$$

Comparison of Flow Velocity of the Channel to the Maximum Allowable Velocity

Maximum Allowable Velocity

5.61

feet/second

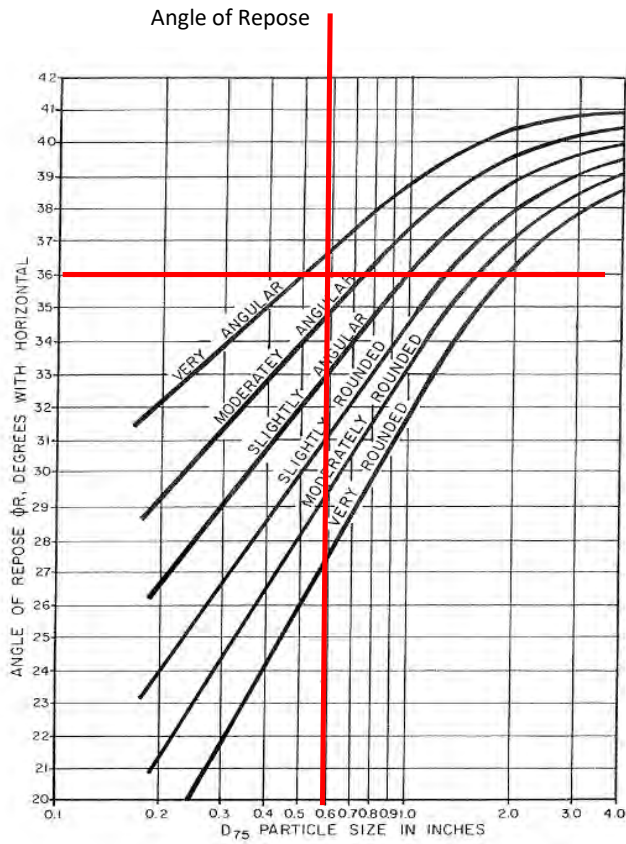
Flow Velocity

2.99

feet/second

Since the computed flow velocity is less than the maximum allowable velocity, erosion is not expected to occur.

Allowable Tractive Stress (τ_{ls})



Moderately Angular
 D_{75} 0.75 inches
 From Chart (ϕ_R) 36 Degrees

Solving for Allowable Tractive Stress

$$0.4 \left[\frac{Z^2 - \text{Cot}^2 \phi_R}{1 + Z^2} \right]^{\frac{1}{2}} D_{75}$$

0.290 lbs/ft²

Allowable Tractive Stress, from calculation above 0.290 lb/ft²

Calculated Tractive Stress, τ 0.029 lb/ft²

Since the allowable tractive stress is more than the calculated tractive stress, the channel is not erosive.

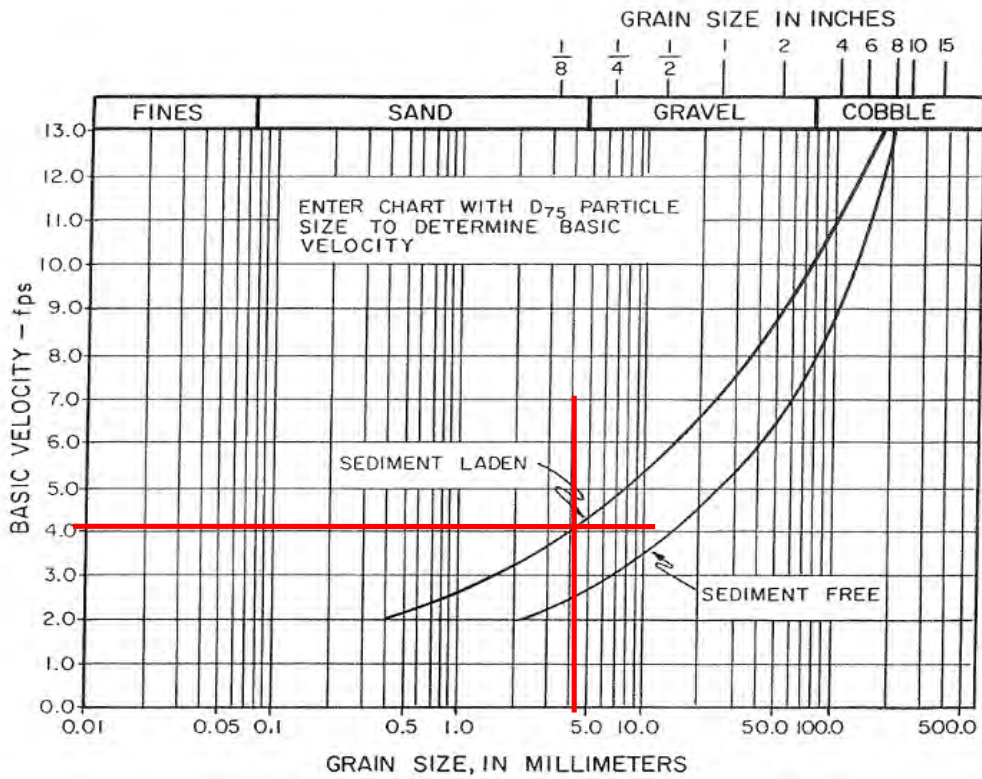
**Lateral Migration Setback Allowance for Riverine Floodplains
Level 2 Analysis**

Cross Section 1319 - General Information

Bottom Width (b)	37 feet		
Side Slope (ft)	23.5 Horizontal	4.25 Vertical	
Channel Slope (S_e)	0.003 feet/foot		
Radius of Curvature (r)	0 feet		
Water Surface Width	55.14 feet		
Average Manning's n	0.042		
Flow Depth (Y)	3.70 feet		
Flow Velocity (V)	3.81 feet/second		
D_{75}	4.4 mm	0.17 inches	0.014 feet
D_{65}	3.7 mm	0.15 inches	0.012 feet
D_{50}	0.9 mm	0.04 inches	0.003 feet

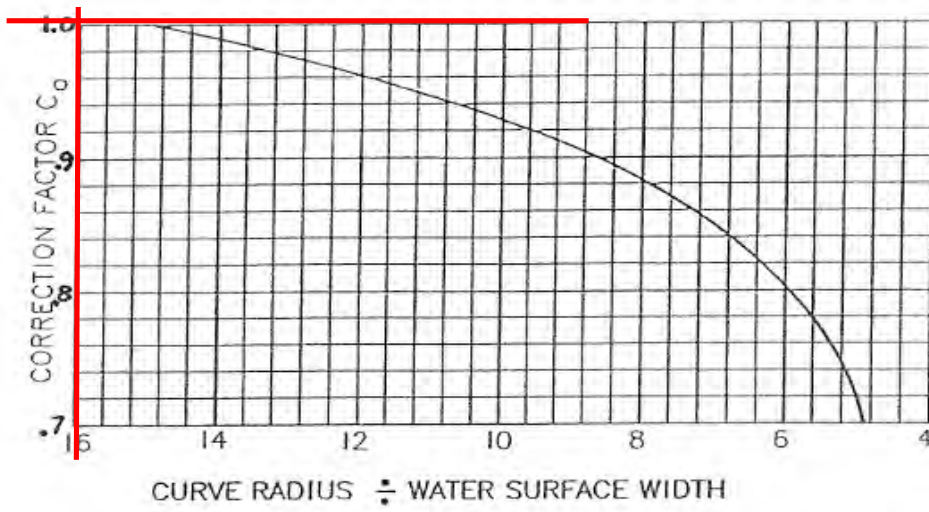
**Allowable Velocity Approach
(Assuming Sediment Laden Flow)**

Base Allowable Velocity for Earth Channels V_b 4.2 feet/sec



Correction Factor C_a For Channel Alignment

1

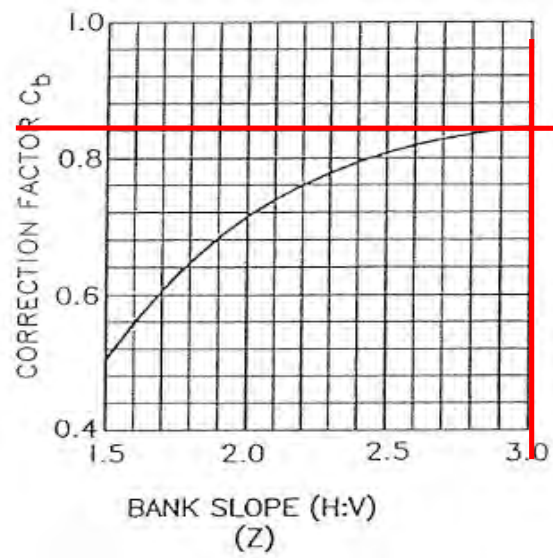


Curve Radius / Water Surface Width

0.0

Correction Factor C_b For Bank Slope

0.84

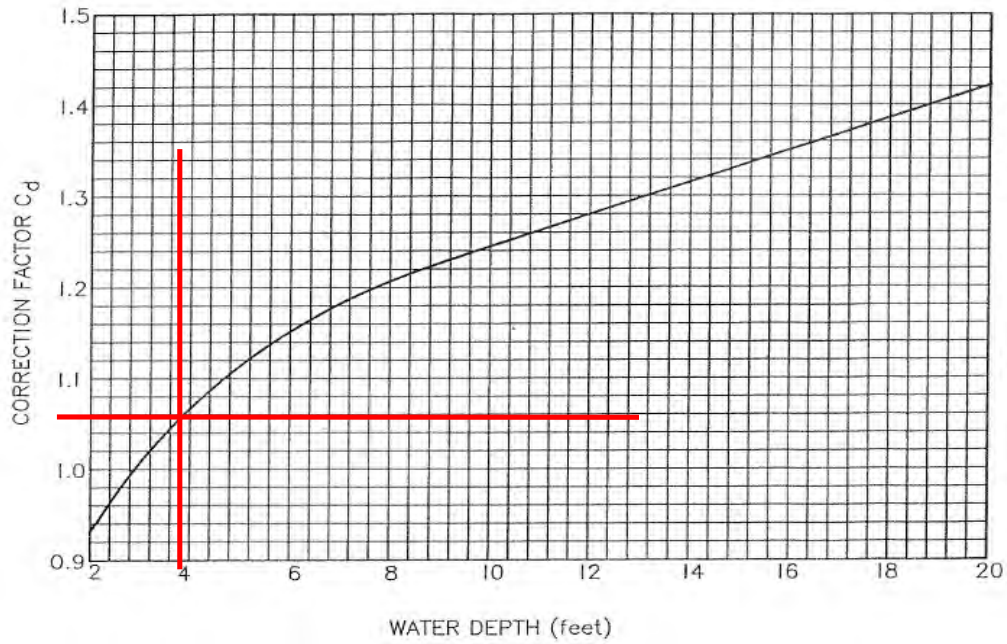


Horizontal/Vertical (Z)

5.53

Correction Factor C_d For Depth of Flow

1.06



Flow Depth (Y)

3.7 feet

Maximum Allowable Velocity

3.74

feet/second

$$V_a = V_b \times C_a \times C_b \times C_d$$

Comparison of Flow Velocity of the Channel to the Maximum Allowable Velocity

Maximum Allowable Velocity

3.74

feet/second

Flow Velocity

3.81

feet/second

Since the computed flow velocity exceeds the maximum allowable velocity, erosion may be expected to occur

Tractive Stress Analysis
(Assuming Sediment Laden Flow)

D_{75} 4.4 mm conversion 0.17 inches

Since D_{75} is less or equal to 0.25 inches, case 2 of reference tractive stress method is used.

Assuming a water temperature of 60°F

Kinematic Velocity (ν) 0.0000121 ft² / sec
 Density (ρ) 1.94 slugs/ft³
 Gravity 32.17 ft/sec²

Finding Values Needed for Graphs

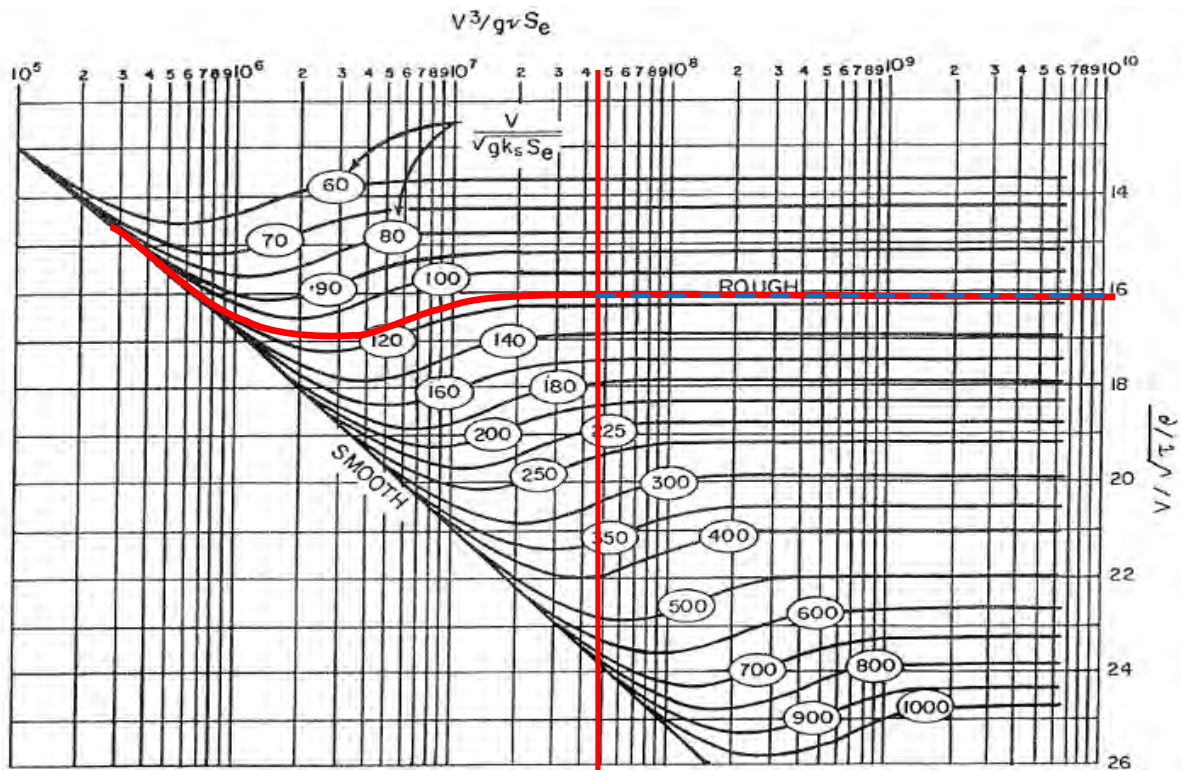
$$V^3 / (g\nu S_e)$$

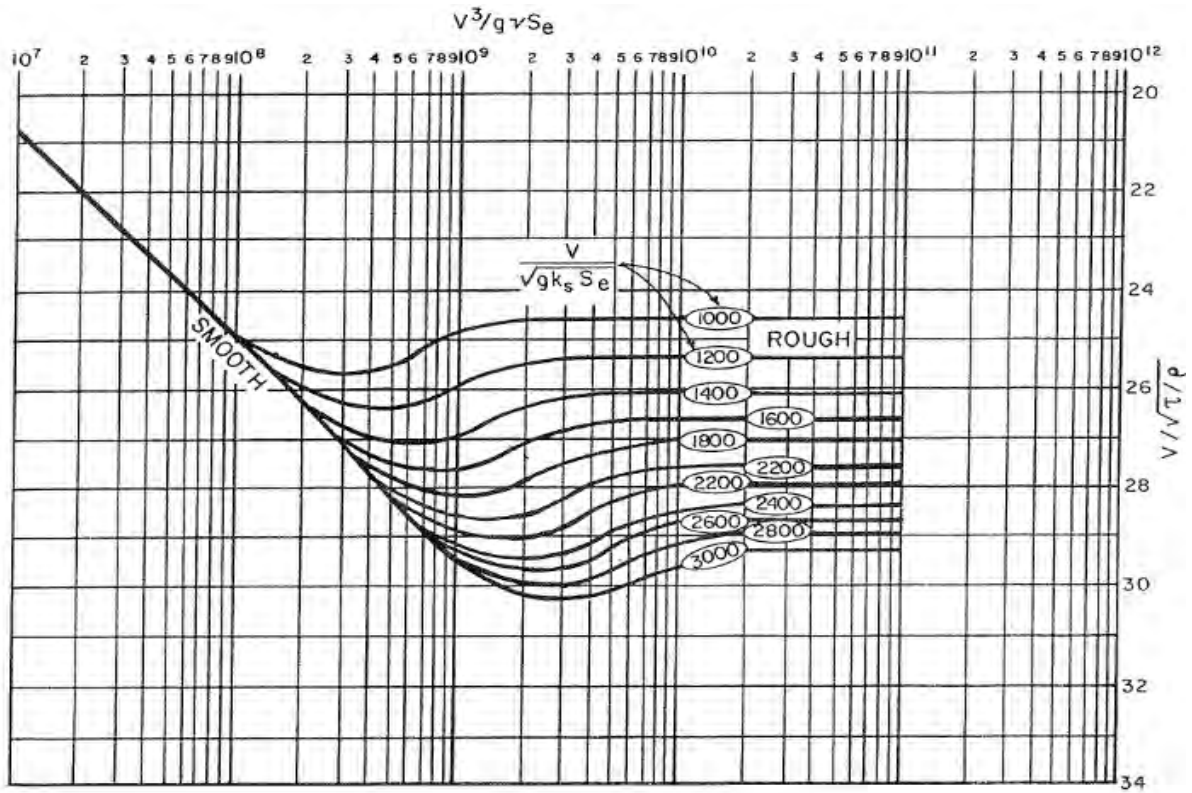
Value 1 4.74E+07

$$V / [(gD_{65} S_e)^{0.5}]$$

Value 2 111.3

Graphic Solution of Reference Tractive Stress



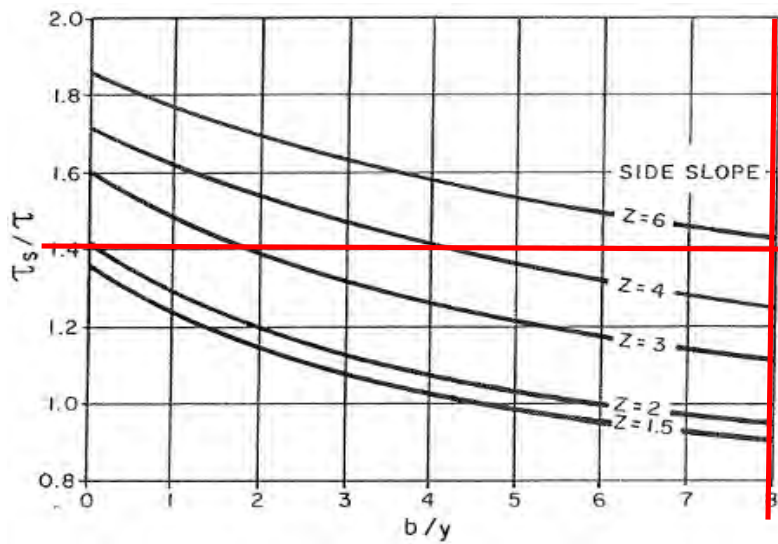


$$V/\sqrt{\tau/\rho}$$

From Graph Above 16.1

Solving the above equation for τ 0.11 lb/ft²

Applied Maximum Tractive Stress, τ_s , on sides of straight trapezoidal channels

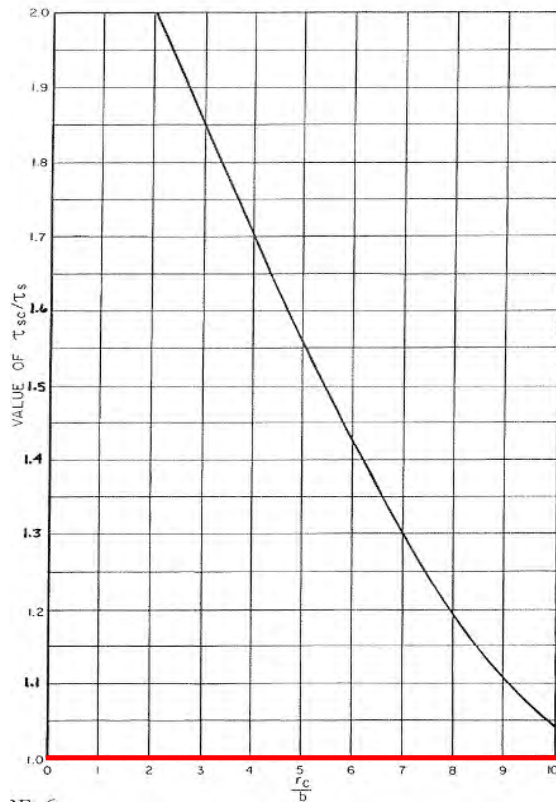


Bottom Width/Flow depth 10.00
Horizontal/Vertical (Z) 5.53

From Graph 1.4

Solving for τ_s 0.15 lb/ft²

Actual Maximum Tractive Stress, τ_s on sides of trapezoidal channels within a curved reach



Radius of Curvature/Bottom Width

N/A

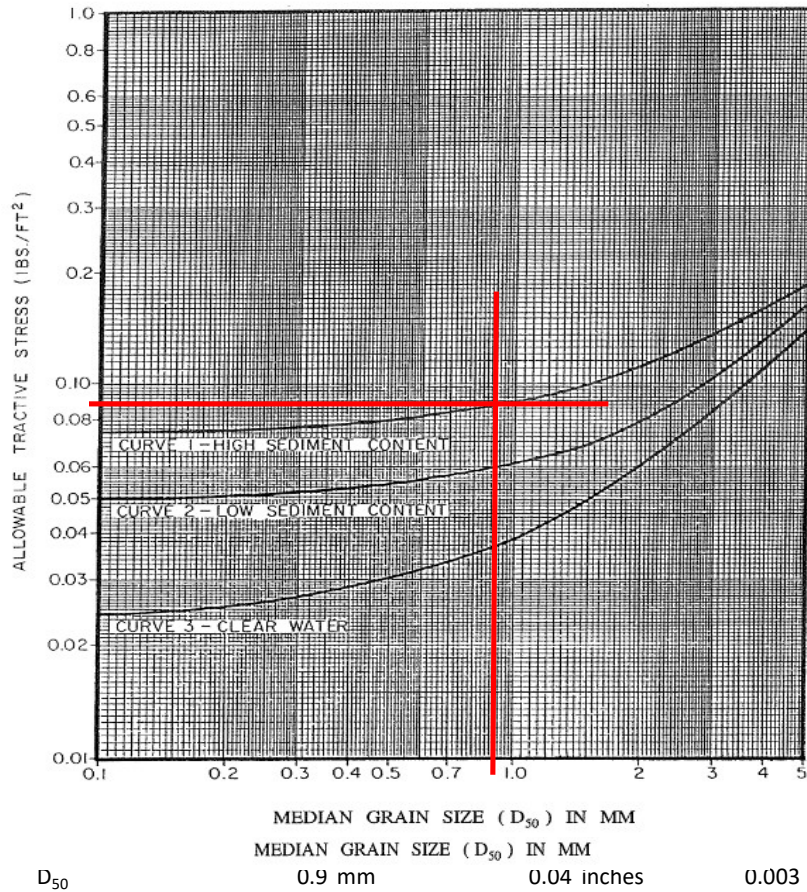
From Graph Above

1.00

Solving for τ_s

0.15 lb/ft²

Maximum Allowable Tractive Stress For Non-Cohesive Soils, $D_{75} < 0.25''$



Allowable Tractive Stress, from graph above 0.092 lb/ft²

Calculated Tractive Stress, τ 0.109 lb/ft²

Since the allowable tractive stress is less than the calculated tractive stress, the channel is erosive.

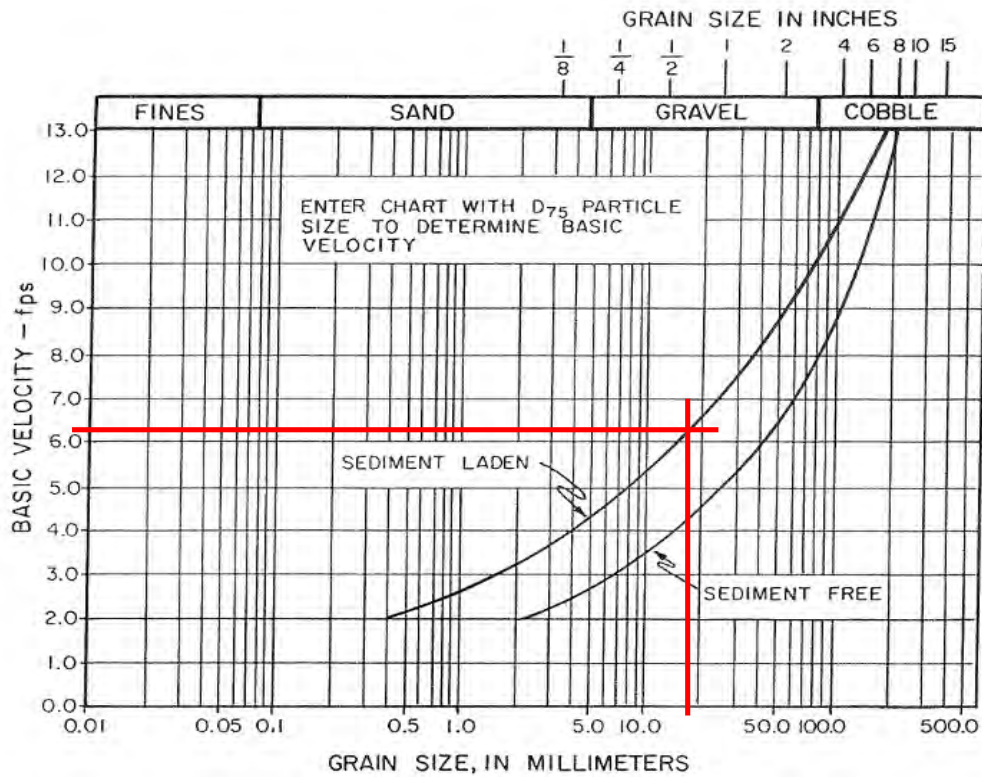
**Lateral Migration Setback Allowance for Riverine Floodplains
Level 2 Analysis**

Cross Section 1319 - General Information

Bottom Width (b)	37 feet		
Side Slope (ft)	23.5 Horizontal	4.25 Vertical	
Channel Slope (S_e)	0.003 feet/foot		
Radius of Curvature (r)	0 feet		
Water Surface Width	55.14 feet		
Average Manning's n	0.042		
Flow Depth (Y)	3.70 feet		
Flow Velocity (V)	3.81 feet/second		
D_{75}	19 mm	0.75 inches	0.062 feet
D_{65}	9.1 mm	0.36 inches	0.030 feet
D_{50}	5.2 mm	0.20 inches	0.017 feet

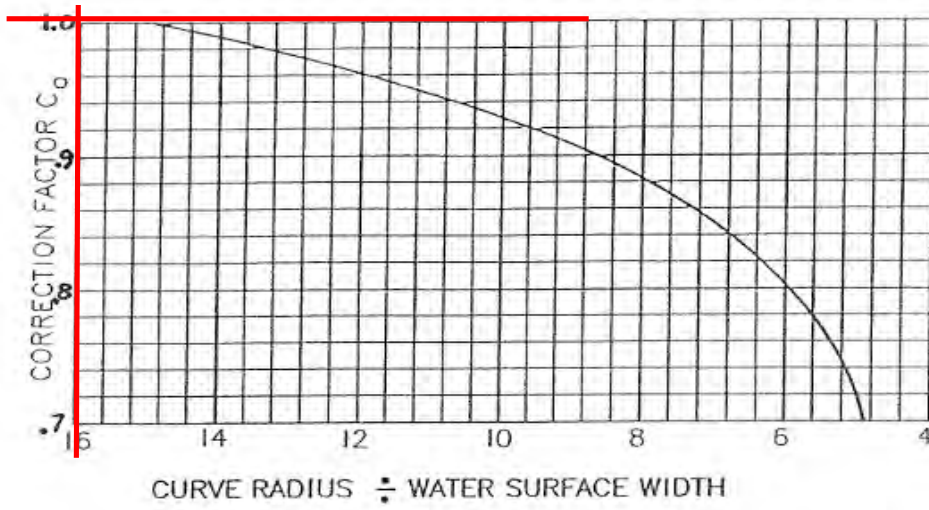
**Allowable Velocity Approach
(Assuming Sediment Laden Flow)**

Base Allowable Velocity for Earth Channels V_b 6.3 feet/sec



Correction Factor C_a For Channel Alignment

1

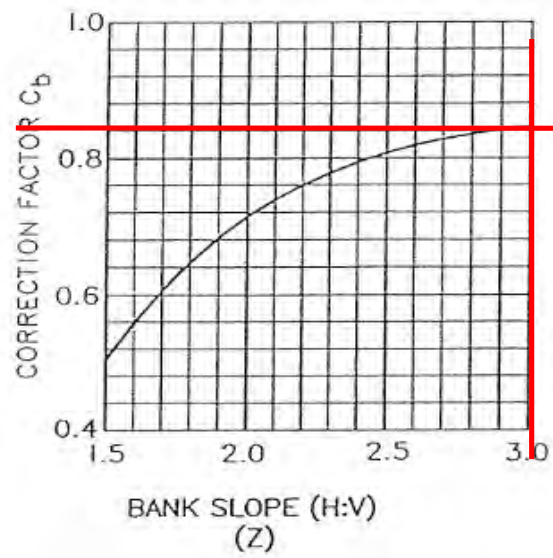


Curve Radius / Water Surface Width

0.0

Correction Factor C_b For Bank Slope

0.84

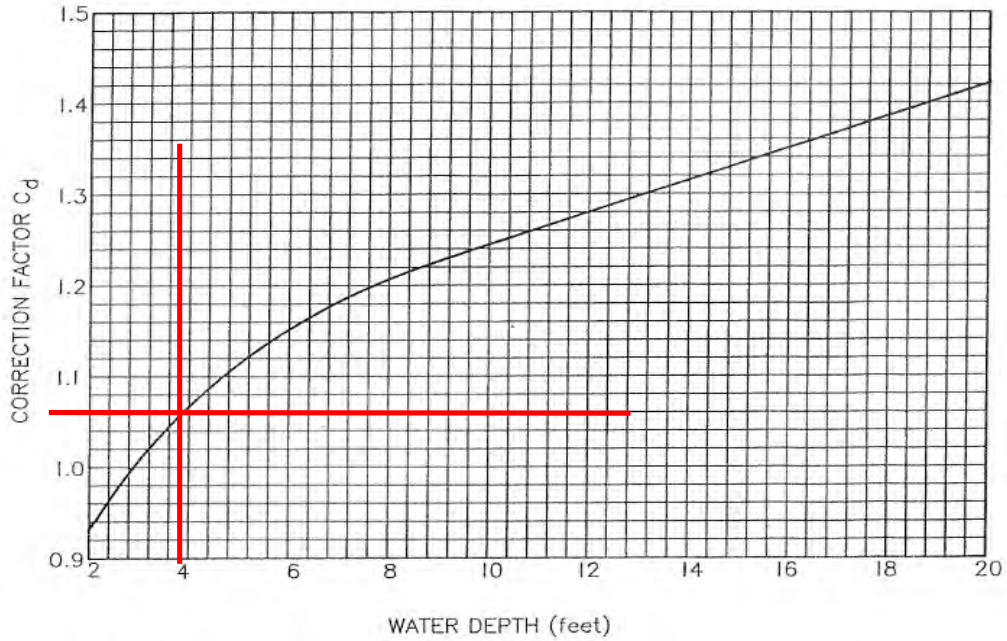


Horizontal/Vertical (Z)

5.53

Correction Factor C_d For Depth of Flow

1.06



Flow Depth (Y)

3.7 feet

Maximum Allowable Velocity

5.61

feet/second

$$V_a = V_b \times C_a \times C_b \times C_d$$

Comparison of Flow Velocity of the Channel to the Maximum Allowable Velocity

Maximum Allowable Velocity

5.61

feet/second

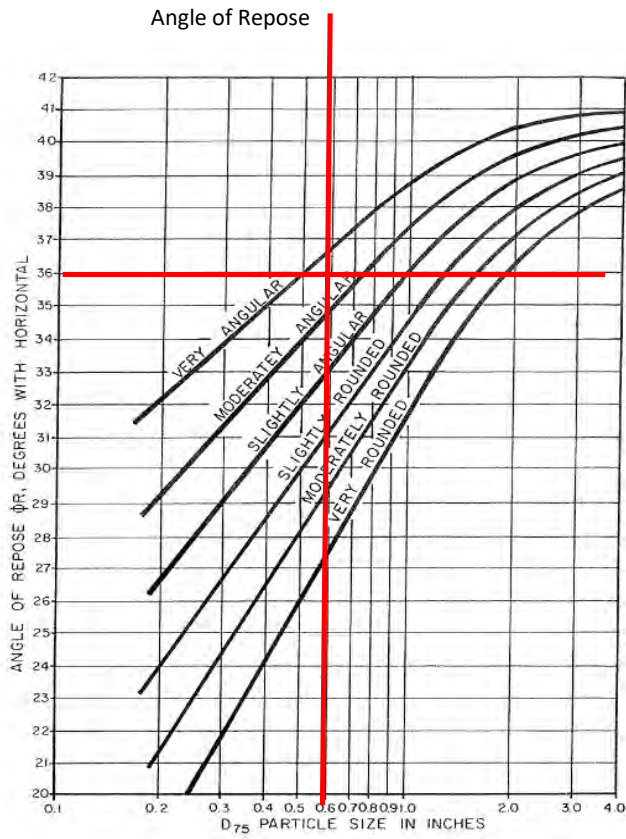
Flow Velocity

3.81

feet/second

Since the computed flow velocity is less than the maximum allowable velocity, erosion is not expected to occur.

Allowable Tractive Stress (τ_{ls})



Moderately Angular
 D_{75} 0.75 inches
 From Chart (ϕ_R) 36 Degrees

Solving for Allowable Tractive Stress

$$0.4 \left[\frac{Z^2 - \cot^2 \phi_R}{1 + Z^2} \right]^{\frac{1}{2}} D_{75}$$

0.280 lbs/ft²

Allowable Tractive Stress, from calculation above 0.280 lb/ft²

Calculated Tractive Stress, τ 0.081 lb/ft²

Since the allowable tractive stress is more than the calculated tractive stress, the channel is not erosive.

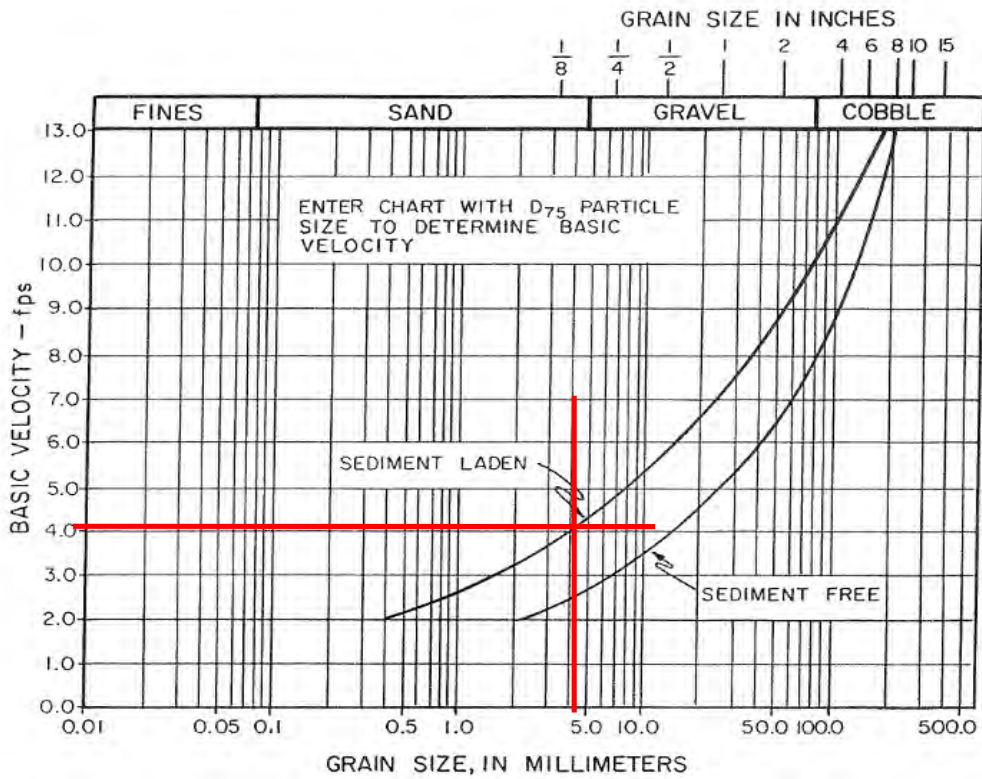
**Lateral Migration Setback Allowance for Riverine Floodplains
Level 2 Analysis**

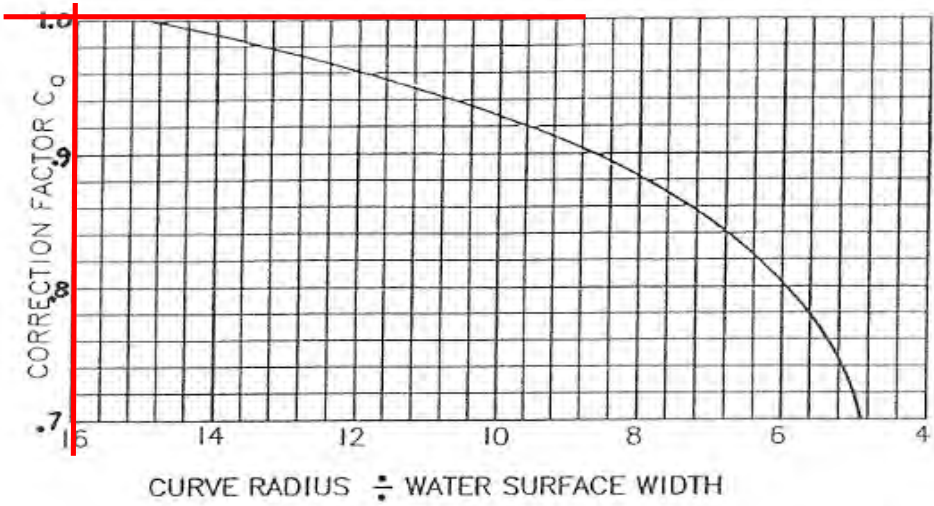
Cross Section 1422 - General Information

Bottom Width (b)	25 feet		
Side Slope (ft)	23 Horizontal	4.7 Vertical	
Channel Slope (S_e)	0.004 feet/foot		
Radius of Curvature (r)	0 feet		
Water Surface Width	45.11 feet		
Average Manning's n	0.042		
Flow Depth (Y)	4.05 feet		
Flow Velocity (V)	4.37 feet/second		
D_{75}	4.4 mm	0.17 inches	0.014 feet
D_{65}	3.7 mm	0.15 inches	0.012 feet
D_{50}	0.9 mm	0.04 inches	0.003 feet

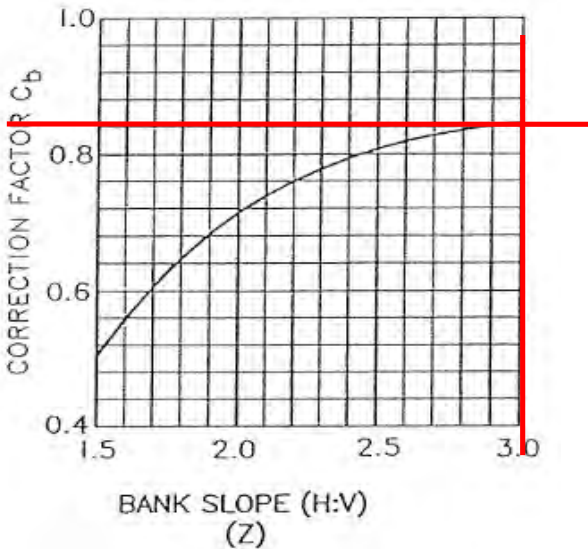
**Allowable Velocity Approach
(Assuming Sediment Laden Flow)**

Base Allowable Velocity for Earth Channels V_b 4.2 feet/sec





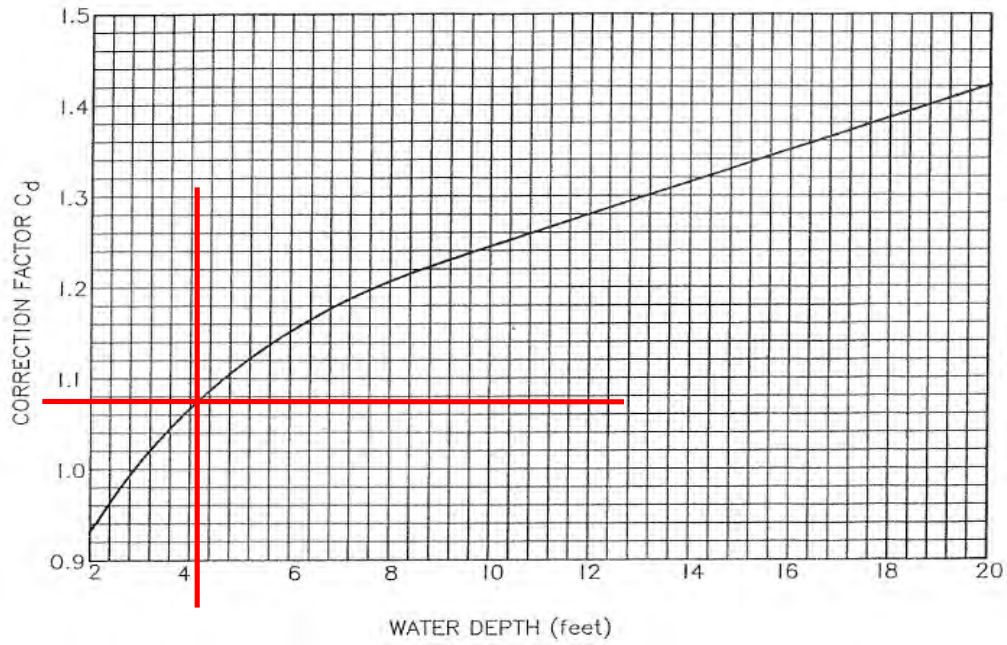
Curve Radius / Water Surface Width 0.0



Horizontal/Vertical (Z) 4.89

Correction Factor C_d For Depth of Flow

1.08



Flow Depth (Y)

4.05 feet

Maximum Allowable Velocity

3.81

feet/second

$$V_a = V_b \times C_a \times C_b \times C_d$$

Comparison of Flow Velocity of the Channel to the Maximum Allowable Velocity

Maximum Allowable Velocity

3.81

feet/second

Flow Velocity

4.37

feet/second

Since the computed flow velocity exceeds the maximum allowable velocity, erosion may be expected to occur

**Tractive Stress Analysis
(Assuming Sediment Laden Flow)**

D_{75} 4.4 mm conversion 0.17 inches

Since D_{75} is less or equal to 0.25 inches, case 2 of reference tractive stress method is used.

Assuming a water temperature of 60°F

Kinematic Velocity (v) 0.0000121 ft² / sec
 Density (ρ) 1.94 slugs/ft³
 Gravity 32.17 ft/sec²

Finding Values Needed for Graphs

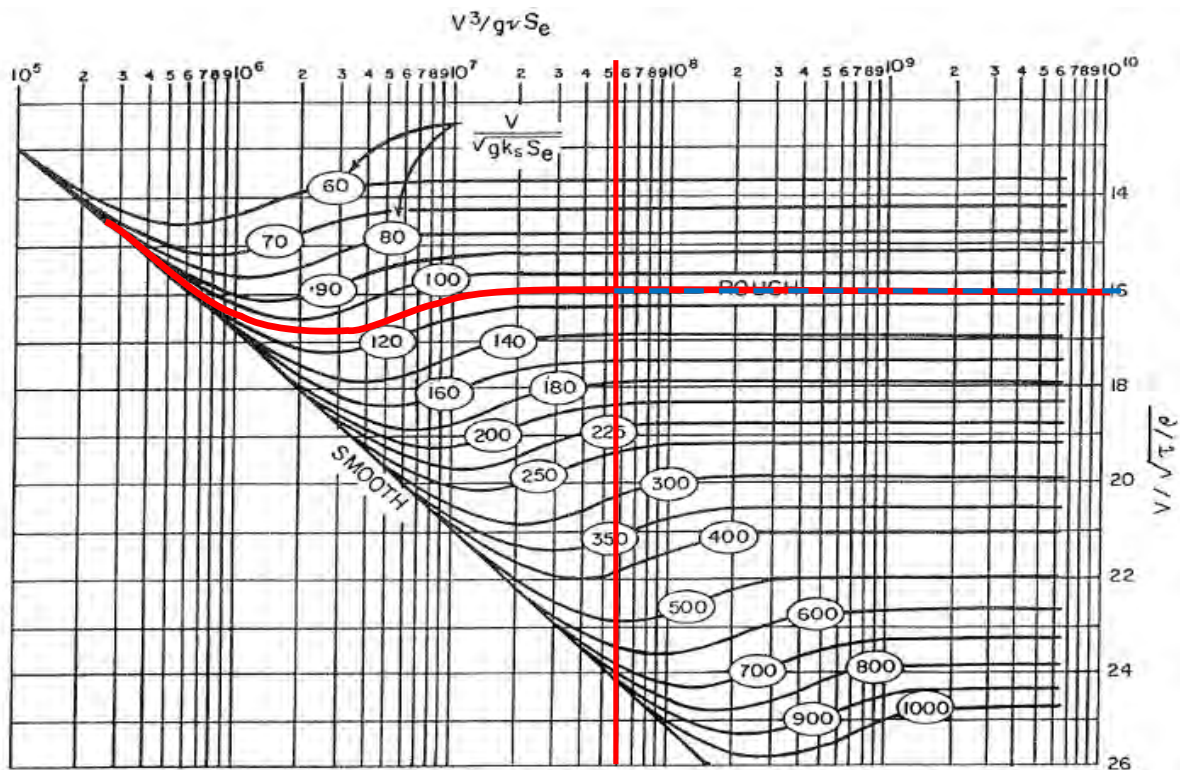
$$V^3 / (g v S_e)$$

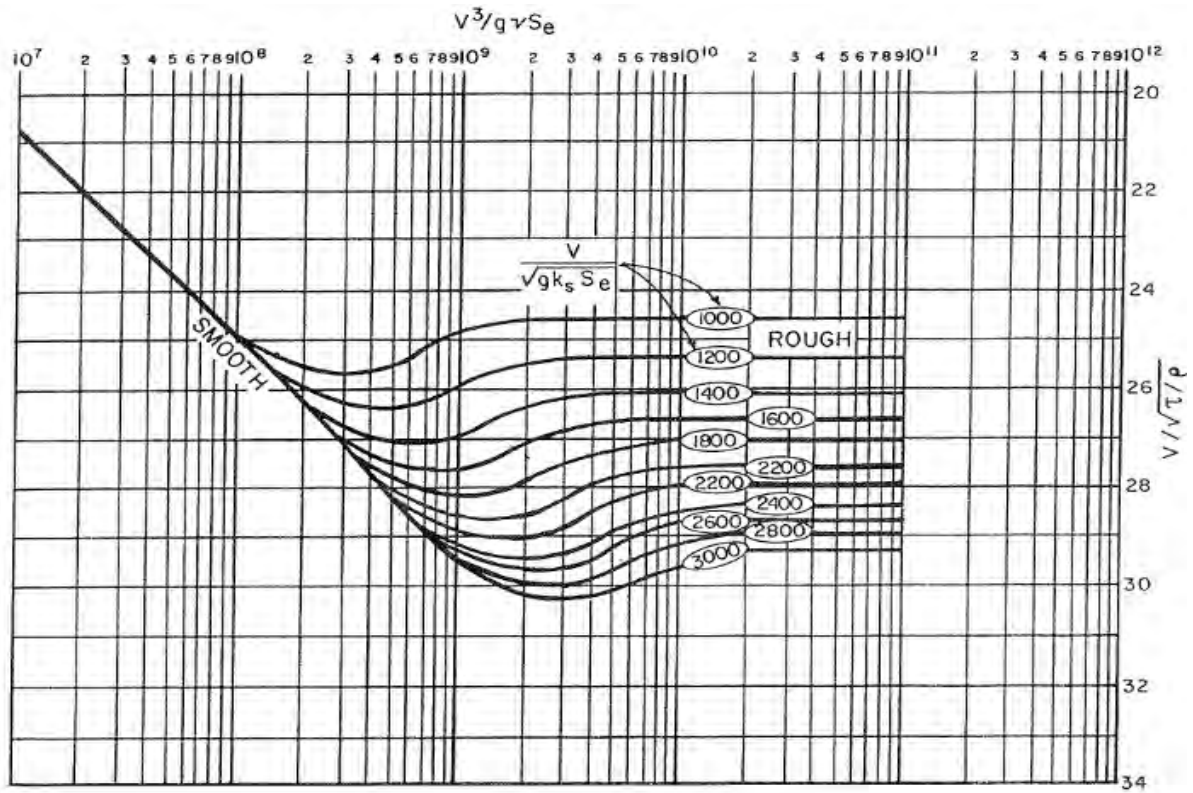
Value 1 5.36E+07

$$V / [(g D_{65} S_e)^{0.5}]$$

Value 2 110.6

Graphic Solution of Reference Tractive Stress



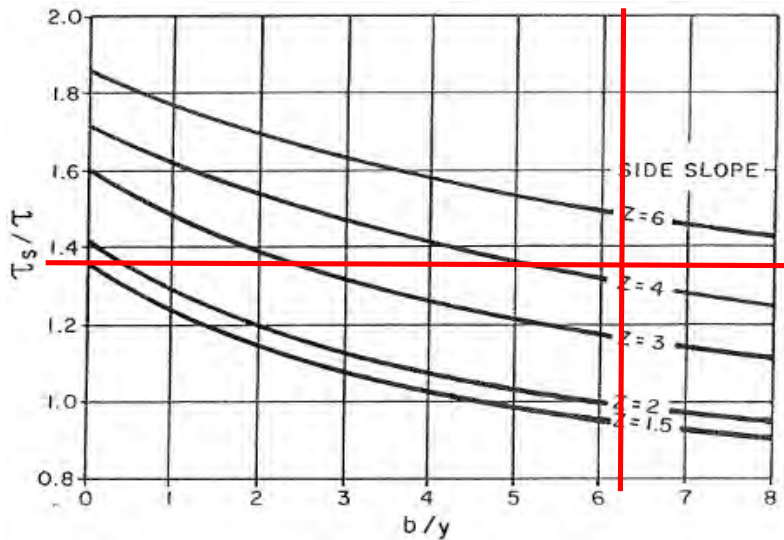


$$V/\sqrt{\tau/\rho}$$

From Graph Above 16

Solving the above equation for τ 0.14 lb/ft²

Applied Maximum Tractive Stress, τ_s , on sides of straight trapezoidal channels

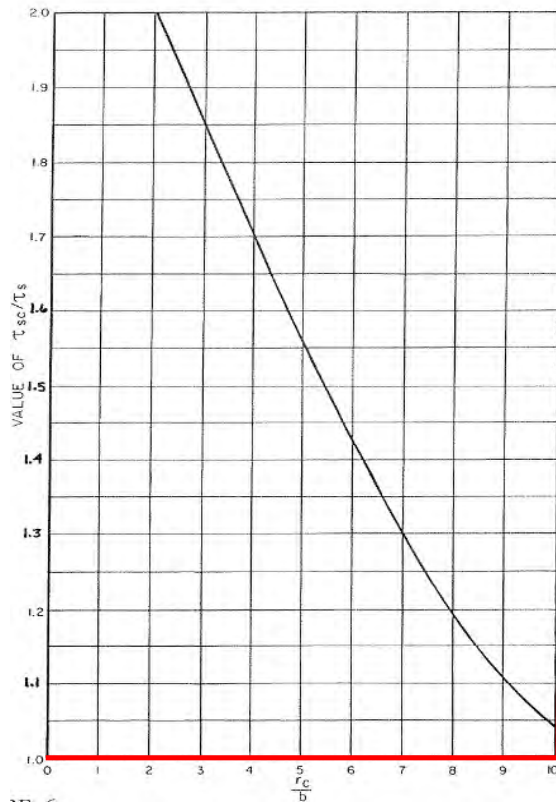


Bottom Width/Flow depth Horizontal/Vertical (Z) 6.17 4.89

From Graph 1.38

Solving for τ_s 0.20 lb/ft²

Actual Maximum Tractive Stress, τ_s on sides of trapezoidal channels within a curved reach



Radius of Curvature/Bottom Width

N/A

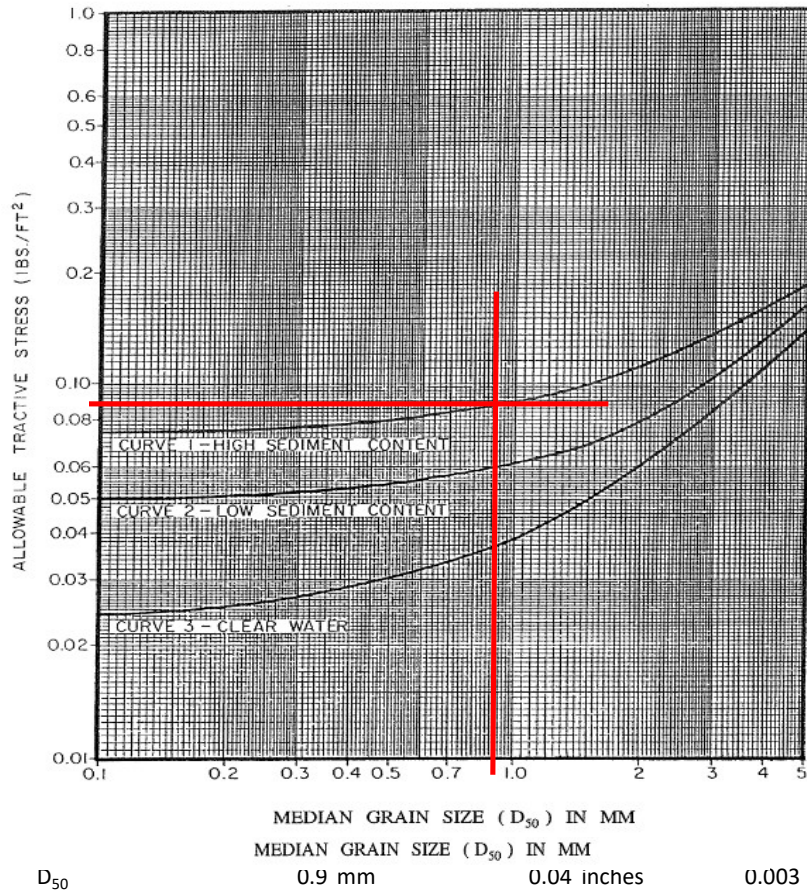
From Graph Above

1.00

Solving for τ_s

0.20 lb/ft²

Maximum Allowable Tractive Stress For Non-Cohesive Soils, $D_{75} < 0.25''$



Allowable Tractive Stress, from graph above 0.092 lb/ft²

Calculated Tractive Stress, τ 0.14 lb/ft²

Since the allowable tractive stress is less than the calculated tractive stress, the channel is erosive.

**Lateral Migration Setback Allowance for Riverine Floodplains
Level 2 Analysis**

Cross Section 1422 - General Information

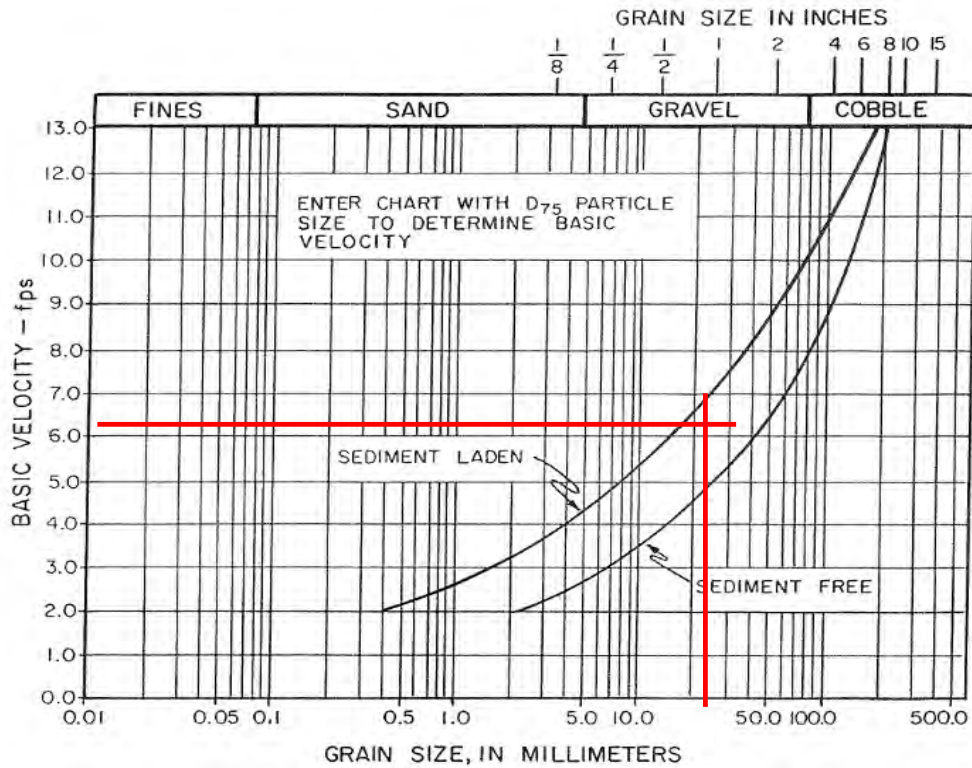
Bottom Width (b)	25 feet	
Side Slope (ft)	23 Horizontal	4.7 Vertical
Channel Slope (S_c)	0.004 feet/foot	
Radius of Curvature (r)	0 feet	
Water Surface Width	45.11 feet	
Average Manning's n	0.042	

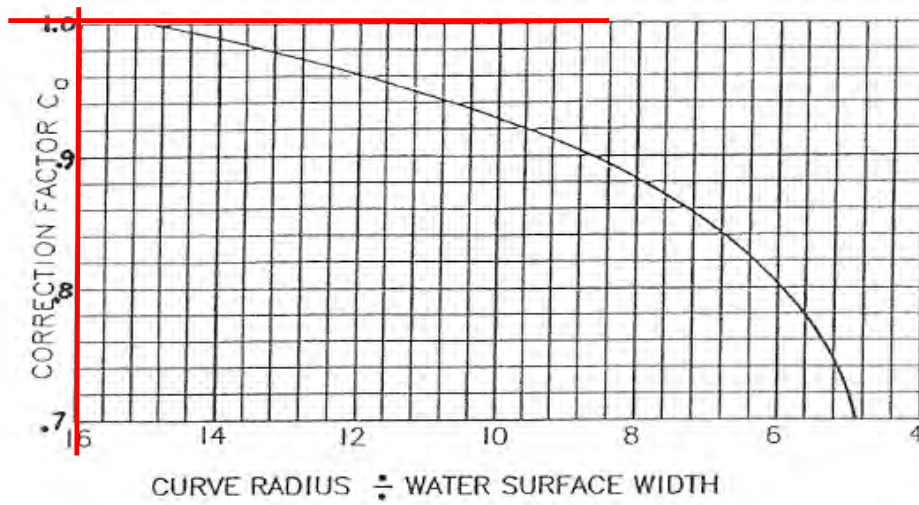
Flow Depth (Y)	4.05 feet
Flow Velocity (V)	4.37 feet/second

D_{75}	19 mm	0.75 inches	0.062 feet
D_{65}	9.1 mm	0.36 inches	0.030 feet
D_{50}	5.2 mm	0.20 inches	0.017 feet

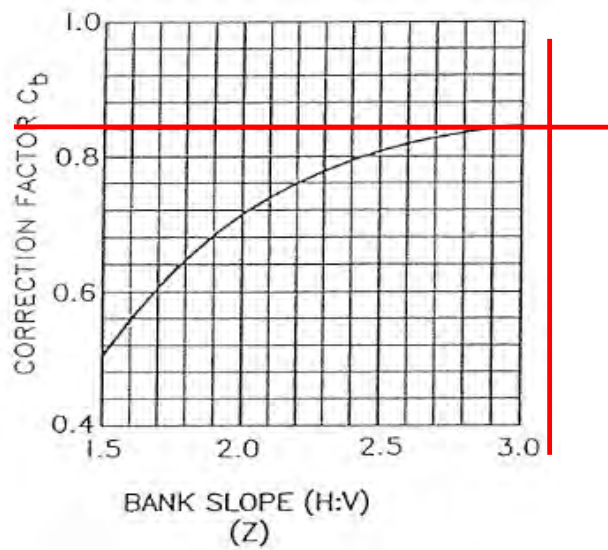
**Allowable Velocity Approach
(Assuming Sediment Laden Flow)**

Base Allowable Velocity for Earth Channels V_b 6.3 feet/sec





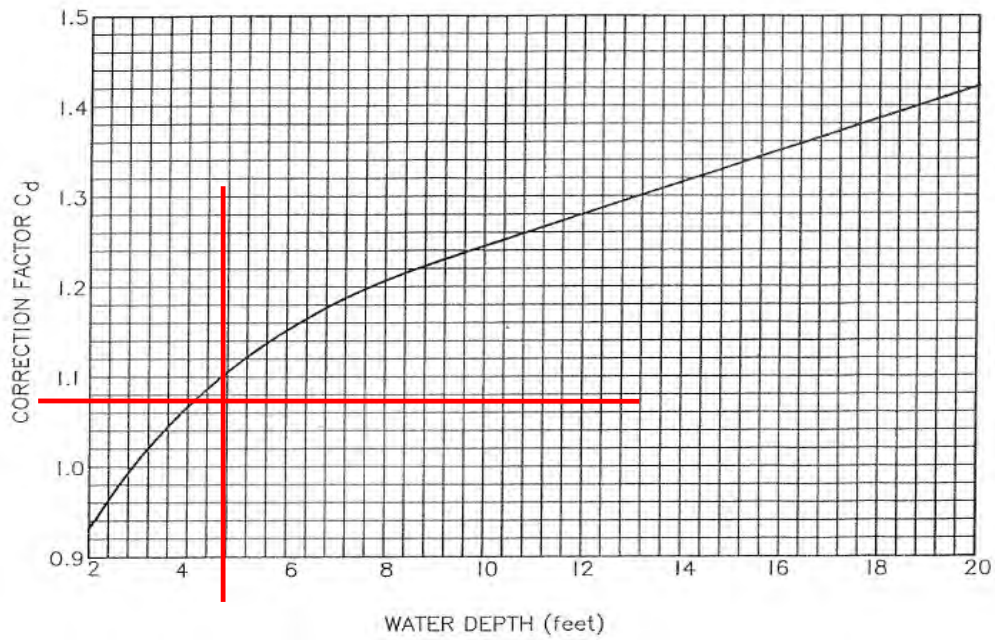
Curve Radius / Water Surface Width 0.0



Horizontal/Vertical (Z) 4.89

Correction Factor C_d For Depth of Flow

1.08



Flow Depth (Y)

4.05 feet

Maximum Allowable Velocity

5.72

feet/second

$$V_a = V_b \times C_a \times C_b \times C_d$$

Comparison of Flow Velocity of the Channel to the Maximum Allowable Velocity

Maximum Allowable Velocity

5.72

feet/second

Flow Velocity

4.37

feet/second

Since the computed flow velocity is less than the maximum allowable velocity, erosion is not expected to occur.

**Tractive Stress Analysis
(Assuming Sediment Laden Flow)**

D₇₅ 19 mm conversion 0.75 inches

Since the D₇₅ is more than to 0.25 inches and less than 5.0 inches, case 1 of the reference tractive method is used.

Assuming a water temperature of 60°F

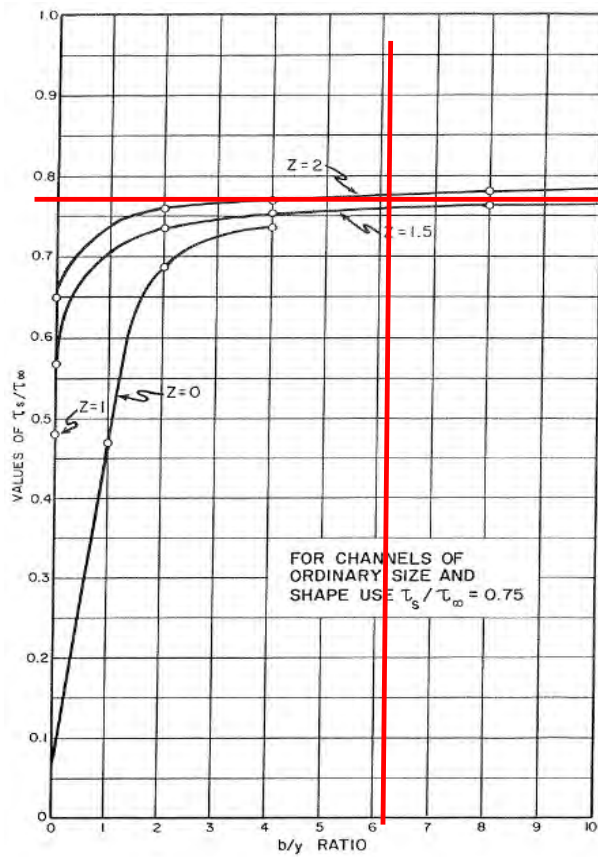
Kinematic Velocity (v) 0.0000121 ft² / sec
 Density (ρ) 1.94 slugs/ft³
 Gravity 32.17 ft/sec²
 Unit Weight of Water (γ) 62.4 lbs/ft³

Tractive Stress for Soils in an infinitely Wide Channel (τ_∞)

$$\gamma_w Y \left[\frac{D_{75}^{\frac{1}{6}}}{39n} \right]^2 S_e$$

0.149 lbs/ft²

Actual Maximum Tractive Stress, τ_s on Sides of Straight Trapezoial Channels

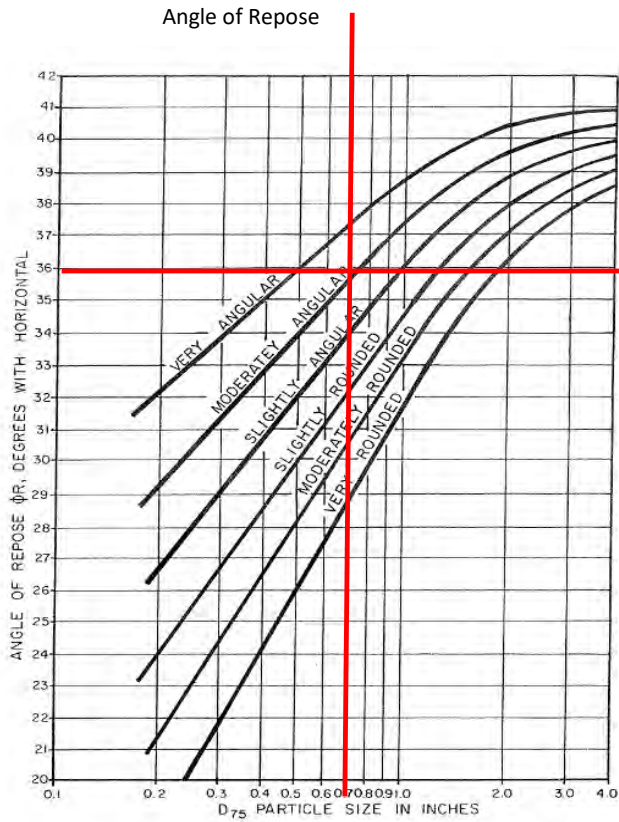


b/y Ratio 6.17 ft/ft
 Z (H/V) 4.89 ft/ft

 τ_s/τ_∞ 0.77

 τ_s 0.115 lbs/ft²

Allowable Tractive Stress (τ_s)



Moderately Angular
 D_{75} 0.75 inches
 From Chart (ϕR) 36 Degrees

Solving for Allowable Tractive Stress

$$0.4 \left[\frac{Z^2 - \cot^2 \phi R}{1 + Z^2} \right]^{\frac{1}{2}} D_{75}$$

0.275 lbs/ft²

Allowable Tractive Stress, from calculation above 0.275 lb/ft²

Calculated Tractive Stress, τ 0.12 lb/ft²

Since the allowable tractive stress is more than the calculated tractive stress, the channel is not erosive.

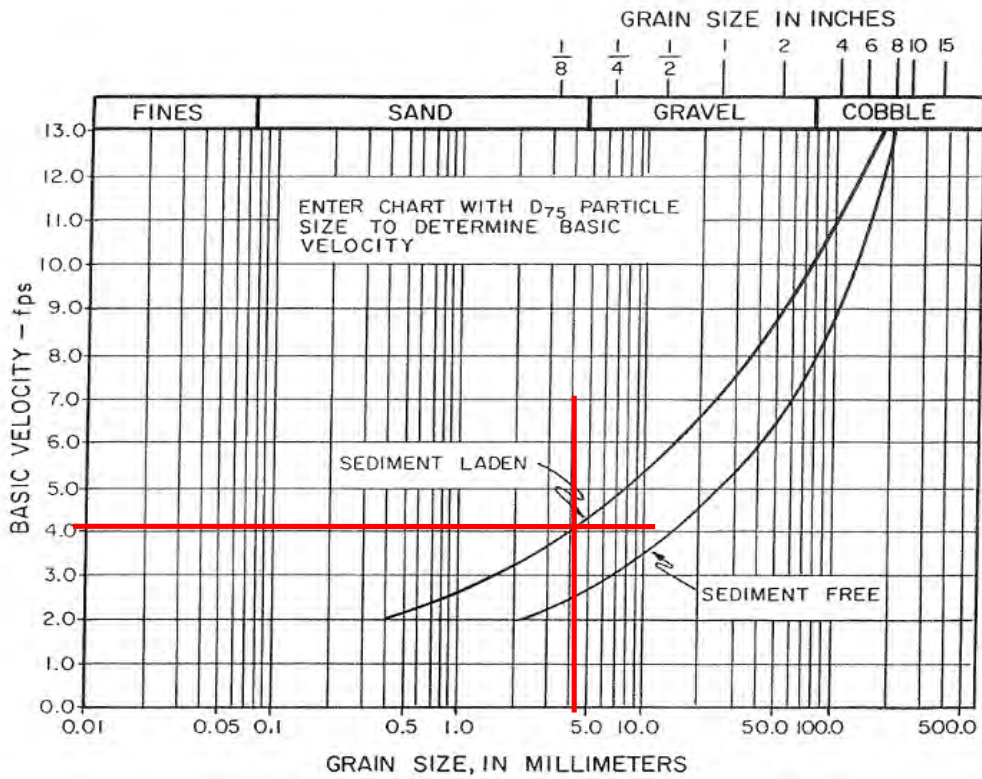
**Lateral Migration Setback Allowance for Riverine Floodplains
Level 2 Analysis**

Cross Section 1496 - General Information

Bottom Width (b)	24.9 feet		
Side Slope (ft)	15.5 Horizontal	2.5 Vertical	
Channel Slope (S_e)	0.004 feet/foot		
Radius of Curvature (r)	0 feet		
Water Surface Width	42.38 feet		
Average Manning's n	0.034		
Flow Depth (Y)	4.29 feet		
Flow Velocity (V)	5.01 feet/second		
D_{75}	4.4 mm	0.17 inches	0.014 feet
D_{65}	3.7 mm	0.15 inches	0.012 feet
D_{50}	0.9 mm	0.04 inches	0.003 feet

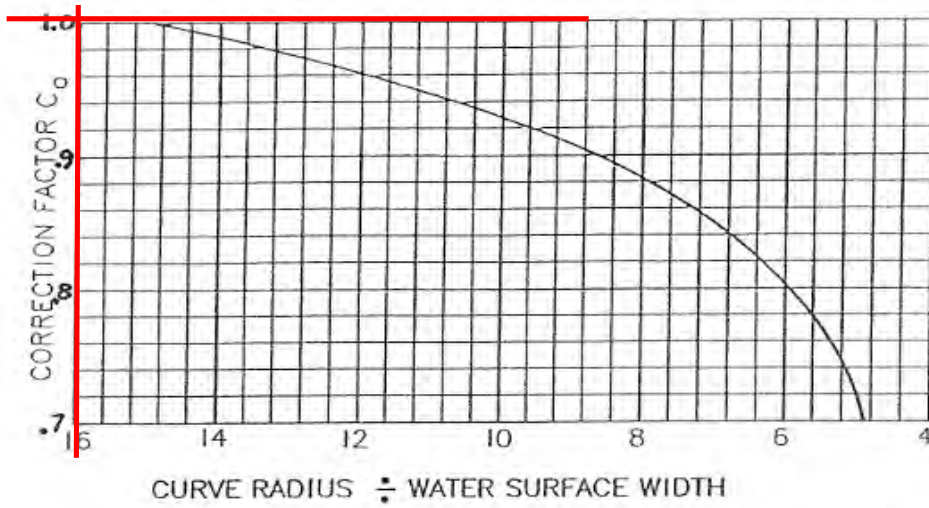
**Allowable Velocity Approach
(Assuming Sediment Laden Flow)**

Base Allowable Velocity for Earth Channels V_b 4.2 feet/sec



Correction Factor C_a For Channel Alignment

1

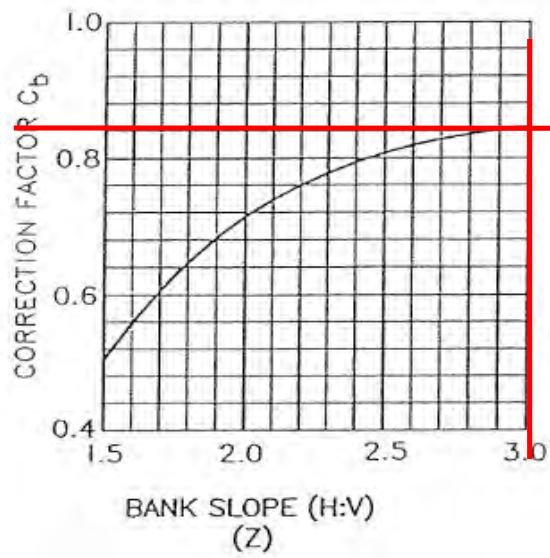


Curve Radius / Water Surface Width

0.0

Correction Factor C_b For Bank Slope

0.84

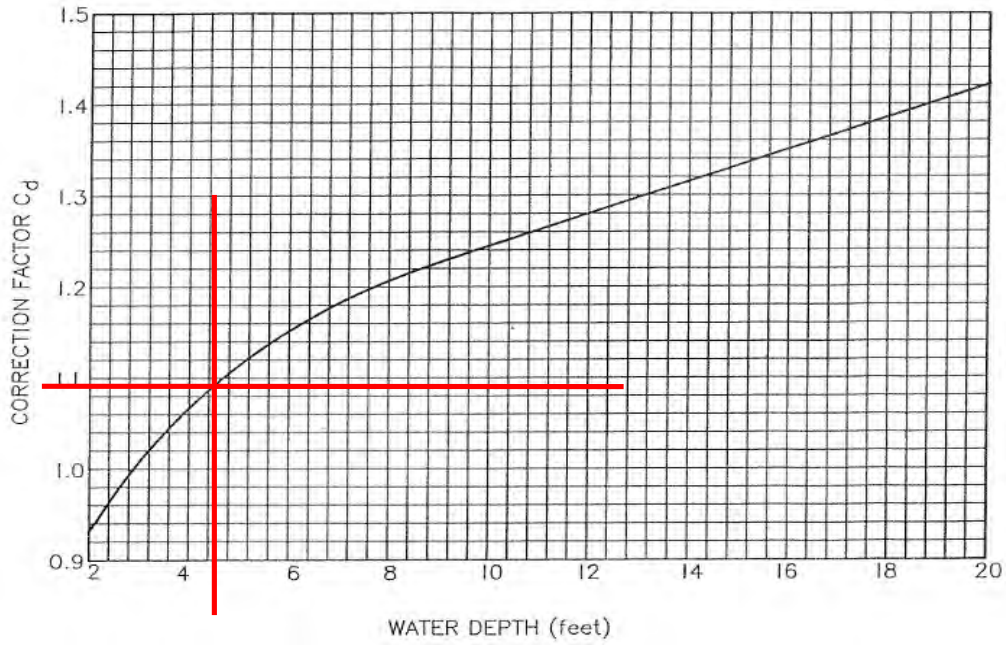


Horizontal/Vertical (Z)

6.20

Correction Factor C_d For Depth of Flow

1.09



Flow Depth (Y) 4.29 feet

Maximum Allowable Velocity 3.85 feet/second

$$V_a = V_b \times C_a \times C_b \times C_d$$

Comparison of Flow Velocity of the Channel to the Maximum Allowable Velocity

Maximum Allowable Velocity 3.85 feet/second

Flow Velocity 5.01 feet/second

Since the computed flow velocity exceeds the maximum allowable velocity, erosion may be expected to occur

**Tractive Stress Analysis
(Assuming Sediment Laden Flow)**

D_{75} 4.4 mm conversion 0.17 inches

Since D_{75} is less or equal to 0.25 inches, case 2 of reference tractive stress method is used.

Assuming a water temperature of 60°F

Kinematic Velocity (v) 0.0000121 ft² / sec
 Density (ρ) 1.94 slugs/ft³
 Gravity 32.17 ft/sec²

Finding Values Needed for Graphs

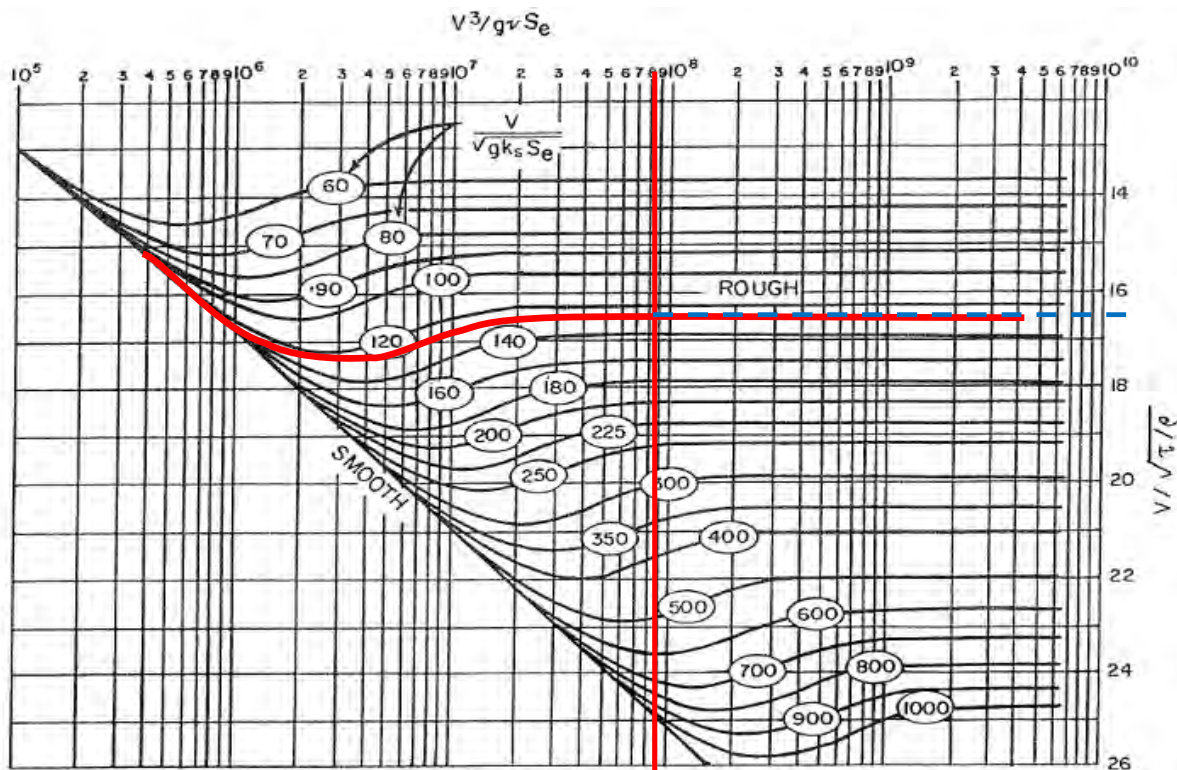
$$V^3 / (g v S_e)$$

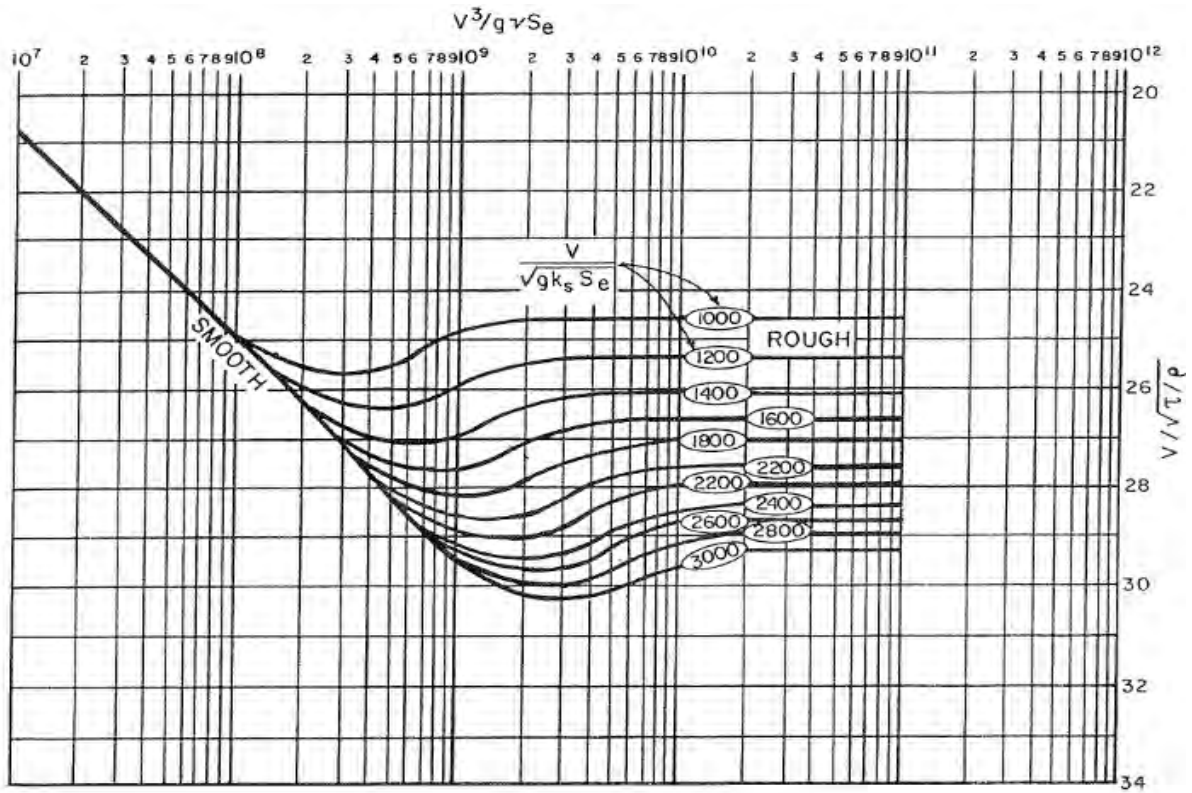
Value 1 8.08E+07

$$V / [(g D_{65} S_e)^{0.5}]$$

Value 2 126.8

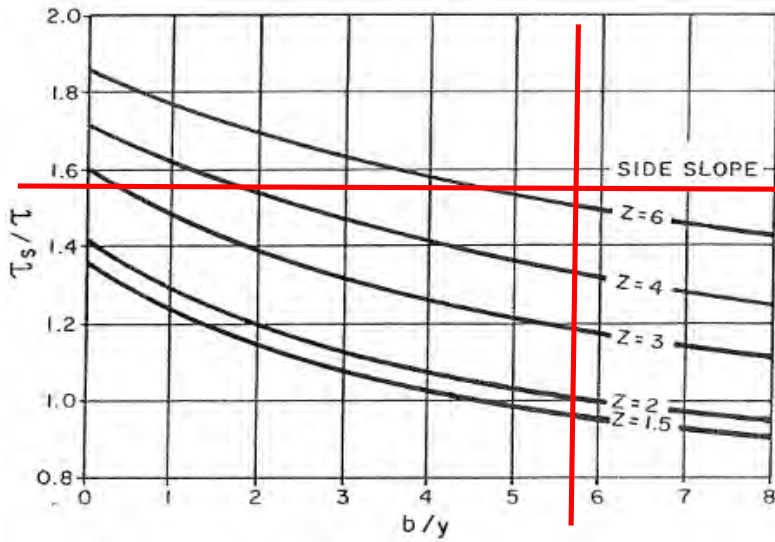
Graphic Solution of Reference Tractive Stress





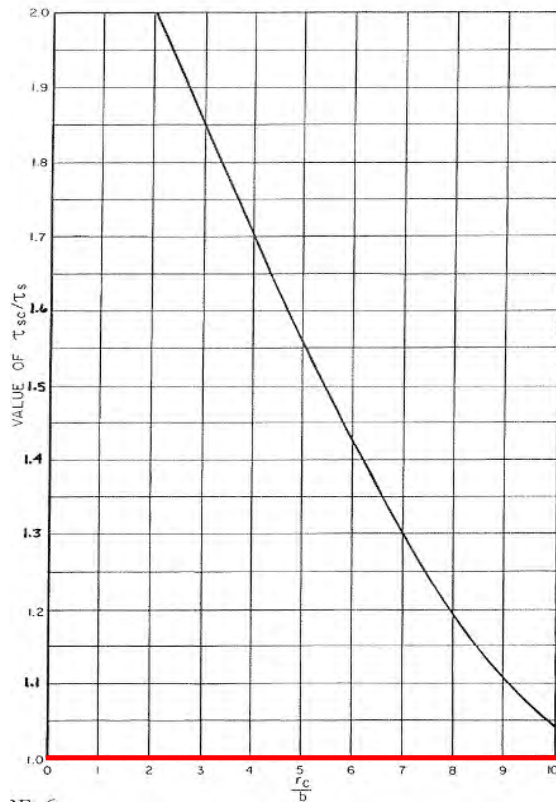
$V/\sqrt{\tau/\rho}$ From Graph Above 16.6
 Solving the above equation for τ 0.18 lb/ft²

Applied Maximum Tractive Stress, τ_s , on sides of straight trapezoidal channels



Bottom Width/Flow depth 5.80
 Horizontal/Vertical (Z) 6.20
 From Graph 1.57
 Solving for τ_s 0.28 lb/ft²

Actual Maximum Tractive Stress, τ_s on sides of trapezoidal channels within a curved reach

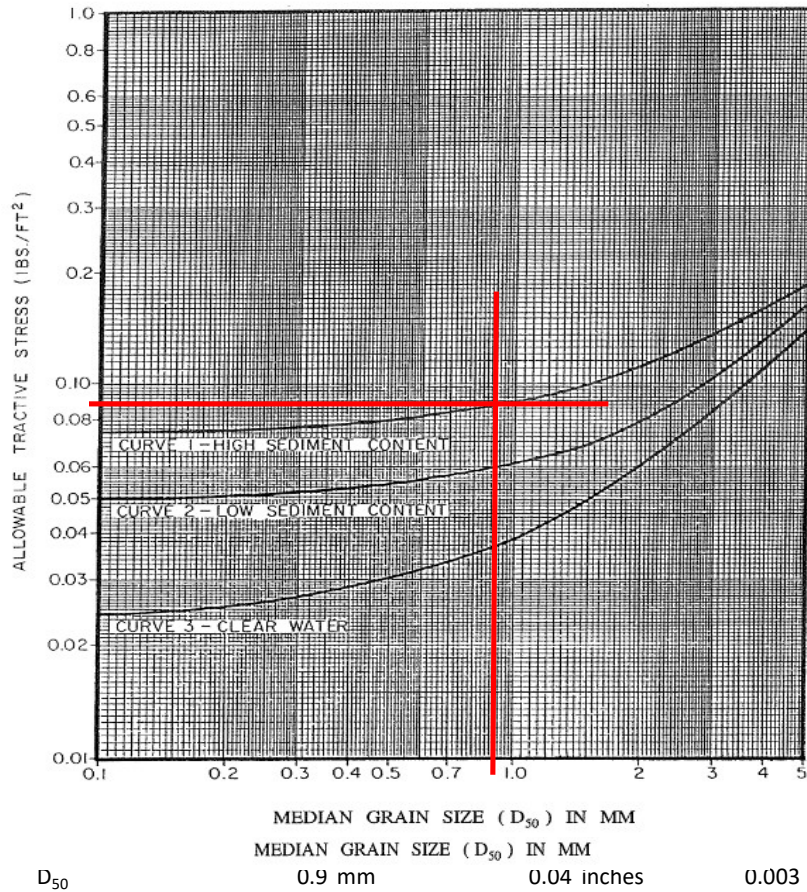


Radius of Curvature/Bottom Width N/A

From Graph Above 1.00

Solving for τ_s 0.28 lb/ft²

Maximum Allowable Tractive Stress For Non-Cohesive Soils, $D_{75} < 0.25''$



Allowable Tractive Stress, from graph above 0.092 lb/ft²

Calculated Tractive Stress, τ 0.18 lb/ft²

Since the allowable tractive stress is less than the calculated tractive stress, the channel is erosive.

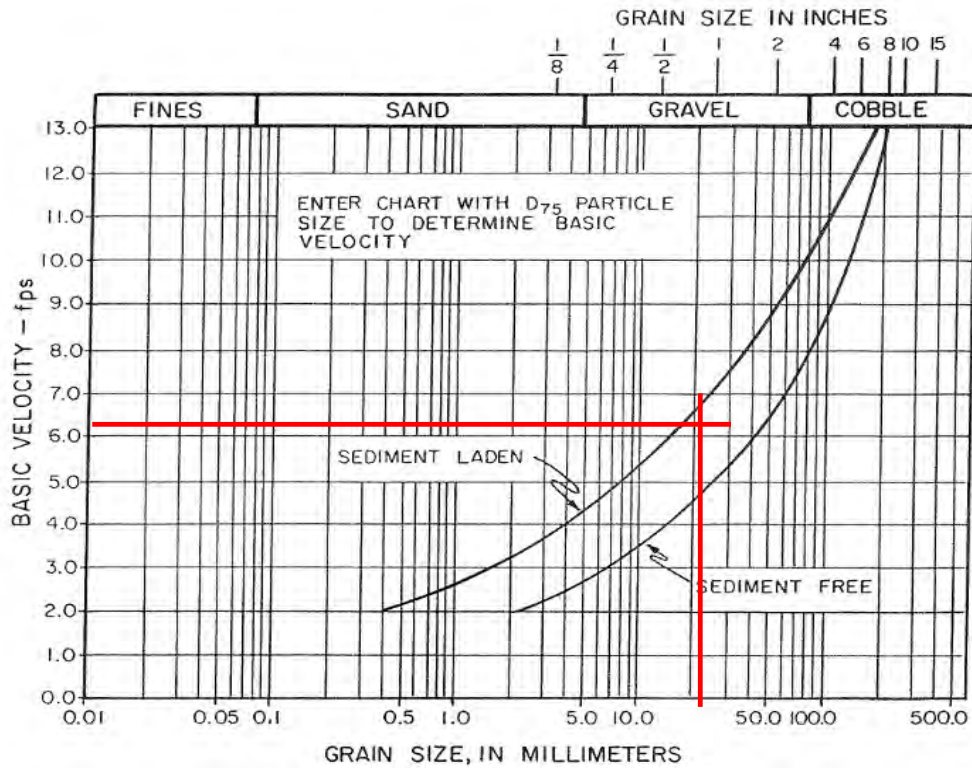
**Lateral Migration Setback Allowance for Riverine Floodplains
Level 2 Analysis**

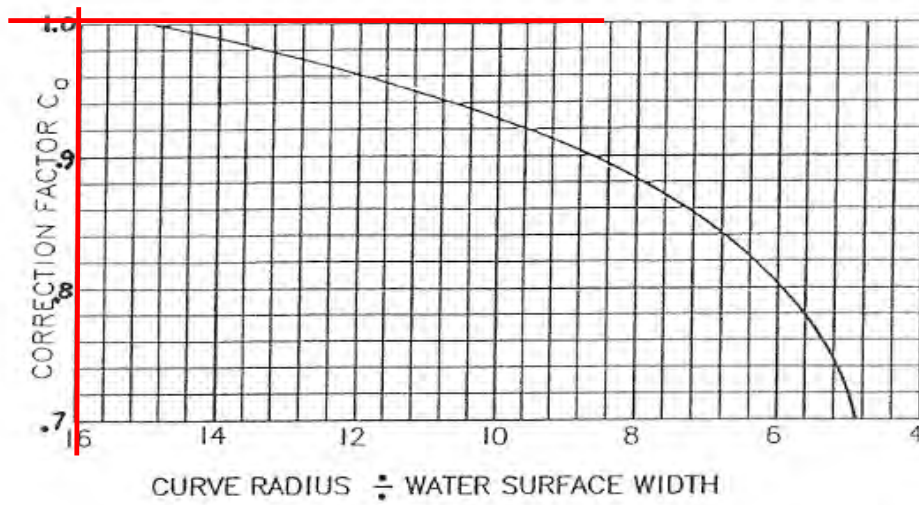
Cross Section 1496 - General Information

Bottom Width (b)	24.9 feet		
Side Slope (ft)	15.5 Horizontal	2.5 Vertical	
Channel Slope (S_c)	0.004 feet/foot		
Radius of Curvature (r)	0 feet		
Water Surface Width	42.38 feet		
Average Manning's n	0.034		
Flow Depth (Y)	4.29 feet		
Flow Velocity (V)	5.01 feet/second		
D_{75}	19 mm	0.75 inches	0.062 feet
D_{65}	9.1 mm	0.36 inches	0.030 feet
D_{50}	5.2 mm	0.20 inches	0.017 feet

**Allowable Velocity Approach
(Assuming Sediment Laden Flow)**

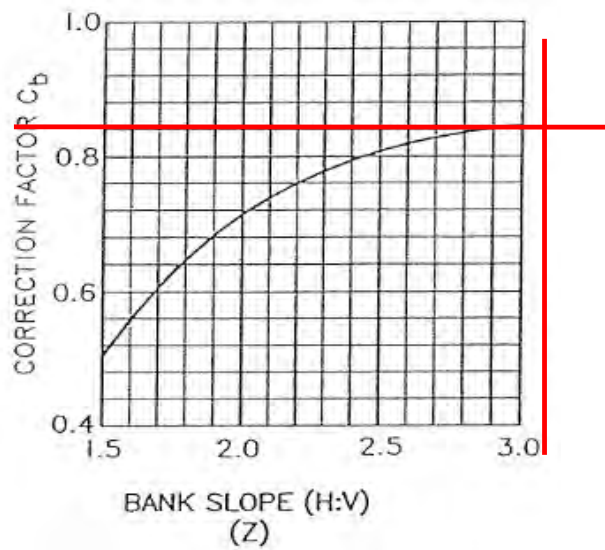
Base Allowable Velocity for Earth Channels V_b 6.3 feet/sec





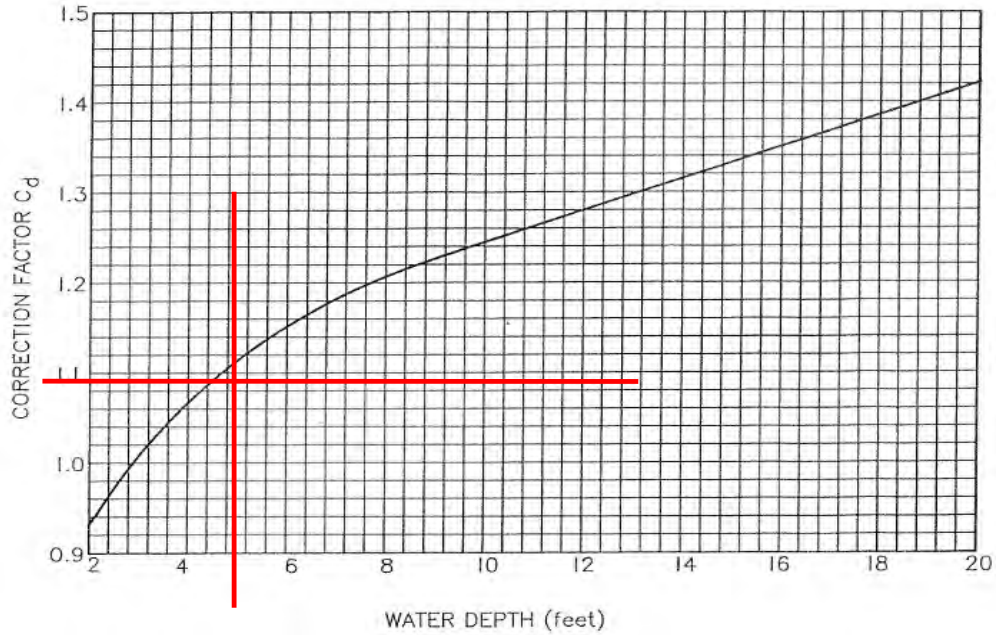
Curve Radius / Water Surface Width

0.0



Horizontal/Vertical (Z)

6.20



Flow Depth (Y)

4.29 feet

Maximum Allowable Velocity

5.77

feet/second

$$V_a = V_b \times C_a \times C_b \times C_d$$

Comparison of Flow Velocity of the Channel to the Maximum Allowable Velocity

Maximum Allowable Velocity

5.77

feet/second

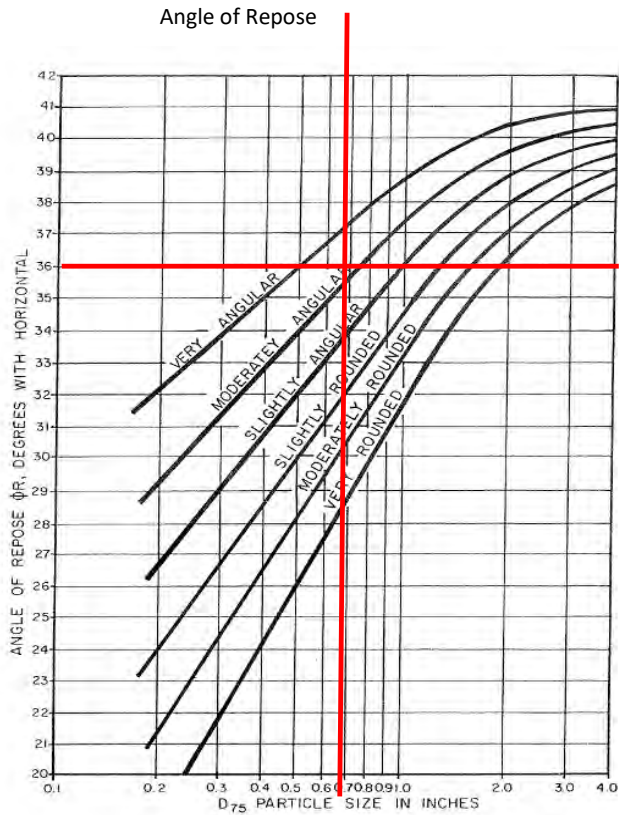
Flow Velocity

5.01

feet/second

Since the computed flow velocity is less than the maximum allowable velocity, erosion is not expected to occur.

Allowable Tractive Stress (τ_s)



Moderately Angular
 D_{75} 0.75 inches
 From Chart (ϕ_R) 36 Degrees

Solving for Allowable Tractive Stress

$$0.4 \left[\frac{Z^2 - \cot^2 \phi_R}{1 + Z^2} \right]^{\frac{1}{2}} D_{75}$$

0.284 lbs/ft²

Allowable Tractive Stress, from calculation above 0.284 lb/ft²

Calculated Tractive Stress, τ 0.19 lb/ft²

Since the allowable tractive stress is more than the calculated tractive stress, the channel is not erosive.

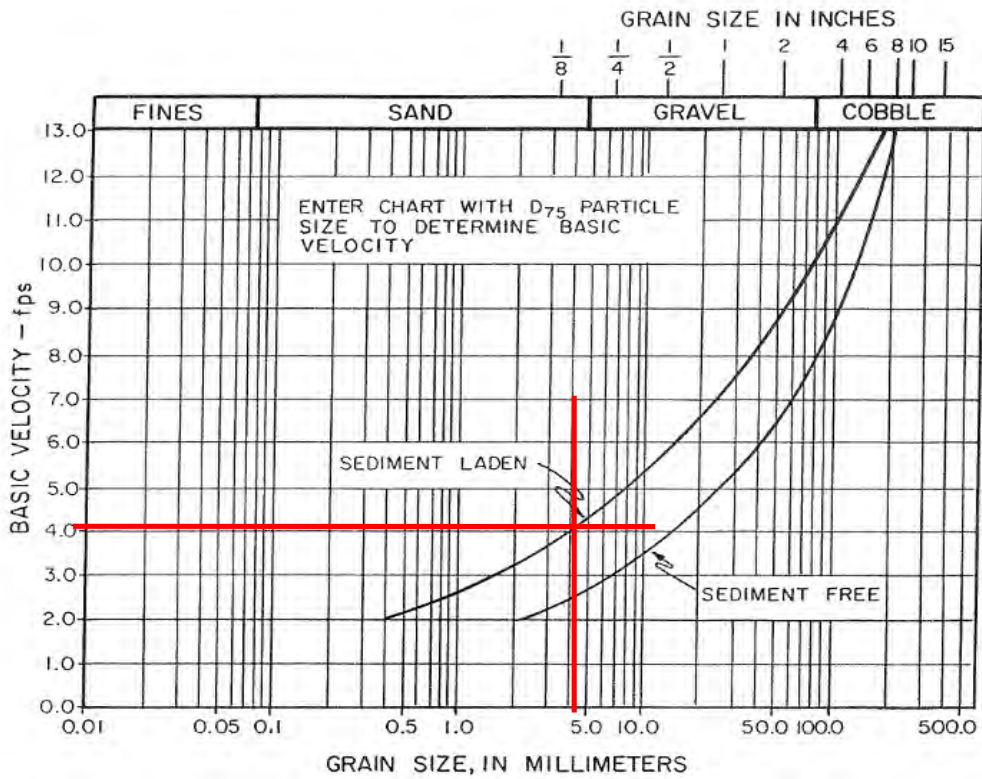
**Lateral Migration Setback Allowance for Riverine Floodplains
Level 2 Analysis**

Cross Section 1572 - General Information

Bottom Width (b)	25.47 feet		
Side Slope (ft)	9.7 Horizontal	5.3 Vertical	
Channel Slope (S_e)	0.0012 feet/foot		
Radius of Curvature (r)	0 feet		
Water Surface Width	39.98 feet		
Average Manning's n	0.026		
Flow Depth (Y)	4.19 feet		
Flow Velocity (V)	3.48 feet/second		
D_{75}	4.4 mm	0.17 inches	0.014 feet
D_{65}	3.7 mm	0.15 inches	0.012 feet
D_{50}	0.9 mm	0.04 inches	0.003 feet

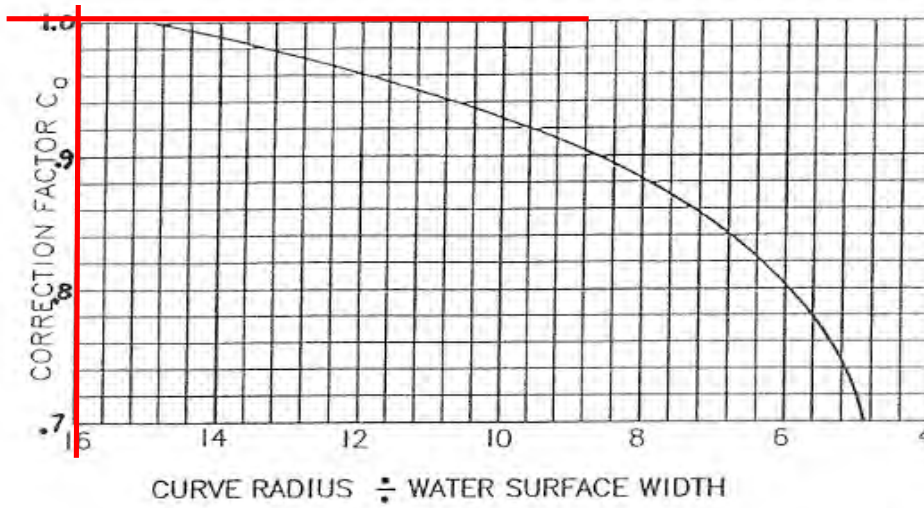
**Allowable Velocity Approach
(Assuming Sediment Laden Flow)**

Base Allowable Velocity for Earth Channels V_b 4.2 feet/sec



Correction Factor C_a For Channel Alignment

1

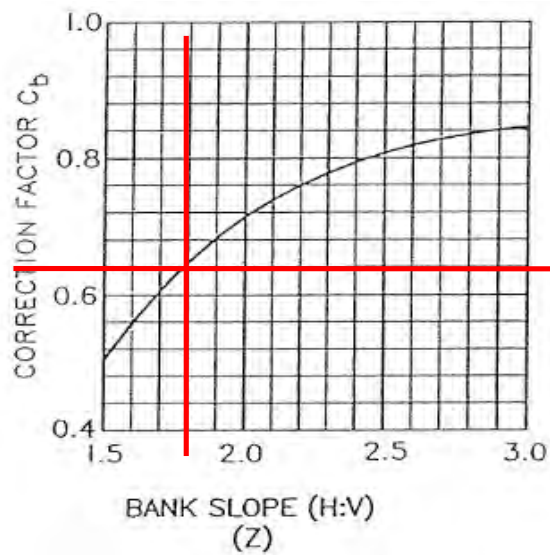


Curve Radius / Water Surface Width

0.0

Correction Factor C_b For Bank Slope

0.62

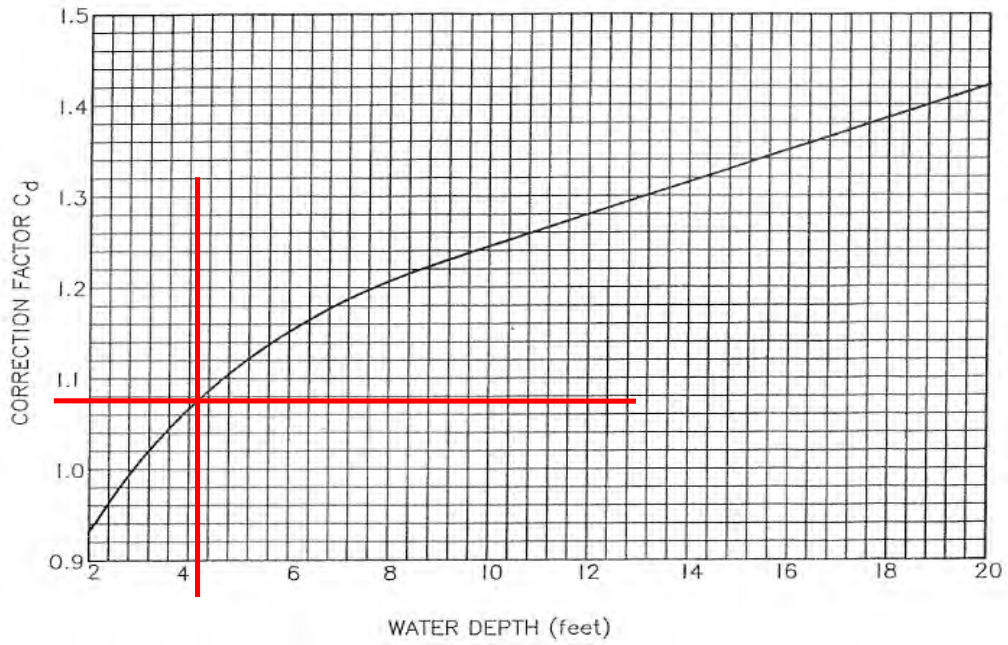


Horizontal/Vertical (Z)

1.83

Correction Factor C_d For Depth of Flow

1.08



Flow Depth (Y)

4.19 feet

Maximum Allowable Velocity

2.81

feet/second

$$V_a = V_b \times C_a \times C_b \times C_d$$

Comparison of Flow Velocity of the Channel to the Maximum Allowable Velocity

Maximum Allowable Velocity

2.81

feet/second

Flow Velocity

3.48

feet/second

Since the computed flow velocity exceeds the maximum allowable velocity, erosion may be expected to occur

**Tractive Stress Analysis
(Assuming Sediment Laden Flow)**

D_{75} 4.4 mm conversion 0.17 inches

Since D_{75} is less or equal to 0.25 inches, case 2 of reference tractive stress method is used.

Assuming a water temperature of 60°F

Kinematic Velocity (v) 0.0000121 ft² / sec
 Density (ρ) 1.94 slugs/ft³
 Gravity 32.17 ft/sec²

Finding Values Needed for Graphs

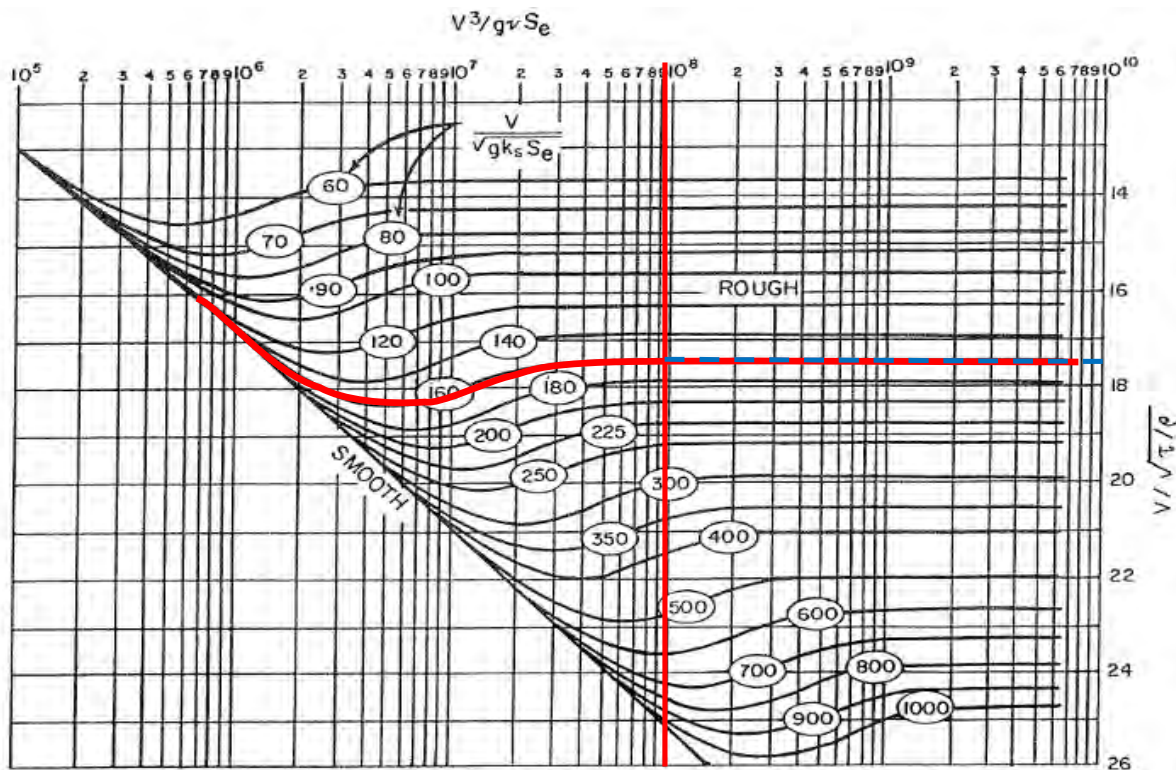
$$V^3 / (g v S_e)$$

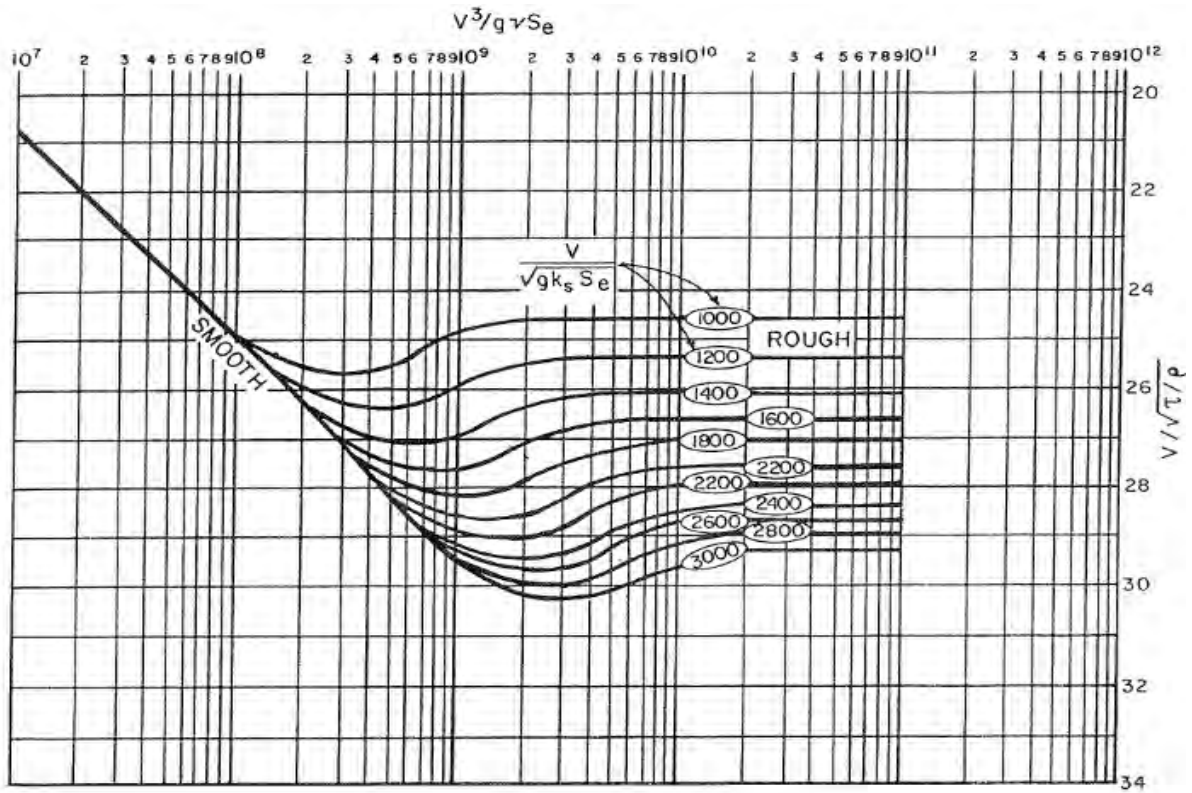
Value 1 9.02E+07

$$V / [(g D_{65} S_e)^{0.5}]$$

Value 2 160.8

Graphic Solution of Reference Tractive Stress



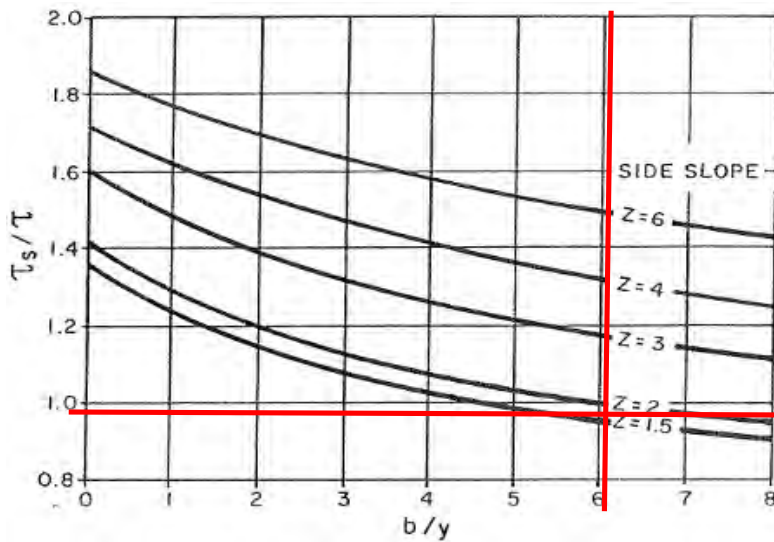


$$V/\sqrt{\tau/\rho}$$

From Graph Above 17.6

Solving the above equation for τ 0.08 lb/ft²

Applied Maximum Tractive Stress, τ_s , on sides of straight trapezoidal channels

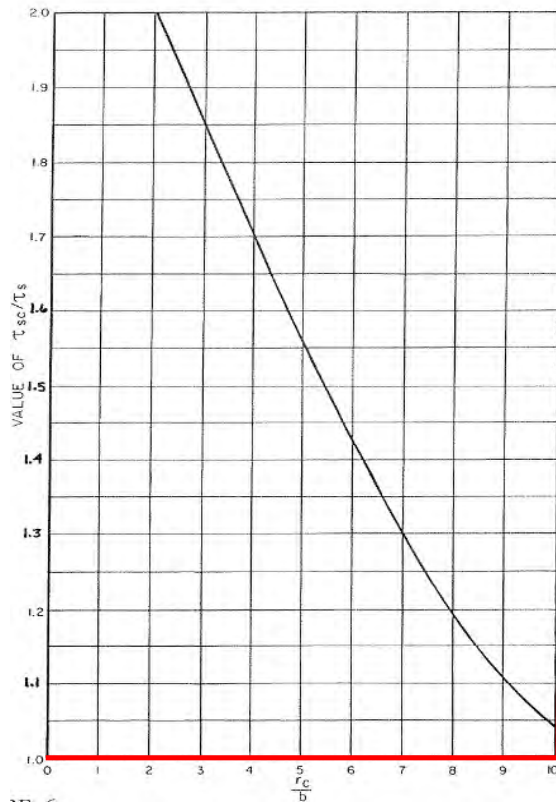


Bottom Width/Flow depth Horizontal/Vertical (Z) 6.08 1.83

From Graph 0.98

Solving for τ_s 0.07 lb/ft²

Actual Maximum Tractive Stress, τ_s on sides of trapezoidal channels within a curved reach



Radius of Curvature/Bottom Width

N/A

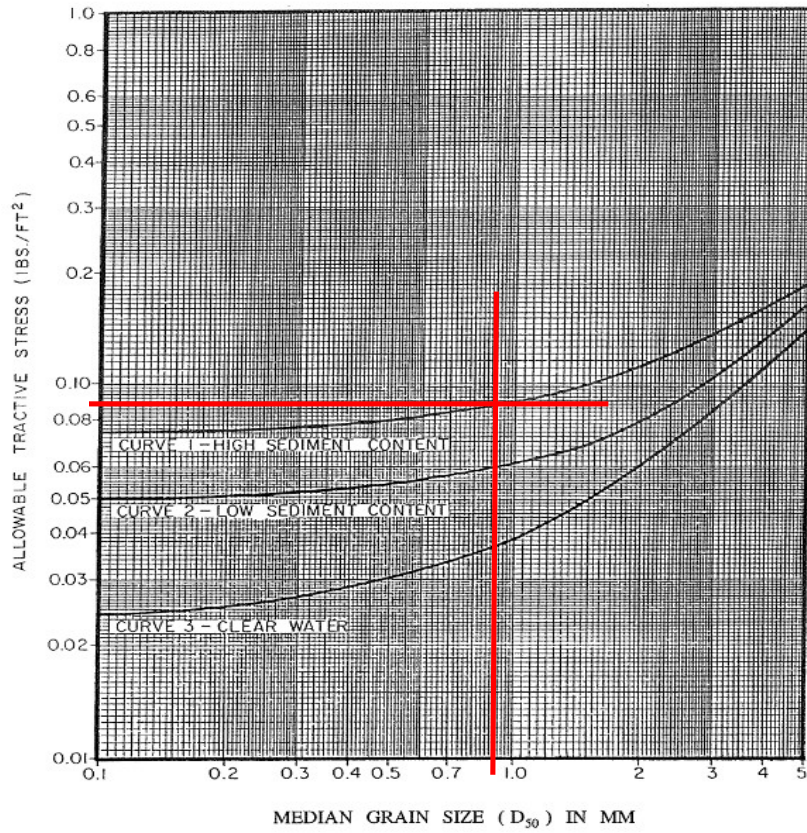
From Graph Above

1.00

Solving for τ_s

0.07 lb/ft²

Maximum Allowable Tractive Stress For Non-Cohesive Soils, $D_{75} < 0.25''$



D_{50} 0.9 mm 0.04 inches 0.003 feet

Allowable Tractive Stress, from graph above 0.092 lb/ft²

Calculated Tractive Stress, τ 0.08 lb/ft²

Since the allowable tractive stress is more than the calculated tractive stress, the channel is not erosive.

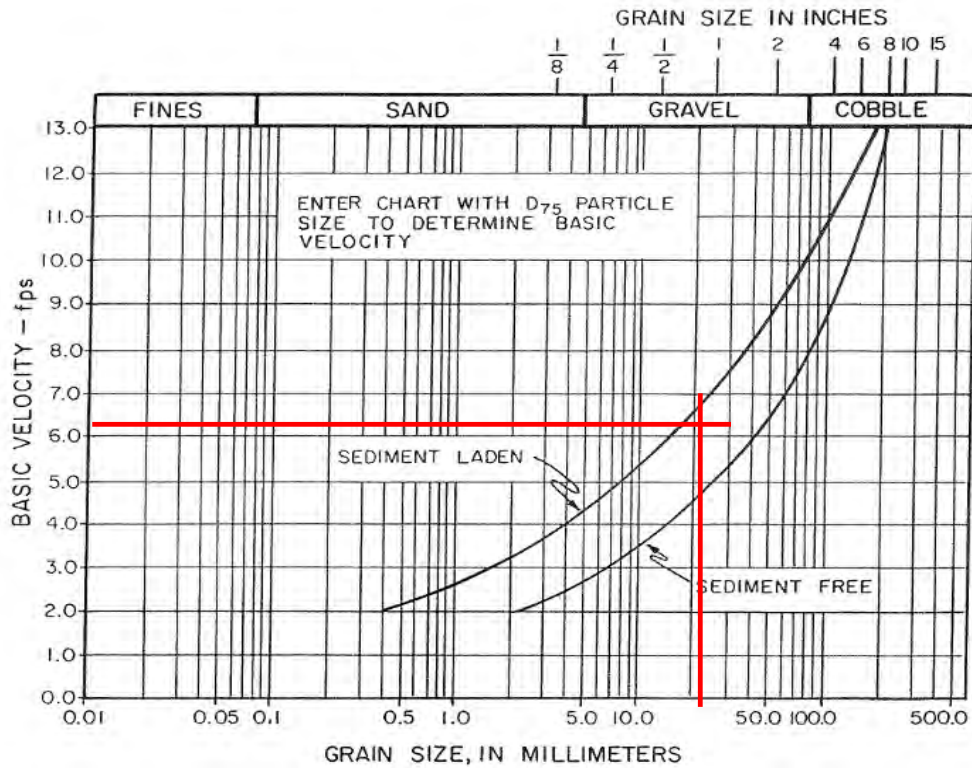
**Lateral Migration Setback Allowance for Riverine Floodplains
Level 2 Analysis**

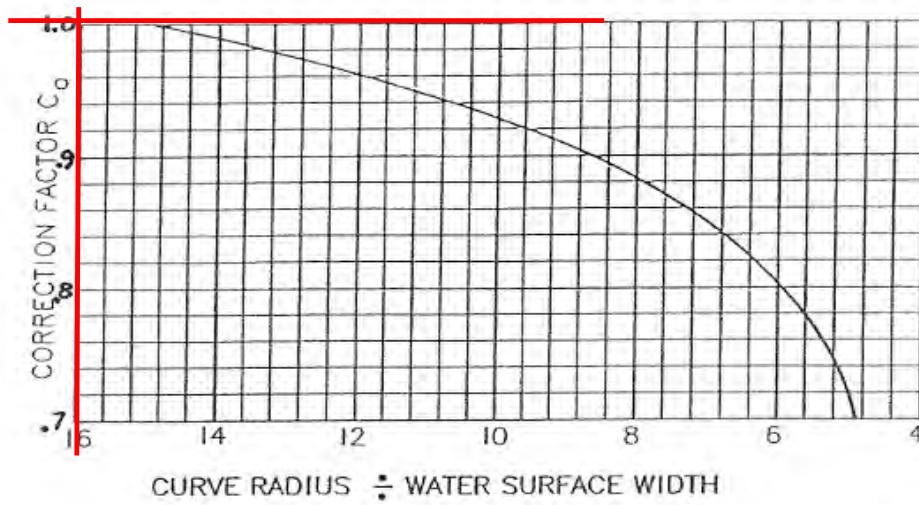
Cross Section 1572 - General Information

Bottom Width (b)	25.47 feet		
Side Slope (ft)	9.7 Horizontal	5.3 Vertical	
Channel Slope (S_c)	0.0012 feet/foot		
Radius of Curvature (r)	0 feet		
Water Surface Width	39.98 feet		
Average Manning's n	0.026		
Flow Depth (Y)	4.19 feet		
Flow Velocity (V)	3.48 feet/second		
D_{75}	19 mm	0.75 inches	0.062 feet
D_{65}	9.1 mm	0.36 inches	0.030 feet
D_{50}	5.2 mm	0.20 inches	0.017 feet

**Allowable Velocity Approach
(Assuming Sediment Laden Flow)**

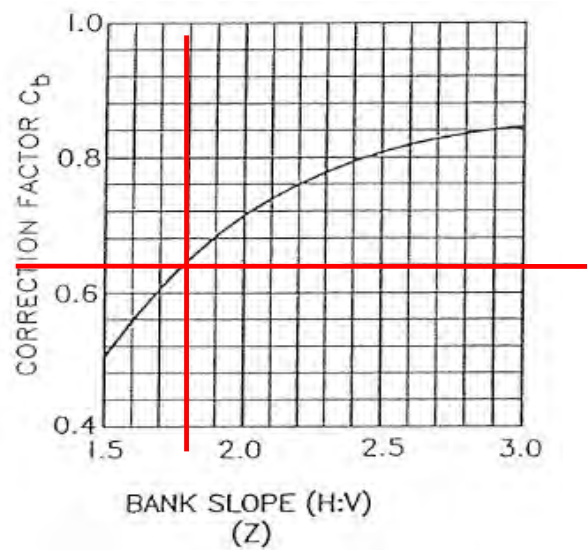
Base Allowable Velocity for Earth Channels V_b 6.3 feet/sec





Curve Radius / Water Surface Width

0.0

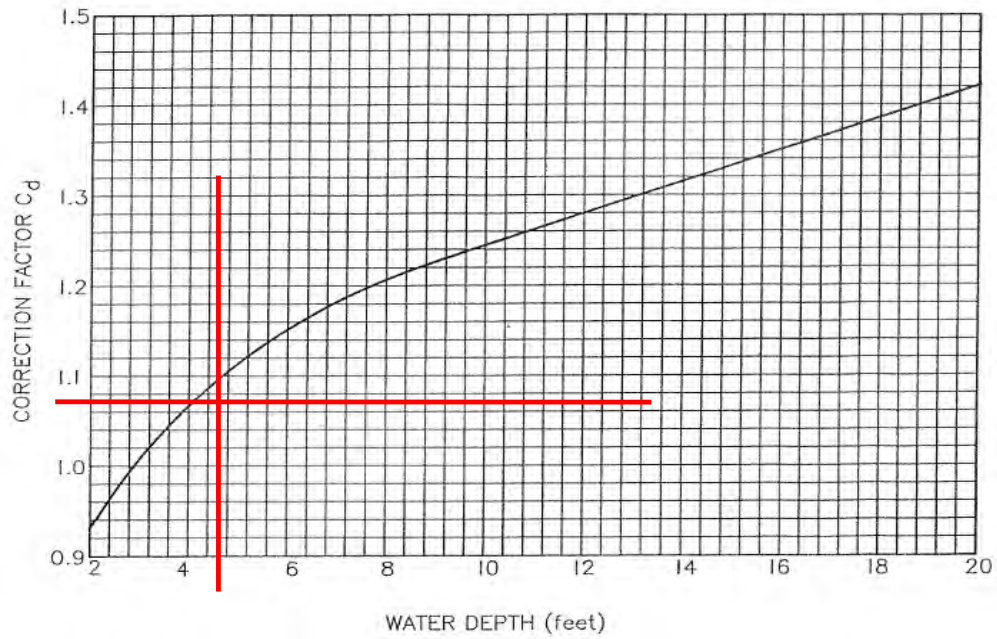


Horizontal/Vertical (Z)

1.83

Correction Factor C_d For Depth of Flow

1.07



Flow Depth (Y)

4.19 feet

Maximum Allowable Velocity

4.18

feet/second

$$V_a = V_b \times C_a \times C_b \times C_d$$

Comparison of Flow Velocity of the Channel to the Maximum Allowable Velocity

Maximum Allowable Velocity

4.18

feet/second

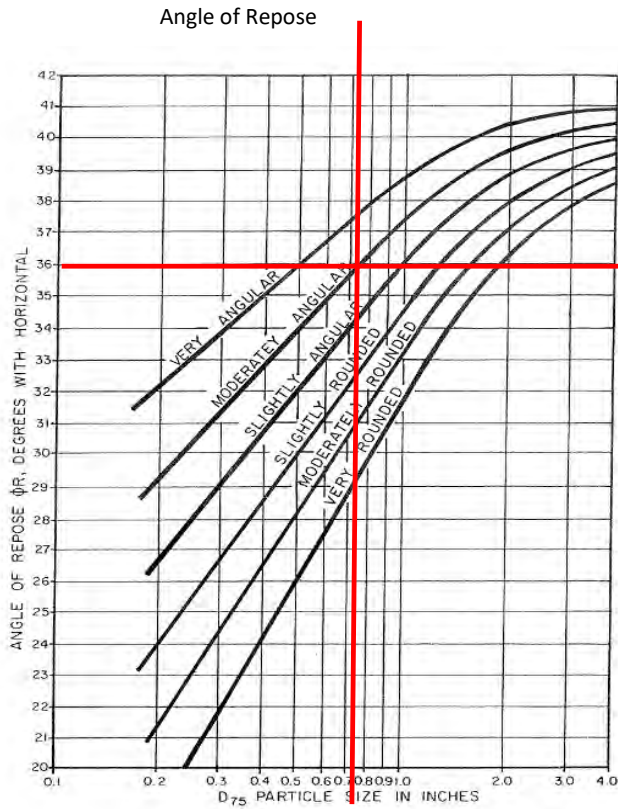
Flow Velocity

3.48

feet/second

Since the computed flow velocity is less than the maximum allowable velocity, erosion is not expected to occur.

Allowable Tractive Stress (τ_s)



Moderately Angular
 D_{75} 0.75 inches
 From Chart (ϕR) 36 Degrees

Solving for Allowable Tractive Stress

$$0.4 \left[\frac{Z^2 - \cot^2 \phi R}{1 + Z^2} \right]^{\frac{1}{2}} D_{75}$$

0.176 lbs/ft²

Allowable Tractive Stress, from calculation above 0.176 lb/ft²

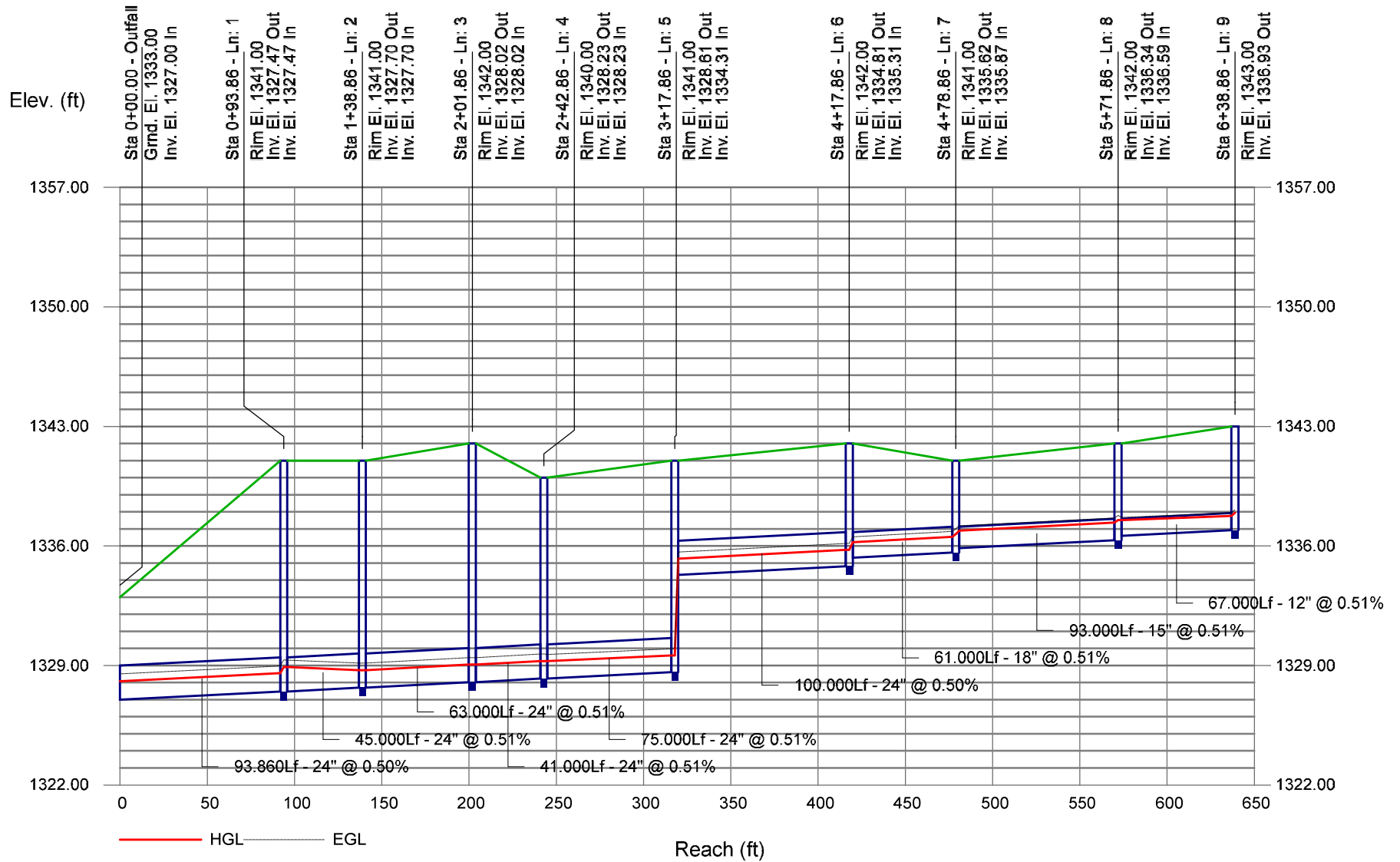
Calculated Tractive Stress, τ 0.09 lb/ft²

Since the allowable tractive stress is more than the calculated tractive stress, the channel is not erosive.



Appendix I – STORM DRAIN PROFILES

Storm Sewer Profile



Storm Sewer Inventory Report

Line No.	Alignment				Flow Data				Physical Data								Line ID
	Dnstr Line No.	Line Length (ft)	Defl angle (deg)	Junc Type	Known Q (cfs)	Drng Area (ac)	Runoff Coeff (C)	Inlet Time (min)	Invert El Dn (ft)	Line Slope (%)	Invert El Up (ft)	Line Size (in)	Line Shape	N Value (n)	J-Loss Coeff (K)	Inlet/ Rim El (ft)	
1	End	93.860	37.070	DrGrt	0.64	0.00	0.00	0.0	1327.00	0.50	1327.47	24	Cir	0.013	0.84	1341.00	
2	1	45.000	-30.321	DrGrt	0.01	0.00	0.00	0.0	1327.47	0.51	1327.70	24	Cir	0.013	1.48	1341.00	
3	2	63.000	-80.804	DrGrt	0.01	0.00	0.00	0.0	1327.70	0.51	1328.02	24	Cir	0.013	1.45	1342.00	
4	3	41.000	74.055	DrGrt	0.70	0.00	0.00	0.0	1328.02	0.51	1328.23	24	Cir	0.013	1.50	1340.00	
5	4	75.000	-90.000	DrGrt	0.32	0.00	0.00	0.0	1328.23	0.51	1328.61	24	Cir	0.013	0.50	1341.00	
6	5	100.000	-0.541	DrGrt	2.25	0.00	0.00	0.0	1334.31	0.50	1334.81	24	Cir	0.013	0.50	1342.00	
7	6	61.000	1.199	DrGrt	0.50	0.00	0.00	0.0	1335.31	0.51	1335.62	18	Cir	0.013	0.50	1341.00	
8	7	93.000	-0.049	DrGrt	2.20	0.00	0.00	0.0	1335.87	0.51	1336.34	15	Cir	0.013	0.50	1342.00	
9	8	67.000	0.259	DrGrt	2.40	0.00	0.00	0.0	1336.59	0.51	1336.93	12	Cir	0.013	1.00	1343.00	
Project File: Gold Dust Storm Drain.stm												Number of lines: 9			Date: 2/2/2023		

Storm Sewer Summary Report

Line No.	Line ID	Flow rate (cfs)	Line Size (in)	Line shape	Line length (ft)	Invert EL Dn (ft)	Invert EL Up (ft)	Line Slope (%)	HGL Down (ft)	HGL Up (ft)	Minor loss (ft)	HGL Junct (ft)	Dns Line No.	Junction Type
1		9.03	24	Cir	93.860	1327.00	1327.47	0.501	1328.08	1328.55	0.36	1328.91	End	DropGrate
2		8.39	24	Cir	45.000	1327.47	1327.70	0.511	1328.91	1328.73	n/a	1328.73	1	DropGrate
3		8.38	24	Cir	63.000	1327.70	1328.02	0.508	1328.73	1329.05	n/a	1329.05	2	DropGrate
4		8.37	24	Cir	41.000	1328.02	1328.23	0.512	1329.05	1329.26	n/a	1329.26	3	DropGrate
5		7.67	24	Cir	75.000	1328.23	1328.61	0.507	1329.26	1329.59	n/a	1329.59	4	DropGrate
6		7.35	24	Cir	100.000	1334.31	1334.81	0.500	1335.26	1335.77	n/a	1335.77	5	DropGrate
7		5.10	18	Cir	61.000	1335.31	1335.62	0.508	1336.22	1336.53	0.16	1336.69	6	DropGrate
8		4.60	15	Cir	93.000	1335.87	1336.34	0.505	1336.90	1337.37	0.14	1337.51	7	DropGrate
9		2.40	12	Cir	67.000	1336.59	1336.93	0.508	1337.51	1337.76	0.18	1337.95	8	DropGrate

Project File: Gold Dust Storm Drain.stm	Number of lines: 9	Run Date: 2/2/2023
---	--------------------	--------------------

NOTES: Known Qs only

Storm Sewer Tabulation

Station		Len (ft)	Drng Area		Rnoff coeff (C)	Area x C		Tc		Rain (l) (in/hr)	Total flow (cfs)	Cap full (cfs)	Vel (ft/s)	Pipe		Invert Elev		HGL Elev		Grnd / Rim Elev		Line ID
Line	To Line		Incr (ac)	Total (ac)		Incr	Total	Inlet (min)	Syst (min)					Size (in)	Slope (%)	Dn (ft)	Up (ft)	Dn (ft)	Up (ft)	Dn (ft)	Up (ft)	
1	End	93.860	0.00	0.00	0.00	0.00	0.00	0.0	3.3	0.0	9.03	16.00	5.23	24	0.50	1327.00	1327.47	1328.08	1328.55	0.00	1341.00	
2	1	45.000	0.00	0.00	0.00	0.00	0.00	0.0	3.0	0.0	8.39	16.17	4.31	24	0.51	1327.47	1327.70	1328.91	1328.73	1341.00	1341.00	
3	2	63.000	0.00	0.00	0.00	0.00	0.00	0.0	2.6	0.0	8.38	16.12	5.13	24	0.51	1327.70	1328.02	1328.73	1329.05	1341.00	1342.00	
4	3	41.000	0.00	0.00	0.00	0.00	0.00	0.0	2.4	0.0	8.37	16.19	5.13	24	0.51	1328.02	1328.23	1329.05	1329.26	1342.00	1340.00	
5	4	75.000	0.00	0.00	0.00	0.00	0.00	0.0	1.8	0.0	7.67	16.10	4.84	24	0.51	1328.23	1328.61	1329.26	1329.59	1340.00	1341.00	
6	5	100.000	0.00	0.00	0.00	0.00	0.00	0.0	1.1	0.0	7.35	15.99	4.95	24	0.50	1334.31	1334.81	1335.26	1335.77	1341.00	1342.00	
7	6	61.000	0.00	0.00	0.00	0.00	0.00	0.0	0.8	0.0	5.10	7.49	4.55	18	0.51	1335.31	1335.62	1336.22	1336.53	1342.00	1341.00	
8	7	93.000	0.00	0.00	0.00	0.00	0.00	0.0	0.4	0.0	4.60	4.59	4.26	15	0.51	1335.87	1336.34	1336.90	1337.37	1341.00	1342.00	
9	8	67.000	0.00	0.00	0.00	0.00	0.00	0.0	0.0	0.0	2.40	2.54	3.31	12	0.51	1336.59	1336.93	1337.51	1337.76	1342.00	1343.00	

Project File: Gold Dust Storm Drain.stm

Number of lines: 9

Run Date: 2/2/2023

NOTES: Known Qs only ; c = cir e = ellip b = box

Line No.	Area Dn (sqft)	Area Up (sqft)	Byp Ln No	Coeff C1 (C)	Coeff C2 (C)	Coeff C3 (C)	Capac Full (cfs)	Crit Depth (ft)	Cross SI, Sw (ft/ft)	Cross SI, Sx (ft/ft)	Curb Len (ft)	Defl Ang (Deg)	Depth Dn (ft)	Depth Up (ft)	DnStm Ln No	Drng Area (ac)	Easting X (ft)	EGL Dn (ft)	EGL Up (ft)	Energy Loss (ft)
1	1.71	1.72	Sag	0.20	0.50	0.90	16.00	1.07	0.050	0.020	37.070	1.08	1.08**	Outfall	0.00	264.55	1328.50	1328.97	0.465
2	1.63	1.63	1	0.20	0.50	0.90	16.17	1.03	0.050	0.020	-30.321	1.44	1.03**	1	0.00	309.23	1329.32	1329.14	0.000
3	1.63	1.63	2	0.20	0.50	0.90	16.12	1.03	0.050	0.020	-80.804	1.03	1.03**	2	0.00	326.54	1329.14	1329.46	0.000
4	1.63	1.63	3	0.20	0.50	0.90	16.19	1.03	0.050	0.020	74.055	1.03	1.03**	3	0.00	367.54	1329.46	1329.67	0.000
5	1.54	1.54	4	0.20	0.50	0.90	16.10	0.98	0.050	0.020	-90.000	1.03	0.98**	4	0.00	367.54	1329.65	1329.98	0.000
6	1.48	1.50	5	0.20	0.50	0.90	15.99	0.96	0.050	0.020	-0.541	0.95	0.96**	5	0.00	366.60	1335.64	1336.15	0.000
7	1.12	1.12	6	0.20	0.50	0.90	7.49	0.87	0.050	0.020	1.199	0.91	0.91	6	0.00	367.30	1336.54	1336.85	0.309
8	1.08	1.08	7	0.20	0.50	0.90	4.59	0.87	0.050	0.020	-0.049	1.03	1.03	7	0.00	368.29	1337.18	1337.65	0.469
9	0.76	0.70	8	0.20	0.50	0.90	2.54	0.66	0.050	0.020	0.259	0.92	0.83	8	0.00	369.30	1337.67	1337.95	0.280

Project File: Gold Dust Storm Drain.stm	Number of lines: 9	Date: 2/2/2023
---	--------------------	----------------

NOTES: ** Critical depth

MyReport

Flow Rate	Sf Ave	Sf Dn	Grate Area	Grate Len	Grate Width	Gnd/Rim El Dn	Gnd/Rim El Up	Gutter Depth	Gutter Slope	Gutter Spread	Gutter Width	HGL Dn	HGL Up	HGL Jnct	HGL Jmp Dn	HGL Jmp Up	Incr CxA	Incr Q	Inlet Depth	Inlet Eff
(cfs)	(ft/ft)	(ft/ft)	(sqft)	(ft)	(ft)	(ft)	(ft)	(ft)	(ft/ft)	(ft)	(ft)	(ft)	(ft)	(ft)	(ft)	(ft)		(cfs)	(ft)	(%)
9.03	0.496	0.493	2.00	2.00	2.00	0.00	1341.00	0.09	Sag	10.92	2.00	1328.08	1328.55	1328.91	0.00	0.64	0.09	100
8.39	0.000	0.000	2.00	2.00	2.00	1341.00	1341.00	0.01	Sag	2.56	2.00	1328.91	1328.73	1328.73	0.00	0.01	0.01	100
8.38	0.000	0.000	2.00	2.00	2.00	1341.00	1342.00	0.01	Sag	2.56	2.00	1328.73	1329.05	1329.05	0.00	0.01	0.01	100
8.37	0.000	0.000	2.00	2.00	2.00	1342.00	1340.00	0.09	Sag	11.46	2.00	1329.05	1329.26	1329.26	0.00	0.70	0.09	100
7.67	0.000	0.000	2.00	2.00	2.00	1340.00	1341.00	0.06	Sag	7.61	2.00	1329.26	1329.59	1329.59	0.00	0.32	0.06	100
7.35	0.000	0.000	2.00	2.00	2.00	1341.00	1342.00	0.21	Sag	22.62	2.00	1335.26	1335.77	1335.77	0.00	2.25	0.21	100
5.10	0.507	0.507	2.00	2.00	2.00	1342.00	1341.00	0.08	Sag	9.56	2.00	1336.22	1336.53	1336.69	0.00	0.50	0.08	100
4.60	0.505	0.505	2.00	2.00	2.00	1341.00	1342.00	0.20	Sag	22.31	2.00	1336.90	1337.37	1337.51	0.00	2.20	0.20	100
2.40	0.418	0.394	2.00	2.00	2.00	1342.00	1343.00	0.22	Sag	23.53	2.00	1337.51	1337.76	1337.95	0.00	2.40	0.22	100

Project File: Gold Dust Storm Drain.stm

Number of lines: 9

Date: 2/2/2023

NOTES: ** Critical depth

Line Length	Line Size	Line Slope	Line Type	Local Depr	n-val Gutter	n-val Pipe	Minor Loss	Northing Y	Pipe Travel	Q Byp	Q Capt	Q Carry	Line Rise	Runoff Coeff	Line Span	Area A1	Area A2	Area A3	Tc	Throat Ht	Total Area	Total CxA
(ft)	(in)	(%)		(in)			(ft)	(ft)	(min)	(cfs)	(cfs)	(cfs)	(in)	(C)	(in)	(ac)	(ac)	(ac)	(min)	(in)	(ac)	
93.860	24	0.50	Cir	0.013	0.36	82.24	0.54	0.00	0.64	0.00	24	0.00	24	0.00	0.00	0.00	3.3	0.00	0.00
45.000	24	0.51	Cir	0.013	n/a	76.95	0.28	0.00	0.01	0.00	24	0.00	24	0.00	0.00	0.00	3.0	0.00	0.00
63.000	24	0.51	Cir	0.013	n/a	137.52	0.39	0.00	0.01	0.00	24	0.00	24	0.00	0.00	0.00	2.6	0.00	0.00
41.000	24	0.51	Cir	0.013	n/a	137.52	0.26	0.00	0.70	0.00	24	0.00	24	0.00	0.00	0.00	2.4	0.00	0.00
75.000	24	0.51	Cir	0.013	n/a	212.52	0.51	0.00	0.32	0.00	24	0.00	24	0.00	0.00	0.00	1.8	0.00	0.00
100.000	24	0.50	Cir	0.013	n/a	312.52	0.71	0.00	2.25	0.00	24	0.00	24	0.00	0.00	0.00	1.1	0.00	0.00
61.000	18	0.51	Cir	0.013	0.16	373.52	0.35	0.00	0.50	0.00	18	0.00	18	0.00	0.00	0.00	0.8	0.00	0.00
93.000	15	0.51	Cir	0.013	0.14	466.51	0.41	0.00	2.20	0.00	15	0.00	15	0.00	0.00	0.00	0.4	0.00	0.00
67.000	12	0.51	Cir	0.013	0.18	533.50	0.37	0.00	2.40	0.00	12	0.00	12	0.00	0.00	0.00	0.0	0.00	0.00

Project File: Gold Dust Storm Drain.stm Number of lines: 9 Date: 2/2/2023

NOTES: ** Critical depth

Hydraulic Grade Line Computations

Line (1)	Size (in) (2)	Q (cfs) (3)	Downstream								Len (ft) (12)	Upstream								Check		JL coeff (K) (23)	Minor loss (ft) (24)
			Invert elev (ft) (4)	HGL elev (ft) (5)	Depth (ft) (6)	Area (sqft) (7)	Vel (ft/s) (8)	Vel head (ft) (9)	EGL elev (ft) (10)	Sf (%) (11)		Invert elev (ft) (13)	HGL elev (ft) (14)	Depth (ft) (15)	Area (sqft) (16)	Vel (ft/s) (17)	Vel head (ft) (18)	EGL elev (ft) (19)	Sf (%) (20)	Ave Sf (%) (21)	Enrgy loss (ft) (22)		
1	24	9.03	1327.00	1328.08	1.08	1.71	5.22	0.42	1328.50	0.493	93.860	1327.47	1328.55	1.08**	1.72	5.24	0.43	1328.97	0.498	0.496	0.465	0.84	0.36
2	24	8.39	1327.47	1328.91	1.44	1.63	3.48	0.41	1329.32	0.000	45.000	1327.70	1328.73	1.03**	1.63	5.14	0.41	1329.14	0.000	0.000	n/a	1.48	n/a
3	24	8.38	1327.70	1328.73	1.03	1.63	5.13	0.41	1329.14	0.000	63.000	1328.02	1329.05	1.03**	1.63	5.13	0.41	1329.46	0.000	0.000	n/a	1.45	n/a
4	24	8.37	1328.02	1329.05	1.03	1.63	5.13	0.41	1329.46	0.000	41.000	1328.23	1329.26	1.03**	1.63	5.13	0.41	1329.67	0.000	0.000	n/a	1.50	n/a
5	24	7.67	1328.23	1329.26	1.03	1.54	4.70	0.39	1329.65	0.000	75.000	1328.61	1329.59	0.98**	1.54	4.98	0.39	1329.98	0.000	0.000	n/a	0.50	n/a
6	24	7.35	1334.31	1335.26	0.95*	1.48	4.98	0.38	1335.64	0.000	100.000	1334.81	1335.77	0.96**	1.50	4.92	0.38	1336.15	0.000	0.000	n/a	0.50	n/a
7	18	5.10	1335.31	1336.22	0.91*	1.12	4.55	0.32	1336.54	0.507	61.000	1335.62	1336.53	0.91	1.12	4.55	0.32	1336.85	0.507	0.507	0.309	0.50	0.16
8	15	4.60	1335.87	1336.90	1.03*	1.08	4.26	0.28	1337.18	0.505	93.000	1336.34	1337.37	1.03	1.08	4.26	0.28	1337.65	0.504	0.505	0.469	0.50	0.14
9	12	2.40	1336.59	1337.51	0.92	0.76	3.18	0.16	1337.67	0.394	67.000	1336.93	1337.76	0.83	0.70	3.44	0.18	1337.95	0.442	0.418	0.280	1.00	0.18

Project File: Gold Dust Storm Drain.stm

Number of lines: 9

Run Date: 2/2/2023

Notes: * Normal depth assumed; ** Critical depth. ; c = cir e = ellip b = box

General Procedure:

Hydraflow computes the HGL using the Bernoulli energy equation. Manning's equation is used to determine energy losses due to pipe friction. In a standard step, iterative procedure, Hydraflow assumes upstream HGLs until the energy equation balances. If the energy equation cannot balance, supercritical flow exists and critical depth is temporarily assumed at the upstream end. A supercritical flow Profile is then computed using the same procedure in a downstream direction using momentum principles.

Col. 1 The line number being computed. Calculations begin at Line 1 and proceed upstream.

Col. 2 The line size. In the case of non-circular pipes, the line rise is printed above the span.

Col. 3 Total flow rate in the line.

Col. 4 The elevation of the downstream invert.

Col. 5 Elevation of the hydraulic grade line at the downstream end. This is computed as the upstream HGL + Minor loss of this line's downstream line.

Col. 6 The downstream depth of flow inside the pipe (HGL - Invert elevation) but not greater than the line size.

Col. 7 Cross-sectional area of the flow at the downstream end.

Col. 8 The velocity of the flow at the downstream end, (Col. 3 / Col. 7).

Col. 9 Velocity head (Velocity squared / 2g).

Col. 10 The elevation of the energy grade line at the downstream end, HGL + Velocity head, (Col. 5 + Col. 9).

Col. 11 The friction slope at the downstream end (the S or Slope term in Manning's equation).

Col. 12 The line length.

Col. 13 The elevation of the upstream invert.

Col. 14 Elevation of the hydraulic grade line at the upstream end.

Col. 15 The upstream depth of flow inside the pipe (HGL - Invert elevation) but not greater than the line size.

Col. 16 Cross-sectional area of the flow at the upstream end.

Col. 17 The velocity of the flow at the upstream end, (Col. 3 / Col. 16).

Col. 18 Velocity head (Velocity squared / 2g).

Col. 19 The elevation of the energy grade line at the upstream end, HGL + Velocity head, (Col. 14 + Col. 18) .

Col. 20 The friction slope at the upstream end (the S or Slope term in Manning's equation).

Col. 21 The average of the downstream and upstream friction slopes.

Col. 22 Energy loss. Average $Sf/100 \times \text{Line Length}$ (Col. 21/100 x Col. 12). Equals (EGL upstream - EGL downstream) +/- tolerance.

Col. 23 The junction loss coefficient (K).

Col. 24 Minor loss. (Col. 23 x Col. 18). Is added to upstream HGL and used as the starting HGL for the next upstream line(s).