



GOLD DUST APARTMENTS

Preliminary Drainage Report

Prepared For: ESG Architecture & Design

April 17, 2023

DIBBLE

1122028

GOLD DUST APARTMENTS

Preliminary Drainage Report

10050 N Scottsdale Road, Paradise Valley, AZ

1122028

Prepared For: ESG Architecture & Design
Maria Ambrose
ESG Architecture & Design
500 S Washington Ave #1080
Minneapolis, MN 55415

April 17, 2023

Josh Papworth, PE
Senior Engineer

Dibble & Associates Consulting Engineers, Inc., dba Dibble





Table of Contents

| | |
|---|----|
| 1. INTRODUCTION..... | 2 |
| 1.1 PURPOSE..... | 2 |
| 1.2 STUDY AREA..... | 2 |
| 2. EXISTING CONDITIONS | 3 |
| 2.1 ON-SITE..... | 3 |
| 2.2 OFF-SITE | 3 |
| 3. DESIGN CRITERIA..... | 3 |
| 3.1 ON-SITE RAINFALL DEPTH | 3 |
| 3.2 ON-SITE RAINFALL INTENSITY | 3 |
| 3.3 ON-SITE RUNOFF COEFFICIENT | 4 |
| 4. STUDY APPROACH | 4 |
| 4.1 ON-SITE HYDROLOGY & HYDRAULICS..... | 4 |
| 4.2 OFF-SITE HYDROLOGY | 5 |
| 4.3 OFF-SITE HYDRAULICS | 6 |
| 4.4 OFF-SITE SCOUR & LATERAL MIGRATION POTENTIAL..... | 7 |
| 5. PROPOSED DRAINAGE CONDITIONS | 8 |
| 5.1 ON-SITE..... | 8 |
| 5.2 MAINTENANCE PLAN..... | 9 |
| 5.3 FINISHED FLOORS..... | 9 |
| 5.4 OFF-SITE | 9 |
| 6. CONCLUSIONS | 10 |
| 7. REFERENCES | 10 |

List of Figures

| | |
|---|---|
| Figure 1 – VICINITY MAP | 2 |
| Figure 2 – OFFSITE HYDROLOGY RESULTS..... | 6 |

List of Tables

| | |
|---|---|
| Table 1 – MANNING’S N VALUES..... | 7 |
| Table 2 – UNNAMED CHANNEL MIGRATION POTENTIAL SUMMARY | 7 |
| Table 3 - PROPOSED DRAINAGE VOLUME SUMMARY | 9 |

List of Equations

| | |
|--|---|
| Equation 1 – RATIONAL METHOD..... | 4 |
| Equation 2 – REQUIRED FIRST FLUSH RETENTION VOLUME | 4 |
| Equation 3 – STORM DRAIN OUTLET CAPACITY | 4 |
| Equation 4 – BLEED OFF TIME..... | 5 |
| Equation 5 – TOTAL SCOUR..... | 7 |

Appendices

| | |
|--|---|
| Appendix A – PRELIMINARY GRADING AND DRAINAGE PLAN..... | A |
| Appendix B – FEMA FIRMETTE MAP | B |
| Appendix C – NOAA ATLAS PRECIPITATION DATA | C |
| Appendix D – DETAILED DRAINAGE CALCULATIONS..... | D |
| Appendix E – UNNAMED CHANNEL FIELD PHOTOGRAPHS | E |
| Appendix F – OFF-SITE HYDROLOGY RESULTS (LARGE FORMAT) | F |
| Appendix G – UNNAMED CHANNEL HYDRAULIC COMPUTATIONS..... | G |
| Appendix H – SCOUR AND LATERAL MIGRATION POTENTIAL CALCULATIONS..... | H |
| Appendix I – STORM DRAIN PROFILES | I |

1. INTRODUCTION

This report presents a preliminary drainage plan for the City of Scottsdale as a part of the Gold Dust Apartments project. The Gold Dust Apartments site is approximately 4.8 acres and fully developed. There is an existing wash on the west limit of the site. The project proposes a new mixed-use building and associated utility and hardscape improvements. This report presents the drainage analysis and results for the project.

The project is in the northeast quadrant of Township 3 North, Range 4 East, Section 27 and has an Assessor’s Parcel Number (APN) of 175-56-002H. See **Figure 1** for a location map.

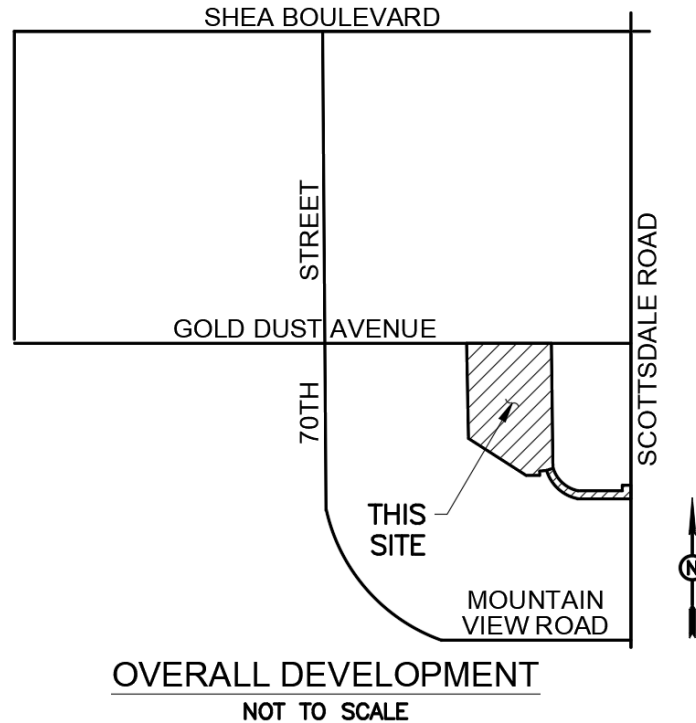


Figure 1 – VICINITY MAP

1.1 PURPOSE

The drainage analysis and design documented herein supports the zoning submittal for the ultimate buildout of Gold Dust Apartments. The design will provide drainage infrastructure to meet the City of Scottsdale and the Flood Control District of Maricopa County requirements for stormwater protection and floodplain management.

1.2 STUDY AREA

The Gold Dust Apartments project is bounded by a wash to the west of the site, existing infrastructure to the east of the site, Gold Dust Avenue to the north of the site, and residential apartment buildings to the south. On-site improvements planned for this 4.8-acre site include extensions of an existing building, hardscape improvements, and associated utility and drainage improvements, which will be discussed within this report.

2. EXISTING CONDITIONS

This site is in a FEMA Zone 'X', as defined as "Areas of 0.2% annual chance flood; areas of 1% annual chance flood with average depth less than 1 foot or areas less than 1 square mile; and areas protected by levees from 1% annual chance flood." This hazard designation is considered minimal, and flood insurance is not federally mandated. The FEMA Flood Insurance Rate (FIRM) panel for this area is provided in **Appendix B**.

2.1 ON-SITE

Currently this site is a 4.8-acre parcel that is fully developed and uses most of its land use on an existing building and parking lot. The site is generally flat with an existing wash on the west side of the site. This wash runs the entire west side of the parcel as it forces water travel from north to south. The existing surface forces water runoff to run from the northeast to the southwest of the site. There is an existing 24-inch storm drain on the southwest side of the building. This storm drain exports water straight into the existing wash that is located on the west end of the site. There is a 12-inch storm drain on the west side of the building. This storm drain also exports water straight into the existing wash that is located on the west side of the site. The existing building had three different elevations within the building as stairs led up to different sections of the building. The finished floor elevations are 1342.48 in the north end of the building, 1341.68 in the middle section of the building and 1340.78 at the southernmost end of the building. The ultimate site outfall is located at the southwestern edge of the site in the existing wash at an elevation of 1335.16.

2.2 OFF-SITE

An unnamed channel exists along the western property boundary of the site. The channel extends approximately 1000 feet downstream of the site where it joins a channel at Mountain View Road, ultimately emptying to Indian Bend Wash. The channel was designed as part of previous adjacent development and consists of a partially natural bed and banks with areas of riprap erosion control and grass and desert landscaped bank lining. As-built plans date the original channel construction as 1984, and historical aerial photography supports that modifications resulting in its current configuration took place as late as 1996. A field investigation of the wash was conducted by Dibble engineers on July 12, 2022. The wash showed few signs of instability with intermittent areas of local scour. Local scour appeared to be limited to culvert outlets and at the toes of bends on the west bank. Selected field photographs of the channel can be found in **Appendix E**.

3. DESIGN CRITERIA

The project is designed consistent with standards set forth in the City of Scottsdale (*DS&PM*) and the Flood Control District of Maricopa County (FDCMC) Drainage Design Manual for Maricopa Count Volume I Hydrology (2018) and Volume II Hydraulics (2018) with exceptions noted herein.

Examples of specific design criteria for various design elements are provided in the following sections.

3.1 ON-SITE RAINFALL DEPTH

Rainfall depth was determined to be 0.5 inches based on the first flush retention requirement for the project.

3.2 ON-SITE RAINFALL INTENSITY

Rainfall intensities of 4.73 inches and 7.48 inches were used to analyze the capacity of the proposed system based on the 10 year, 5-min storm and the 100-year, 5-min storm respectively. Rainfall precipitation values were obtained directly from the NOAA Atlas 14 Precipitation Data Frequency Server. NOAA Atlas 14 rainfall intensities may be found in **Appendix C**.

3.3 ON-SITE RUNOFF COEFFICIENT

The existing site may be categorized as being fully developed with parking lot, hardscape, and structures. The runoff coefficient for paved streets, parking lots, roofs and driveways shall be 0.95, as defined by the city. For areas using desert landscaping a runoff coefficient of 0.45, as defined by the city.

4. STUDY APPROACH

4.1 ON-SITE HYDROLOGY & HYDRAULICS

Stormwater will be collected for storm drain conveyance via combination of roof drains and surface inline storm drain inlets. Drainage areas are shown on the Preliminary Grading and Drainage Plan in **Appendix A**. Surface inlets are provided to capture runoff generated from the landscape/hardscape areas. The minimum grated area opening is 24 inches. Roof drain connections are planned to convey stormwater runoff to the storm drain pipe and to the underground retention tanks, then ultimately to the existing wash. The peak flow for each inlet was calculated with **Equation 1** below.

Equation 1 – RATIONAL METHOD

$$Q = CiA$$

Q = peak discharge (cubic feet per second)

C = runoff coefficient

I = average rainfall intensity (inch/hour) for duration Tc (5 minutes minimum)

A = drainage area (acres)

The pre vs post volumes were calculated for the project site, and the first flush volume was greater. The proposed onsite StormCapture retention tanks are concrete and are designed to store the first flush as required by the DS&PM. A Maxwell Plus dual chamber drywell is planned to dissipate basin storm water within 36 hours. The required first flush retention volume was determined by using **Equation 2**, and these calculations can be reviewed in **Appendix D**.

Equation 2 – REQUIRED FIRST FLUSH RETENTION VOLUME

$$V_R = 1 \left(\frac{P}{12} \right) A,$$

V_R = retention volume required (cubic feet)

P = 0.5 (inch), per City of Scottsdale

A = area of project, (square feet)

Storm drain outlet capacity was calculated using **Equation 3** below, the overflow pipe to the wash will have a backwater valve to prevent water from the wash from entering the retention chamber. See **Appendix D** for provided retention volume calculations.

Equation 3 – STORM DRAIN OUTLET CAPACITY

$$Q = \left(\frac{1.49}{n} \right) * AR^{0.67} S^{0.5}$$

Q = flow rate (cubic feet per second)

A = flow area (square feet)

R = hydraulic radius (feet)

S = slope (feet/feet)

n = manning's number

Bleed off time was calculated using **Equation 4** below. See **Appendix D** for provided retention volume calculations.

Equation 4 – BLEED OFF TIME

$$t = \left(\frac{V_R}{Q} \right) / \frac{1 \text{ hour}}{3600 \text{ s}}$$

t = bleed off time (hours)

A = retention volume provided (cubic feet)

Q = flow rate (cubic feet per second) from outlet pipe or drywell (0.1 CFS [Minimum rate per MCFCD])

4.2 OFF-SITE HYDROLOGY

The unnamed wash at the western property boundary is within the *East Shea Area Drainage Master Study/Plan* (ADMS/P) project area. A previous study, the *Lower Indian Bend Wash Area Drainage Master Study* (ADMS) included the area of the project site as well; however, the area was considered a buffer area for flow exchanged between low-resolution modeling areas and focused modeling areas. Therefore, use of the results in the buffer were advised to be used with caution, and Dibble has decided to make use of the more recent East Shea ADMS/P modeling. As of the writing of this report, all components of the East Shea ADMS modeling are complete, the models have completed multiple rounds of review by the Flood Control District of Maricopa County (FCDMC), and the hydrology is in a final review stage. For this project, Dibble has been provided the ADMS's 2-dimensional hydrology models, reviewed the models for appropriateness in the context of the Gold Dust Apartments project, and adopted them for use. All modeling for use in establishing peak discharges at the Gold Dust Apartments site is being submitted under this report's seal.

The area was modeling using the Professional Version of FLO-2D (FLO-2D PRO) (FLO-2D Software, Inc., 2018), Build No. 19.07.21, having an executable date of March 20, 2020. Dibble created a 100-year, 6-hour version of the model to ensure the greater of the 24-hour and 6-hour storm results are used for analysis and design of the unnamed wash on the site. The project is within Subdomain 1 of the East Shea ADMS/P model area and the 6-hour storm duration was found to produce the highest 100-year peak discharges at the site. **Figure 2** provides maximum depth results and peak discharges at the project site. **Exhibit F-1** in **Appendix F** provides results for all of Subdomain 1. Additional supporting documentation of the FLO-2D modeling parameters is provided with the electronic data for this report.

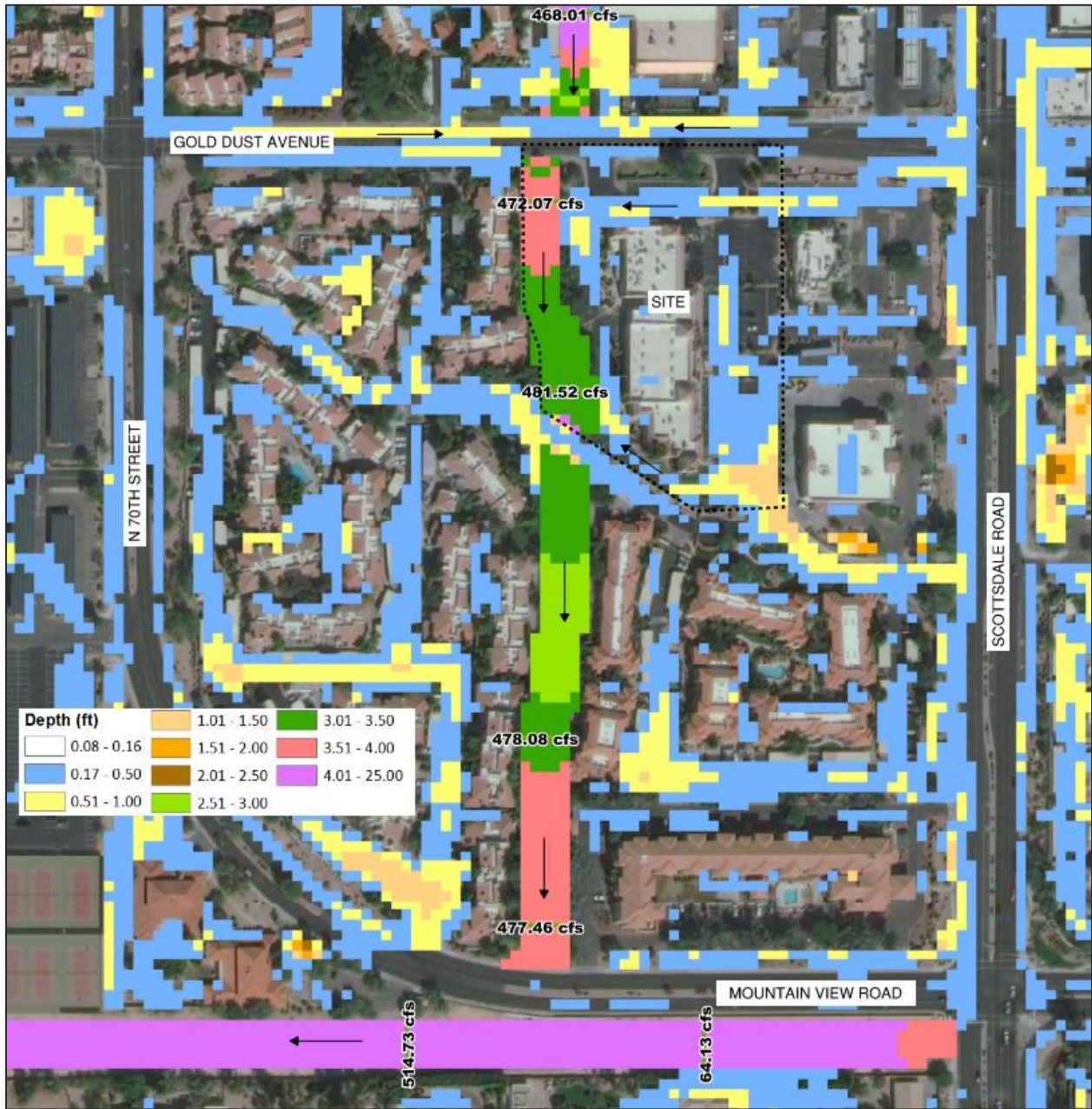


Figure 2 – OFFSITE HYDROLOGY RESULTS

4.3 OFF-SITE HYDRAULICS

Detailed, one-dimensional hydraulic modeling of the unnamed channel at the site was performed using GeoHEC-RAS v.3.1.0 software. Hydraulic modeling provided the existing condition and post-project water surface elevations at the site boundary and basis of scour and lateral migration potential computations.

Hydraulic modeling made use of field survey of the wash obtained in October of 2021. Field survey was supplemented for reaches upstream and downstream of the project site with Quality Level 1 LiDAR data, sampled to a 1/2 meter digital elevation model, obtained from the United States Geological Survey. Elevations provided herein are on NAVD 88 vertical datum.

Post-project hydraulic modeling included modification of cross sections for the proposed bank grading and Manning’s roughness values were modified to represent the proposed riprap lining.

Table 1 provides Manning’s n values selected for hydraulic modeling.

Table 1 – MANNING’S N VALUES

| Ground Feature | Manning’s N Value |
|-------------------------------|-------------------|
| Shotcrete Lining | 0.019 |
| Wash Bed | 0.035-0.040 |
| Wash Bank – Grass Landscaping | 0.035 |
| Wash Bank - Vegetated | 0.04-0.05 |
| Riprap Lining (D50=4”) | 0.040 |

Hydraulic modeling results, including water surface profiles, can be found in **Appendix G**. Water surface elevations at selected locations are provided on the Preliminary Grading and Drainage Plan.

4.4 OFF-SITE SCOUR & LATERAL MIGRATION POTENTIAL

The potential for lateral erosion at the east bank of the unnamed channel was performed in a spreadsheet and followed methodology provided in Arizona Department of Water Resources (ADWR) *State Standard Attachment 5-96 Watercourse Sediment Balance* (SSA 5-96). Bed and bank sediment samples were analyzed to provide gradations. Level II analyses were performed for both the bed and bank gradation data at each HEC-RAS cross section fronting the site. The more conservative of the results of both were used as the basis for erodibility. These calculations can be found in **Appendix H**. A summary of the erodibility estimate results are provided in **Table 2** below. Level II analysis guidance states that if either the allowable velocity or tractive stress analysis approach support a non-erosive result, the channel may be considered non-erosive. These results support that an approximately 150-foot length of the existing channel, beginning at the downstream end of an existing concrete access ramp and extending south, is potentially erosive and has lateral migration potential during the peak of the 100-year storm event.

Table 2 – UNNAMED CHANNEL MIGRATION POTENTIAL SUMMARY

| HEC-RAS CROSS SECTION | SS 5-96 LEVEL II APPROACH | |
|-----------------------|---------------------------|--------------------------|
| | ALLOWABLE VELOCITY | TRACTIVE STRESS ANALYSIS |
| 1572 | Erosive | Not Erosive |
| 1496 | Erosive | Erosive |
| 1422 | Erosive | Erosive |
| 1319 | Erosive | Erosive |
| 1223 | Erosive | Not Erosive |
| 1193 | Not Erosive | Not Erosive |

Scour calculations were performed using post-project HEC-RAS modeling results and wash bed sample gradation. The analysis included the summation of several scour components. The following equation was used to estimate the total scour.

Equation 5 – TOTAL SCOUR

$$Z_t = FS * (Z_{\text{long-term}} + Z_{\text{general}} + Z_{\text{bend}} + Z_{\text{bedform}} + Z_{\text{low flow}} + Z_{\text{local}})$$

Where Z_t is the total design scour and FS is the factor of safety. A FS of 1.3 has been used for this condition.

Long-term scour, $Z_{\text{long-term}}$, is an estimation of the ultimate degradation of movable channel beds as they seek an equilibrium sediment transport condition. The reach is protected from long-term scour by the concrete box culvert at its downstream end. This hard point cuts off progression of long-term degradation. Also, the existing bed slope is nearly 0%. For these reasons, a value of zero was used for the long-term scour component.

General scour, Z_{general} , is the component of scour that represents the mobile portion of the bed-material of the channel bottom during the peak flow event. General scour was computed using the Blanch Equation, which is well suited to channels in which there is little or no sediment supply from the upstream reach. Upstream of Gold Dust Avenue, the wash is completely channelized with a concrete lining.

Bend scour, Z_{bend} , occurs on the outside of bends in the wash channel. The Blanch Equation for general scour accounts for a moderate bend. Therefore, this value was set to zero.

Bedform scour, Z_{bedform} , also known as dune and anti-dune scour is the component of scour caused by movement of dune shaped bed forms along the bottom of the channel and is primarily confined to sand bed washes. The bedform scour component was estimated by calculating both dune and anti-dune scour. The actual type of bedform present is a function of the flow regime. Since the flow regime may change with the fluctuating discharges of the flood hydrograph, both bedforms could be present in the project reach during a flood event. The scour component is limited to a maximum of $\frac{1}{2}$ the dune height or $\frac{1}{2}$ the flow depth.

Low-flow thalweg scour, Z_{lift} , occurs if a small wash forms to convey minor flows within the main channel of a wash cross-section. The intent of the low-flow thalweg scour component is to address a feature that sometimes forms within large washes (with bottom widths greater than the natural bank full width) with a high width to depth ratio and with mobile bed sediments. Based on field observation, a low-flow depression already exists in the wash bed, and computed scour depth was applied below this elevation. Therefore, a value of zero was used for this component.

Local scour, Z_{local} , results from an obstruction and abrupt change in the direction of flow. It occurs at bridge piers, abutments, embankments, and other structures obstructing flow. There are no local scour elements in this reach. Therefore, the value for this item was set to zero.

Scour calculations are provided in **Appendix H**, and the total scour result is discussed in **Section 5.4**.

5. PROPOSED DRAINAGE CONDITIONS

The Preliminary Grading and Drainage Plans are provided within **Appendix A**.

5.1 ON-SITE

The Gold Dust Apartments project includes a new building and associated site improvements, Existing storm drains that lead to the wash will be removed. A combination of storm drains, roof drains, and surface flow will capture the runoff and outfall into underground concrete tanks. There will also be 1 drywell implemented to meet the requirement of bleed off in 36 hours.

A total of five (5) StormCapture concrete tanks will be used. These tanks are sized at 7x15x14. The volume required from these retention tanks were determined using the first flush precipitation depth of 0.5 inches. Any water in excess of the first flush will flow into the wash via pipes from the retention tank or surface runoff. The east drainage area was calculated to be 91,008 square feet and produces approximately 14.84 cfs and is planned to flow into the east storm drain. The west drainage area was calculated to be 65,116 square feet and is planned to drain into the retention tanks from a drain system internal to the garage. The

total site drainage area is in the table below and summarizes the drainage calculations for the total site. Within the retention tanks, a system with a single storm drain is planned to allow extra water above the first flush (0.5-inch depth) to flow into the wash. The first flush outflows will be treated with a drywell within the StormCapture concrete tanks. The water will be discharged back into the ground. See **Appendix I** for storm drain profiles based on the 100-year storm, the overflow pipe for bypass beyond first flush has not been modeled, but is sized to match the highest flow in the on-site conveyance.

Refer to **Table 3** for a summary of the drainage calculations.

Table 3 - PROPOSED DRAINAGE VOLUME SUMMARY

| DRAINAGE AREA | DRAINAGE AREA [SF] | VOLUME REQUIRED [CF] | VOLUME PROVIDED [CF] | BLEED OFF TIME [HR] |
|---------------|--------------------|----------------------|----------------------|---------------------|
| A | 156,124 | 6,180 | 7,350.00 | 17.2 |

The proposed site has a volume required less than that of the existing site due to the increase of desert landscaping areas. See **Appendix D** for volume calculations.

5.2 MAINTENANCE PLAN

Regular maintenance is recommended annually. Deposited silt and sediments may need to be removed from the retention tanks annually. It is recommended that the removal of sediment is to be done when levels fill up to 10 percent of the effective settling capacity.

5.3 FINISHED FLOORS

The site drainage design will provide protection of the proposed building on the site from the 100-year storm event. The lowest habitable finish floor is 1344.50, which is approximately 3.5 feet above the ultimate overland outfall of the site, and 4.44 feet above the 100-year water surface elevation (1340.06) at the north end of the building on the high end of the site. The wash will be armored to protect from lateral migration, and there is no indication of water reaching the underground parking, the walls will be waterproofed, but not floodproofed based on their distance from the wash.

5.4 OFF-SITE

Hydraulic modeling of the unnamed channel on the western site boundary supports that the 100-year design storm event is contained within the existing channel banks. Water surface elevations at selected locations are provided on the Grading and Drainage Plan.

An assessment of the erodibility of the wash and potential for lateral migration supports that a 150-foot length of the existing channel, beginning at the downstream end of an existing concrete access ramp and extending south, is potentially erosive and has lateral migration potential during the peak of the 100-year storm event.

To eliminate the potential for lateral migration, riprap erosion protection has been designed for the the at-risk portion of the east bank. The riprap lining follows the existing bank geometry with some smoothing of existing irregularities in the bank slope. The proposed condition maximum velocity is 5 feet per second, and the calculated total scour depth of the bed, Z_t , is 2.3'. A riprap D_{50} value of 4 inches and an apron depth of 12 inches have been provided for bank protection. A riprap sizing calculation is provided in **Appendix H**. The bank protection extends below grade (a toe-down) to below the calculated total scour depth. The total scour depth was applied to the lowest, adjacent bed elevation. Because the proposed bank toe elevation is slightly above the existing bed elevation at some locations, a constant toe-down depth below the toe was calculated to provide a value deep enough for all locations. This resulted in the toe-down dimension of 3.2'



shown on the Grading and Drainage Plan. The remainder of the channel was found to be non-erodible, and, therefore, no erosion setback or lining is necessary. No other modifications to the existing channel are expected.

6. CONCLUSIONS

The construction of the Gold Dust Apartments facility drainage is designed to retain the first flush runoff as part of the proposed site improvements. Flows are routed via roof drains, surface drainage and storm drain pipes to underground retention tanks and the existing wash. The drainage features associated with this project will have adequate capacity to retain the first flush and to convey the 100-year storm. The ultimate outfall is located on the southwest corner of the site over the box culvert at an elevation of 1340.56 or at the bottom of the culvert in smaller storms at 1335.16. The unnamed wash at the western site boundary has the capacity to convey the 100-year peak discharge without overtopping its banks and riprap bank protection of erodible areas will eliminate the potential for lateral migration into the developed areas of the site.

7. REFERENCES

City of Scottsdale, *Design Standards and Policies Manual*, 2018.

Flood Control District of Maricopa County, *Drainage Design Manual for Maricopa County, Arizona, Volume I, Hydrology*, 2018.

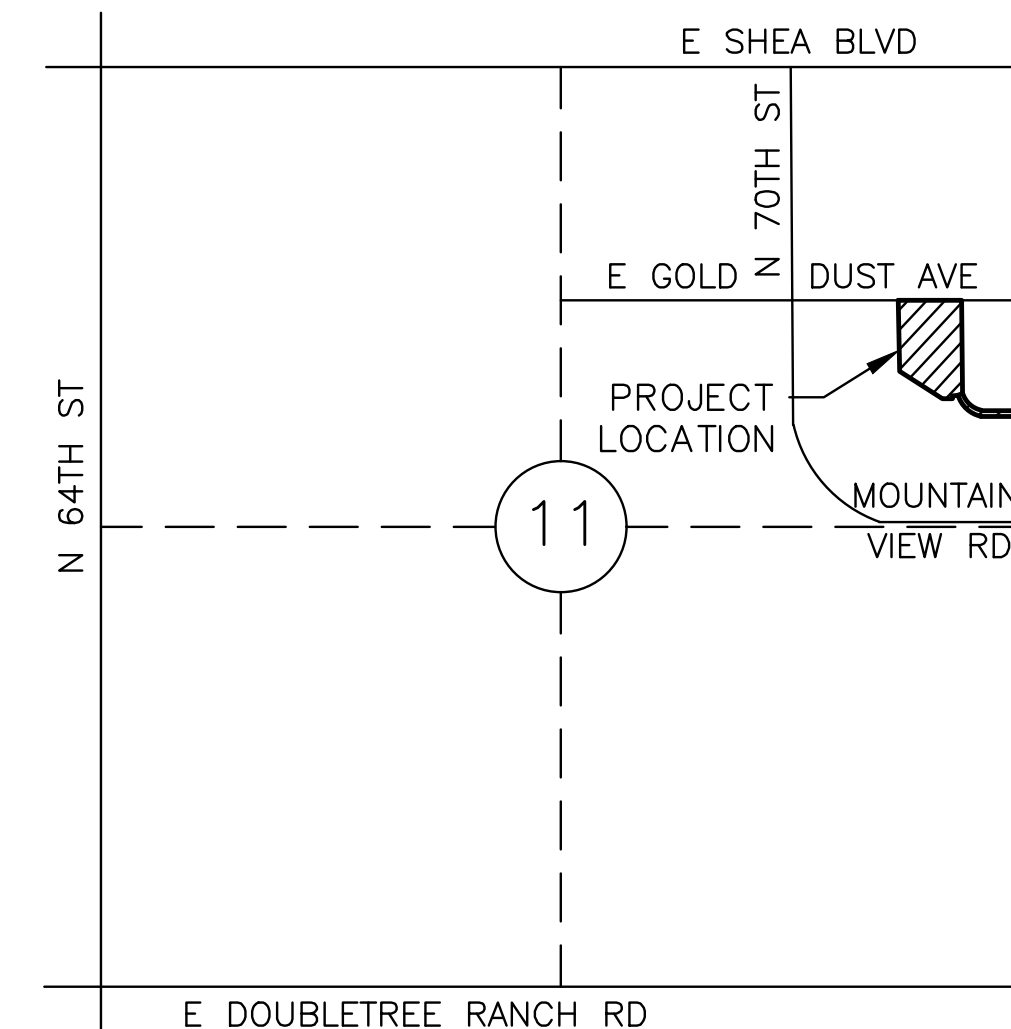
Arizona Department of Water Resources, *State Standard Attachment SSA 5-96 for Watercourse System Sediment Balance*, 1996



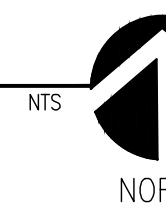
Appendix A – PRELIMINARY GRADING AND DRAINAGE PLAN



500 Washington Avenue South, Suite 1080
Minneapolis, MN 55415
p 612.339.5508 | f 612.339.5382
www.esgarch.com



VICINITY MAP
SEC 11 T3N R4E



RETENTION CALCULATIONS

DRAINAGE AREA

VOLUME REQUIRED:
 $V = C * A * (P / 12)$
 $V = (0.95) * (156,124 \text{ SF}) * (0.5 \text{ IN} / 12)$
 $V = 6,180 \text{ CF}$

VOLUME PROVIDED:
FIVE 14 FT TALL STORM CAPTURE RETENTION TANKS @ VOLUME PER TANK CF/TANK = 1,470 CF

TOTAL VOLUME (5) TANKS = 7,350 CF

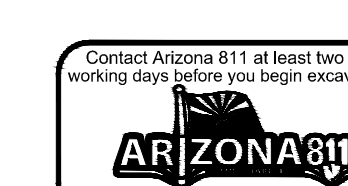
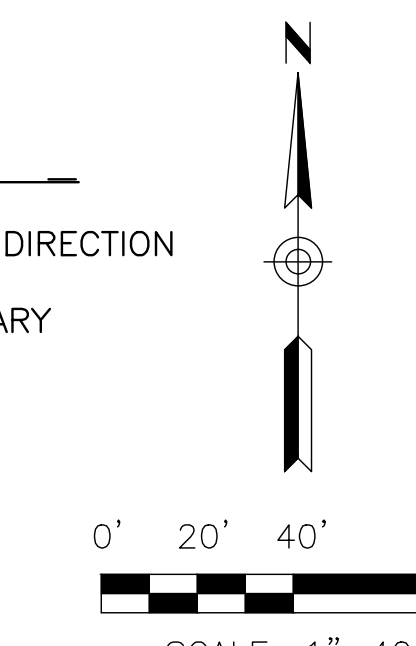
1 DRYWELLS TO DRAIN IN 17.2 HRS

NOTE:

1. ALL CURB RAMPS ON THE SUBJECT PARCEL, AND WITHIN THE PUBLIC ROW AND EASEMENTS, TO BE INVESTIGATED FOR ADA COMPLIANCE AND UPDATED ACCORDINGLY.

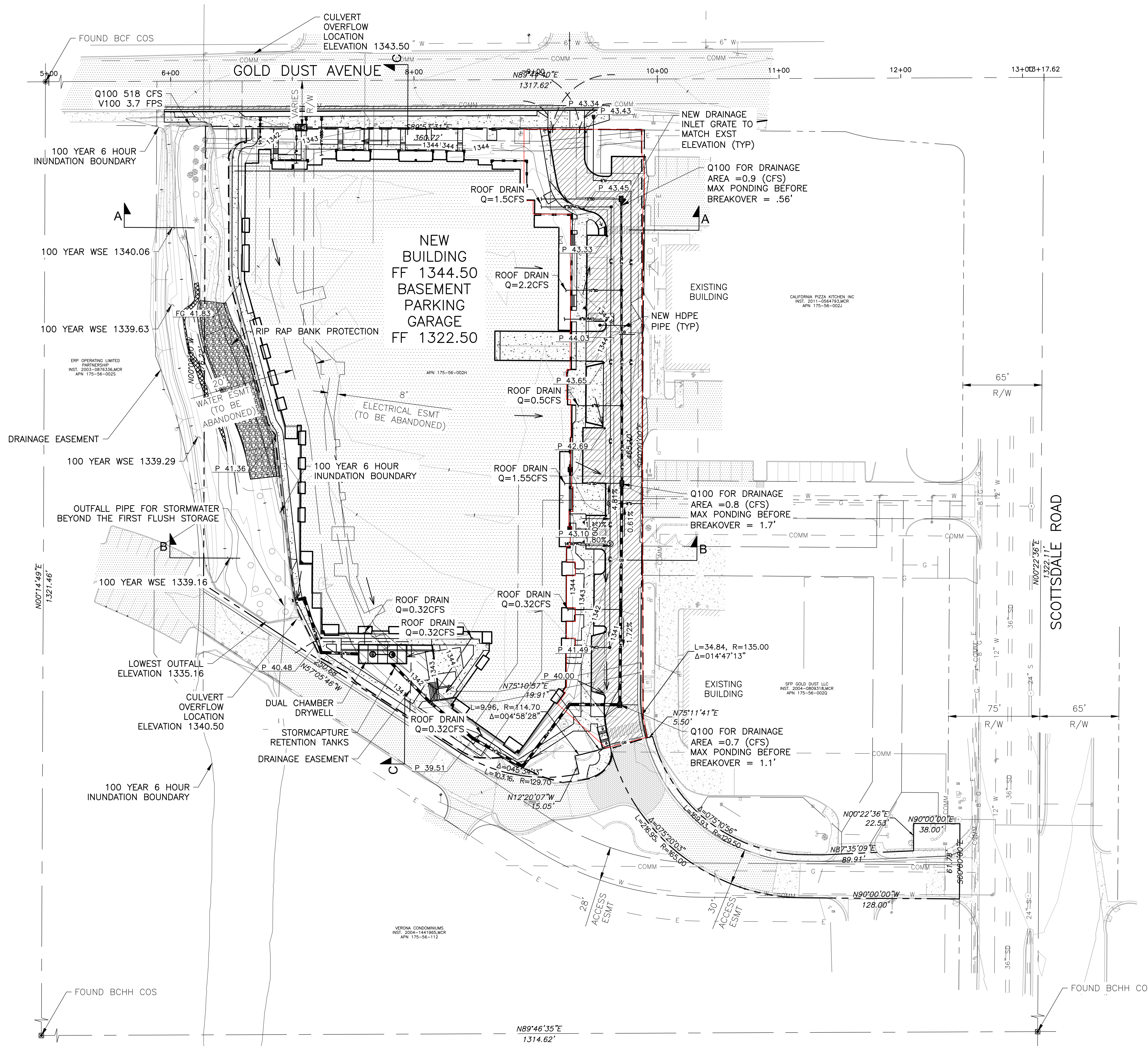
LEGEND

- ← PROPOSED FLOW DIRECTION
- - - DRAINAGE BOUNDARY

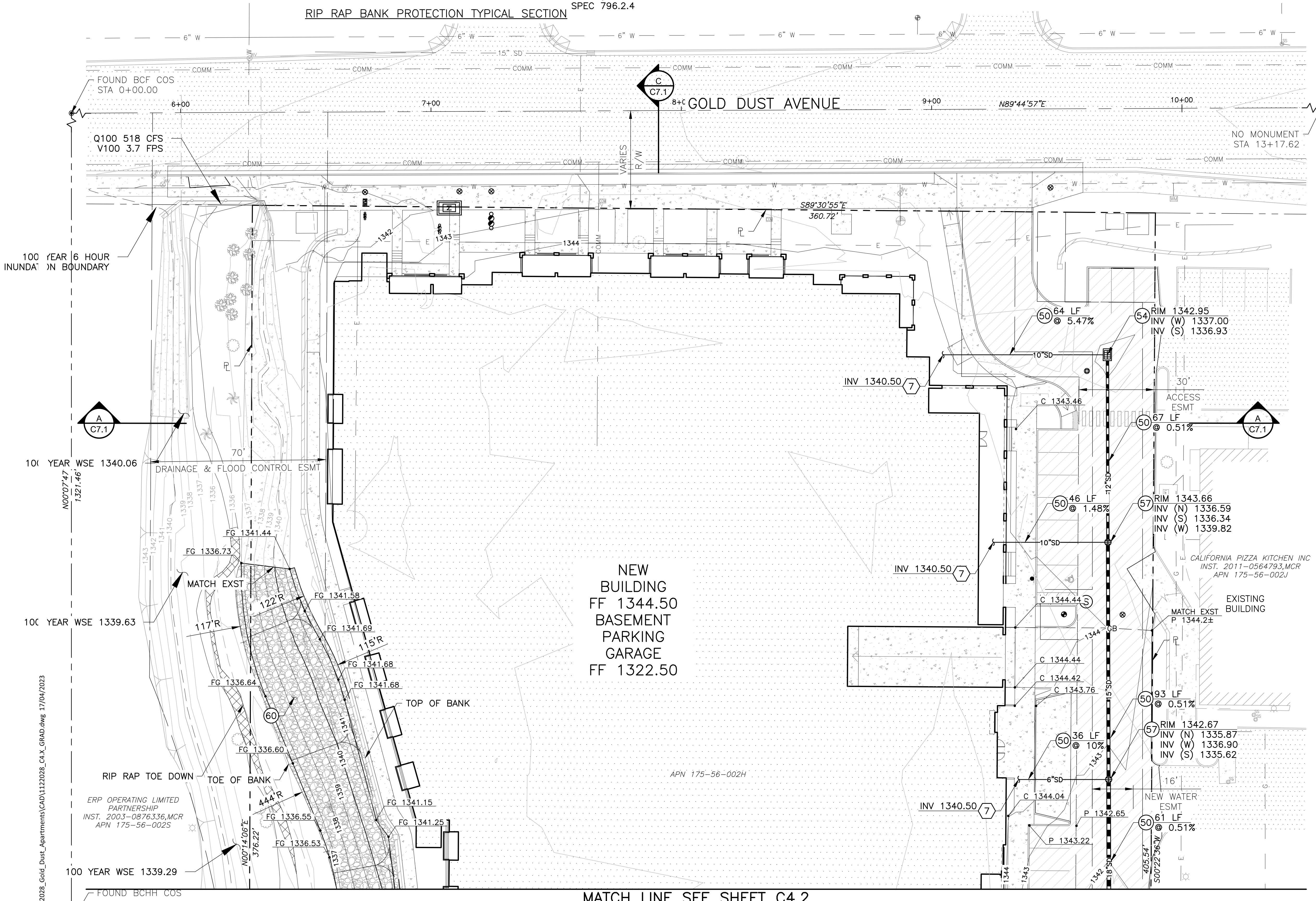
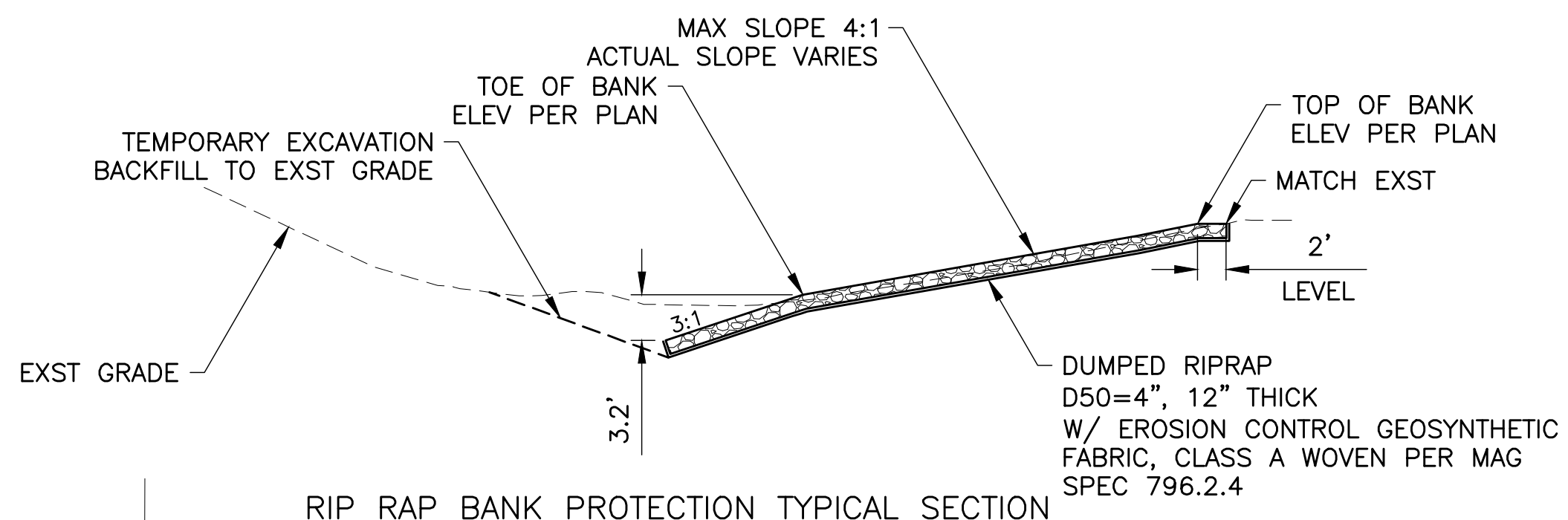


PRELIMINARY GRADING & DRAINAGE PLAN

C1.1



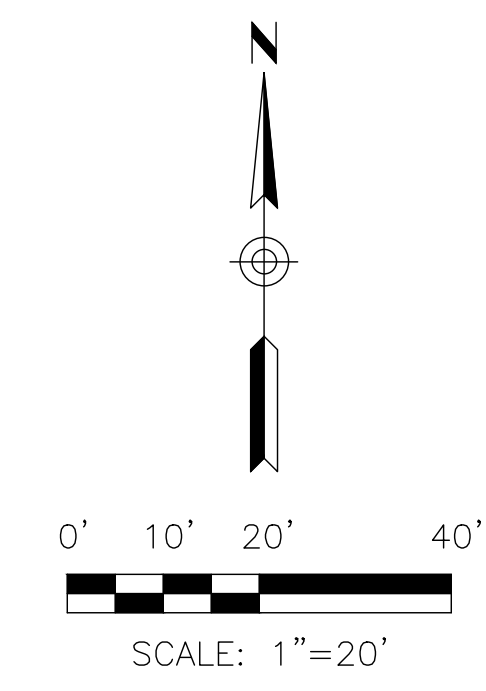
G:\2021\112028_Gold_Dust_Apartments\CAD\112028_PRELIM SITE.dwg 03/02/2023



- CONSTRUCTION NOTES**
- 50 STORM DRAIN, HDPE (WATER TIGHT) SIZE PER PLAN ADS N-12 WT OR APPROVED EQUAL
 - 54 DRAIN BASIN W/2'X3' MAG GRATE (H-20 TRAFFIC), DET 4, SHEET C6.1 ADS NYLOPLAST OR APPROVED EQUAL
 - 57 DRAIN BASIN W/GRATED LID (H-20 TRAFFIC) DET 4, SHEET C6.1 ADS NYLOPLAST OR APPROVED EQUAL
 - 60 RIP RAP BANK PROTECTION PER TYPICAL SECTION THIS SHEET

- REFERENCE NOTES**
- 7 FOR CONTINUATION REFER TO PLUMBING PLANS

- NOTES:**
1. ONLY STORM DRAIN UTILITIES SHOWN FOR CLARITY.
 2. ADD 1000' TO ALL SPOT GRADES & INVERT ELEVATIONS.
 3. ALL TOP OF CURBS ARE 6" ABOVE PAVEMENT ELEVATION UNLESS OTHERWISE NOTED.
 4. ALL UTILITY SURFACE FEATURES SHALL BE ADJUSTED TO FINISH GRADE INCLUDING BUT NOT LIMITED TO UTILITY BOXES, VALVES, METER BOXES, VAULTS, MANHOLES, BACKFLOWS, GRATES, ETC.
 5. ALL NEW SIDEWALK, PAVING AND OTHER HARDSCAPE FEATURES SHALL MATCH IN WITH EXISTING ADJACENT GRADES.
 6. ALL SIDEWALK & ADA ROUTES SHALL BE CONSTRUCTED WITH 5% MAX SLOPE IN THE DIRECTION OF TRAVEL AND 2% MAX CROSS SLOPE.



Gold Dust Ave & Scottsdale Rd
Scottsdale, AZ

HIGH STREET
RESIDENTIAL

DIBBLE

esc
ARCHITECTURE & DESIGN

500 Washington Avenue South, Suite 1080
Minneapolis, MN 55415
p 612.339.5508 | f 612.339.5382
www.esgarch.com

DRB RE-SUBMITTAL 04/17/2023

ORIGINAL ISSUE:

| REVISIONS No. | Description | Date |
|---------------|-------------|------|
| | | |

PROJECT NUMBER: 221564
 DRAWN BY: KR
 CHECKED BY: SM

KEY PLAN

Gold Dust Ave & Scottsdale Rd

GRADING & DRAINAGE PLAN

C4.1

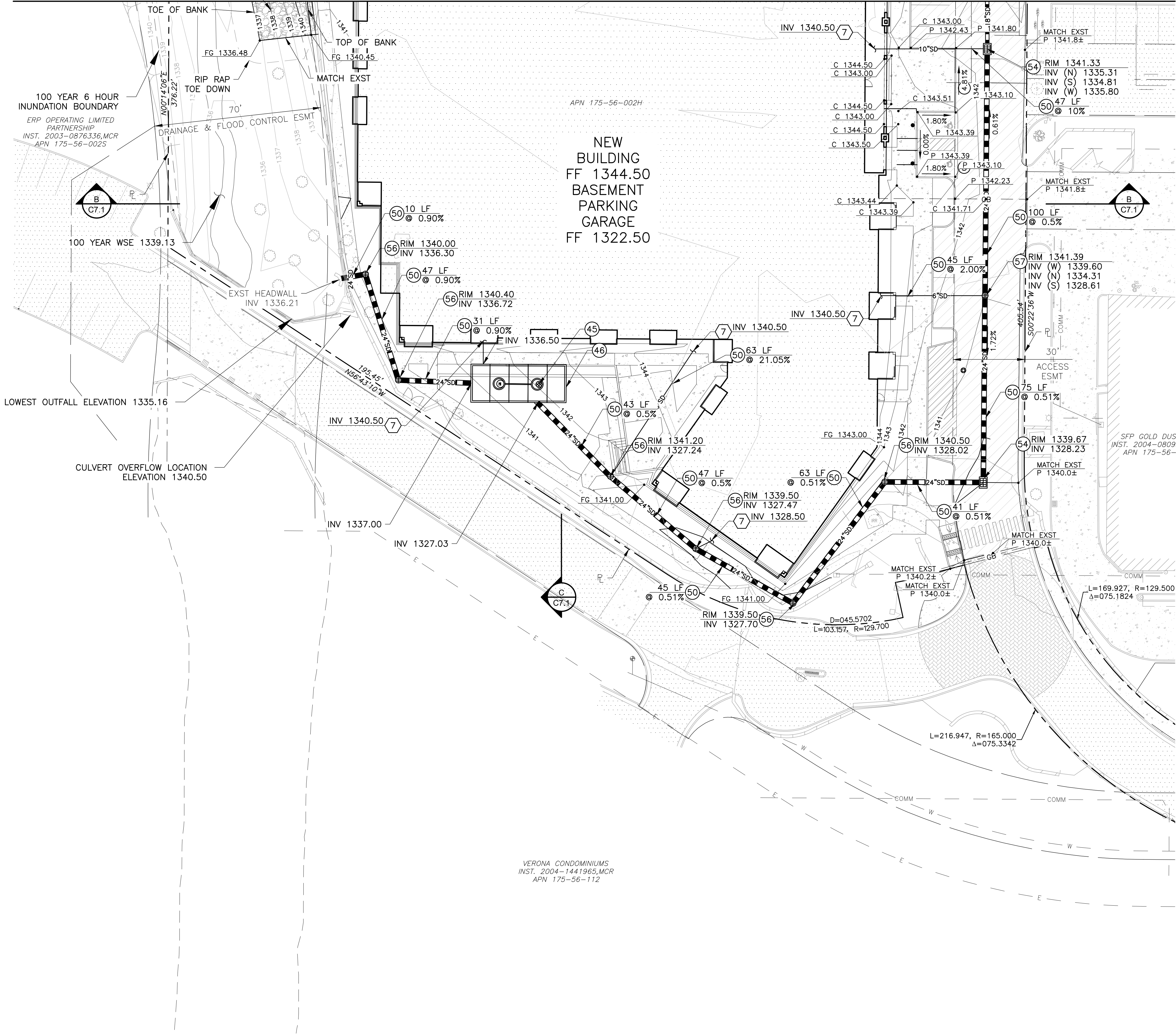
G:\2022\1122028_Gold_Dust_Apartments\CAD\1122028_C4_X_GRAD.dwg 17/04/2023

ERP OPERATING LIMITED PARTNERSHIP
 INST. 2003-0876336,MCR
 APN 175-56-002S

MATCH LINE SEE SHEET C4.2



MATCH LINE SEE SHEET C4.1



CONSTRUCTION NOTES

- 45 DUAL CHAMBER DRYWELL MAXWELL PLUS OR APPROVED EQUAL DET 2, SHEET C6.2
- 46 STORMCAPTURE CONCRETE TANKS DET 1, SHEET C6.2
- 50 STORM DRAIN, HDPE (WATER TIGHT) SIZE PER PLAN ADS N-12 WT OR APPROVED EQUAL
- 54 DRAIN BASIN W/2'X3' MAG GRATE (H-20 TRAFFIC), DET 4, SHEET C6.1 ADS NYLOPLAST OR APPROVED EQUAL
- 56 DRAIN BASIN W/GRATED LID (PEDESTRIAN) DET 5, SHEET C6.1 ADS NYLOPLAST OR APPROVED EQUAL
- 57 DRAIN BASIN W/GRATED LID (H-20 TRAFFIC) DET 4, SHEET C6.1 ADS NYLOPLAST OR APPROVED EQUAL
- 60 RIP RAP BANK PROTECTION PER TYPICAL SECTION THIS SHEET

Gold Dust Ave & Scottsdale Rd
Scottsdale, AZ

HIGH STREET
RESIDENTIAL

DIBBLE

escg
ARCHITECTURE & DESIGN

500 Washington Avenue South, Suite 1080
Minneapolis, MN 55415
p 612.339.5508 | f 612.339.5382
www.esgarch.com

DRB
RE-SUBMITTAL
04/17/2023

ORIGINAL ISSUE:
REVISIONS

| No. | Description | Date |
|-----|-------------|------|
| | | |

- NOTES:
- ONLY STORM DRAIN UTILITIES SHOWN FOR CLARITY.
 - ADD 1000' TO ALL SPOT GRADES & INVERT ELEVATIONS.
 - ALL TOP OF CURBS ARE 6" ABOVE PAVEMENT ELEVATION UNLESS OTHERWISE NOTED.
 - ALL UTILITY SURFACE FEATURES SHALL BE ADJUSTED TO FINISH GRADE INCLUDING BUT NOT LIMITED TO UTILITY BOXES, VALVES, METER BOXES, VAULTS, MANHOLES, BACKFLOWS, GRATES, ETC.
 - ALL NEW SIDEWALK, PAVING AND OTHER HARDSCAPE FEATURES SHALL MATCH IN WITH EXISTING ADJACENT GRADES.
 - ALL SIDEWALK & ADA ROUTES SHALL BE CONSTRUCTED WITH 5% MAX SLOPE IN THE DIRECTION OF TRAVEL AND 2% MAX CROSS SLOPE.

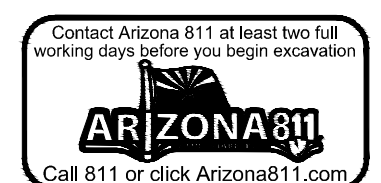
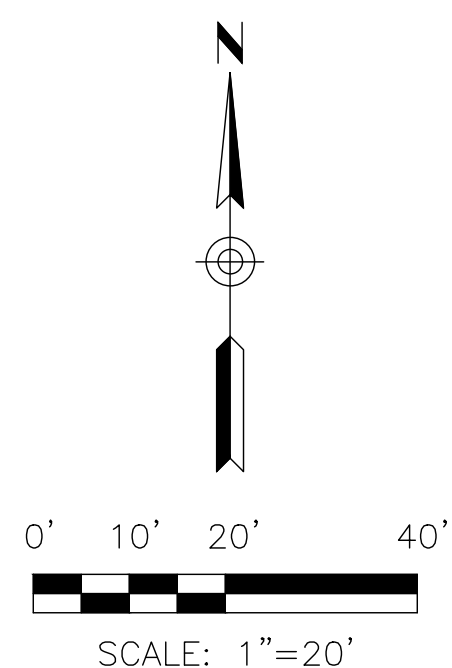
221564
PROJECT NUMBER
KR SM
DRAWN BY CHECKED BY

KEY PLAN

Gold Dust Ave & Scottsdale Rd

GRADING & DRAINAGE PLAN

C4.2



G:\2021\112028_Gold_Dust_Apartments\CA0\112028_C4_X_GRAD.dwg 17/04/2023

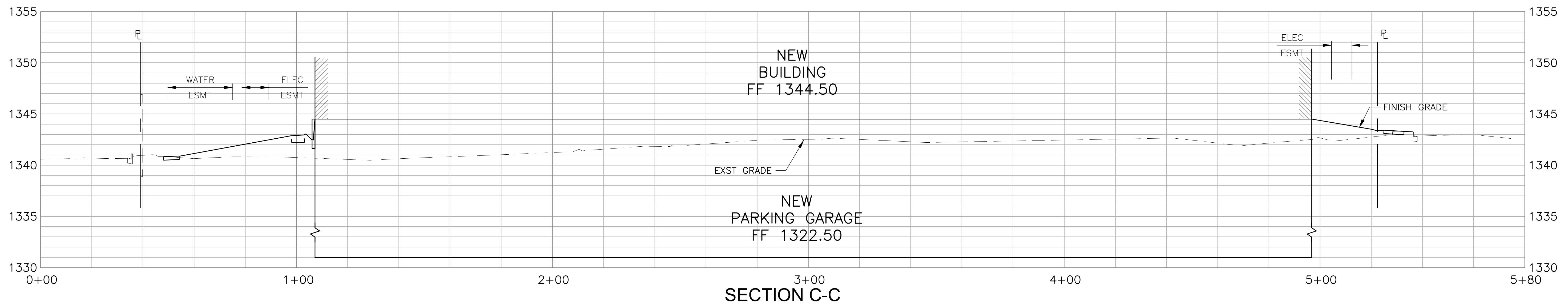
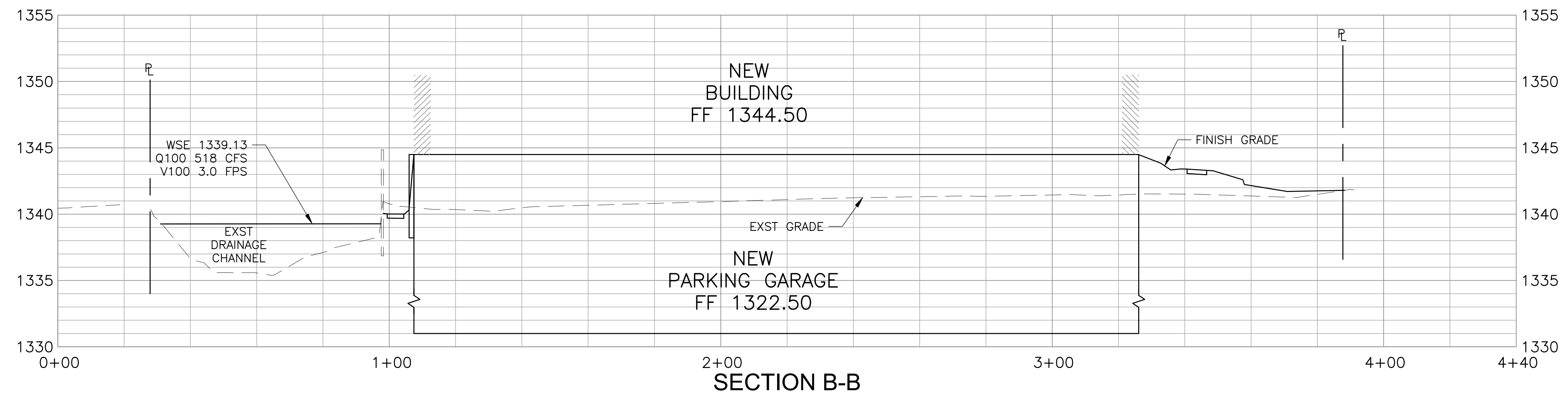
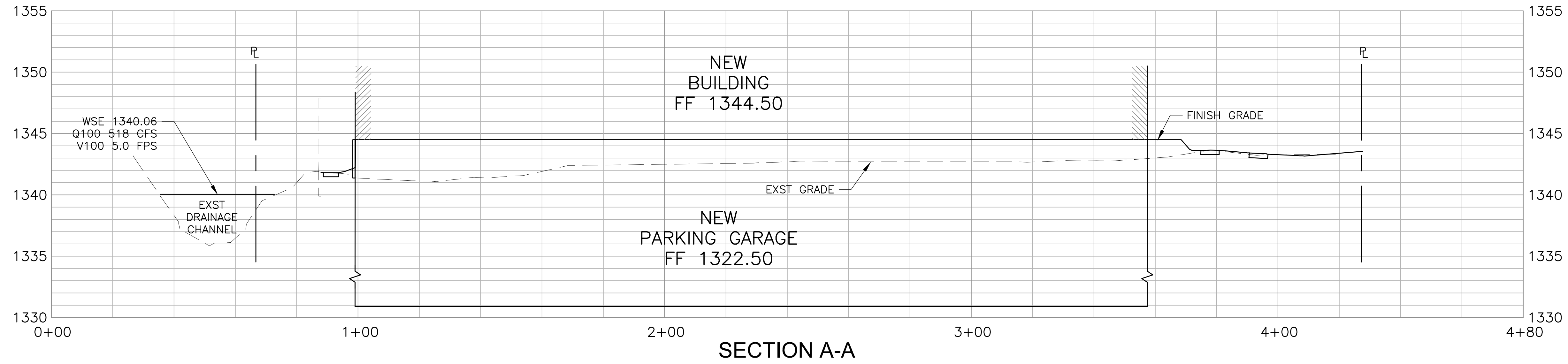
VERONA CONDOMINIUMS
INST. 2004-1441965, MCR
APN 175-56-112

APN 175-56-002H

SFP GOLD DUST LLC
INST. 2004-0809318, MCR
APN 175-56-002Q



500 Washington Avenue South, Suite 1080
Minneapolis, MN 55415
p 612.339.5508 | f 612.339.5382
www.esgarch.com



G:\2021\112028_Gold_Dust_Apartments\CA0\112028_C7_X_XSEC.dwg, 17/04/2023

DRB
RE-SUBMITTAL
04/17/2023

ORIGINAL ISSUE:
REVISIONS

| No. | Description | Date |
|-----|-------------|------|
| | | |

221564
PROJECT NUMBER
KR SM
DRAWN BY CHECKED BY

KEY PLAN

Gold Dust Ave &
Scottsdale Rd

CROSS SECTIONS
C7.1

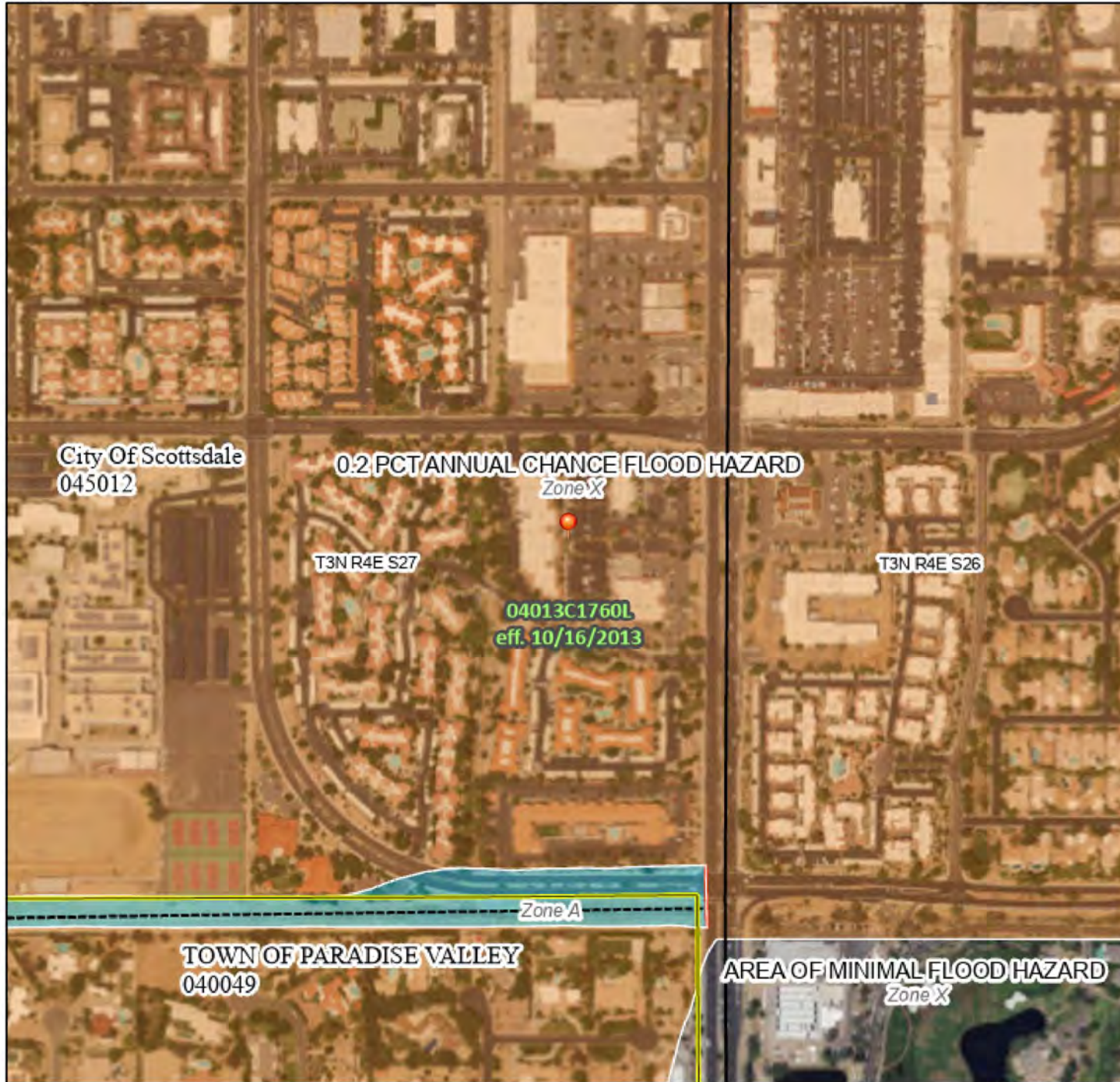


Appendix B – FEMA FIRMETTE MAP

National Flood Hazard Layer FIRMette



111°55'58"W 33°34'54"N



0 250 500 1,000 1,500 2,000 Feet 1:6,000

111°55'20"W 33°34'24"N

Basemap: USGS National Map: Orthoimagery: Data refreshed October, 2020

Legend

SEE FIS REPORT FOR DETAILED LEGEND AND INDEX MAP FOR FIRM PANEL LAYOUT

- | | | |
|------------------------------------|--|---|
| SPECIAL FLOOD HAZARD AREAS | | Without Base Flood Elevation (BFE) Zone A, V, A99 |
| | | With BFE or Depth Zone AE, AO, AH, VE, AR |
| | | Regulatory Floodway |
| OTHER AREAS OF FLOOD HAZARD | | 0.2% Annual Chance Flood Hazard, Areas of 1% annual chance flood with average depth less than one foot or with drainage areas of less than one square mile Zone X |
| | | Future Conditions 1% Annual Chance Flood Hazard Zone X |
| | | Area with Reduced Flood Risk due to Levee. See Notes. Zone X |
| | | Area with Flood Risk due to Levee Zone D |
| OTHER AREAS | | NO SCREEN Area of Minimal Flood Hazard Zone X |
| | | Effective LOMRs |
| | | Area of Undetermined Flood Hazard Zone D |
| GENERAL STRUCTURES | | Channel, Culvert, or Storm Sewer |
| | | Levee, Dike, or Floodwall |
| OTHER FEATURES | | 20.2 Cross Sections with 1% Annual Chance Water Surface Elevation |
| | | 17.5 Cross Sections with 1% Annual Chance Water Surface Elevation |
| | | Coastal Transect |
| | | Base Flood Elevation Line (BFE) |
| | | Limit of Study |
| | | Jurisdiction Boundary |
| | | Coastal Transect Baseline |
| | | Profile Baseline |
| | | Hydrographic Feature |
| MAP PANELS | | Digital Data Available |
| | | No Digital Data Available |
| | | Unmapped |
| | | The pin displayed on the map is an approximate point selected by the user and does not represent an authoritative property location. |



This map complies with FEMA's standards for the use of digital flood maps if it is not void as described below. The basemap shown complies with FEMA's basemap accuracy standards

The flood hazard information is derived directly from the authoritative NFHL web services provided by FEMA. This map was exported on 3/17/2022 at 1:15 PM and does not reflect changes or amendments subsequent to this date and time. The NFHL and effective information may change or become superseded by new data over time.

This map image is void if the one or more of the following map elements do not appear: basemap imagery, flood zone labels, legend, scale bar, map creation date, community identifiers, FIRM panel number, and FIRM effective date. Map images for unmapped and unmodernized areas cannot be used for regulatory purposes.

NOTES TO USERS

This map is for use in administering the National Flood Insurance Program. It does not necessarily identify all areas subject to flooding, particularly from local drainage situations of small size. The community map repository should be consulted for available additional or additional flood hazard information.

To obtain more detailed information in areas where **Base Flood Elevations (BFEs)** and/or **Floodways** have been determined, users are encouraged to consult the Flood Profiles and Floodway Data and/or Summary of Significant Elevation Data contained within the Flood Insurance Study (FIS) report that accompanies this FIRF. Users should be aware that BFEs shown on the FIRF represent ground water flood elevations. These BFEs are intended for flood insurance rating purposes only and should not be used as the sole source of flood elevation information. Accordingly, flood elevation data presented in the FIS report should be utilized in conjunction with the FIRF for purposes of construction and/or floodway management.

Coastal Base Flood Elevations shown on this map apply only to westward of 110 North American Vertical Datum of 1988 (NAVD 88). Users of this FIRF should be aware that coastal flood elevations are also provided in the Summary of Significant Elevation Data in the Flood Insurance Study report for the jurisdiction. Elevations shown in the Summary of Significant Elevation Data should be used for construction and/or floodway management purposes when they are higher than the elevations shown on this FIRF.

Routeways of the **Floodways** were computed at cross sections and interpolated between cross sections. The floodways were based on hydraulic considerations with regard to requirements of the National Flood Insurance Program. Floodway widths and other pertinent floodway data are provided in the Flood Insurance Study report for the jurisdiction.

Certain areas not in Special Flood Hazard Areas may be protected by **flood control structures**. Refer to Section 2.4 Flood Protection Measures of the Flood Insurance Study report for information on flood control structures for the jurisdiction.

The **projection** used in the preparation of this map was Arizona State Plane Central zone (SPRZONE) 2005. The **horizontal datum** was NAD 83 (NAD83). GRS1980 spheroid differences in datum (vertical projection) or State Plane zones used in the production of FIRF's for adjacent jurisdictions may result in small positional differences in map features across jurisdiction boundaries. These differences do not affect the accuracy of this FIRF.

Flood elevations on this map are referenced to the North American Vertical Datum of 1988 (NAVD 88). Mean flood elevations must be compared to accurate and geoid elevations referenced to the same vertical datum. Map users wishing to obtain flood elevations referenced to the National Geoid Vertical Datum of 1928 (NGVD 28) may use the following Maricopa County website application: <http://www.flood.maricopa.gov/floodmap/index.jsp?app=spcmapapplication/index.htm>

The web tool allows users to obtain point-specific datum conversion values by entering an area hovering over a VERTCON number on the layers menu on the left side of the screen. The VERTCON grid referenced in the web application was used to convert existing flood elevations from NGVD 29 to NAVD 88.

To obtain current elevation, direction, and/or location information for National Geographic Survey bench marks shown on the map, please contact the Information Services Branch of the National Geodetic Survey at (301) 713-3242, or visit its website at <http://www.ngs.noaa.gov>. To obtain information about Geodetic Description and Control Survey bench marks controlled by the Maricopa County Department of Transportation please visit the Flood Control District of Maricopa County website at: <http://www.fcd.maricopa.gov/Map/geomaps/geomapsapplication/index.htm>

Base map information shown on the FIRF was derived from digital elevation and imagery data provided in digital format by the Maricopa County Department of Public Works, Flood Control District. The imagery is dated October 2008 or November 2009. Additional National Agriculture Imagery Program (NAIP) imagery was provided by the Arizona State Land Department (ASLD) and is dated 2007. The coordinate system used for the production of the digital FIRF is State Plane Arizona Central (NAD83) MARS, international feet.

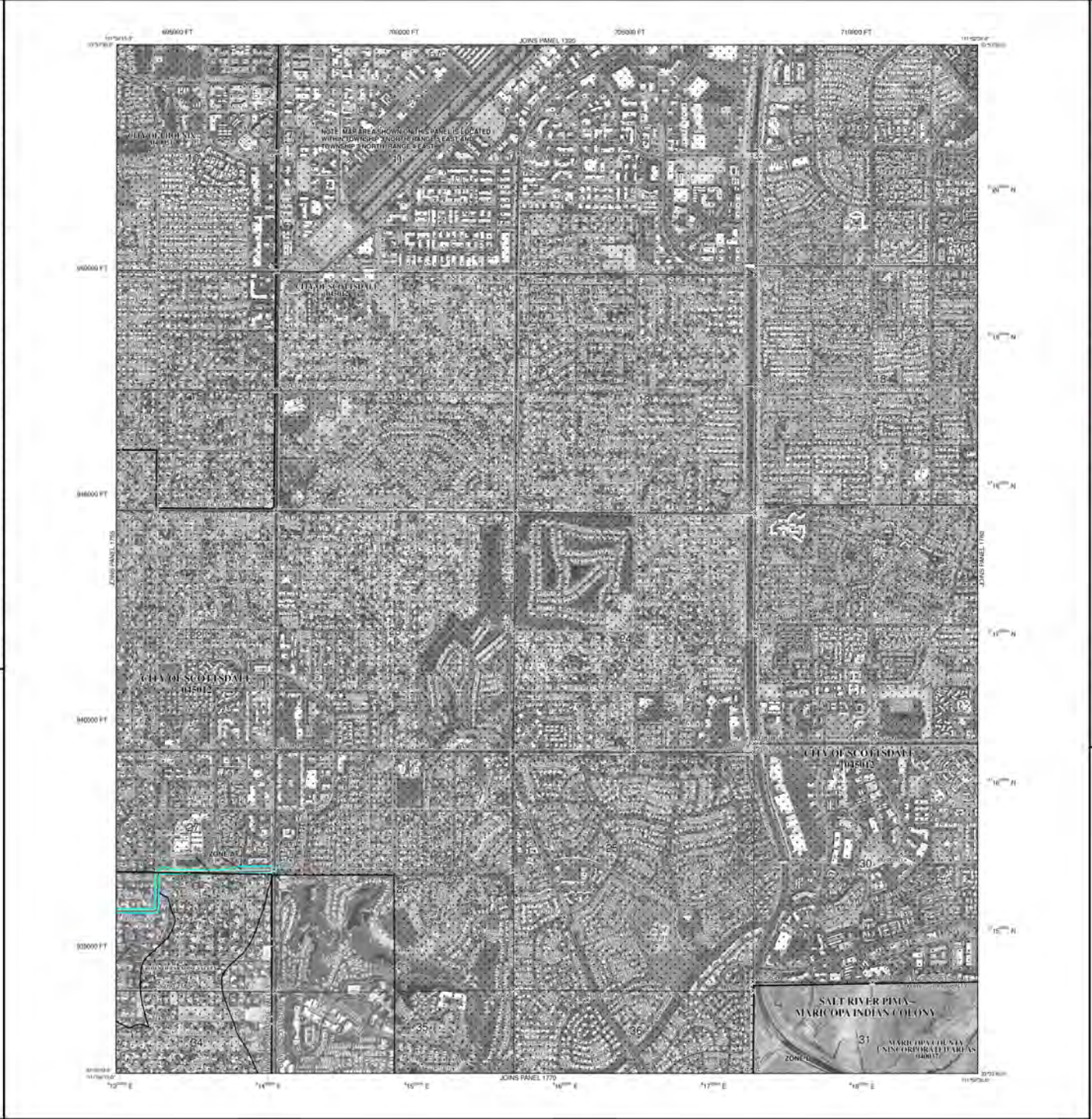
The **profile base line** depicted on the map represents the hydraulic modeling assuming that reach flood profiles in the FIS report. As a result of improved geographic data, the profile base line, or some cases, may deviate significantly from the channel centerline or appear outside the SFHA.

Corporate limits shown on this map are based on the best data available at the time of publication. Because changes due to annexations or de-annexations may have occurred after the map was published, map users should contact appropriate community officials to verify current corporate limit locations.

Please refer to the separately printed **Map Index** for an overview map of the county showing the layout of map panels, community map repository addresses, and a listing of Communities with National Flood Insurance Program data for each community, as well as a listing of the panels on which each community is located.

For information on available products associated with this FIRF, visit the **FEMA Map Service Center (MSC)** website at <http://msc.fema.gov>. Available products may include previously issued Letters of Map Change, a Flood Insurance Study Report, or digital versions of this map. Many of these products will be printed or delivered directly from the MSC website.

If you have **questions about this map**, links to order products, or the National Flood Insurance Program in general, please call the **FEMA Map Information Exchange (MIEX)** at 1-877-FEMA-MAP (1-877-366-6277) or visit the FEMA website at <http://www.fema.gov>.



LEGEND

SPECIAL FLOOD HAZARD AREAS (SFHA) SUBJECT TO DANGEROUS BY THE ANNUAL CHANCE FLOOD

The 1% annual chance flood (100-year flood) was shown on the base flood, in the flood zone, as a 2% annual chance flood, being required to maintain in any area over the 1% annual chance flood area in the area subject to flooding by the 1% annual chance flood. Areas of Special Flood Hazard (SFHA) Zones A, AE, AH, AO, A1, A2, A3, A4, A5, V, and VE. The base flood elevation is the water surface elevation of the 1% annual chance flood.

- ZFONE A: No Base Flood Elevation determined.
- ZFONE AE: Base Flood Elevation determined.
- ZFONE AH: Flood depths of 1 to 3 feet (usually areas of parking) (see Flood Elevation Determination).
- ZFONE AO: Flood depths of 1 to 3 feet (usually areas of flow on existing roads) (see Flood Elevation Determination).
- ZFONE A1: Special Flood Hazard Area formerly protected from the 1% annual chance flood by a flood control system that was abandoned (see Flood Elevation Determination). Zone A1 indicates that the former flood control system is no longer in operation protection from the 1% annual chance flood.
- ZFONE A2: Areas to be protected from 1% annual chance flood by a flood control system (see Flood Elevation Determination).
- ZFONE V: Coastal flood zone with velocity hazard (wave action) (see Flood Elevation Determination).
- ZFONE VE: Coastal flood zone with velocity hazard (wave action) (see Flood Elevation Determination).

FLOODWAY AREAS IN ZONE AE

The floodway is the channel of a stream, plus any adjacent floodplain areas that must be kept free of encroachments so that the 1% annual chance flood can be carried without substantial increases in flood heights.

OTHER FLOOD AREAS

- ZFONE B: Areas of 0.2% annual chance flood (500-year flood) and 1% annual chance flood with a return period of less than 1 year or with elevations above base flood elevation and areas indicated by a return from 1% annual chance flood.

OTHER AREAS

- ZFONE C: Areas determined to be outside the 0.2% annual chance floodway.
- ZFONE D: Areas in which flood hazards are uncontrolled, but possible.

COASTAL BARRIER RESOURCES SYSTEM (CBRS) AREAS

- CBRS: Other CBRS boundaries.
- CBRS: Other CBRS boundaries.

OTHER PROTECTED AREAS (OPA)

- OPA: Other OPA boundaries.
- OPA: Other OPA boundaries.

MAP RESPONSIBILITIES

1:50,000

MAP SCALE 1" = 1000'

NATIONAL FLOOD INSURANCE PROGRAM

FIRM FLOOD INSURANCE RATE MAP

MARICOPA COUNTY, ARIZONA AND INCORPORATED AREAS

PANEL 1760 OF 4425

(SEE MAP INDEX FOR FIRM PANEL LAYOUT)

COMMUNITY

| COMMUNITY | UNIFORM FIRM NUMBER | UNIFORM FIRM NUMBER | UNIFORM FIRM NUMBER |
|-----------------|---------------------|---------------------|---------------------|
| MARICOPA COUNTY | 06001 | 1760 | 1 |
| SCOTTSDALE | 06002 | 1761 | 1 |
| PHOENIX | 06003 | 1762 | 1 |
| CHANDLER | 06004 | 1763 | 1 |
| GLendale | 06005 | 1764 | 1 |
| BUICKLAND | 06006 | 1765 | 1 |

PANEL 1760 OF 4425

COMMUNITY

MARICOPA COUNTY

SCOTTSDALE

PHOENIX

CHANDLER

GLendale

BUICKLAND

MAP NUMBER 04013C1760L

MAP REVISED OCTOBER 16, 2013

Federal Emergency Management Agency



Appendix C – NOAA ATLAS PRECIPITATION DATA



POINT PRECIPITATION FREQUENCY ESTIMATES

Sanja Perica, Sarah Dietz, Sarah Heim, Lillian Hiner, Kazungu Maitaria, Deborah Martin, Sandra Pavlovic, Ishani Roy, Carl Trypaluk, Dale Unruh, Fenglin Yan, Michael Yekta, Tan Zhao, Geoffrey Bonnin, Daniel Brewer, Li-Chuan Chen, Tye Parzybok, John Yarchoan

NOAA, National Weather Service, Silver Spring, Maryland

[PF_tabular](#) | [PF_graphical](#) | [Maps_&_aerials](#)

DEPTH

PF tabular

| PDS-based point precipitation frequency estimates with 90% confidence intervals (in inches)¹ | | | | | | | | | | |
|--|--|------------------------|------------------------|------------------------|------------------------|------------------------|----------------------------|------------------------|------------------------|-----------------------|
| Duration | Average recurrence interval (years) | | | | | | | | | |
| | 1 | 2 | 5 | 10 | 25 | 50 | 100 | 200 | 500 | 1000 |
| 5-min | 0.186 (0.155-0.227) | 0.243 (0.203-0.297) | 0.328 (0.272-0.400) | 0.394 (0.325-0.479) | 0.483 (0.392-0.585) | 0.551 (0.443-0.664) | 0.623 (0.491-0.748) | 0.694 (0.537-0.832) | 0.790 (0.596-0.949) | 0.863 (0.638-1.04) |
| 10-min | 0.283 (0.235-0.346) | 0.369 (0.309-0.452) | 0.499 (0.414-0.609) | 0.600 (0.495-0.729) | 0.736 (0.597-0.891) | 0.840 (0.674-1.01) | 0.948 (0.747-1.14) | 1.06 (0.818-1.27) | 1.20 (0.908-1.44) | 1.31 (0.972-1.58) |
| 15-min | 0.351 (0.292-0.429) | 0.458 (0.383-0.560) | 0.619 (0.514-0.755) | 0.743 (0.614-0.904) | 0.912 (0.741-1.11) | 1.04 (0.835-1.25) | 1.18 (0.926-1.41) | 1.31 (1.01-1.57) | 1.49 (1.13-1.79) | 1.63 (1.21-1.96) |
| 30-min | 0.473 (0.393-0.578) | 0.617 (0.516-0.755) | 0.834 (0.692-1.02) | 1.00 (0.827-1.22) | 1.23 (0.997-1.49) | 1.40 (1.13-1.69) | 1.58 (1.25-1.90) | 1.76 (1.37-2.11) | 2.01 (1.52-2.41) | 2.19 (1.62-2.64) |
| 60-min | 0.585 (0.486-0.715) | 0.763 (0.639-0.934) | 1.03 (0.856-1.26) | 1.24 (1.02-1.51) | 1.52 (1.23-1.84) | 1.74 (1.39-2.09) | 1.96 (1.54-2.35) | 2.18 (1.69-2.62) | 2.49 (1.88-2.98) | 2.71 (2.01-3.26) |
| 2-hr | 0.684 (0.577-0.817) | 0.884 (0.749-1.06) | 1.18 (0.992-1.41) | 1.41 (1.17-1.67) | 1.72 (1.42-2.03) | 1.95 (1.59-2.30) | 2.19 (1.75-2.58) | 2.44 (1.92-2.87) | 2.77 (2.13-3.26) | 3.03 (2.27-3.58) |
| 3-hr | 0.762 (0.643-0.930) | 0.977 (0.827-1.20) | 1.28 (1.08-1.56) | 1.52 (1.26-1.84) | 1.85 (1.52-2.23) | 2.12 (1.72-2.53) | 2.39 (1.91-2.86) | 2.68 (2.10-3.20) | 3.08 (2.34-3.68) | 3.40 (2.52-4.07) |
| 6-hr | 0.918 (0.789-1.09) | 1.16 (0.997-1.38) | 1.48 (1.27-1.75) | 1.74 (1.47-2.04) | 2.09 (1.75-2.44) | 2.36 (1.95-2.75) | 2.65 (2.15-3.08) | 2.94 (2.34-3.43) | 3.34 (2.59-3.89) | 3.65 (2.77-4.26) |
| 12-hr | 1.02 (0.878-1.19) | 1.28 (1.11-1.51) | 1.62 (1.39-1.90) | 1.88 (1.61-2.20) | 2.24 (1.90-2.61) | 2.51 (2.10-2.92) | 2.80 (2.30-3.25) | 3.08 (2.51-3.58) | 3.46 (2.75-4.04) | 3.76 (2.93-4.42) |
| 24-hr | 1.19 (1.03-1.39) | 1.51 (1.31-1.77) | 1.95 (1.69-2.29) | 2.30 (1.99-2.69) | 2.78 (2.39-3.25) | 3.16 (2.70-3.69) | 3.56 (3.01-4.16) | 3.97 (3.33-4.64) | 4.54 (3.75-5.30) | 4.99 (4.07-5.84) |
| 2-day | 1.28 (1.11-1.49) | 1.63 (1.42-1.90) | 2.13 (1.85-2.49) | 2.54 (2.19-2.95) | 3.09 (2.65-3.59) | 3.54 (3.01-4.10) | 4.00 (3.38-4.65) | 4.48 (3.76-5.22) | 5.16 (4.26-6.01) | 5.70 (4.65-6.65) |
| 3-day | 1.36 (1.19-1.58) | 1.74 (1.52-2.02) | 2.29 (1.99-2.65) | 2.73 (2.37-3.16) | 3.35 (2.88-3.87) | 3.84 (3.29-4.44) | 4.37 (3.71-5.05) | 4.92 (4.14-5.70) | 5.70 (4.73-6.59) | 6.32 (5.20-7.34) |
| 4-day | 1.45 (1.27-1.67) | 1.85 (1.62-2.14) | 2.45 (2.13-2.82) | 2.92 (2.54-3.37) | 3.60 (3.11-4.15) | 4.15 (3.56-4.78) | 4.74 (4.04-5.45) | 5.36 (4.53-6.18) | 6.23 (5.20-7.18) | 6.95 (5.74-8.03) |
| 7-day | 1.64 (1.42-1.90) | 2.09 (1.82-2.42) | 2.77 (2.40-3.20) | 3.31 (2.86-3.83) | 4.08 (3.51-4.72) | 4.70 (4.02-5.43) | 5.36 (4.55-6.19) | 6.07 (5.10-7.02) | 7.06 (5.86-8.16) | 7.86 (6.46-9.10) |
| 10-day | 1.76 (1.54-2.03) | 2.26 (1.97-2.60) | 2.98 (2.59-3.43) | 3.56 (3.08-4.09) | 4.37 (3.77-5.02) | 5.02 (4.31-5.76) | 5.72 (4.87-6.56) | 6.44 (5.45-7.41) | 7.47 (6.23-8.58) | 8.29 (6.85-9.54) |
| 20-day | 2.17 (1.91-2.50) | 2.80 (2.45-3.21) | 3.70 (3.24-4.24) | 4.38 (3.82-5.01) | 5.30 (4.60-6.05) | 6.00 (5.19-6.85) | 6.71 (5.78-7.69) | 7.44 (6.37-8.53) | 8.42 (7.15-9.68) | 9.18 (7.74-10.6) |
| 30-day | 2.55 (2.22-2.92) | 3.28 (2.87-3.76) | 4.32 (3.77-4.94) | 5.12 (4.46-5.84) | 6.18 (5.36-7.06) | 7.00 (6.05-7.98) | 7.84 (6.74-8.94) | 8.70 (7.44-9.89) | 9.85 (8.36-11.2) | 10.7 (9.04-12.3) |
| 45-day | 2.93 (2.58-3.34) | 3.78 (3.32-4.31) | 4.97 (4.37-5.66) | 5.86 (5.14-6.67) | 7.03 (6.14-8.00) | 7.91 (6.88-9.00) | 8.80 (7.61-10.0) | 9.69 (8.35-11.0) | 10.9 (9.29-12.4) | 11.7 (9.98-13.4) |
| 60-day | 3.22 (2.85-3.66) | 4.16 (3.67-4.72) | 5.47 (4.83-6.20) | 6.43 (5.65-7.28) | 7.67 (6.73-8.68) | 8.59 (7.50-9.72) | 9.51 (8.27-10.8) | 10.4 (9.02-11.8) | 11.6 (9.98-13.2) | 12.5 (10.7-14.2) |

¹ Precipitation frequency (PF) estimates in this table are based on frequency analysis of partial duration series (PDS). Numbers in parenthesis are PF estimates at lower and upper bounds of the 90% confidence interval. The probability that precipitation frequency estimates (for a given duration and average recurrence interval) will be greater than the upper bound (or less than the lower bound) is 5%. Estimates at upper bounds are not checked against probable maximum precipitation (PMP) estimates and may be higher than currently valid PMP values. Please refer to NOAA Atlas 14 document for more information.

[Back to Top](#)

PF graphical



POINT PRECIPITATION FREQUENCY ESTIMATES

Sanja Perica, Sarah Dietz, Sarah Heim, Lillian Hiner, Kazungu Maitaria, Deborah Martin, Sandra Pavlovic, Ishani Roy, Carl Trypaluk, Dale Unruh, Fenglin Yan, Michael Yekta, Tan Zhao, Geoffrey Bonnin, Daniel Brewer, Li-Chuan Chen, Tye Parzybok, John Yarchoan

NOAA, National Weather Service, Silver Spring, Maryland

[PF_tabular](#) | [PF_graphical](#) | [Maps_&_aerials](#)

INTENSITY

PF tabular

| PDS-based point precipitation frequency estimates with 90% confidence intervals (in inches/hour) ¹ | | | | | | | | | | |
|---|-------------------------------------|------------------------|------------------------|------------------------|------------------------|------------------------|------------------------|------------------------|------------------------|------------------------|
| Duration | Average recurrence interval (years) | | | | | | | | | |
| | 1 | 2 | 5 | 10 | 25 | 50 | 100 | 200 | 500 | 1000 |
| 5-min | 2.23 (1.86-2.72) | 2.92 (2.44-3.56) | 3.94 (3.26-4.80) | 4.73 (3.90-5.75) | 5.80 (4.70-7.02) | 6.61 (5.32-7.97) | 7.48 (5.89-8.98) | 8.33 (6.44-9.98) | 9.48 (7.15-11.4) | 10.4 (7.66-12.5) |
| 10-min | 1.70 (1.41-2.08) | 2.21 (1.85-2.71) | 2.99 (2.48-3.65) | 3.60 (2.97-4.37) | 4.42 (3.58-5.35) | 5.04 (4.04-6.07) | 5.69 (4.48-6.83) | 6.34 (4.91-7.60) | 7.22 (5.45-8.66) | 7.88 (5.83-9.47) |
| 15-min | 1.40 (1.17-1.72) | 1.83 (1.53-2.24) | 2.48 (2.06-3.02) | 2.97 (2.46-3.62) | 3.65 (2.96-4.42) | 4.16 (3.34-5.01) | 4.70 (3.70-5.64) | 5.24 (4.06-6.28) | 5.96 (4.50-7.16) | 6.51 (4.82-7.83) |
| 30-min | 0.946 (0.786-1.16) | 1.23 (1.03-1.51) | 1.67 (1.38-2.03) | 2.00 (1.65-2.44) | 2.46 (1.99-2.98) | 2.80 (2.25-3.37) | 3.17 (2.49-3.80) | 3.53 (2.73-4.23) | 4.02 (3.03-4.82) | 4.39 (3.24-5.27) |
| 60-min | 0.585 (0.486-0.715) | 0.763 (0.639-0.934) | 1.03 (0.856-1.26) | 1.24 (1.02-1.51) | 1.52 (1.23-1.84) | 1.74 (1.39-2.09) | 1.96 (1.54-2.35) | 2.18 (1.69-2.62) | 2.49 (1.88-2.98) | 2.71 (2.01-3.26) |
| 2-hr | 0.342 (0.288-0.408) | 0.442 (0.374-0.530) | 0.590 (0.496-0.702) | 0.702 (0.586-0.836) | 0.858 (0.708-1.01) | 0.974 (0.793-1.15) | 1.10 (0.876-1.29) | 1.22 (0.958-1.43) | 1.39 (1.06-1.63) | 1.51 (1.14-1.79) |
| 3-hr | 0.254 (0.214-0.310) | 0.325 (0.275-0.399) | 0.425 (0.358-0.518) | 0.505 (0.421-0.611) | 0.616 (0.506-0.741) | 0.705 (0.571-0.843) | 0.797 (0.634-0.953) | 0.894 (0.700-1.07) | 1.03 (0.779-1.23) | 1.13 (0.840-1.36) |
| 6-hr | 0.153 (0.132-0.182) | 0.194 (0.166-0.230) | 0.247 (0.212-0.292) | 0.291 (0.246-0.341) | 0.349 (0.292-0.408) | 0.395 (0.325-0.460) | 0.442 (0.359-0.514) | 0.491 (0.391-0.572) | 0.557 (0.433-0.649) | 0.610 (0.462-0.711) |
| 12-hr | 0.084 (0.073-0.099) | 0.106 (0.092-0.125) | 0.134 (0.116-0.157) | 0.156 (0.134-0.183) | 0.186 (0.157-0.217) | 0.209 (0.174-0.242) | 0.232 (0.191-0.269) | 0.256 (0.208-0.297) | 0.288 (0.228-0.335) | 0.312 (0.243-0.367) |
| 24-hr | 0.050 (0.043-0.058) | 0.063 (0.055-0.074) | 0.081 (0.070-0.095) | 0.096 (0.083-0.112) | 0.116 (0.100-0.136) | 0.132 (0.112-0.154) | 0.148 (0.125-0.173) | 0.165 (0.139-0.193) | 0.189 (0.156-0.221) | 0.208 (0.170-0.243) |
| 2-day | 0.027 (0.023-0.031) | 0.034 (0.030-0.040) | 0.044 (0.039-0.052) | 0.053 (0.046-0.061) | 0.064 (0.055-0.075) | 0.074 (0.063-0.085) | 0.083 (0.070-0.097) | 0.093 (0.078-0.109) | 0.107 (0.089-0.125) | 0.119 (0.097-0.139) |
| 3-day | 0.019 (0.017-0.022) | 0.024 (0.021-0.028) | 0.032 (0.028-0.037) | 0.038 (0.033-0.044) | 0.047 (0.040-0.054) | 0.053 (0.046-0.062) | 0.061 (0.052-0.070) | 0.068 (0.058-0.079) | 0.079 (0.066-0.092) | 0.088 (0.072-0.102) |
| 4-day | 0.015 (0.013-0.017) | 0.019 (0.017-0.022) | 0.025 (0.022-0.029) | 0.030 (0.026-0.035) | 0.038 (0.032-0.043) | 0.043 (0.037-0.050) | 0.049 (0.042-0.057) | 0.056 (0.047-0.064) | 0.065 (0.054-0.075) | 0.072 (0.060-0.084) |
| 7-day | 0.010 (0.008-0.011) | 0.012 (0.011-0.014) | 0.016 (0.014-0.019) | 0.020 (0.017-0.023) | 0.024 (0.021-0.028) | 0.028 (0.024-0.032) | 0.032 (0.027-0.037) | 0.036 (0.030-0.042) | 0.042 (0.035-0.049) | 0.047 (0.038-0.054) |
| 10-day | 0.007 (0.006-0.008) | 0.009 (0.008-0.011) | 0.012 (0.011-0.014) | 0.015 (0.013-0.017) | 0.018 (0.016-0.021) | 0.021 (0.018-0.024) | 0.024 (0.020-0.027) | 0.027 (0.023-0.031) | 0.031 (0.026-0.036) | 0.035 (0.029-0.040) |
| 20-day | 0.005 (0.004-0.005) | 0.006 (0.005-0.007) | 0.008 (0.007-0.009) | 0.009 (0.008-0.010) | 0.011 (0.010-0.013) | 0.012 (0.011-0.014) | 0.014 (0.012-0.016) | 0.016 (0.013-0.018) | 0.018 (0.015-0.020) | 0.019 (0.016-0.022) |
| 30-day | 0.004 (0.003-0.004) | 0.005 (0.004-0.005) | 0.006 (0.005-0.007) | 0.007 (0.006-0.008) | 0.009 (0.007-0.010) | 0.010 (0.008-0.011) | 0.011 (0.009-0.012) | 0.012 (0.010-0.014) | 0.014 (0.012-0.016) | 0.015 (0.013-0.017) |
| 45-day | 0.003 (0.002-0.003) | 0.003 (0.003-0.004) | 0.005 (0.004-0.005) | 0.005 (0.005-0.006) | 0.007 (0.006-0.007) | 0.007 (0.006-0.008) | 0.008 (0.007-0.009) | 0.009 (0.008-0.010) | 0.010 (0.009-0.011) | 0.011 (0.009-0.012) |
| 60-day | 0.002 (0.002-0.003) | 0.003 (0.003-0.003) | 0.004 (0.003-0.004) | 0.004 (0.004-0.005) | 0.005 (0.005-0.006) | 0.006 (0.005-0.007) | 0.007 (0.006-0.007) | 0.007 (0.006-0.008) | 0.008 (0.007-0.009) | 0.009 (0.007-0.010) |

¹ Precipitation frequency (PF) estimates in this table are based on frequency analysis of partial duration series (PDS). Numbers in parenthesis are PF estimates at lower and upper bounds of the 90% confidence interval. The probability that precipitation frequency estimates (for a given duration and average recurrence interval) will be greater than the upper bound (or less than the lower bound) is 5%. Estimates at upper bounds are not checked against probable maximum precipitation (PMP) estimates and may be higher than currently valid PMP values. Please refer to NOAA Atlas 14 document for more information.

[Back to Top](#)

PF graphical



Appendix D – DETAILED DRAINAGE CALCULATIONS



Gold Dust Apartments
DIBBLE PROJECT NO. 1122028
ON-SITE DRAINAGE CALCULATIONS

DES: KR
 DATE: 2023-0417

HYDROLOGY CALCULATIONS

| DRAINAGE AREA | TOTAL AREA [SF] | WEIGHTED COEFFICIENT | *RAINFALL DEPTH [IN] | VOLUME REQUIRED [CF] |
|------------------|-----------------------|-------------------------|----------------------------|----------------------------|
| A | 156,124 | 1.00 | 0.50 | 6,505 |
| TOTAL | 156,124 | | | 6,505 |

UNDERGROUND RETENTION

| REQUIRED VOLUME [CF] | MODULE HEIGHT [FT] | MODULES REQUIRED | MODULES PROVIDED | TOTAL VOLUME [CF] | NUMBER OF DRYWELLS | DRAIN TIME [HR] |
|---|--------------------------|---------------------|---------------------|-------------------------|-----------------------|-----------------------|
| 6,505.2 | 14.0 | 4.4 | 5.0 | 7,350 | | |
| TOTAL | | | | 7,350 | 1 | 18.1 |
| **Assumed Drywell Percolation Rate [CFS]: | | | | 0.10 | | |

$$No. of Drywells Required = \frac{Volume\ Required\ [CF]}{Percolation\ Rate\ [CFS]} * \frac{1\ hour}{3600\ seconds} * \frac{1}{Allowable\ Drain\ Time\ [hrs]}$$

STORMCAPTURE SPECS

| MIN HEIGHT [FT] | MAX HEIGHT [FT] | MODULE WIDTH [FT] | MODULE LENGTH [FT] | MAX MODULE VOLUME [CF] |
|-----------------------|-----------------------|-------------------------|--------------------------|------------------------------|
| 2.0 | 14.0 | 7.0 | 15.0 | 1,470 |



Gold Dust Apartments

DIBBLE PROJECT NO. 1122028

PRE VS POST DEVELOPEMNT VOLUME CALCULATIONS

DES: KR

DATE: 2023-0417

HYDROLOGY CALCULATIONS

| DRAINAGE AREA | TOTAL AREA [SF] | GRAVELED SURFACES [SF] | PAVEMENT & BUILDING [SF] | WEIGHTED COEFFICIENT | *RAINFALL DEPTH [IN] | VOLUME REQUIRED [CF] |
|---------------|-----------------|------------------------|--------------------------|----------------------|----------------------|----------------------|
| | | 0.45 | 0.95 | | | |

PRE CONSTRUCTION 100-YEAR, 2-HOUR

| | | | | | | |
|--------------|---------|--------|---------|------|------|---------------|
| A | 156,124 | 14,845 | 141,279 | 0.90 | 2.19 | 25,713 |
| TOTAL | | | | | | 25,713 |

POST CONSTRUCTION 100-YEAR, 2-HOUR

| | | | | | | |
|--------------|---------|--------|---------|------|------|---------------|
| A | 156,124 | 24,148 | 131,976 | 0.87 | 2.19 | 24,865 |
| TOTAL | | | | | | 24,865 |

| | |
|--------------------|-------------|
| PRE VS POST | -849 |
|--------------------|-------------|



Appendix E – UNNAMED CHANNEL FIELD PHOTOGRAPHS



Photo 1: Looking North, upstream of Unnamed Wash. The channels material is shotcrete. Trash and other debris can be seen in the main channel.



Photo 2: Looking South, downstream of Unnamed Wash. Three box culverts are used to convey runoff under Gold Dust Avenue. Note the debris and sediment in each of the culverts.



Photo 3: Looking North, upstream of Unnamed Wash. Outlet side of the culverts passing under Gold Dust Avenue.



Photo 4: Looking South, downstream of Unnamed Wash. The channel banks are lined with grass and thick vegetation. The main flow channel has large rock and little vegetation growth.



Photo 5: Looking South, downstream of Unnamed Wash. Four box culverts convey runoff under a private driveway. Note the sediment and debris collected in the culverts.



Photo 6: Looking South, downstream of Unnamed Wash. Outlet side of the four box culverts.



Photo 7: Looking South, downstream of Unnamed Wash. The banks are lined with gravel and grass. The main flow channel is gravel and has some vegetation obstructions.



Photo 8: Looking North, upstream of Unnamed Wash. The vegetation gets denser. The other conditions remain the same.



Photo 9: Looking South, downstream of Unnamed Wash. Three box culverts convey runoff under Mountain View Road.



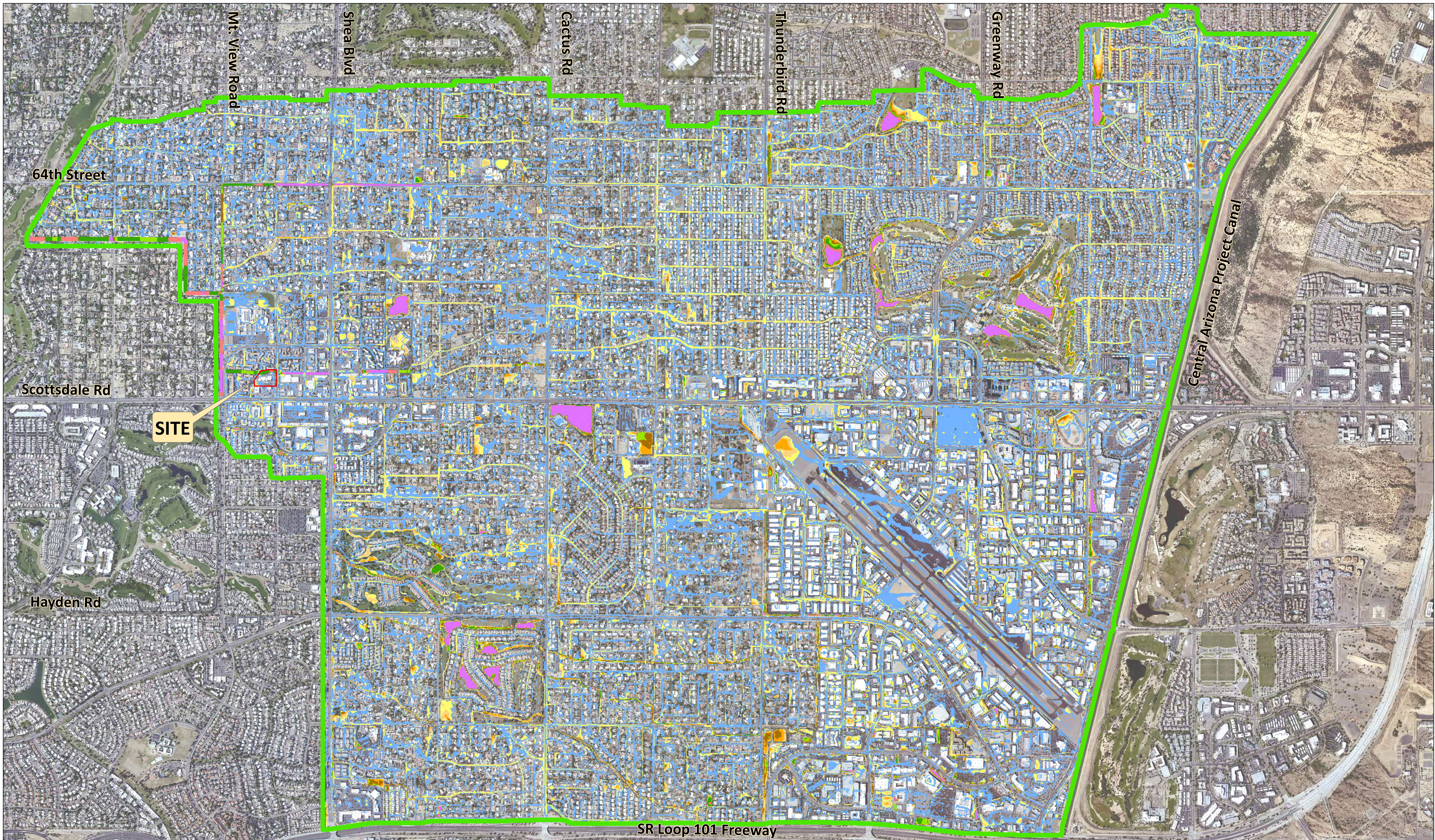
Photo 10: Looking North, upstream of Unnamed Wash. The outlet side of the three box culverts passing under Mountain View Road.



Photo 11: Looking West, downstream of outlet wash of Unnamed Wash.



Appendix F – OFF-SITE HYDROLOGY RESULTS (LARGE FORMAT)



SITE














| | | | | | | | |
|---|-----------------|---|-------------|---|-------------|---|--------------|
|  | Domain Boundary |  | Depth (ft) |  | 1.01 - 1.50 |  | 3.01 - 3.50 |
|  | Site Boundary |  | 0.08 - 0.16 |  | 1.51 - 2.00 |  | 3.51 - 4.00 |
| | |  | 0.17 - 0.50 |  | 2.01 - 2.50 |  | 4.01 - 25.00 |
| | |  | 0.51 - 1.00 |  | 2.51 - 3.00 | | |

Exhibit F-1

100-yr, 6-hr Storm, FLO-2D Maximum Depth

State the study this information is from.

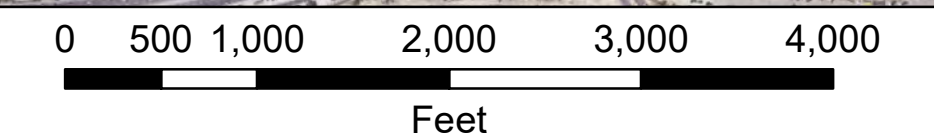


Exhibit F-1:100-yr, 6-hr Storm, FLO-2D Peak Discharge

Date Saved: 9/1/2022 6:49:04 PM



Appendix G – UNNAMED CHANNEL HYDRAULIC COMPUTATIONS



| Legend | |
|--|--------------------------------|
| ● | BANK STATION |
| --- | RIVER REACH |
| | ROADWAY CROSSING |
| | CROSS SECTION W/ RIVER STATION |
| | 100 YR INUNDATION |

GOLD DUST APARTMENTS - UNNAMED CHANNEL

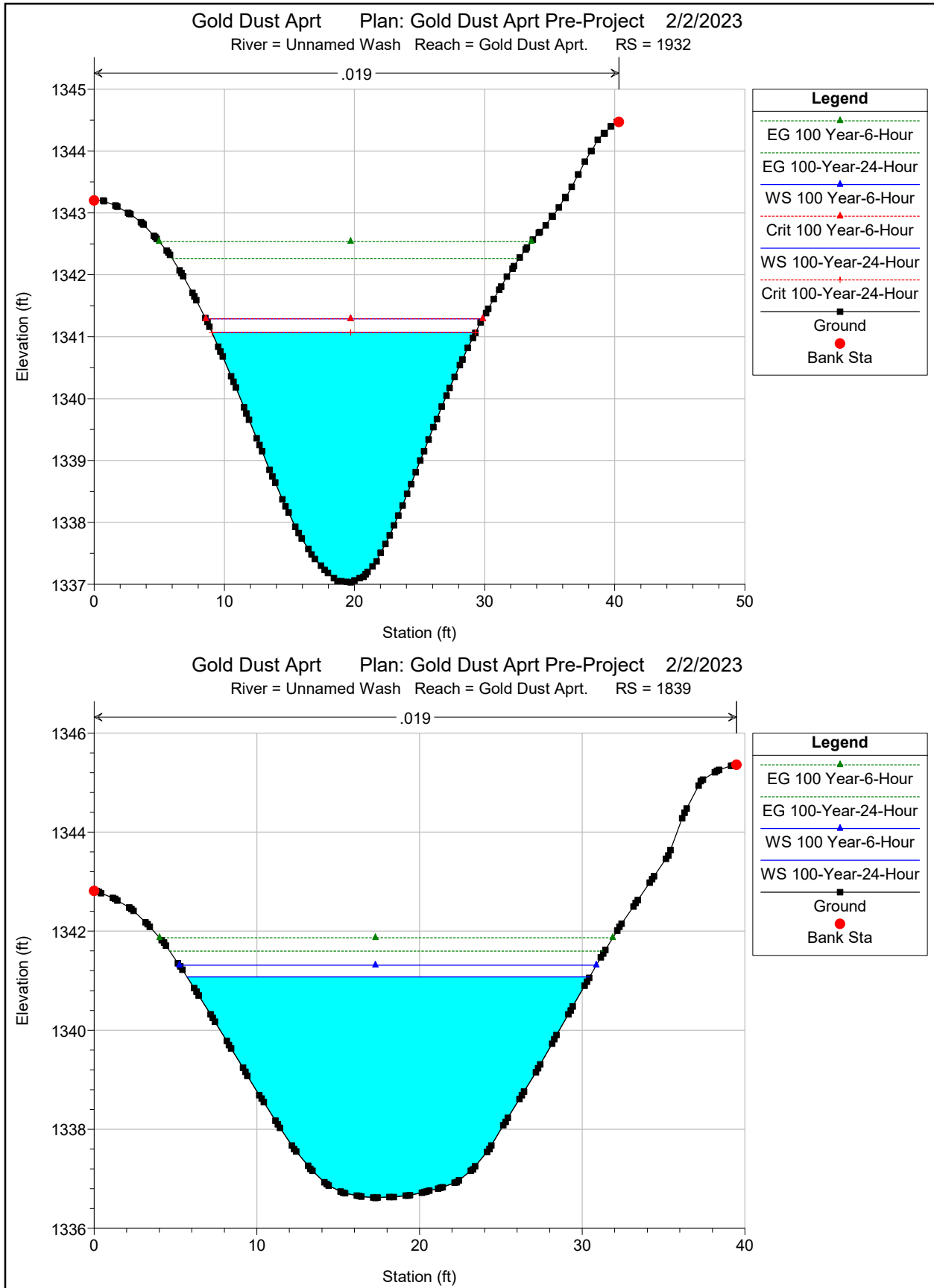
**Exhibit G-1
Existing Condition 100 Year Inundation**

0 75 150 300
Feet

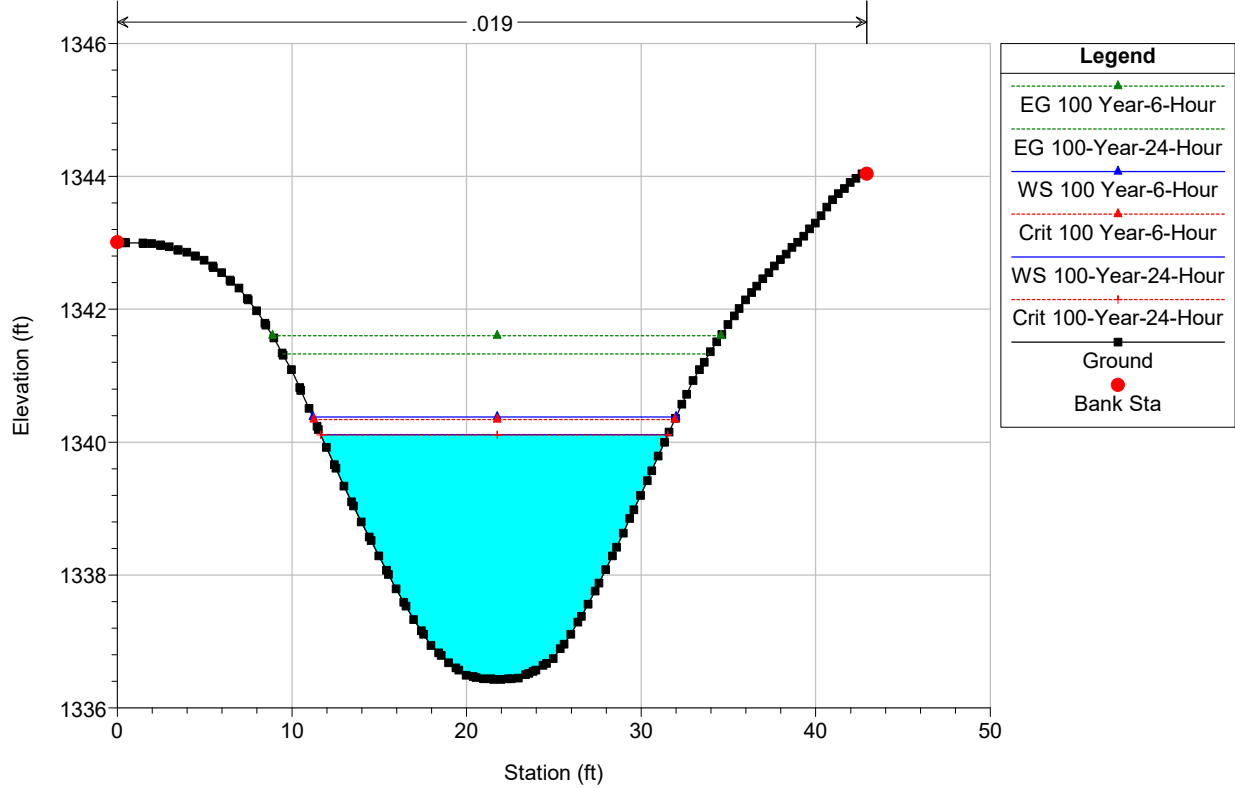
DIBBLE

Exhibit G-1: Existing Condition 100 Year Inundation

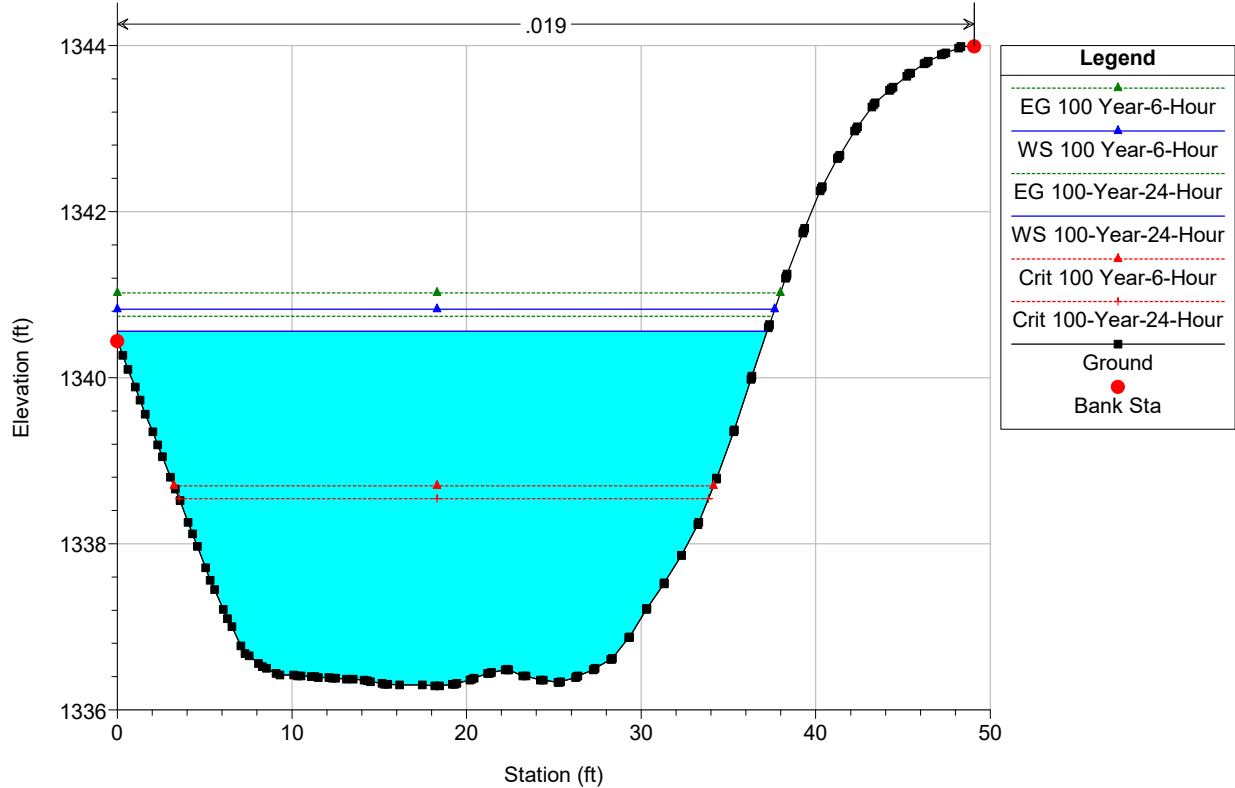
The n-value of 0.019 is not mentioned in the report. Where did it come from? Also, all bank stations are at the limits of the cross sections, please revise in final plans. (typ for all HEC-RAS)



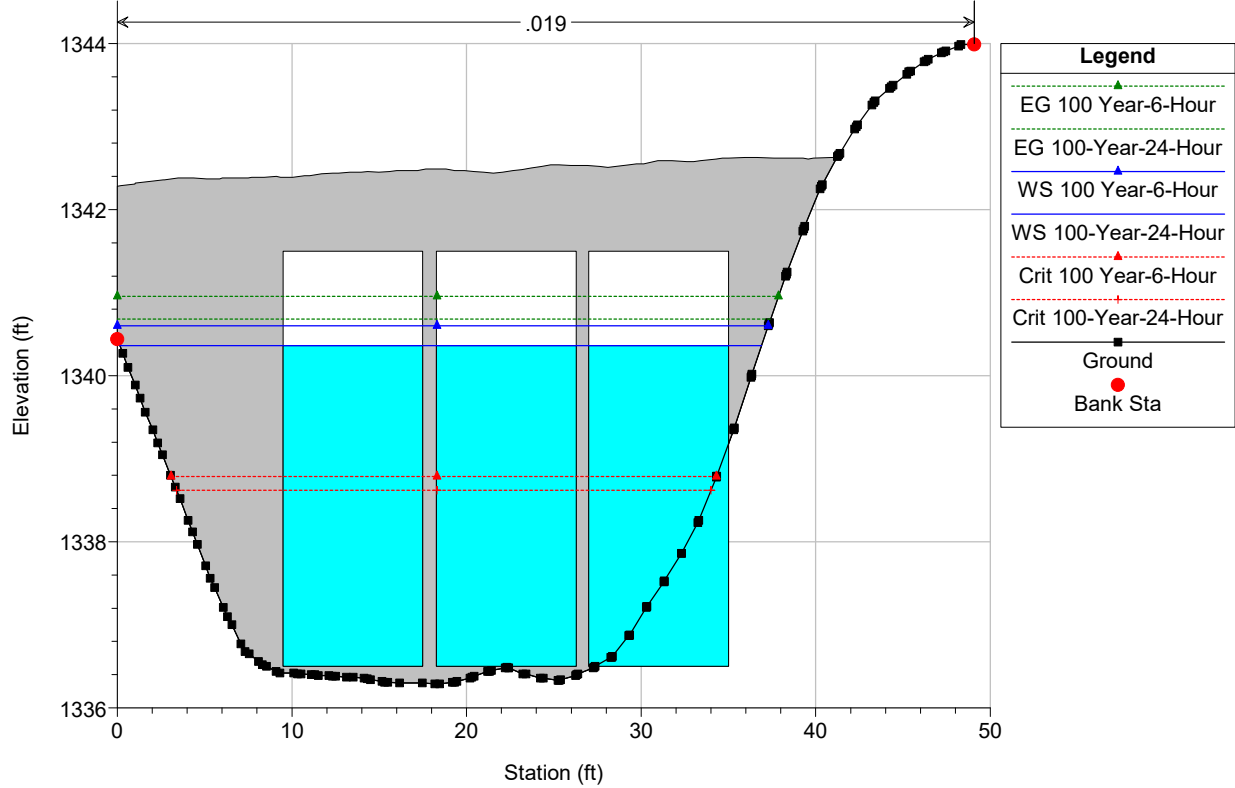
Gold Dust Aprt Plan: Gold Dust Aprt Pre-Project 2/2/2023
 River = Unnamed Wash Reach = Gold Dust Aprt. RS = 1753



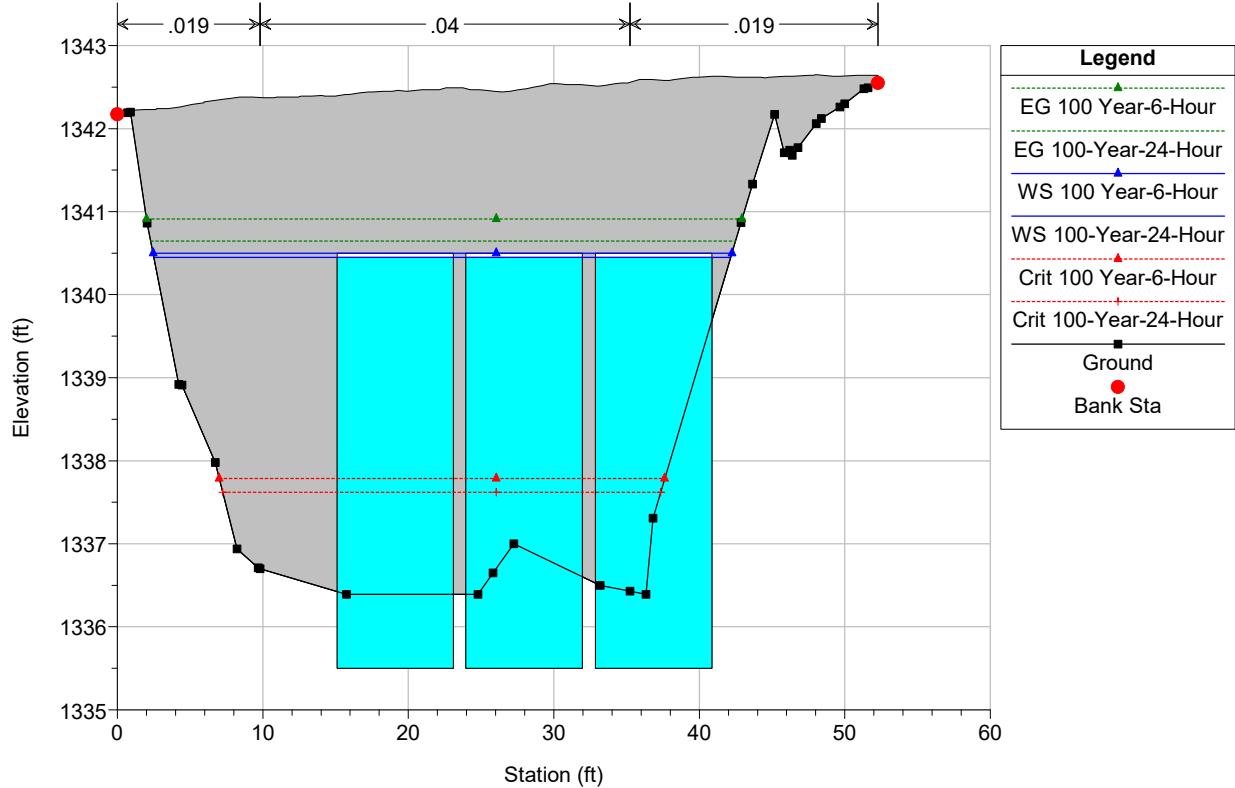
Gold Dust Aprt Plan: Gold Dust Aprt Pre-Project 2/2/2023
 River = Unnamed Wash Reach = Gold Dust Aprt. RS = 1682



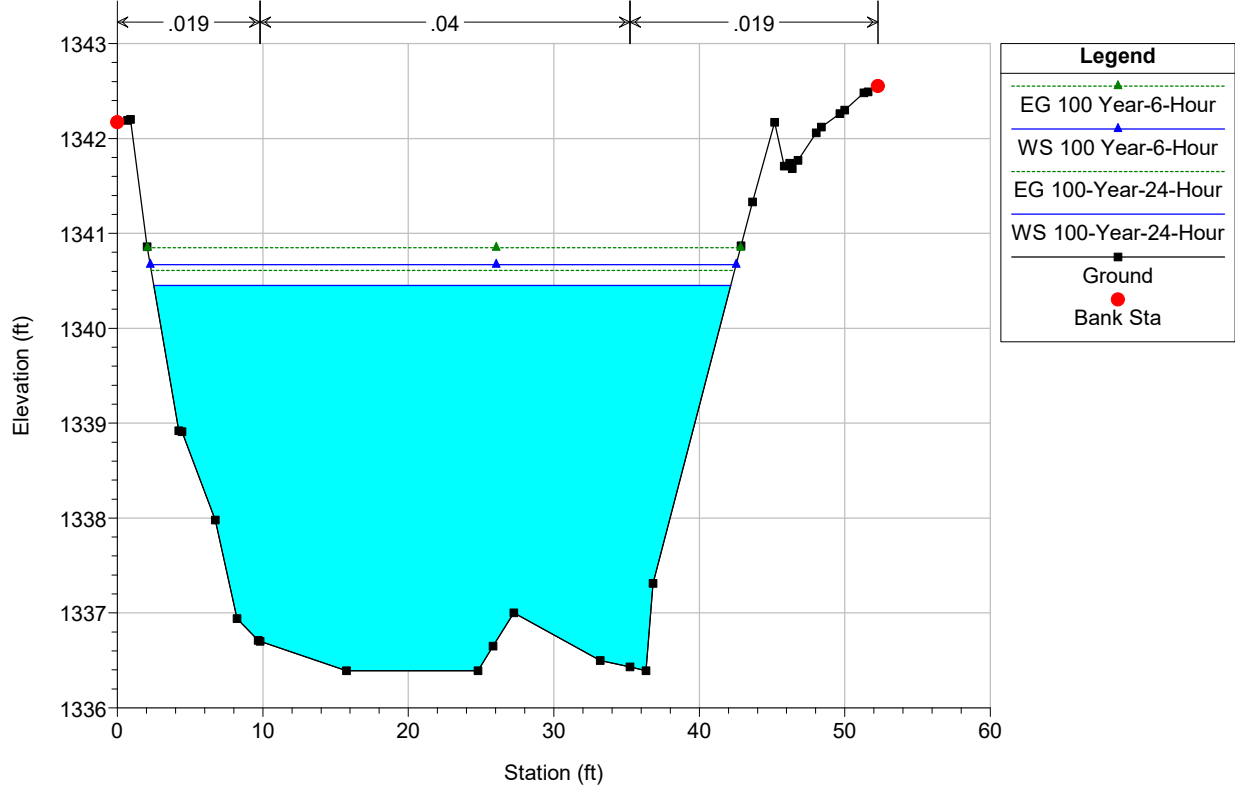
Gold Dust Aprt Plan: Gold Dust Aprt Pre-Project 2/2/2023
 River = Unnamed Wash Reach = Gold Dust Aprt. RS = 1628 Culv Gold Dust Avenue



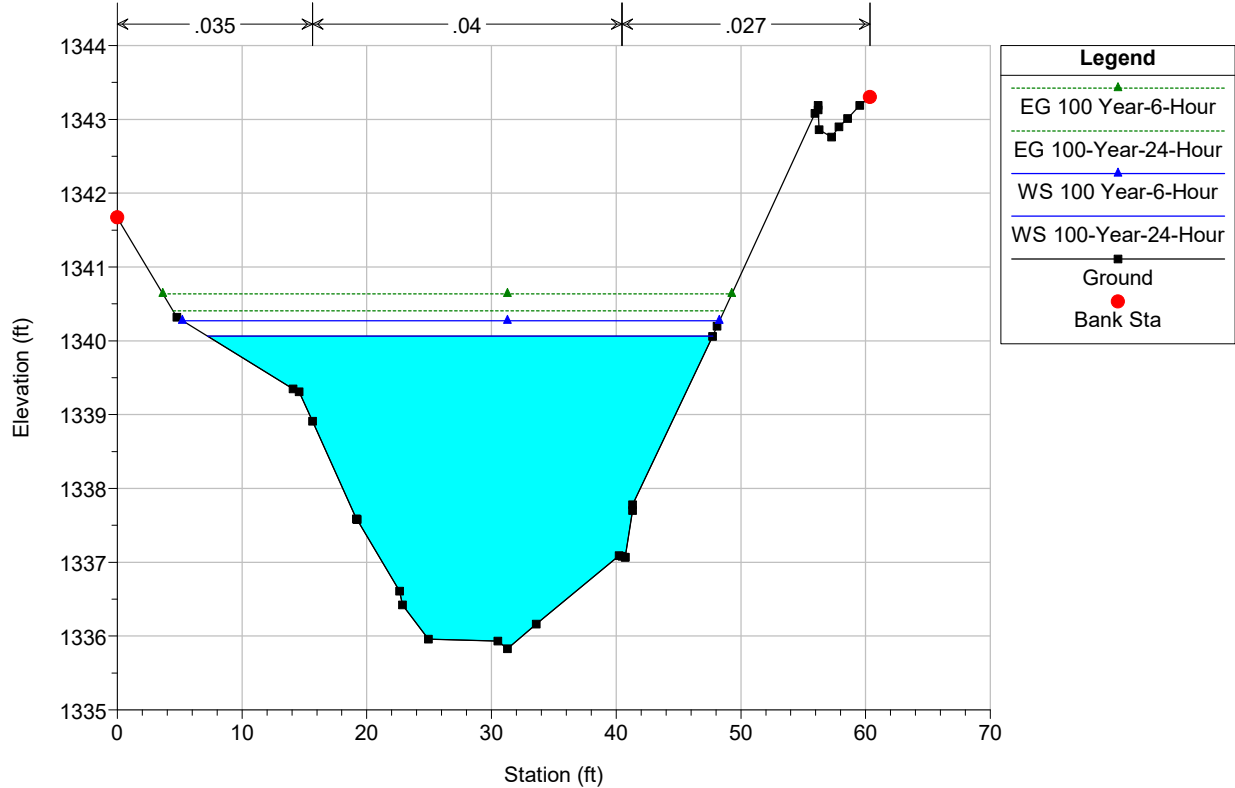
Gold Dust Aprt Plan: Gold Dust Aprt Pre-Project 2/2/2023
 River = Unnamed Wash Reach = Gold Dust Aprt. RS = 1628 Culv Gold Dust Avenue



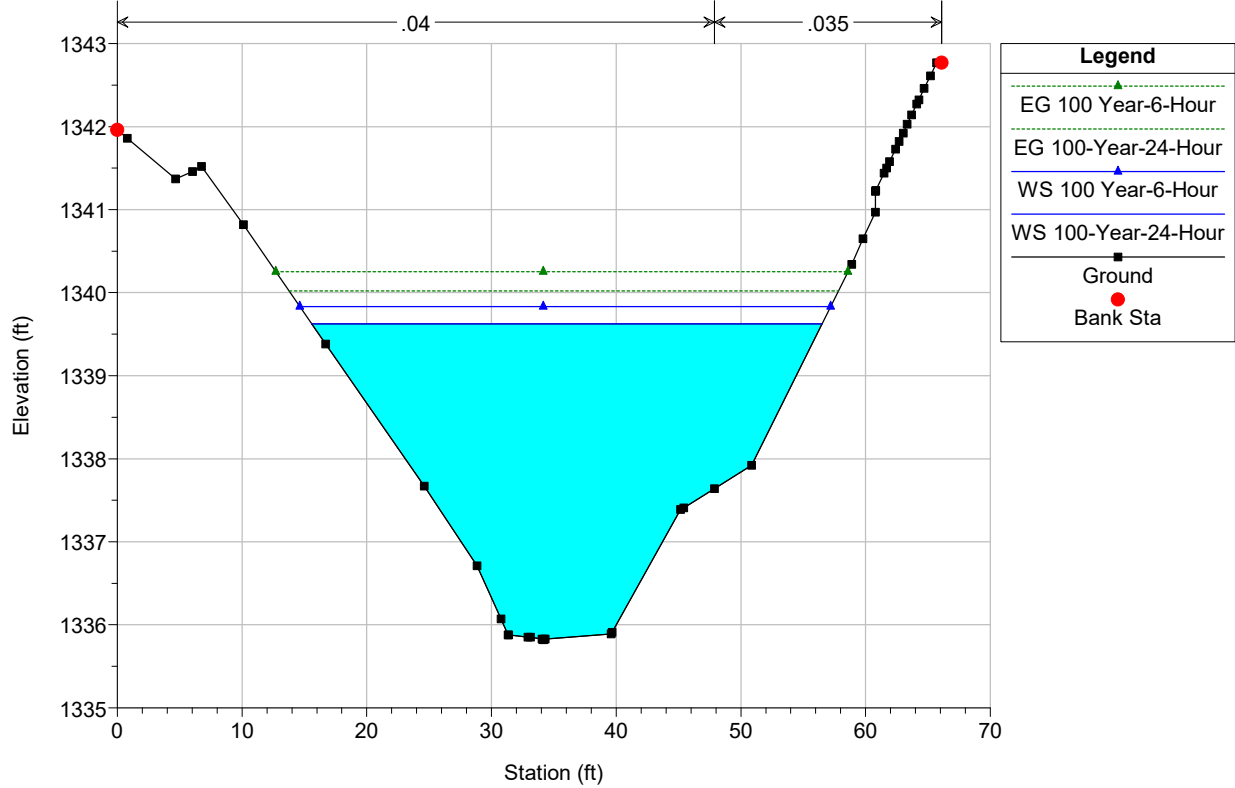
Gold Dust Aprt Plan: Gold Dust Aprt Pre-Project 2/2/2023
 River = Unnamed Wash Reach = Gold Dust Aprt. RS = 1572



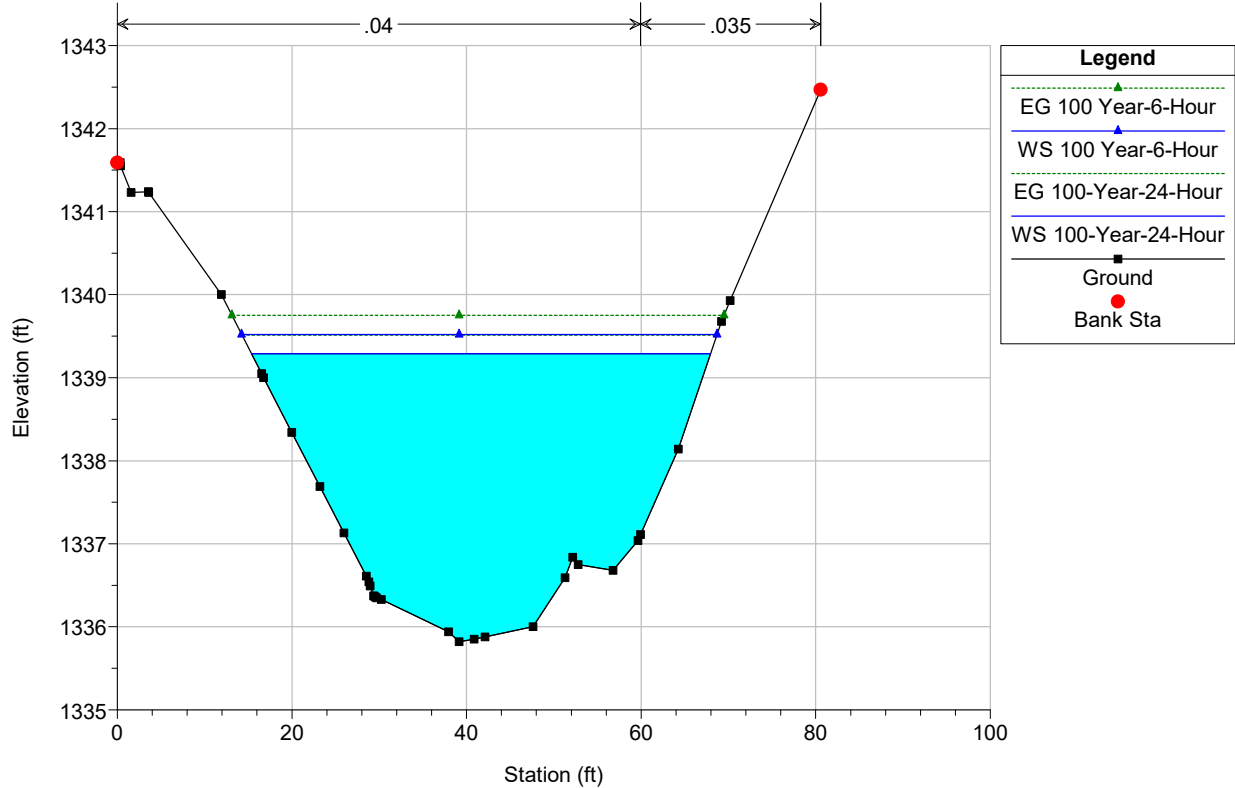
Gold Dust Aprt Plan: Gold Dust Aprt Pre-Project 2/2/2023
 River = Unnamed Wash Reach = Gold Dust Aprt. RS = 1496



Gold Dust Aprt Plan: Gold Dust Aprt Pre-Project 2/2/2023
 River = Unnamed Wash Reach = Gold Dust Aprt. RS = 1422

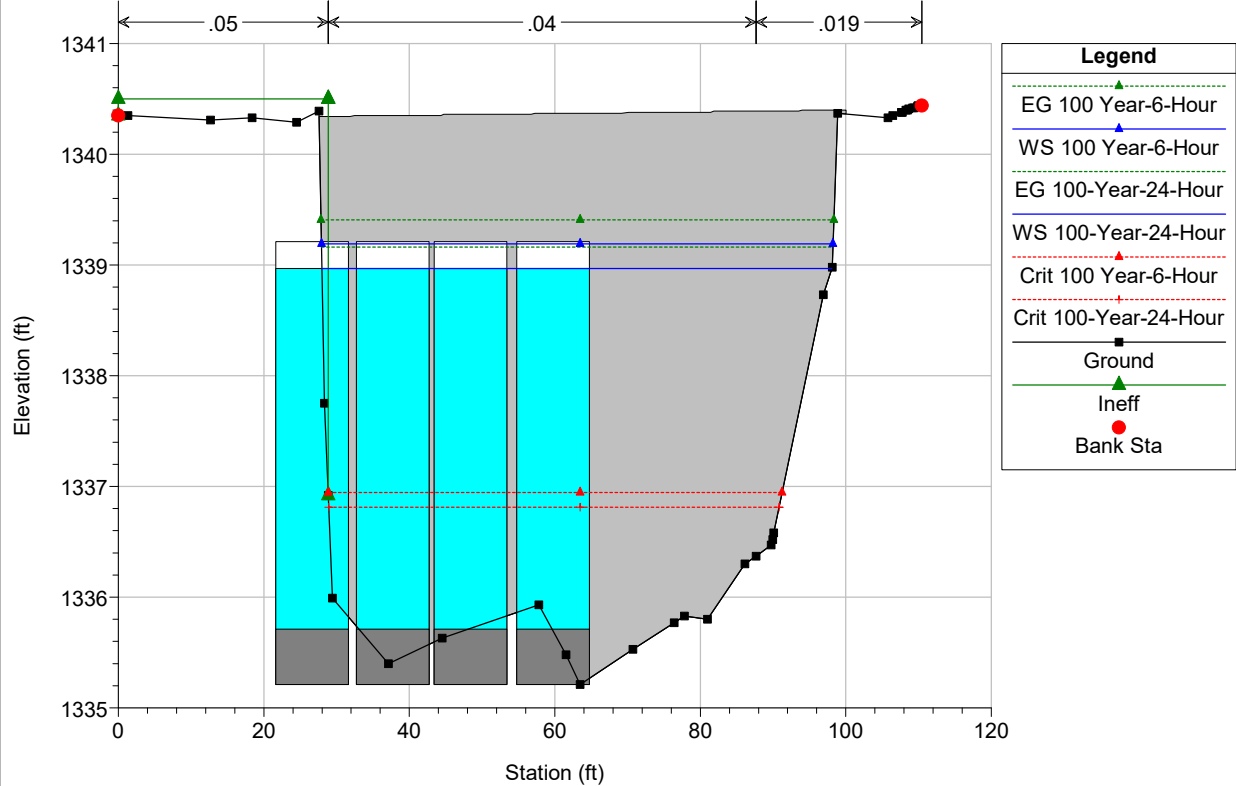


Gold Dust Aprt Plan: Gold Dust Aprt Pre-Project 2/2/2023
 River = Unnamed Wash Reach = Gold Dust Aprt. RS = 1319



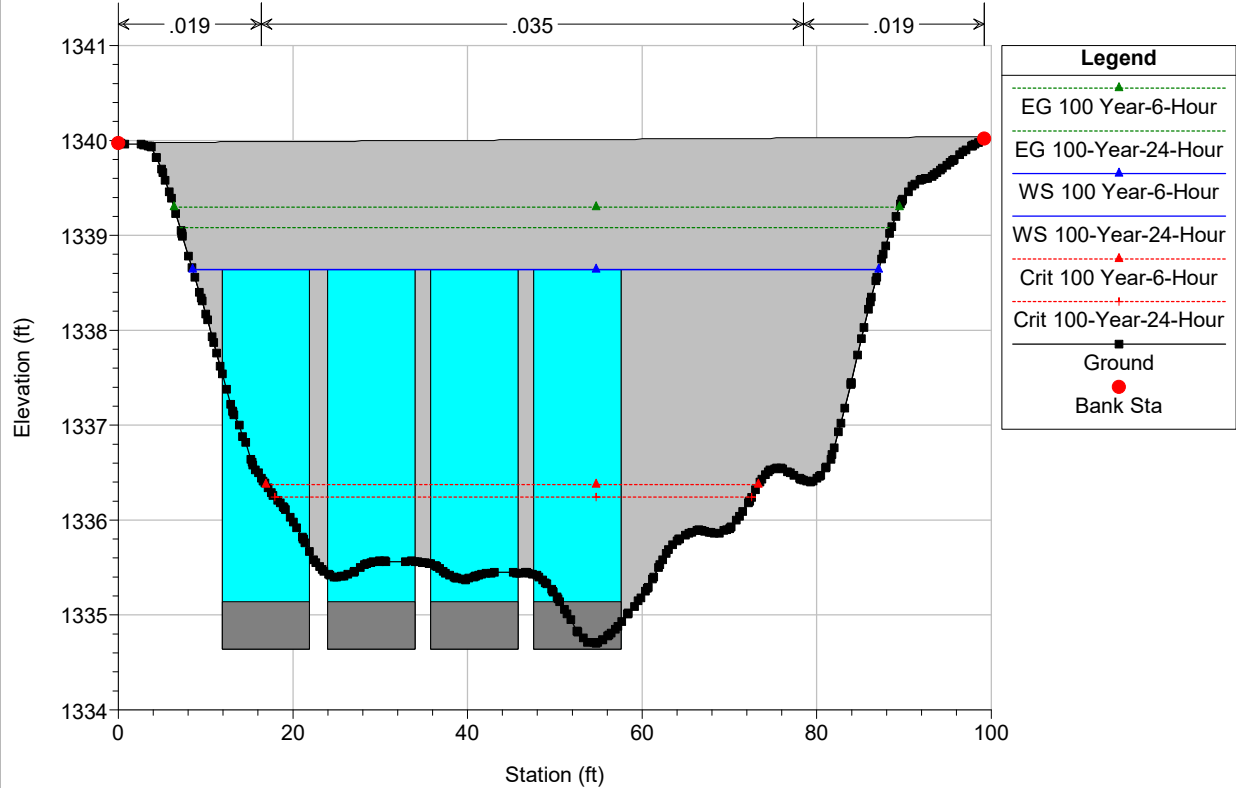
Gold Dust Aprt Plan: Gold Dust Aprt Pre-Project 2/2/2023

River = Unnamed Wash Reach = Gold Dust Aprt. RS = 1154 Culv Private Driveway

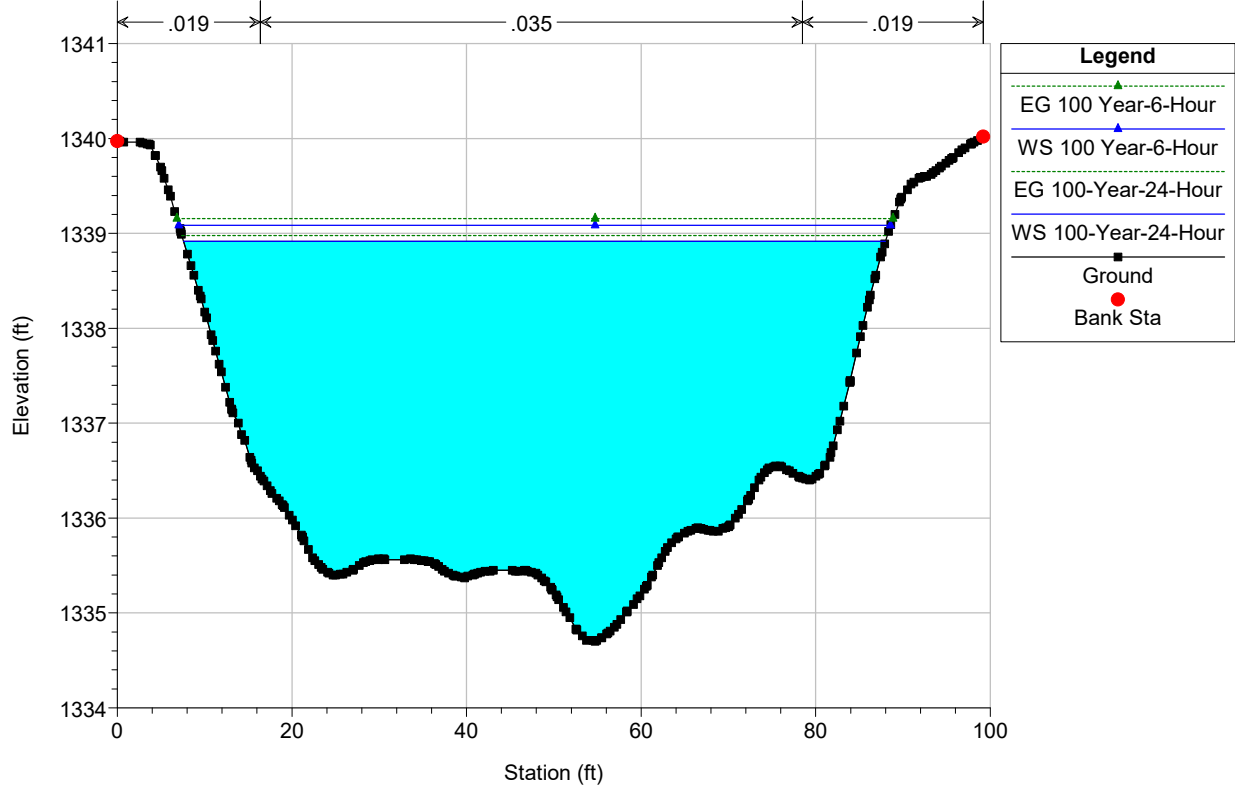


Gold Dust Aprt Plan: Gold Dust Aprt Pre-Project 2/2/2023

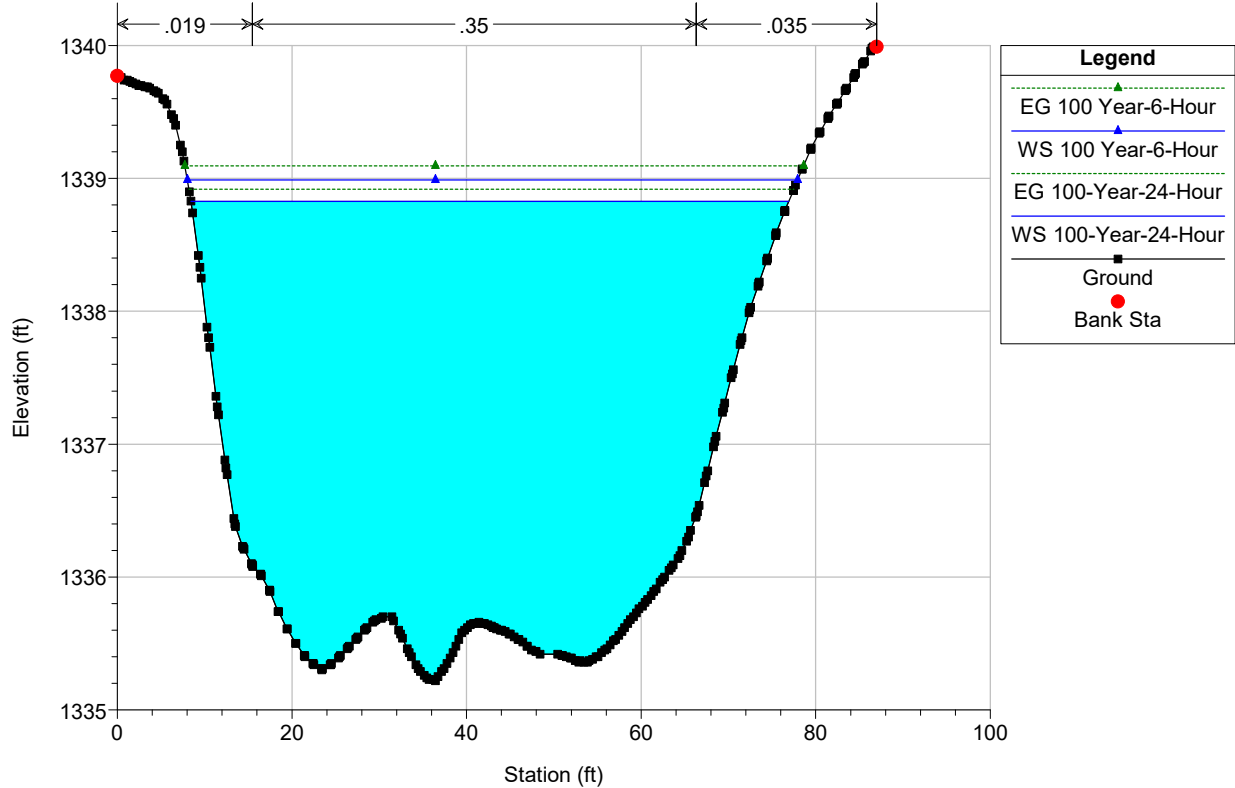
River = Unnamed Wash Reach = Gold Dust Aprt. RS = 1154 Culv Private Driveway



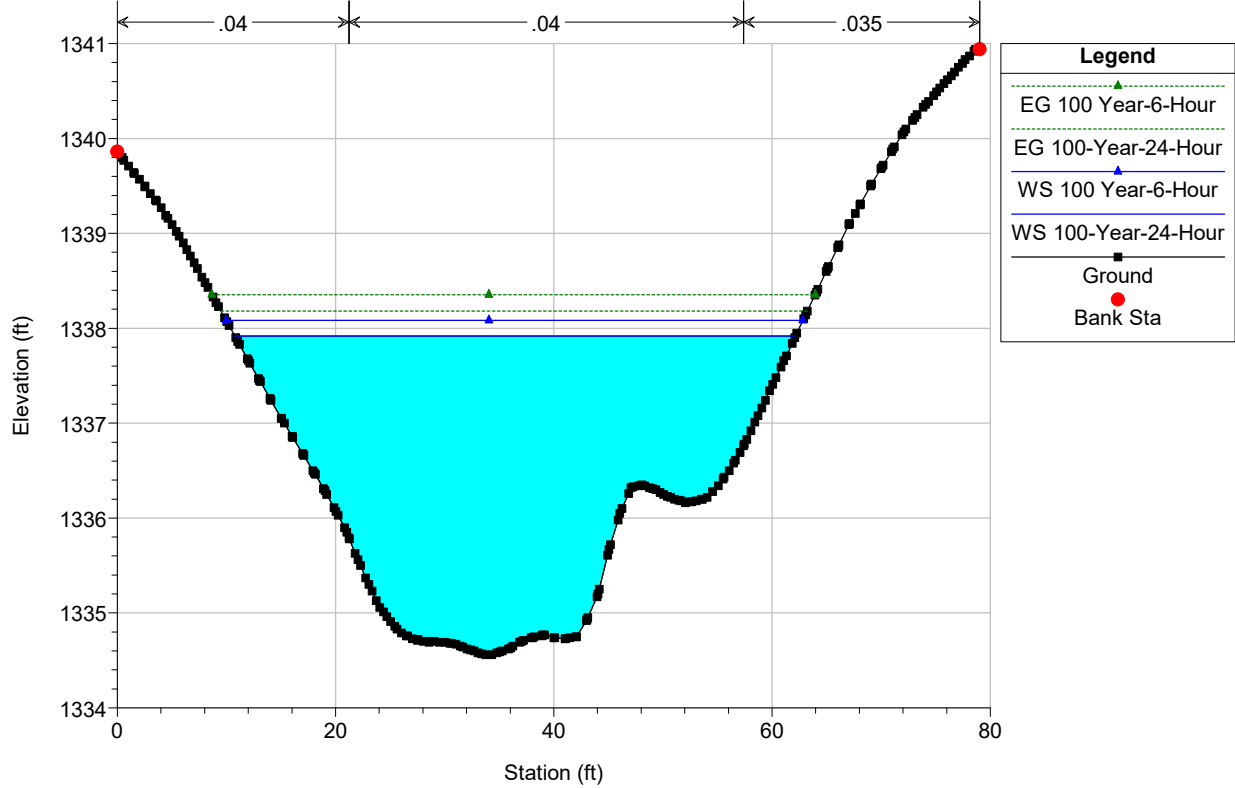
Gold Dust Aprt Plan: Gold Dust Aprt Pre-Project 2/2/2023
 River = Unnamed Wash Reach = Gold Dust Aprt. RS = 1118



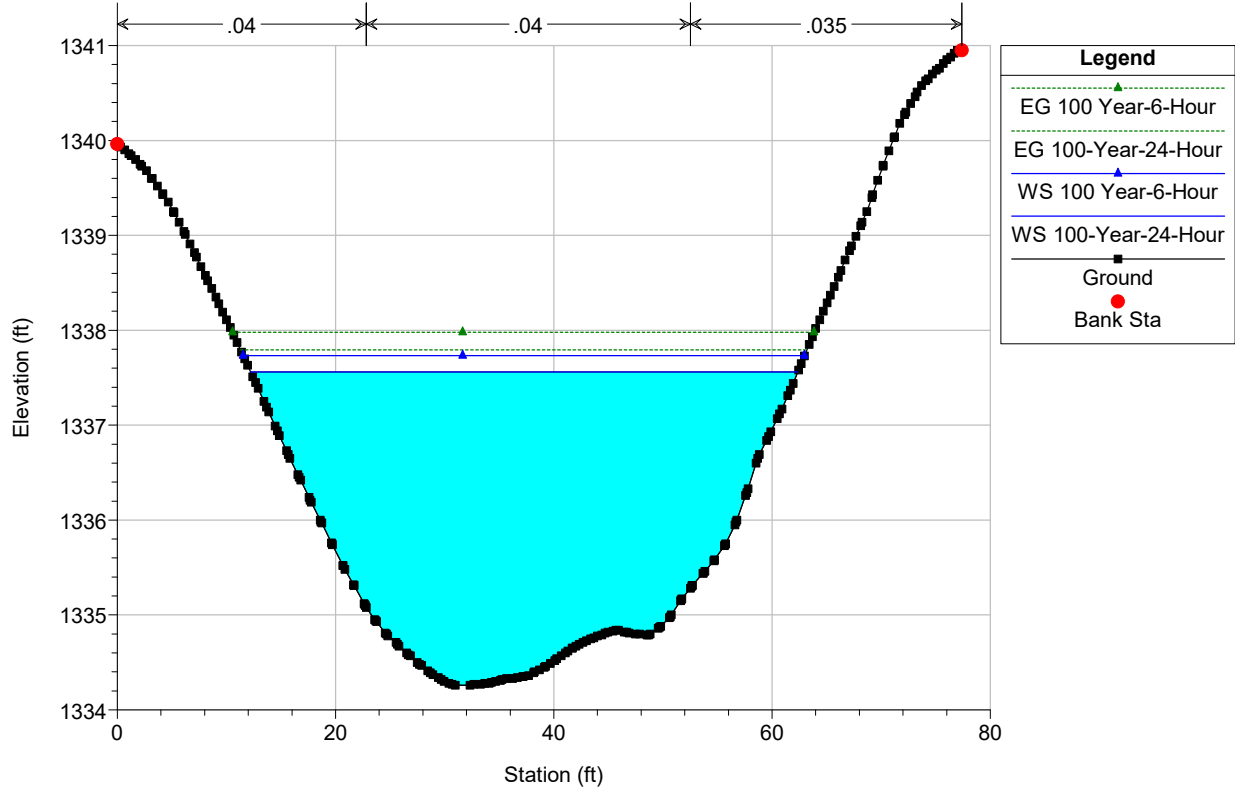
Gold Dust Aprt Plan: Gold Dust Aprt Pre-Project 2/2/2023
 River = Unnamed Wash Reach = Gold Dust Aprt. RS = 1087



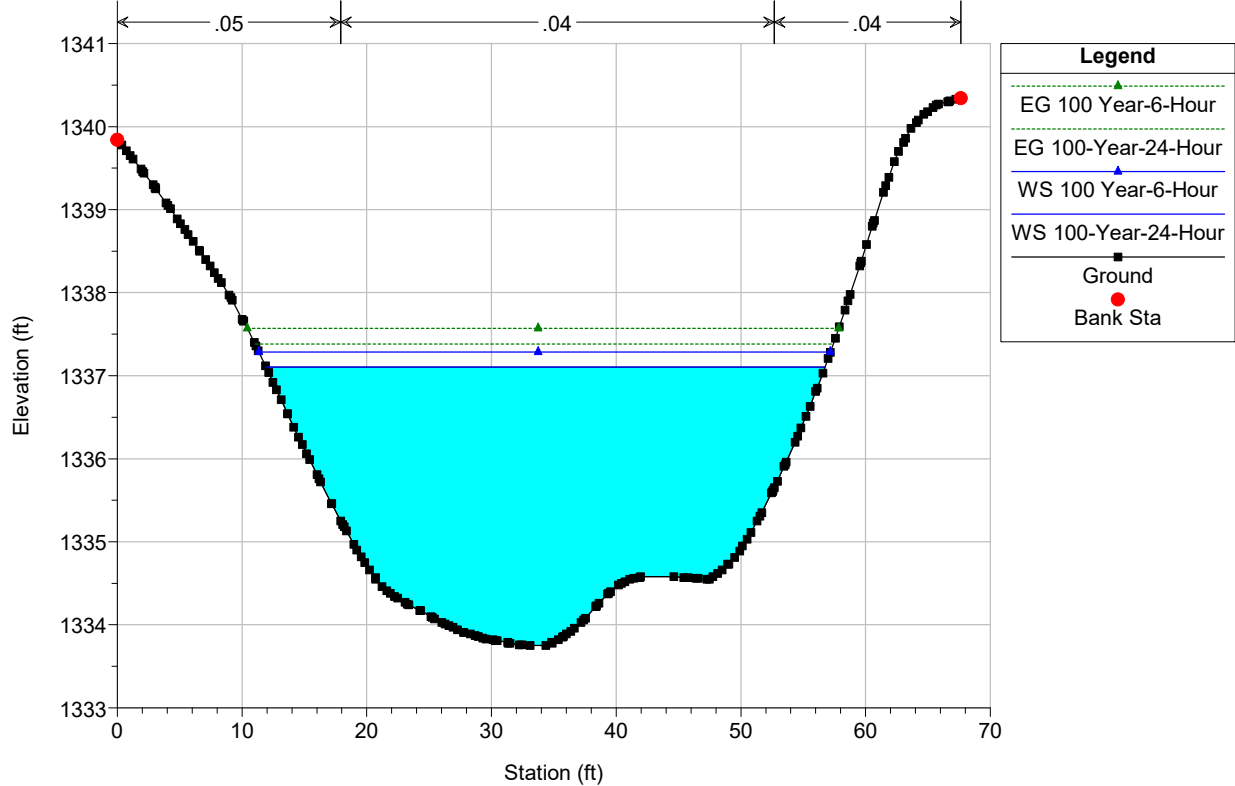
Gold Dust Aprt Plan: Gold Dust Aprt Pre-Project 2/2/2023
 River = Unnamed Wash Reach = Gold Dust Aprt. RS = 1016



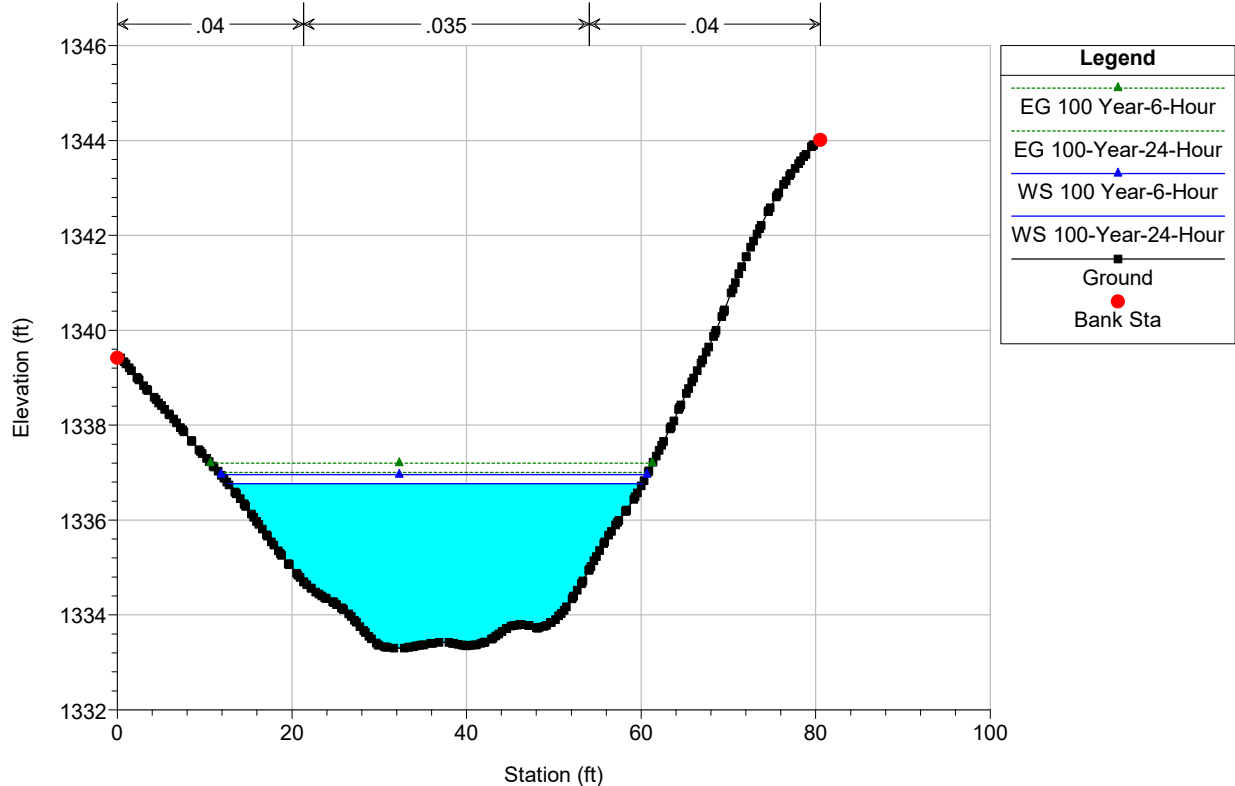
Gold Dust Aprt Plan: Gold Dust Aprt Pre-Project 2/2/2023
 River = Unnamed Wash Reach = Gold Dust Aprt. RS = 915



Gold Dust Aprt Plan: Gold Dust Aprt Pre-Project 2/2/2023
 River = Unnamed Wash Reach = Gold Dust Aprt. RS = 812

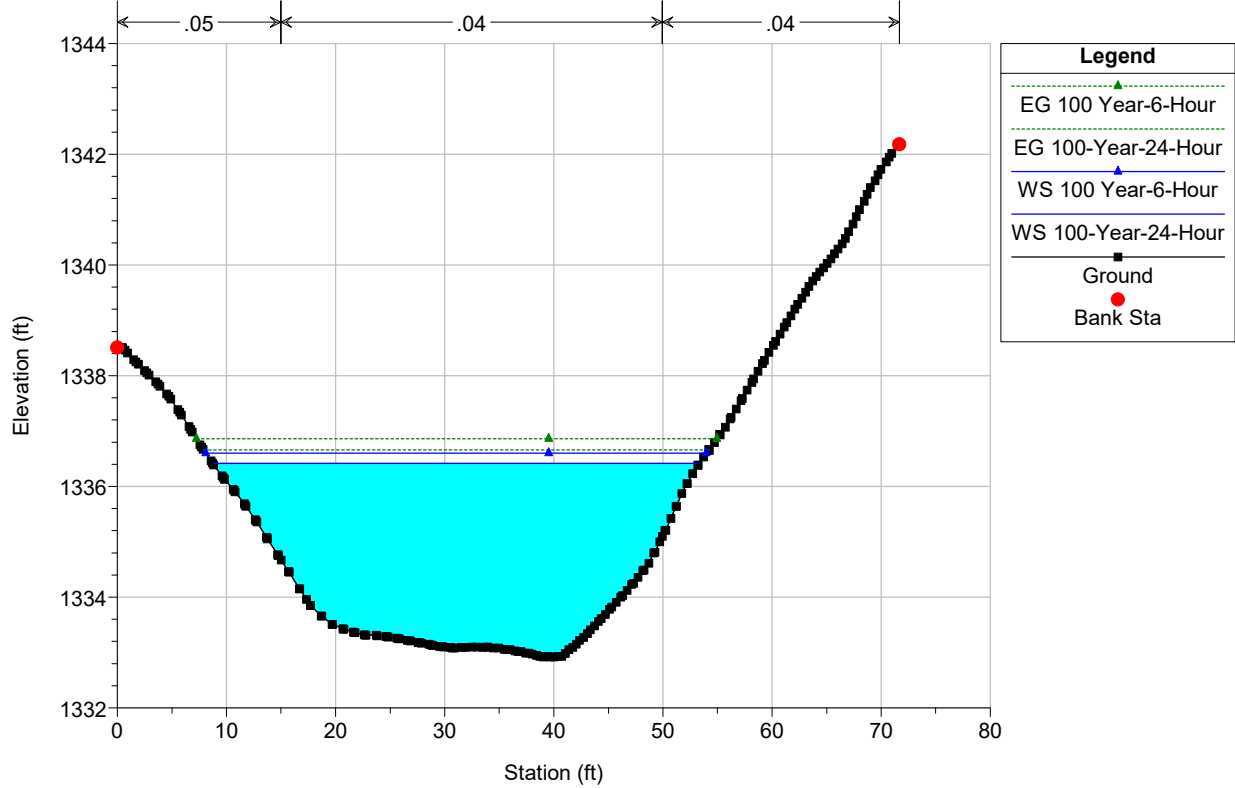


Gold Dust Aprt Plan: Gold Dust Aprt Pre-Project 2/2/2023
 River = Unnamed Wash Reach = Gold Dust Aprt. RS = 712



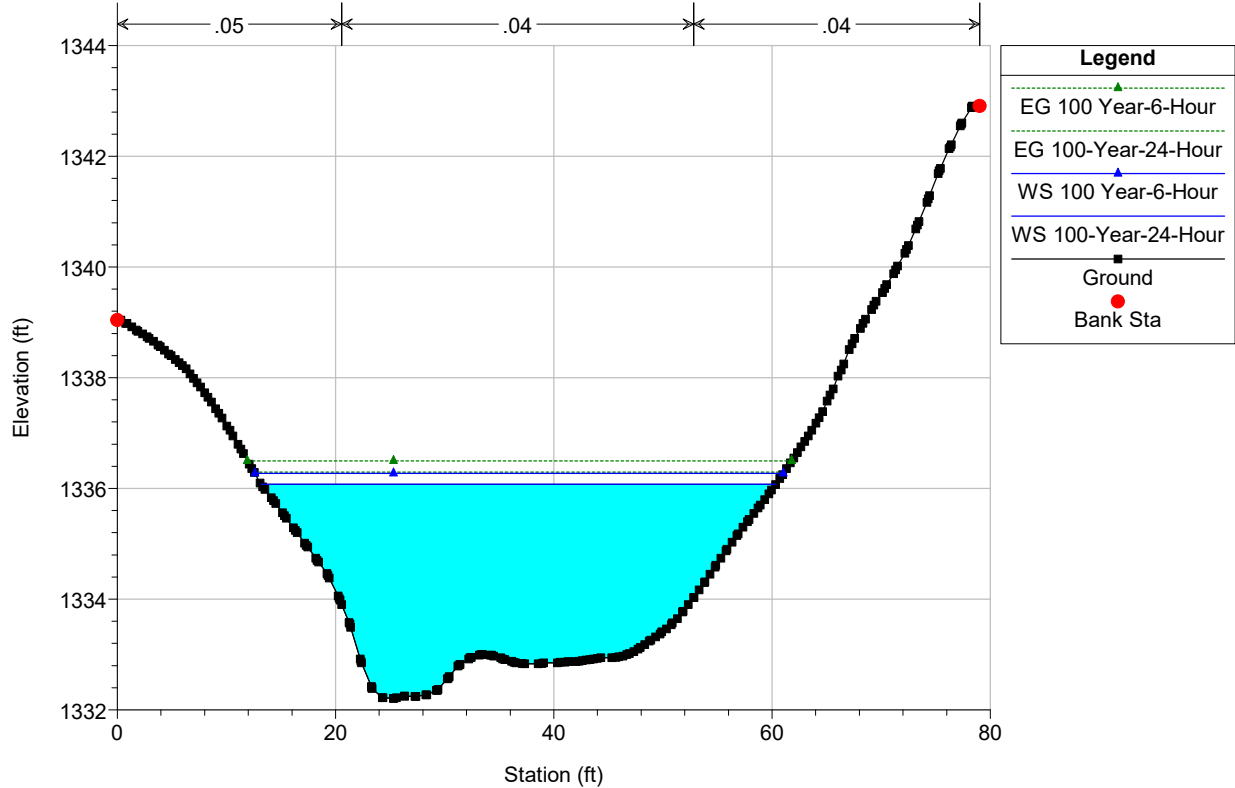
Gold Dust Aprt Plan: Gold Dust Aprt Pre-Project 2/2/2023

River = Unnamed Wash Reach = Gold Dust Aprt. RS = 609

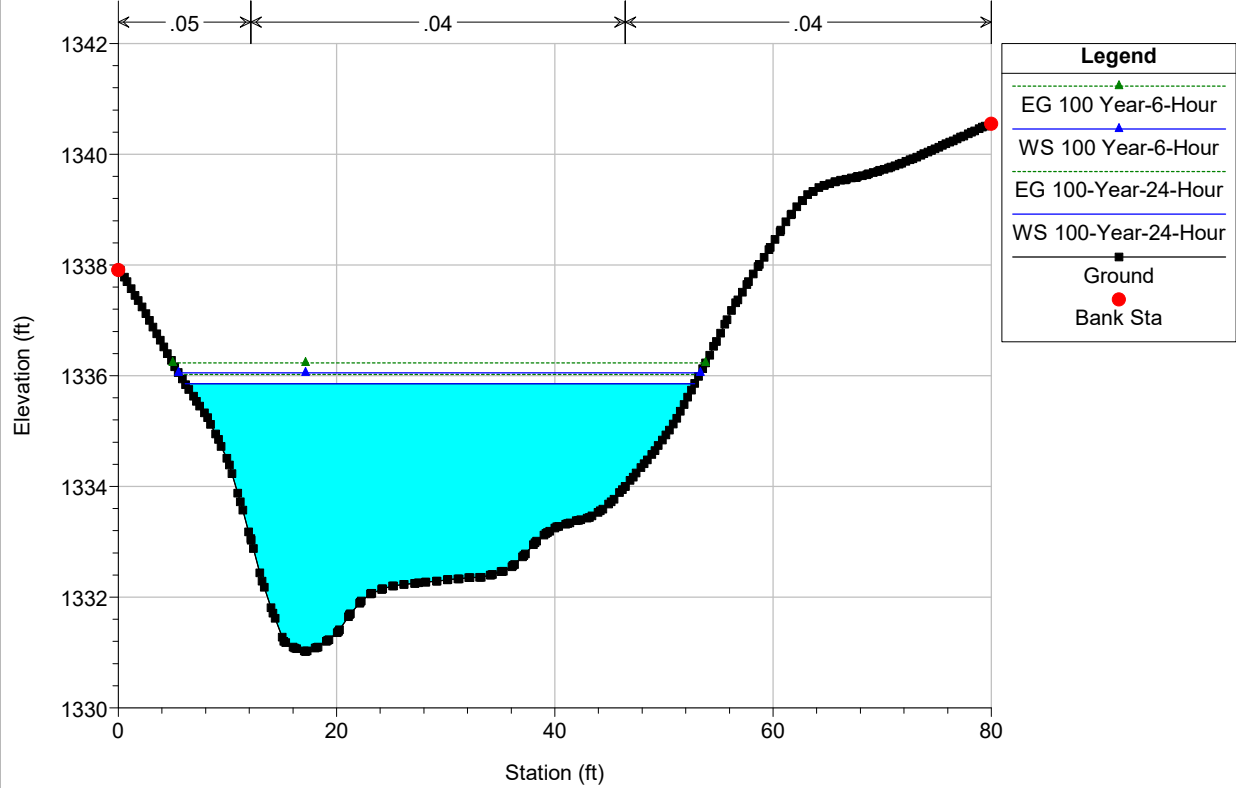


Gold Dust Aprt Plan: Gold Dust Aprt Pre-Project 2/2/2023

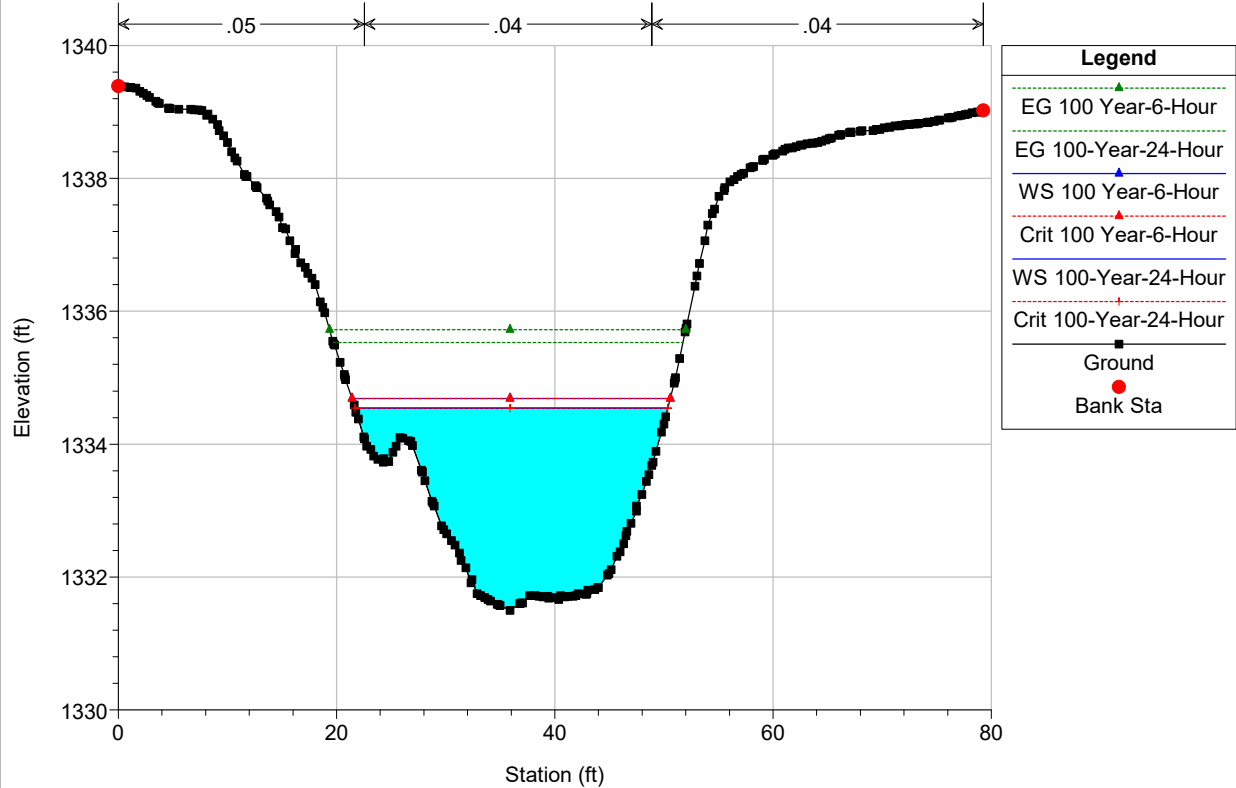
River = Unnamed Wash Reach = Gold Dust Aprt. RS = 508

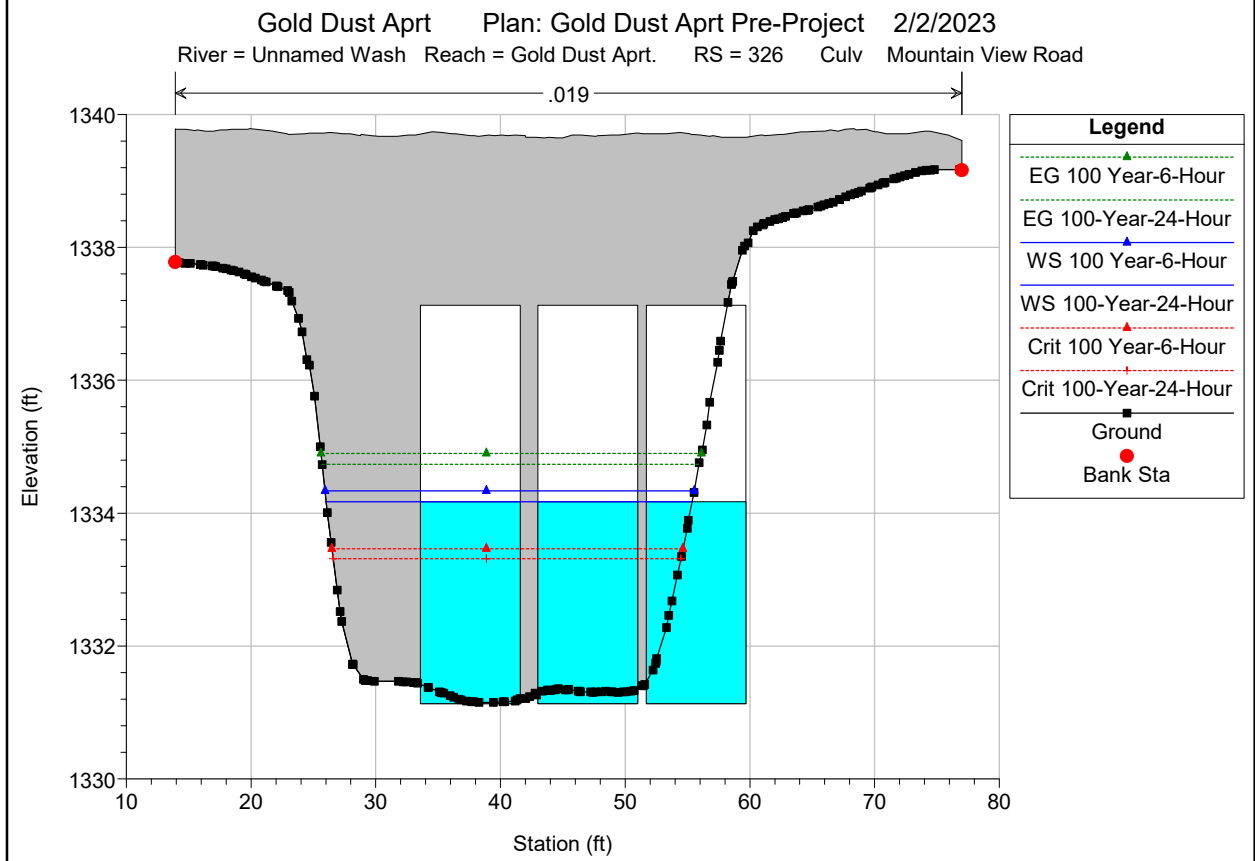
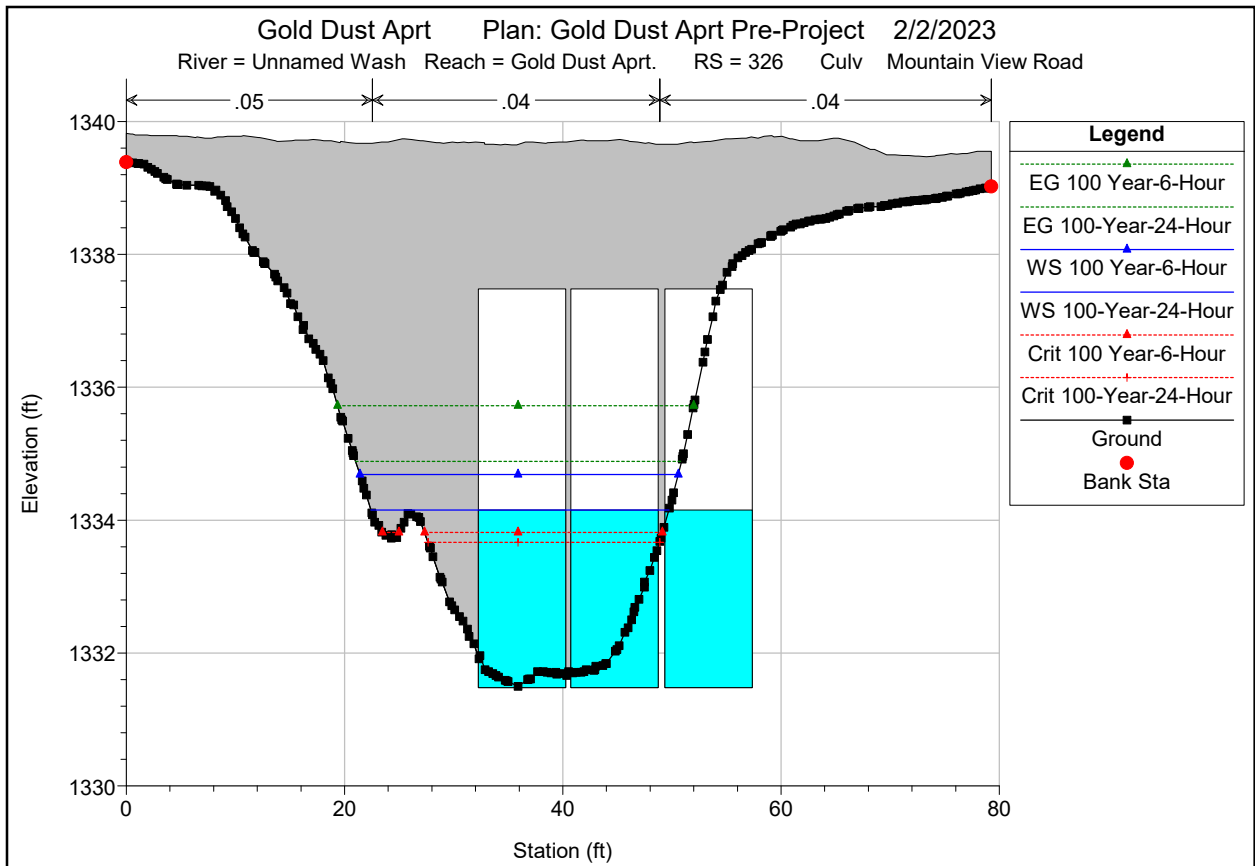


Gold Dust Aprt Plan: Gold Dust Aprt Pre-Project 2/2/2023
 River = Unnamed Wash Reach = Gold Dust Aprt. RS = 413

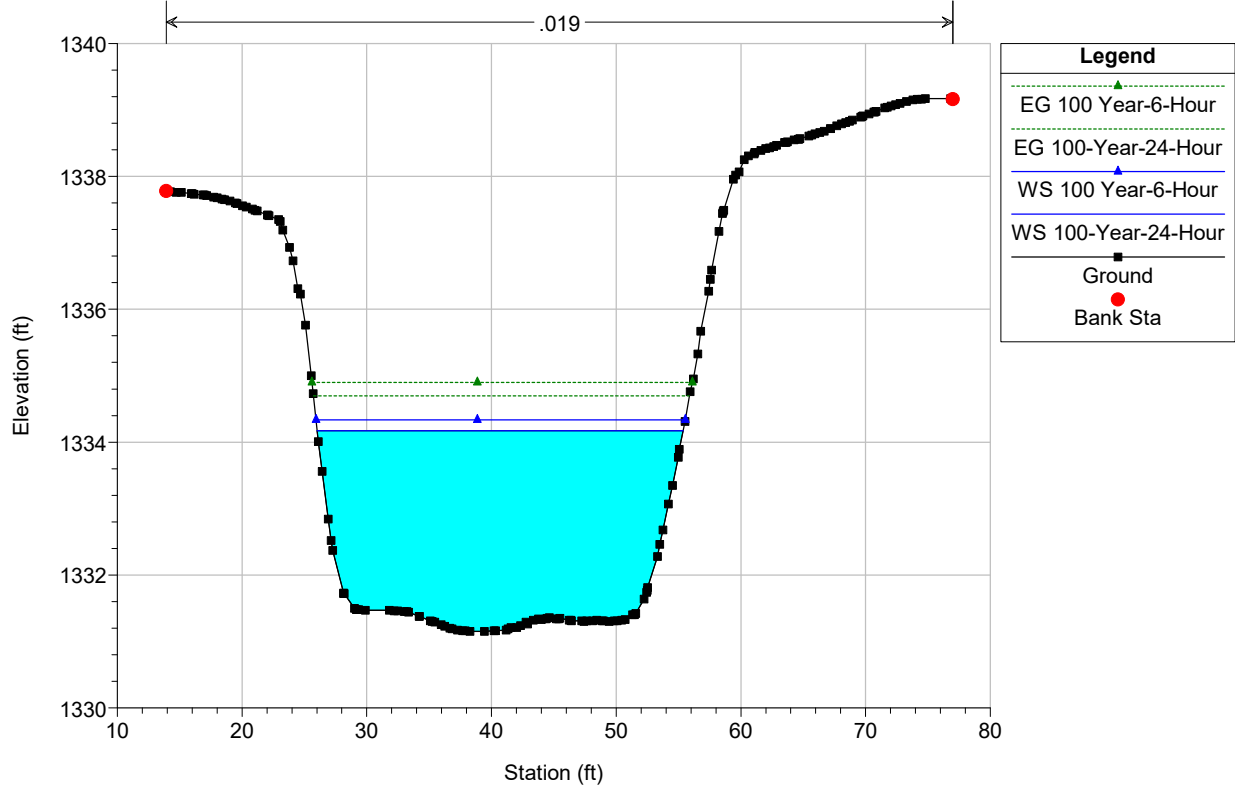


Gold Dust Aprt Plan: Gold Dust Aprt Pre-Project 2/2/2023
 River = Unnamed Wash Reach = Gold Dust Aprt. RS = 363



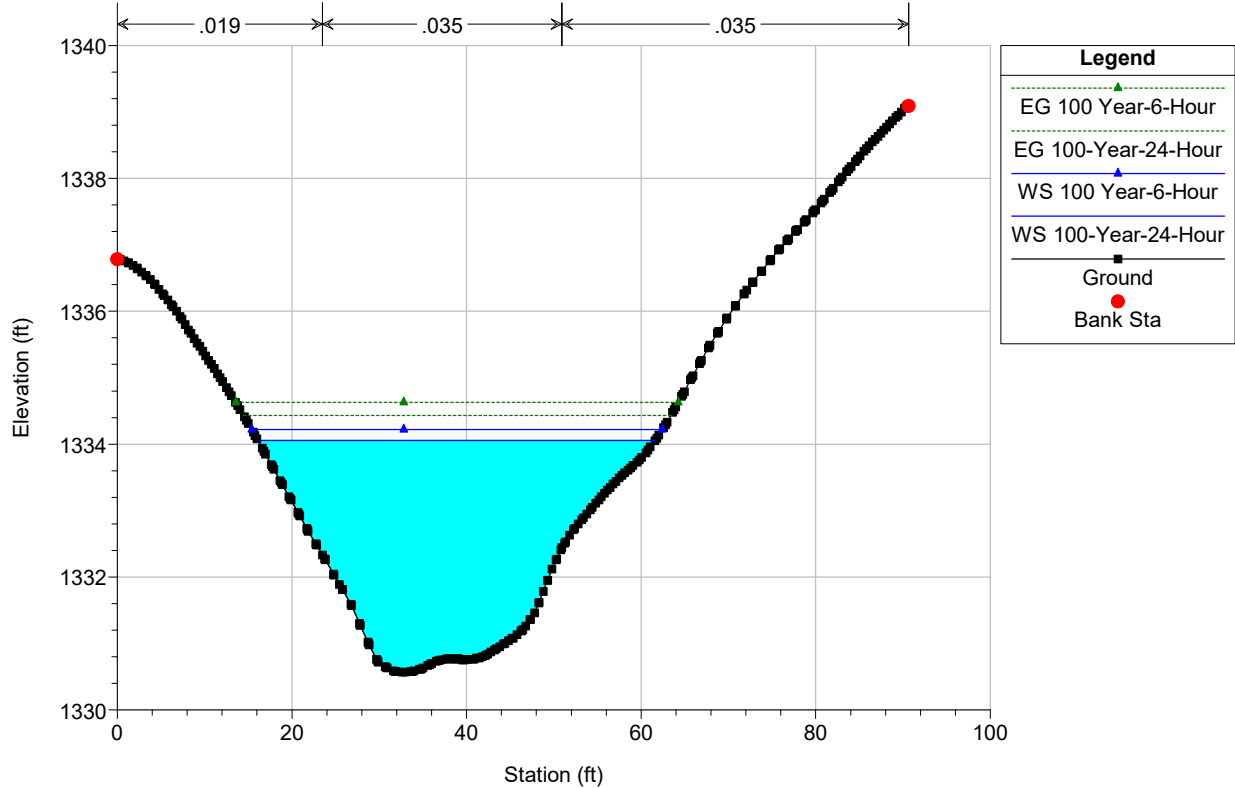


Gold Dust Aprt Plan: Gold Dust Aprt Pre-Project 2/2/2023
 River = Unnamed Wash Reach = Gold Dust Aprt. RS = 280



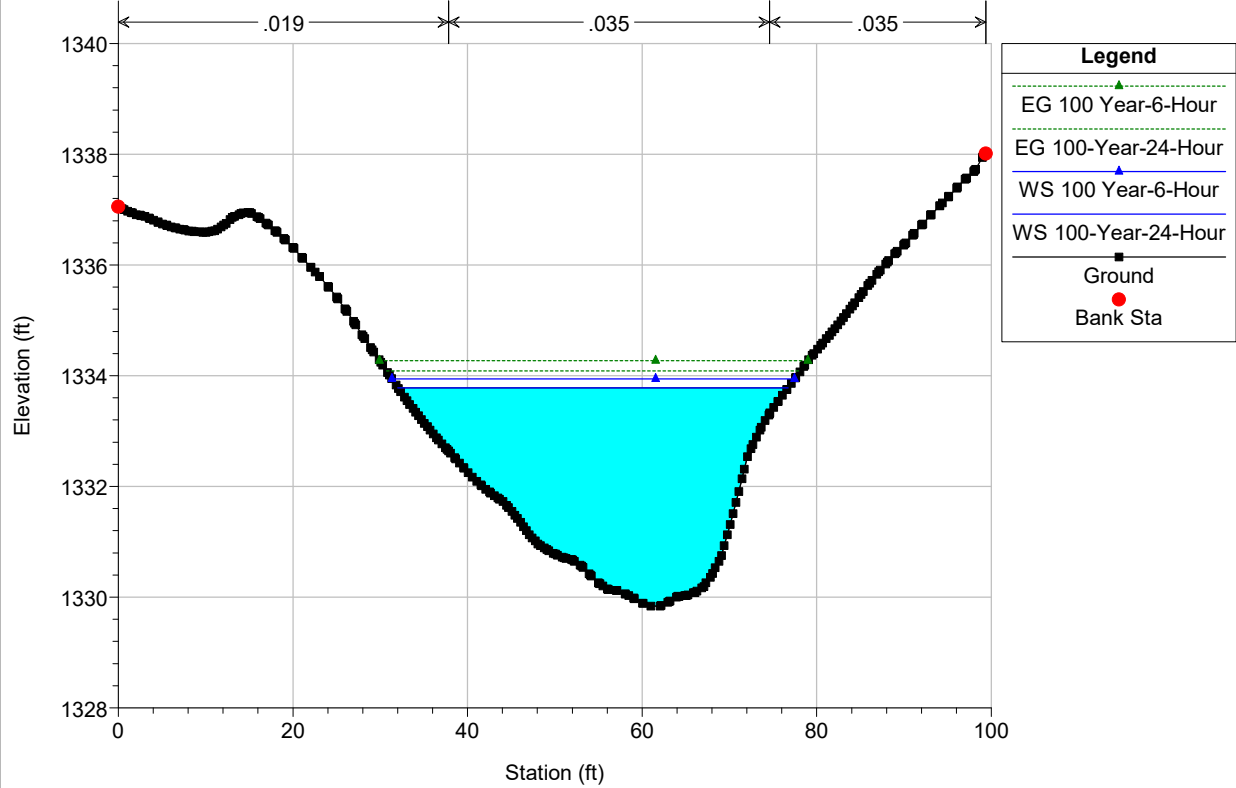
| Legend | |
|---------------------|--|
| EG 100 Year-6-Hour | |
| EG 100-Year-24-Hour | |
| WS 100 Year-6-Hour | |
| WS 100-Year-24-Hour | |
| Ground | |
| Bank Sta | |

Gold Dust Aprt Plan: Gold Dust Aprt Pre-Project 2/2/2023
 River = Unnamed Wash Reach = Gold Dust Aprt. RS = 202

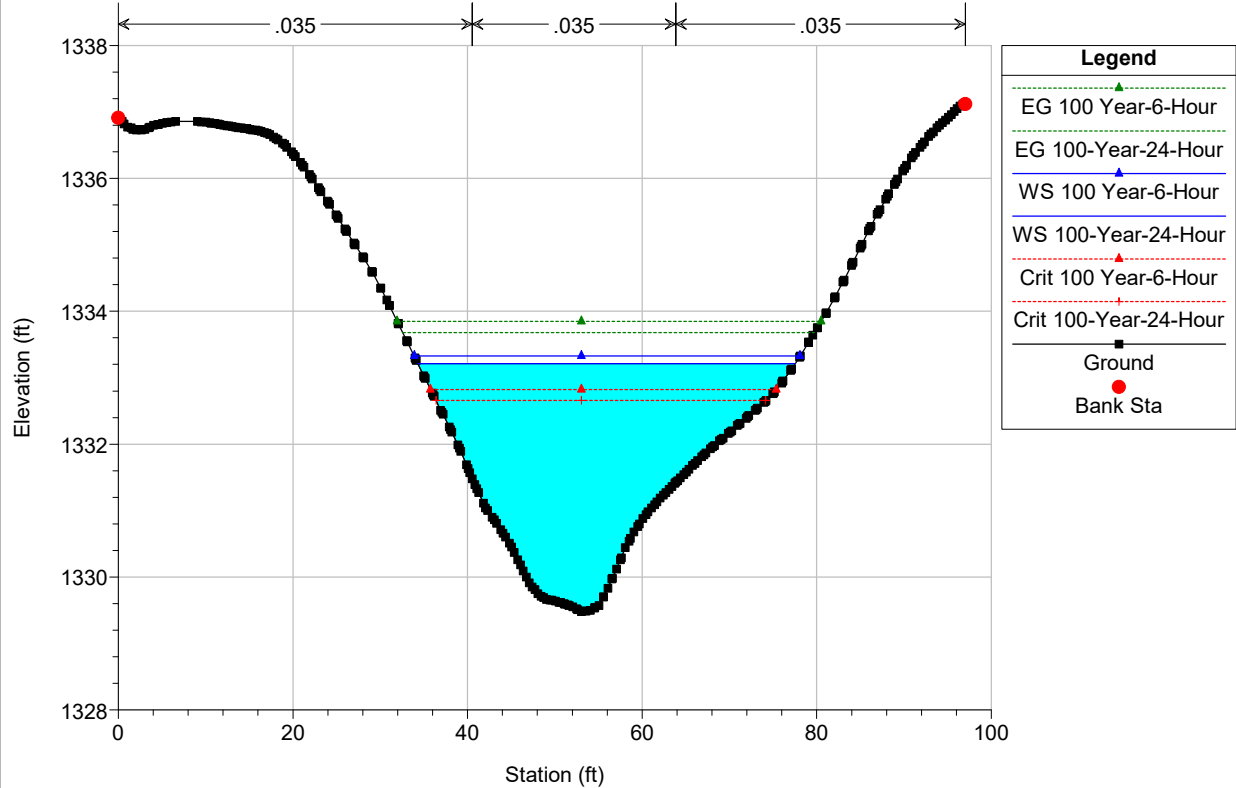


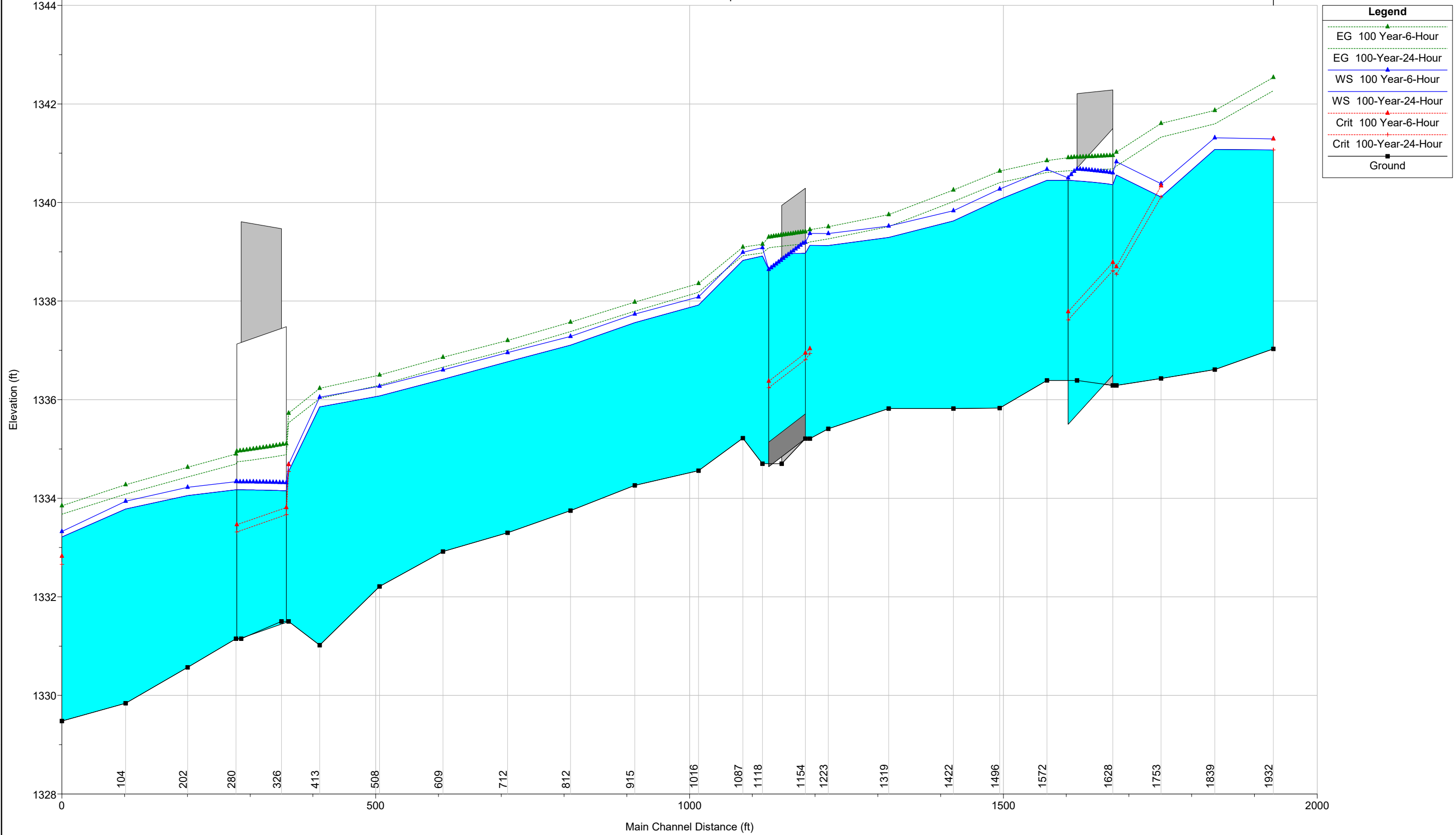
| Legend | |
|---------------------|--|
| EG 100 Year-6-Hour | |
| EG 100-Year-24-Hour | |
| WS 100 Year-6-Hour | |
| WS 100-Year-24-Hour | |
| Ground | |
| Bank Sta | |

Gold Dust Aprt Plan: Gold Dust Aprt Pre-Project 2/2/2023
 River = Unnamed Wash Reach = Gold Dust Aprt. RS = 104



Gold Dust Aprt Plan: Gold Dust Aprt Pre-Project 2/2/2023
 River = Unnamed Wash Reach = Gold Dust Aprt. RS = 2





HEC-RAS Plan: Gold Dust Aprt Pre-Project River: Unnamed Wash Reach: Gold Dust Aprt.

| Reach | River Sta | Profile | Q Total (cfs) | Min Ch El (ft) | W.S. Elev (ft) | Crit W.S. (ft) | E.G. Elev (ft) | E.G. Slope (ft/ft) | Vel Chnl (ft/s) | Flow Area (sq ft) | Top Width (ft) | Froude # Chl |
|-----------------|-----------|------------------|------------------|-------------------|-------------------|-------------------|-------------------|-----------------------|--------------------|----------------------|-------------------|--------------|
| Gold Dust Aprt. | 1932 | 100-Year-24-Hour | 420.00 | 1337.03 | 1341.07 | 1341.07 | 1342.27 | 0.004486 | 8.79 | 47.79 | 20.25 | 1.01 |
| Gold Dust Aprt. | 1932 | 100 Year-6-Hour | 470.00 | 1337.03 | 1341.29 | 1341.29 | 1342.54 | 0.004414 | 8.96 | 52.43 | 21.30 | 1.01 |
| Gold Dust Aprt. | 1839 | 100-Year-24-Hour | 420.00 | 1336.61 | 1341.08 | | 1341.60 | 0.001441 | 5.78 | 72.72 | 24.75 | 0.59 |
| Gold Dust Aprt. | 1839 | 100 Year-6-Hour | 470.00 | 1336.61 | 1341.31 | | 1341.87 | 0.001461 | 5.98 | 78.61 | 25.63 | 0.60 |
| Gold Dust Aprt. | 1753 | 100-Year-24-Hour | 420.00 | 1336.43 | 1340.11 | 1340.11 | 1341.33 | 0.004446 | 8.83 | 47.54 | 19.89 | 1.01 |
| Gold Dust Aprt. | 1753 | 100 Year-6-Hour | 470.00 | 1336.43 | 1340.38 | 1340.34 | 1341.60 | 0.004138 | 8.87 | 52.98 | 20.81 | 0.98 |
| Gold Dust Aprt. | 1682 | 100-Year-24-Hour | 420.00 | 1336.29 | 1340.56 | 1338.54 | 1340.74 | 0.000414 | 3.41 | 123.08 | 37.21 | 0.33 |
| Gold Dust Aprt. | 1682 | 100 Year-6-Hour | 470.00 | 1336.29 | 1340.83 | 1338.70 | 1341.02 | 0.000410 | 3.53 | 133.11 | 37.66 | 0.33 |
| Gold Dust Aprt. | 1628 | | Culvert | | | | | | | | | |
| Gold Dust Aprt. | 1572 | 100-Year-24-Hour | 420.00 | 1336.39 | 1340.45 | | 1340.61 | 0.001112 | 3.22 | 130.24 | 39.64 | 0.31 |
| Gold Dust Aprt. | 1572 | 100 Year-6-Hour | 470.00 | 1336.39 | 1340.67 | | 1340.85 | 0.001130 | 3.38 | 139.13 | 40.27 | 0.32 |
| Gold Dust Aprt. | 1496 | 100-Year-24-Hour | 460.00 | 1335.83 | 1340.06 | | 1340.41 | 0.004318 | 4.69 | 98.09 | 40.52 | 0.53 |
| Gold Dust Aprt. | 1496 | 100 Year-6-Hour | 518.00 | 1335.83 | 1340.27 | | 1340.64 | 0.004417 | 4.85 | 106.82 | 43.06 | 0.54 |
| Gold Dust Aprt. | 1422 | 100-Year-24-Hour | 460.00 | 1335.82 | 1339.63 | | 1340.02 | 0.006192 | 5.04 | 91.20 | 40.93 | 0.60 |
| Gold Dust Aprt. | 1422 | 100 Year-6-Hour | 518.00 | 1335.82 | 1339.83 | | 1340.25 | 0.006099 | 5.19 | 99.90 | 42.57 | 0.60 |
| Gold Dust Aprt. | 1319 | 100-Year-24-Hour | 460.00 | 1335.82 | 1339.29 | | 1339.51 | 0.003315 | 3.78 | 121.72 | 52.60 | 0.44 |
| Gold Dust Aprt. | 1319 | 100 Year-6-Hour | 518.00 | 1335.82 | 1339.52 | | 1339.75 | 0.003190 | 3.87 | 134.02 | 54.45 | 0.43 |
| Gold Dust Aprt. | 1223 | 100-Year-24-Hour | 460.00 | 1335.41 | 1339.13 | | 1339.26 | 0.001740 | 2.93 | 157.03 | 65.35 | 0.33 |
| Gold Dust Aprt. | 1223 | 100 Year-6-Hour | 518.00 | 1335.41 | 1339.37 | | 1339.51 | 0.001666 | 3.00 | 172.95 | 66.26 | 0.33 |
| Gold Dust Aprt. | 1193 | 100-Year-24-Hour | 460.00 | 1335.21 | 1339.13 | 1336.94 | 1339.20 | 0.000605 | 2.10 | 218.78 | 70.27 | 0.21 |
| Gold Dust Aprt. | 1193 | 100 Year-6-Hour | 518.00 | 1335.21 | 1339.37 | 1337.03 | 1339.45 | 0.000598 | 2.20 | 235.62 | 70.48 | 0.21 |
| Gold Dust Aprt. | 1154 | | Culvert | | | | | | | | | |
| Gold Dust Aprt. | 1118 | 100-Year-24-Hour | 460.00 | 1334.70 | 1338.92 | | 1338.98 | 0.000436 | 1.98 | 232.89 | 80.40 | 0.20 |
| Gold Dust Aprt. | 1118 | 100 Year-6-Hour | 518.00 | 1334.70 | 1339.09 | | 1339.15 | 0.000460 | 2.10 | 246.73 | 81.52 | 0.21 |
| Gold Dust Aprt. | 1087 | 100-Year-24-Hour | 460.00 | 1335.22 | 1338.83 | | 1338.92 | 0.059473 | 2.45 | 187.61 | 68.45 | 0.26 |
| Gold Dust Aprt. | 1087 | 100 Year-6-Hour | 518.00 | 1335.22 | 1338.99 | | 1339.09 | 0.062155 | 2.60 | 198.88 | 69.91 | 0.27 |
| Gold Dust Aprt. | 1016 | 100-Year-24-Hour | 440.00 | 1334.56 | 1337.92 | | 1338.18 | 0.003942 | 4.10 | 107.43 | 51.38 | 0.50 |
| Gold Dust Aprt. | 1016 | 100 Year-6-Hour | 485.00 | 1334.56 | 1338.08 | | 1338.35 | 0.003834 | 4.18 | 115.95 | 52.85 | 0.50 |
| Gold Dust Aprt. | 915 | 100-Year-24-Hour | 440.00 | 1334.26 | 1337.56 | | 1337.79 | 0.003515 | 3.86 | 113.86 | 50.15 | 0.45 |
| Gold Dust Aprt. | 915 | 100 Year-6-Hour | 485.00 | 1334.26 | 1337.73 | | 1337.98 | 0.003448 | 3.96 | 122.63 | 51.46 | 0.45 |
| Gold Dust Aprt. | 812 | 100-Year-24-Hour | 440.00 | 1333.75 | 1337.11 | | 1337.38 | 0.004566 | 4.21 | 104.58 | 44.83 | 0.49 |
| Gold Dust Aprt. | 812 | 100 Year-6-Hour | 485.00 | 1333.75 | 1337.28 | | 1337.57 | 0.004487 | 4.31 | 112.64 | 45.83 | 0.48 |
| Gold Dust Aprt. | 712 | 100-Year-24-Hour | 440.00 | 1333.30 | 1336.77 | | 1337.00 | 0.002967 | 3.89 | 112.97 | 47.48 | 0.45 |
| Gold Dust Aprt. | 712 | 100 Year-6-Hour | 485.00 | 1333.30 | 1336.96 | | 1337.20 | 0.002917 | 3.98 | 121.93 | 48.81 | 0.44 |
| Gold Dust Aprt. | 609 | 100-Year-24-Hour | 440.00 | 1332.92 | 1336.41 | | 1336.66 | 0.003776 | 3.98 | 110.68 | 44.60 | 0.44 |
| Gold Dust Aprt. | 609 | 100 Year-6-Hour | 485.00 | 1332.92 | 1336.60 | | 1336.86 | 0.003739 | 4.07 | 119.24 | 45.89 | 0.44 |
| Gold Dust Aprt. | 508 | 100-Year-24-Hour | 440.00 | 1332.21 | 1336.08 | | 1336.29 | 0.003331 | 3.73 | 117.99 | 47.18 | 0.42 |
| Gold Dust Aprt. | 508 | 100 Year-6-Hour | 485.00 | 1332.21 | 1336.27 | | 1336.50 | 0.003263 | 3.81 | 127.37 | 48.44 | 0.41 |
| Gold Dust Aprt. | 413 | 100-Year-24-Hour | 440.00 | 1331.02 | 1335.85 | | 1336.02 | 0.002207 | 3.31 | 133.11 | 46.67 | 0.35 |
| Gold Dust Aprt. | 413 | 100 Year-6-Hour | 485.00 | 1331.02 | 1336.05 | | 1336.23 | 0.002224 | 3.41 | 142.40 | 47.82 | 0.35 |
| Gold Dust Aprt. | 363 | 100-Year-24-Hour | 440.00 | 1331.50 | 1334.54 | 1334.54 | 1335.53 | 0.020865 | 7.97 | 55.23 | 28.69 | 1.01 |
| Gold Dust Aprt. | 363 | 100 Year-6-Hour | 485.00 | 1331.50 | 1334.69 | 1334.69 | 1335.72 | 0.020577 | 8.18 | 59.32 | 29.18 | 1.01 |
| Gold Dust Aprt. | 326 | | Culvert | | | | | | | | | |
| Gold Dust Aprt. | 280 | 100-Year-24-Hour | 440.00 | 1331.15 | 1334.17 | | 1334.70 | 0.001704 | 5.80 | 75.90 | 29.35 | 0.64 |
| Gold Dust Aprt. | 280 | 100 Year-6-Hour | 485.00 | 1331.15 | 1334.34 | | 1334.90 | 0.001718 | 6.01 | 80.70 | 29.62 | 0.64 |
| Gold Dust Aprt. | 202 | 100-Year-24-Hour | 470.00 | 1330.57 | 1334.05 | | 1334.43 | 0.003746 | 4.94 | 95.12 | 45.49 | 0.60 |
| Gold Dust Aprt. | 202 | 100 Year-6-Hour | 526.00 | 1330.57 | 1334.22 | | 1334.63 | 0.003769 | 5.12 | 102.82 | 47.04 | 0.61 |
| Gold Dust Aprt. | 104 | 100-Year-24-Hour | 470.00 | 1329.84 | 1333.78 | | 1334.08 | 0.002946 | 4.42 | 106.32 | 44.71 | 0.51 |
| Gold Dust Aprt. | 104 | 100 Year-6-Hour | 526.00 | 1329.84 | 1333.94 | | 1334.27 | 0.003020 | 4.63 | 113.58 | 46.12 | 0.52 |
| Gold Dust Aprt. | 2 | 100-Year-24-Hour | 470.00 | 1329.48 | 1333.21 | 1332.66 | 1333.68 | 0.005215 | 5.47 | 85.96 | 43.24 | 0.68 |
| Gold Dust Aprt. | 2 | 100 Year-6-Hour | 526.00 | 1329.48 | 1333.33 | 1332.82 | 1333.85 | 0.005621 | 5.79 | 90.86 | 44.19 | 0.71 |



| Legend | |
|--|--------------------------------|
| ● | BANK STATION |
| --- | RIVER REACH |
| | ROADWAY CROSSING |
| | CROSS SECTION W/ RIVER STATION |
| | 100 YR INUNDATION |

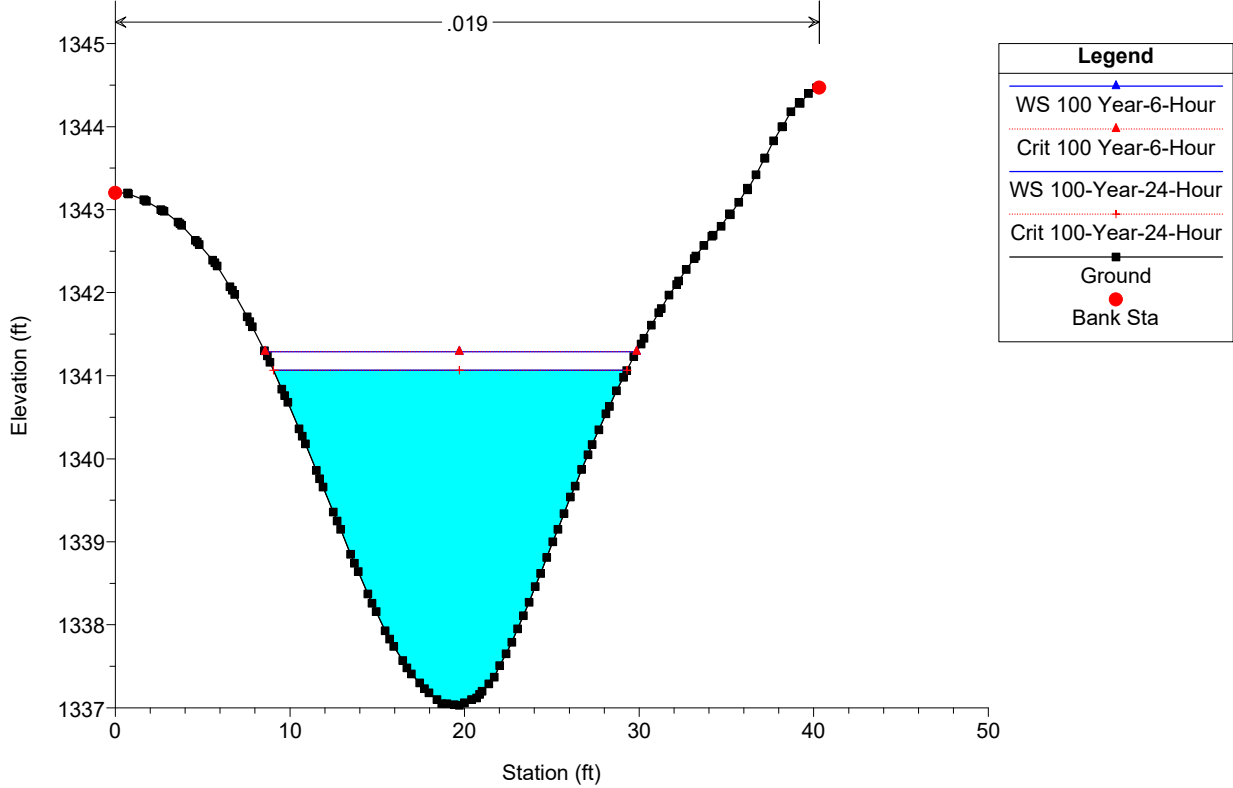
GOLD DUST APARTMENTS - UNNAMED CHANNEL

**Exhibit G-2
Post Project Condition 100 Year Inundation**

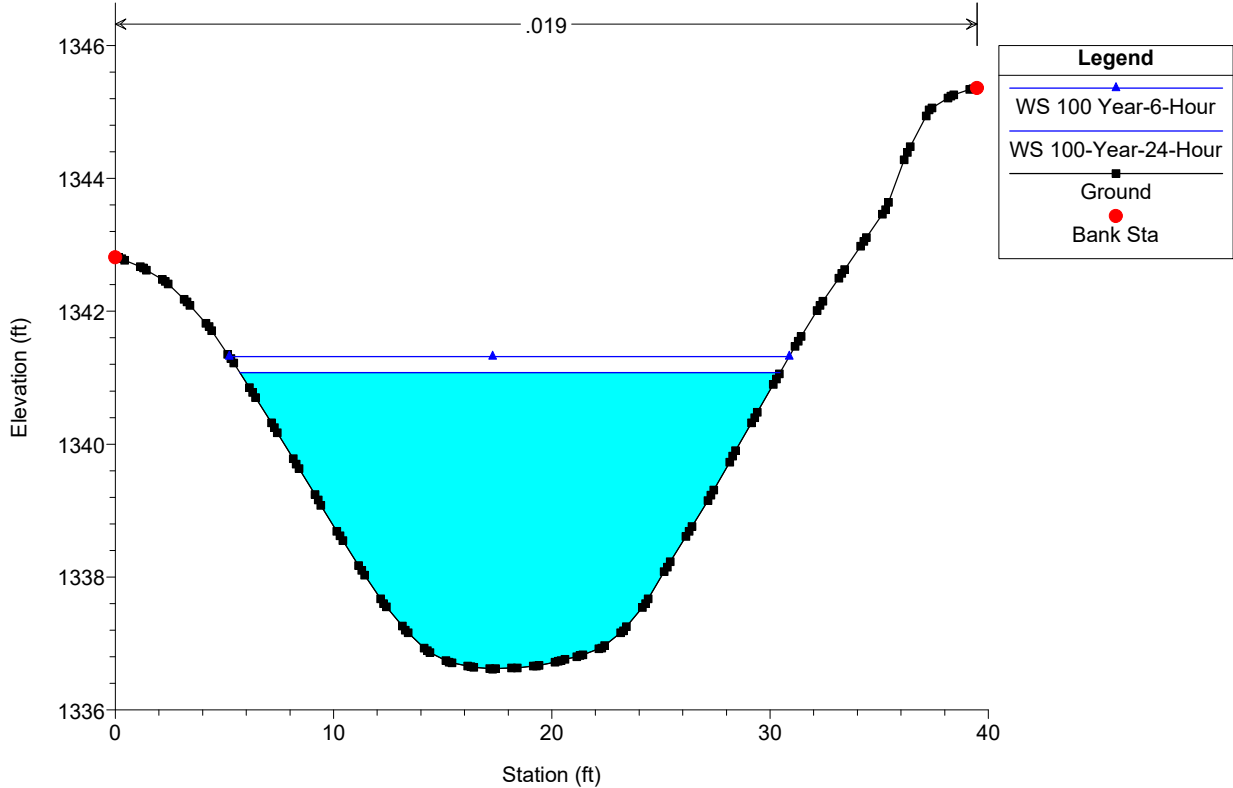


Exhibit G-1: Post Project Condition 100 Year Inundation

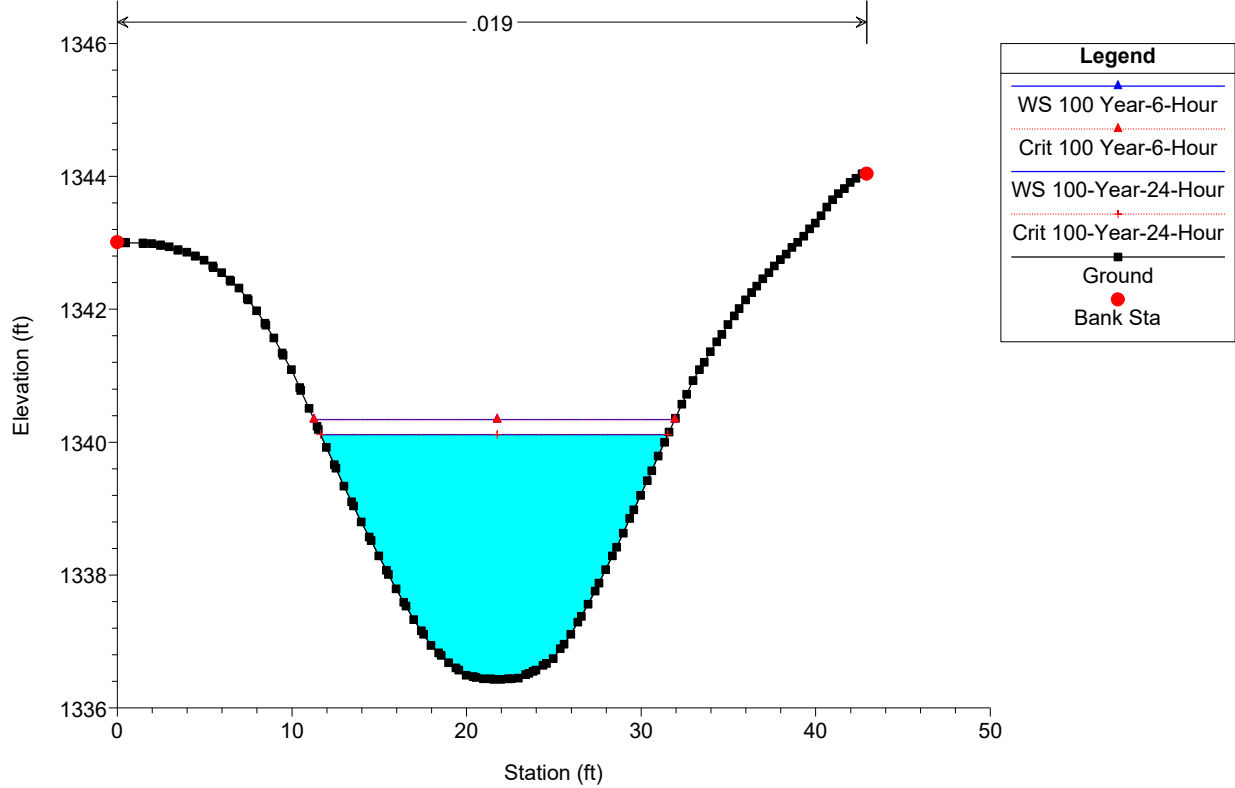
Gold Dust Aprt Plan: Gold Dust Aprt Pre-Project 9/1/2022
RS = 1932



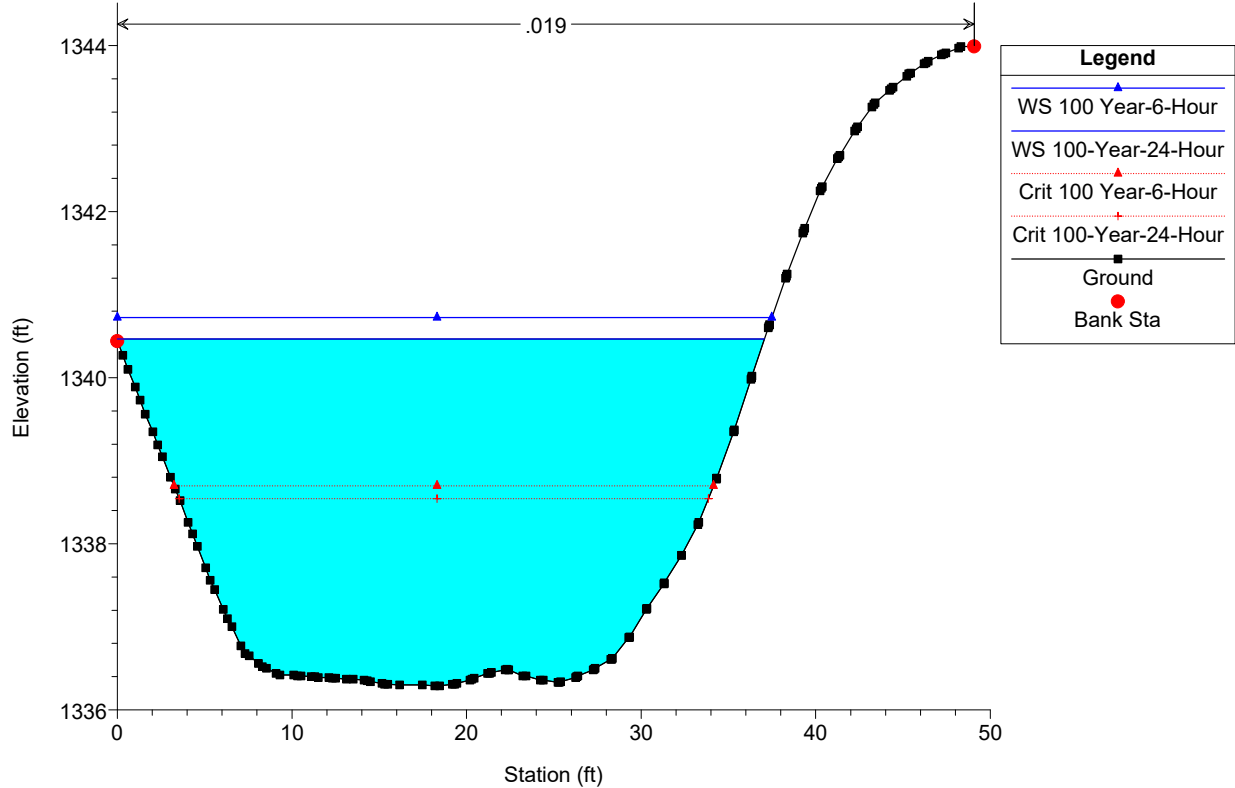
Gold Dust Aprt Plan: Gold Dust Aprt Pre-Project 9/1/2022
RS = 1839



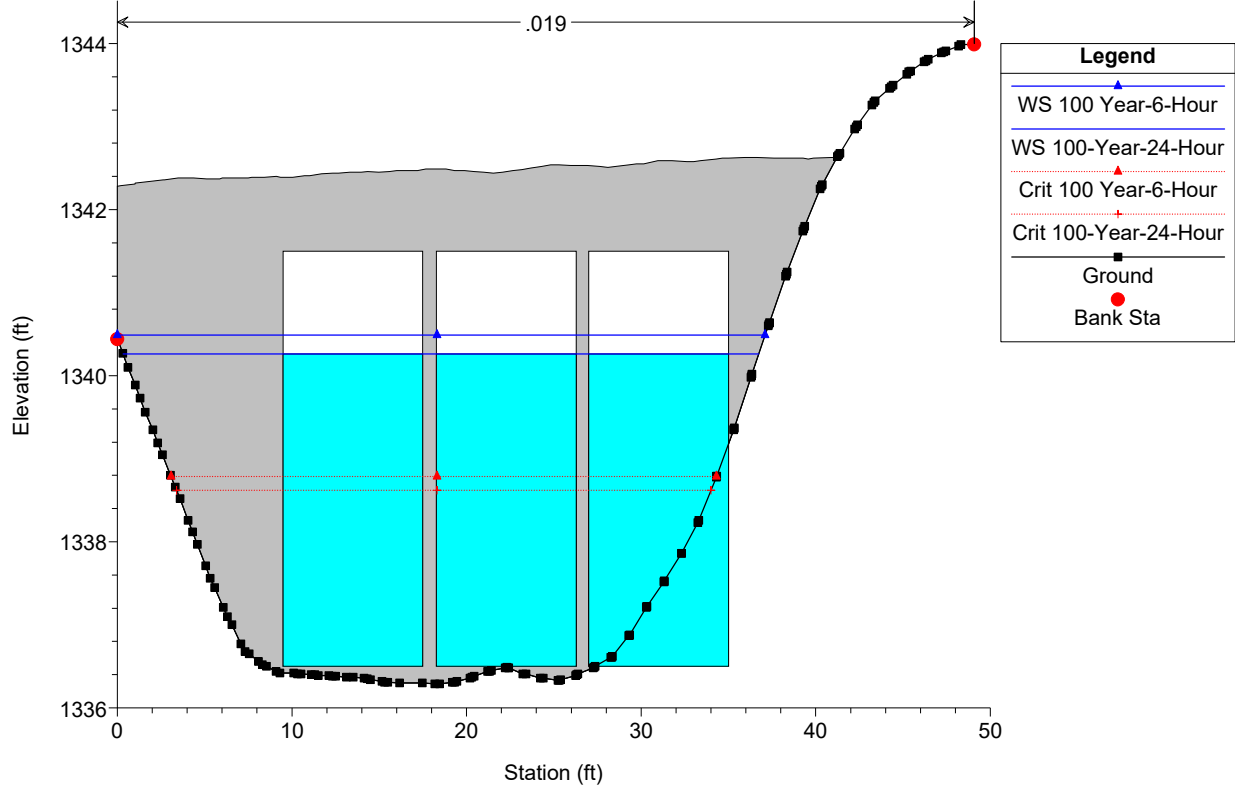
Gold Dust Aprt Plan: Gold Dust Aprt Pre-Project 9/1/2022
RS = 1753



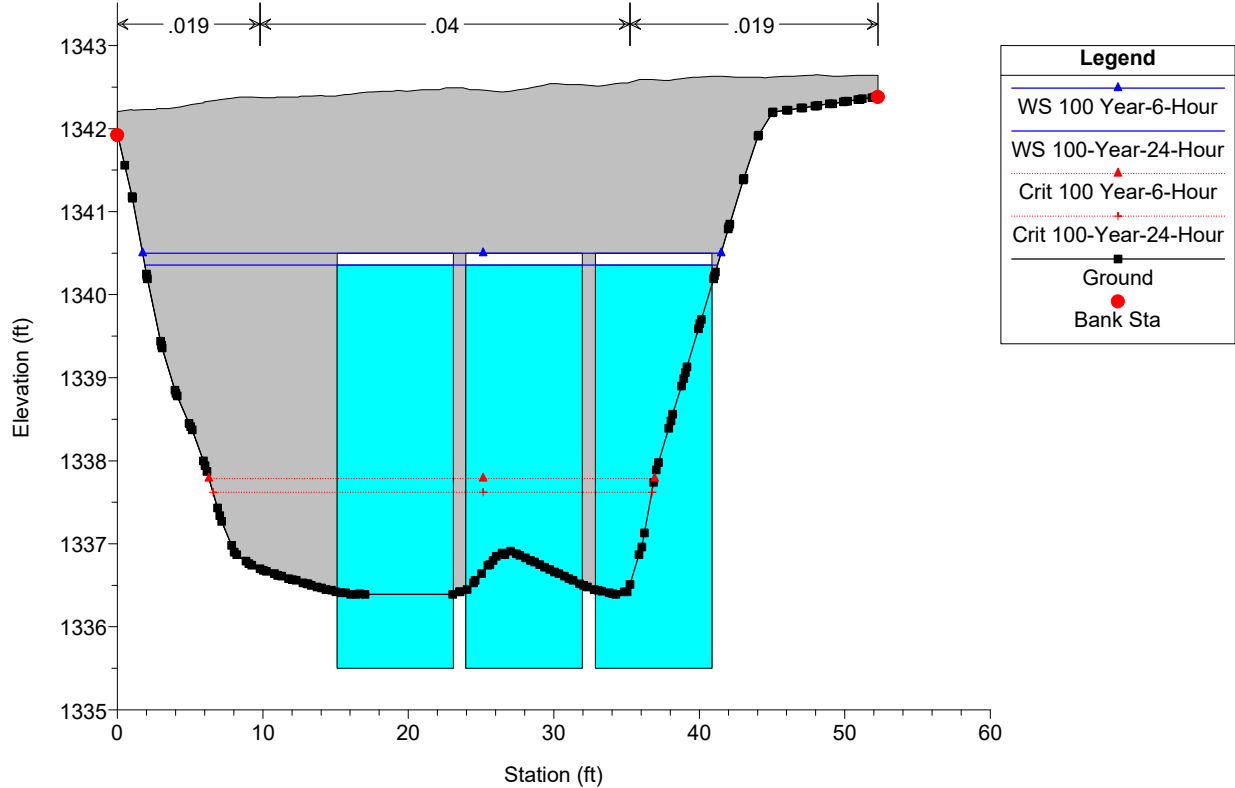
Gold Dust Aprt Plan: Gold Dust Aprt Pre-Project 9/1/2022
RS = 1682



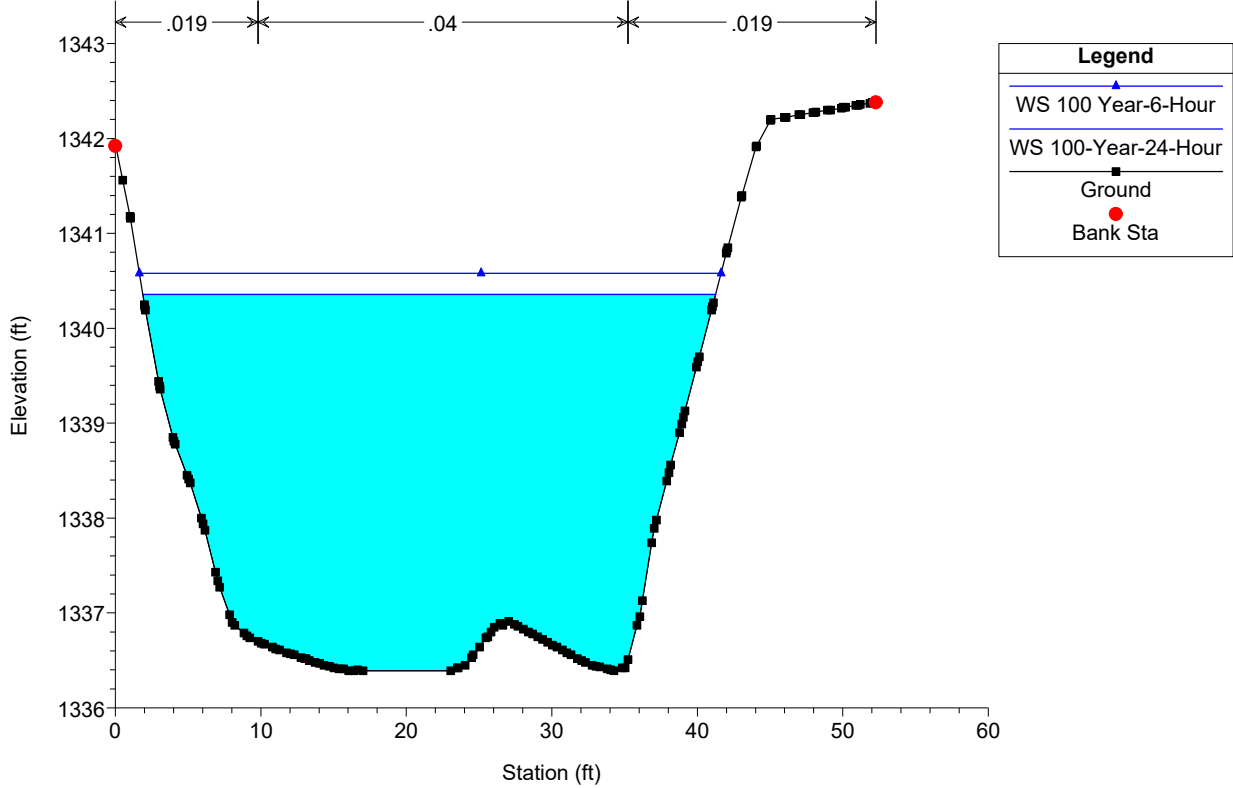
Gold Dust Aprt Plan: Gold Dust Aprt Pre-Project 9/1/2022
 RS = 1628 Culv Gold Dust Avenue



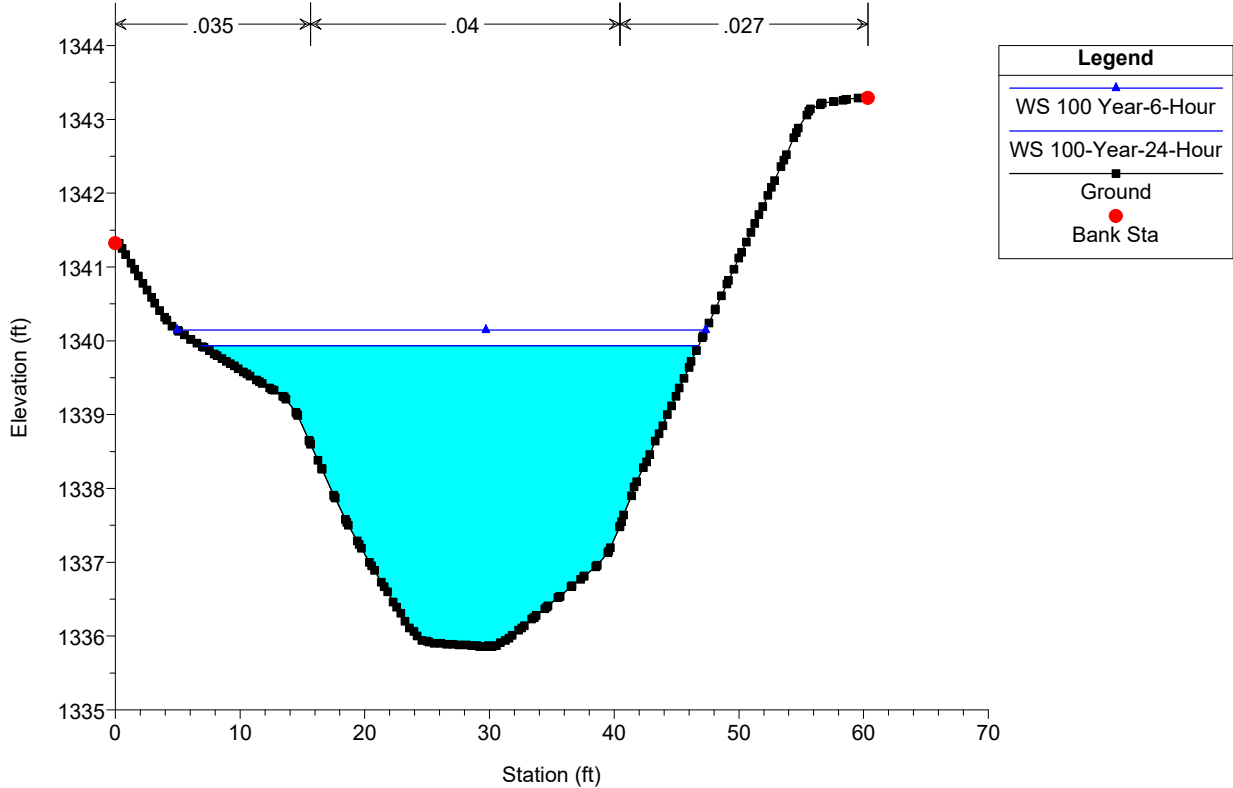
Gold Dust Aprt Plan: Gold Dust Aprt Pre-Project 9/1/2022
 RS = 1628 Culv Gold Dust Avenue

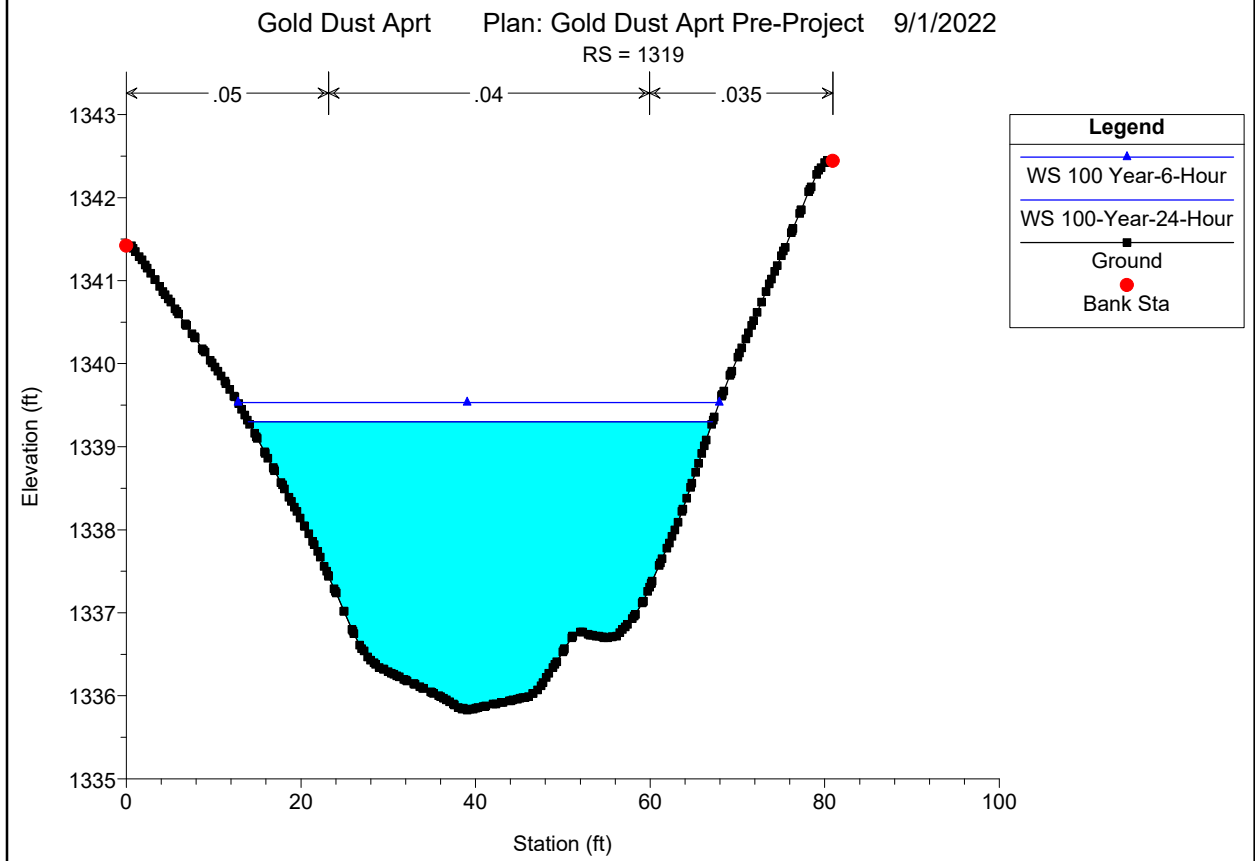
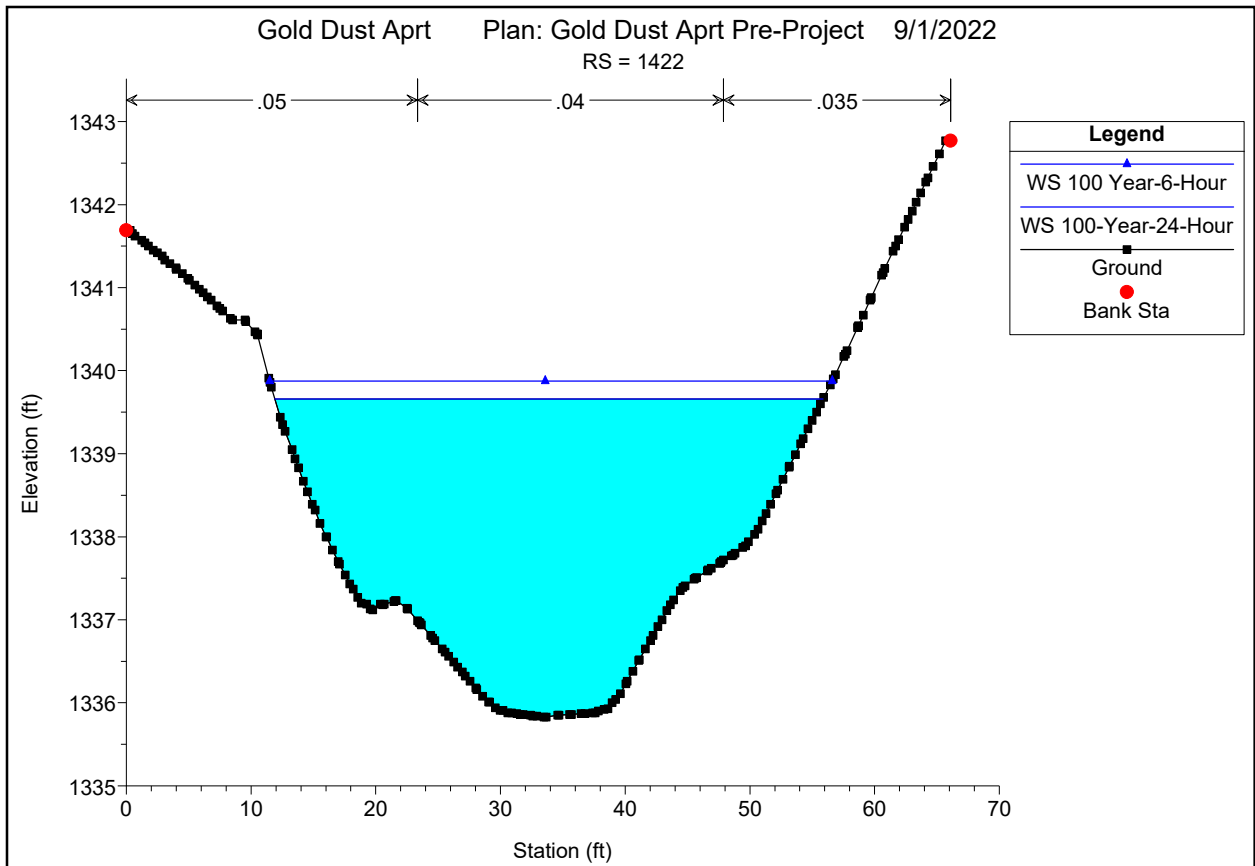


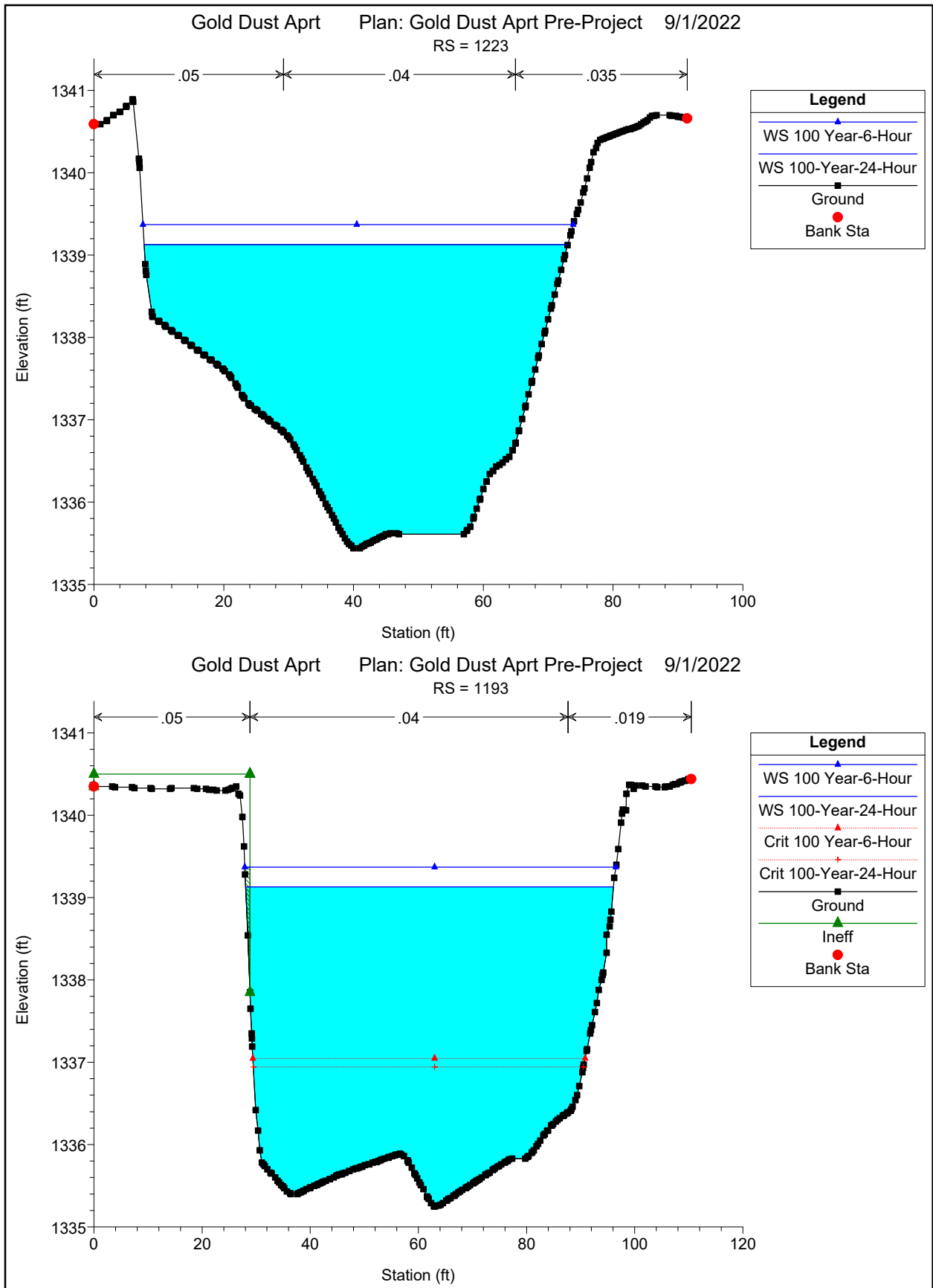
Gold Dust Aprt Plan: Gold Dust Aprt Pre-Project 9/1/2022
RS = 1572



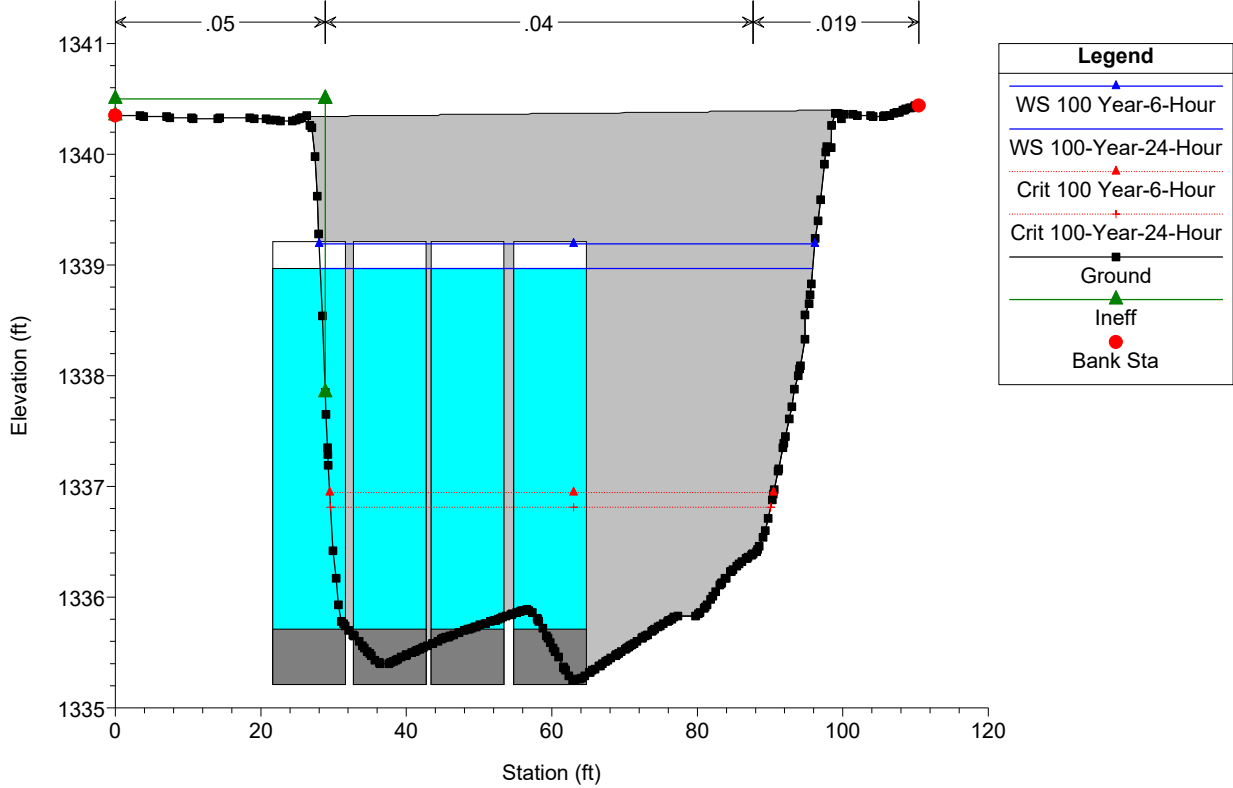
Gold Dust Aprt Plan: Gold Dust Aprt Pre-Project 9/1/2022
RS = 1496



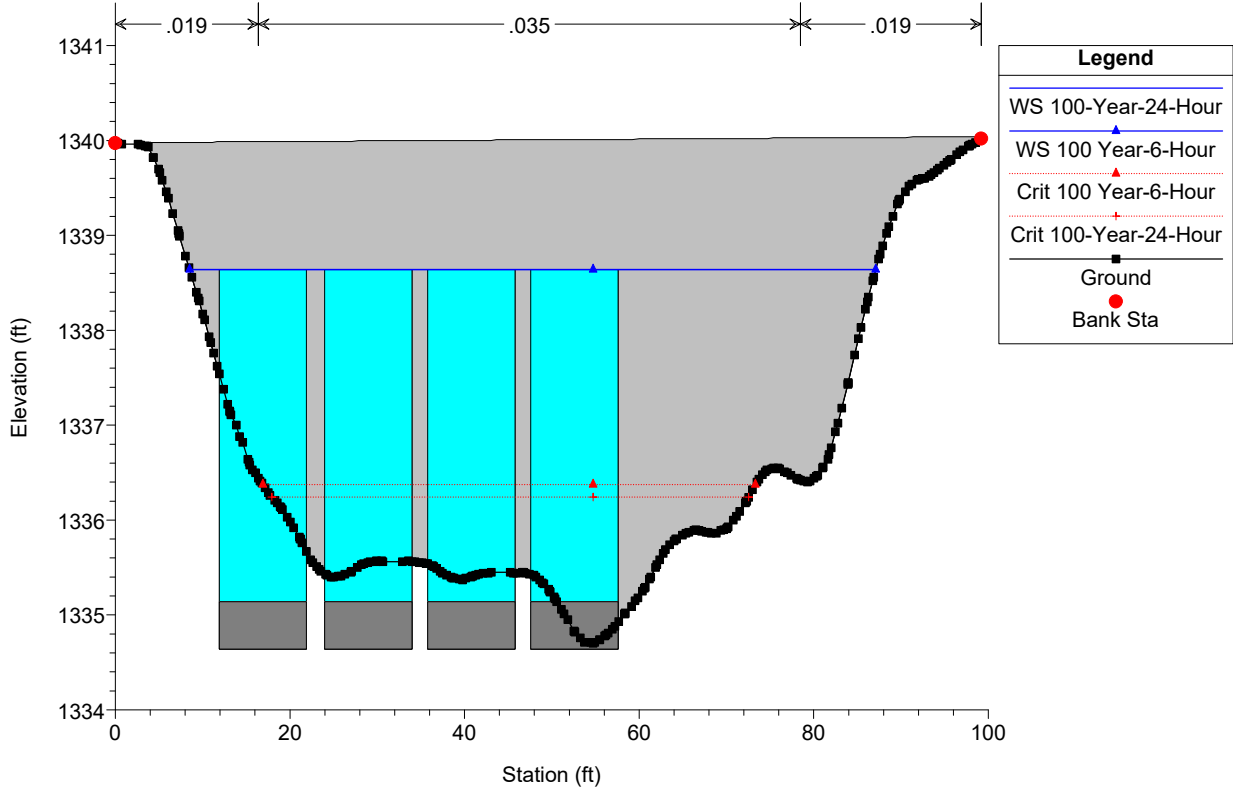


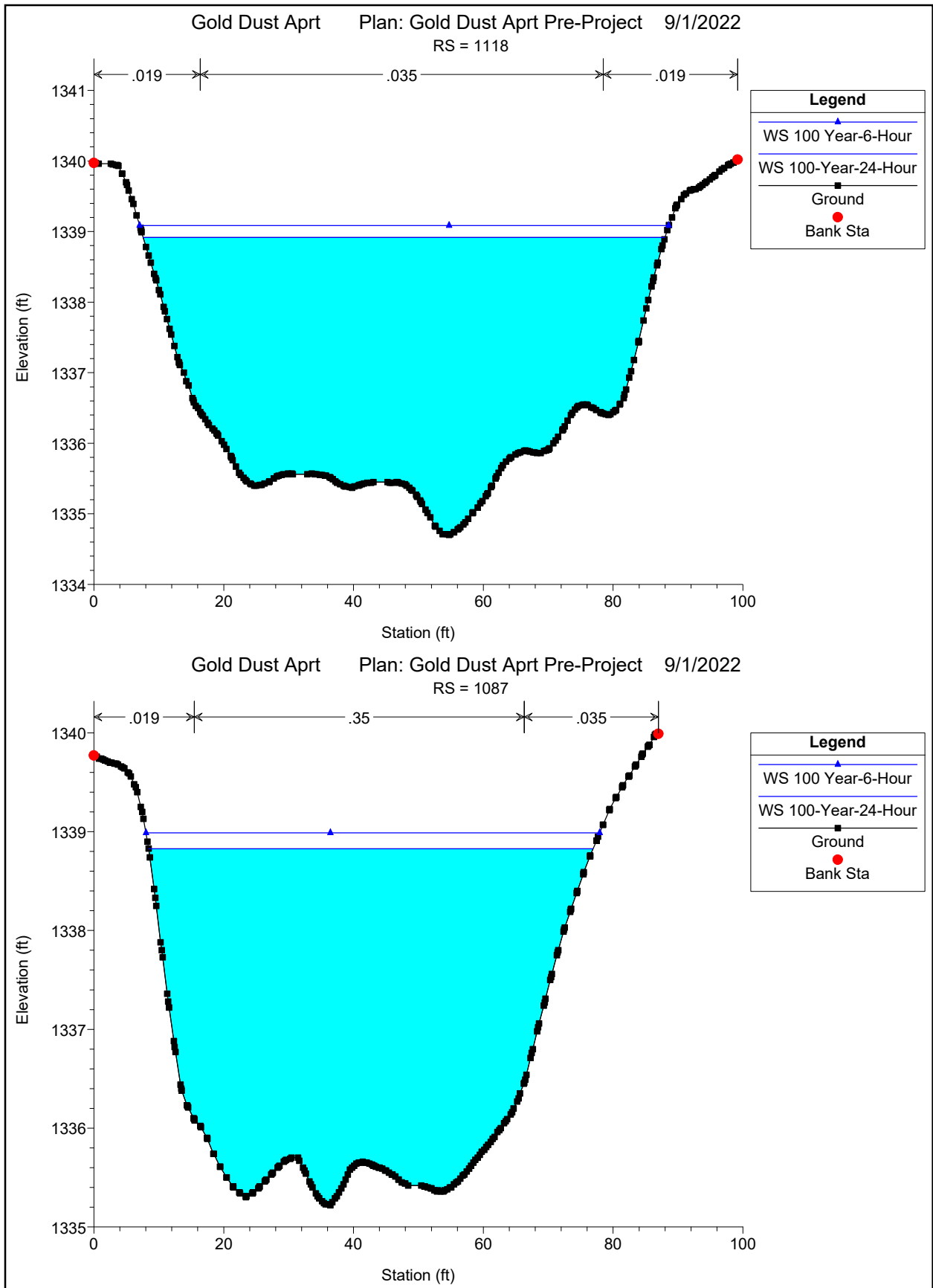


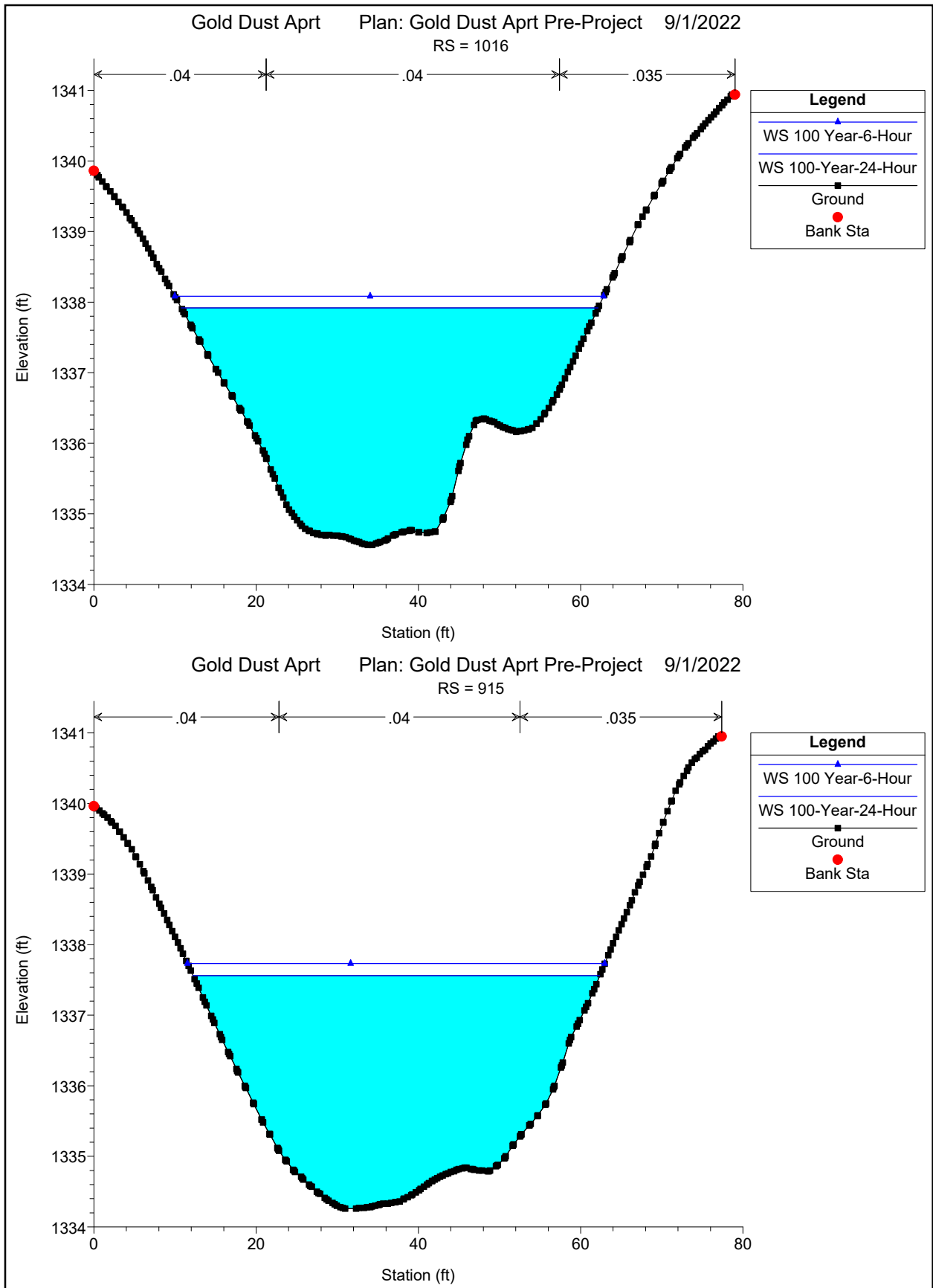
Gold Dust Aprt Plan: Gold Dust Aprt Pre-Project 9/1/2022
 RS = 1154 Culv Private Driveway



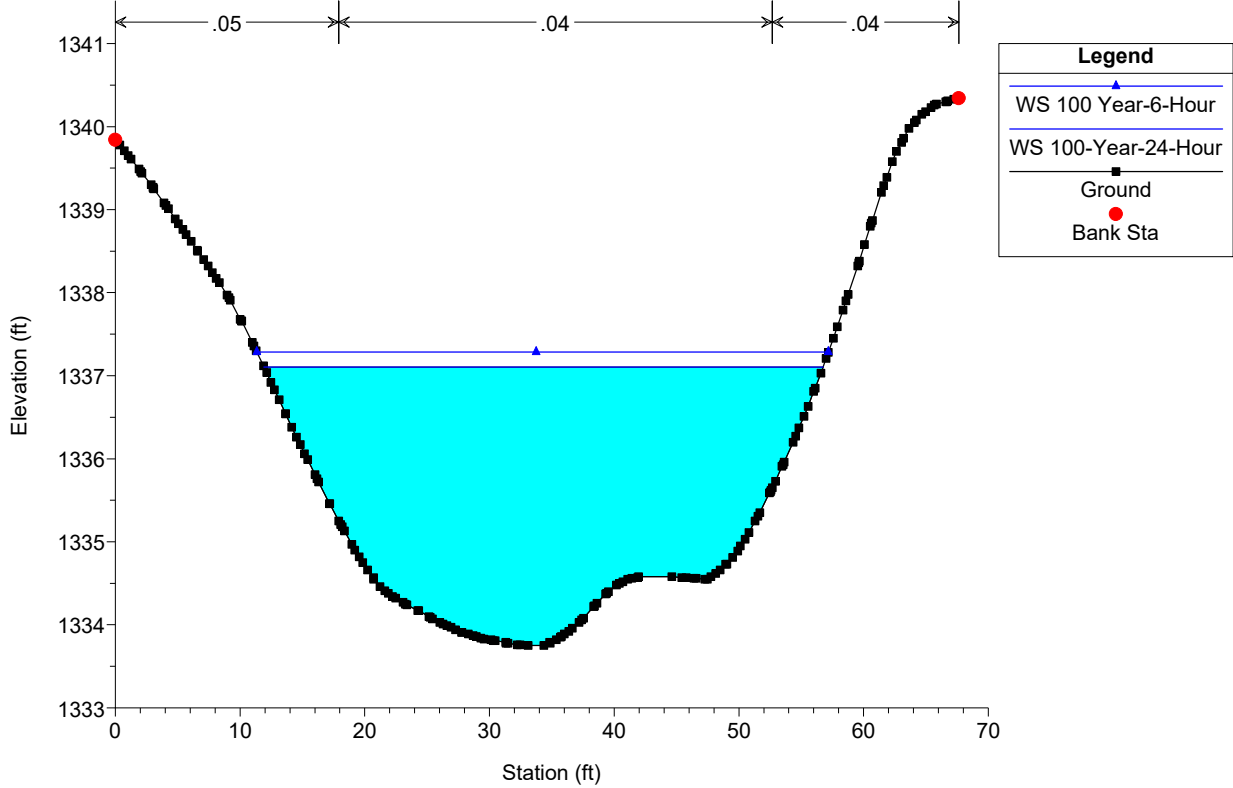
Gold Dust Aprt Plan: Gold Dust Aprt Pre-Project 9/1/2022
 RS = 1154 Culv Private Driveway



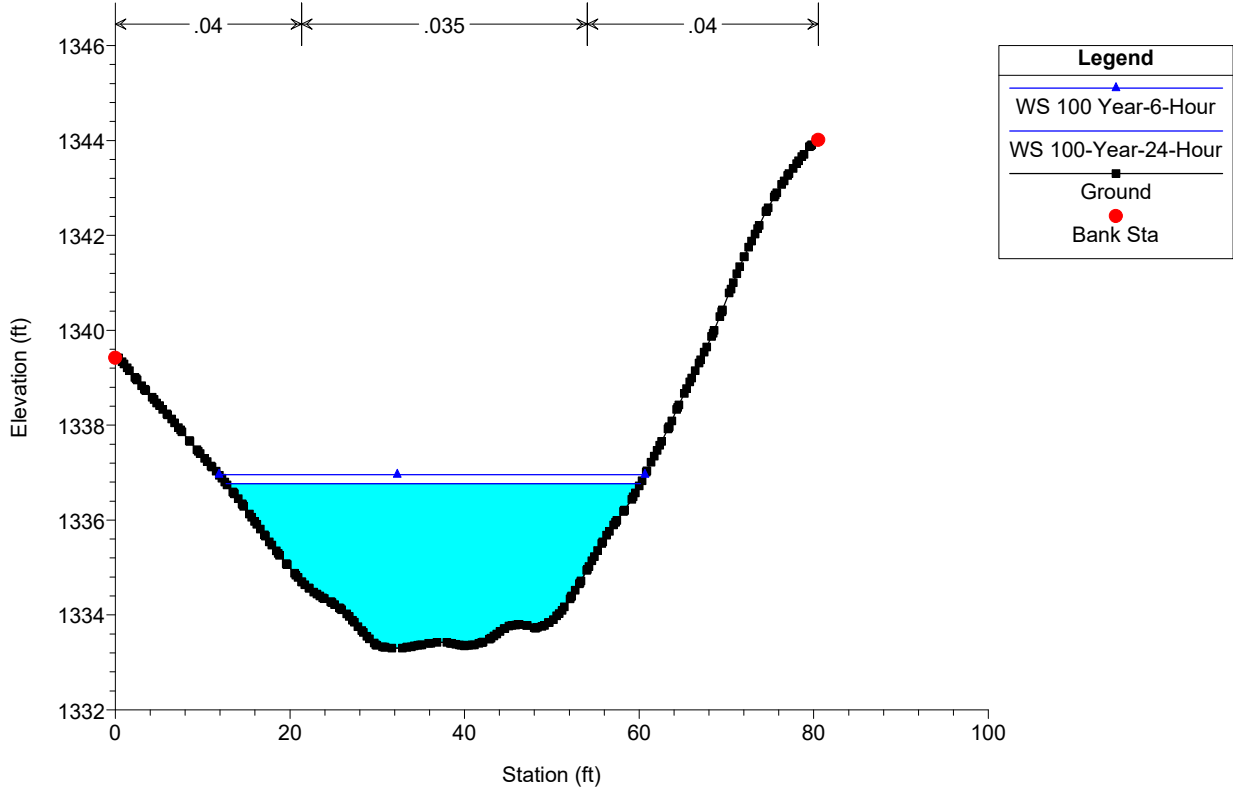


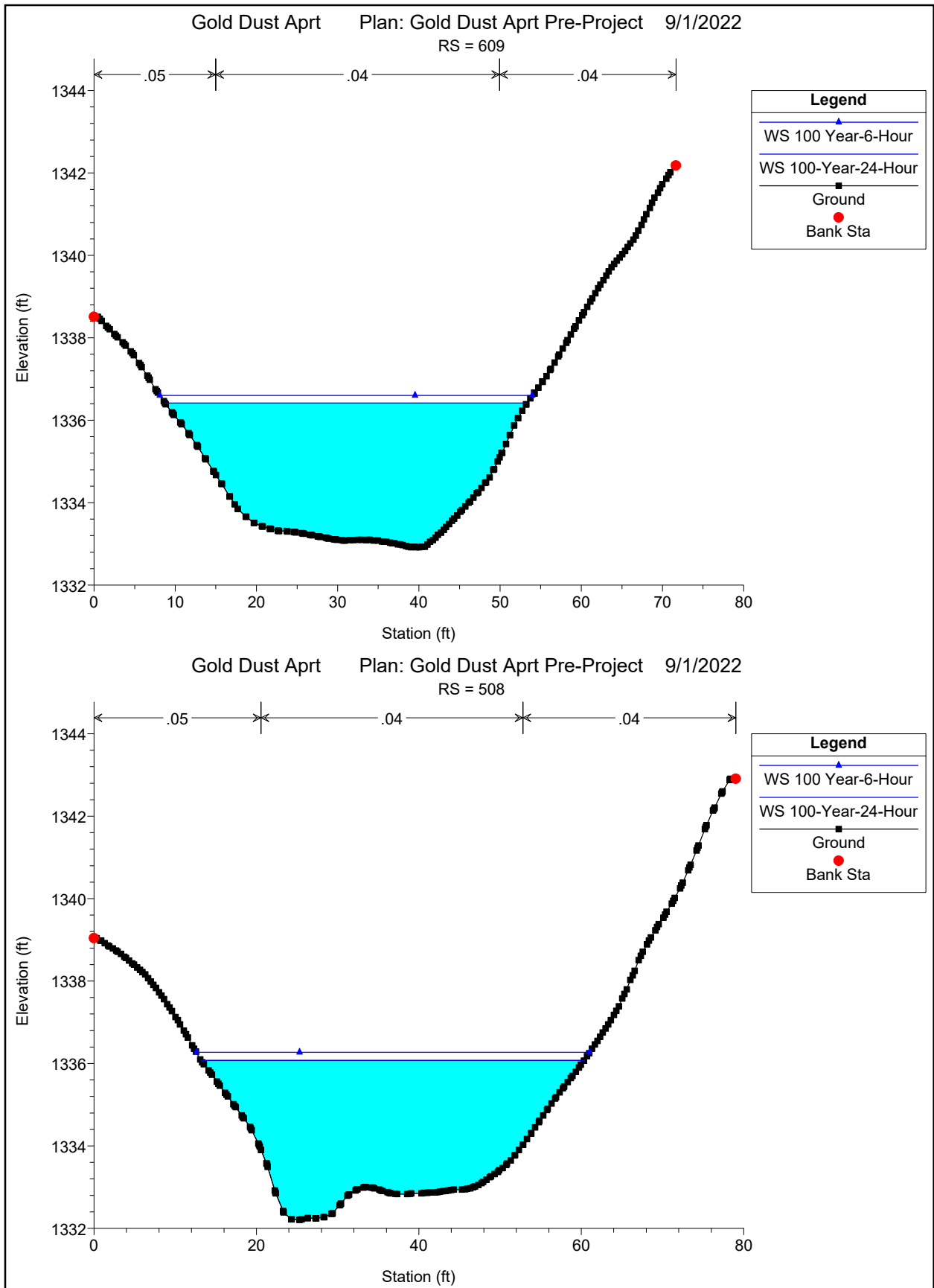


Gold Dust Aprt Plan: Gold Dust Aprt Pre-Project 9/1/2022
RS = 812

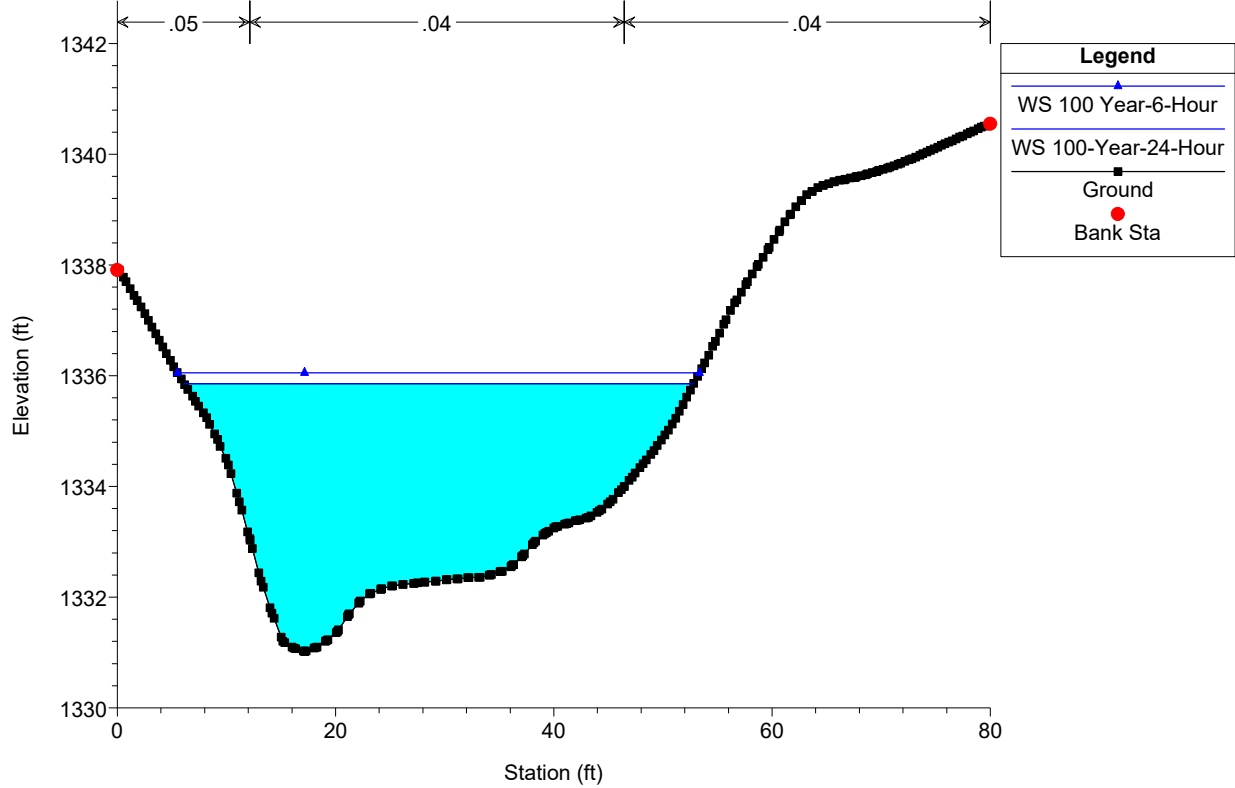


Gold Dust Aprt Plan: Gold Dust Aprt Pre-Project 9/1/2022
RS = 712

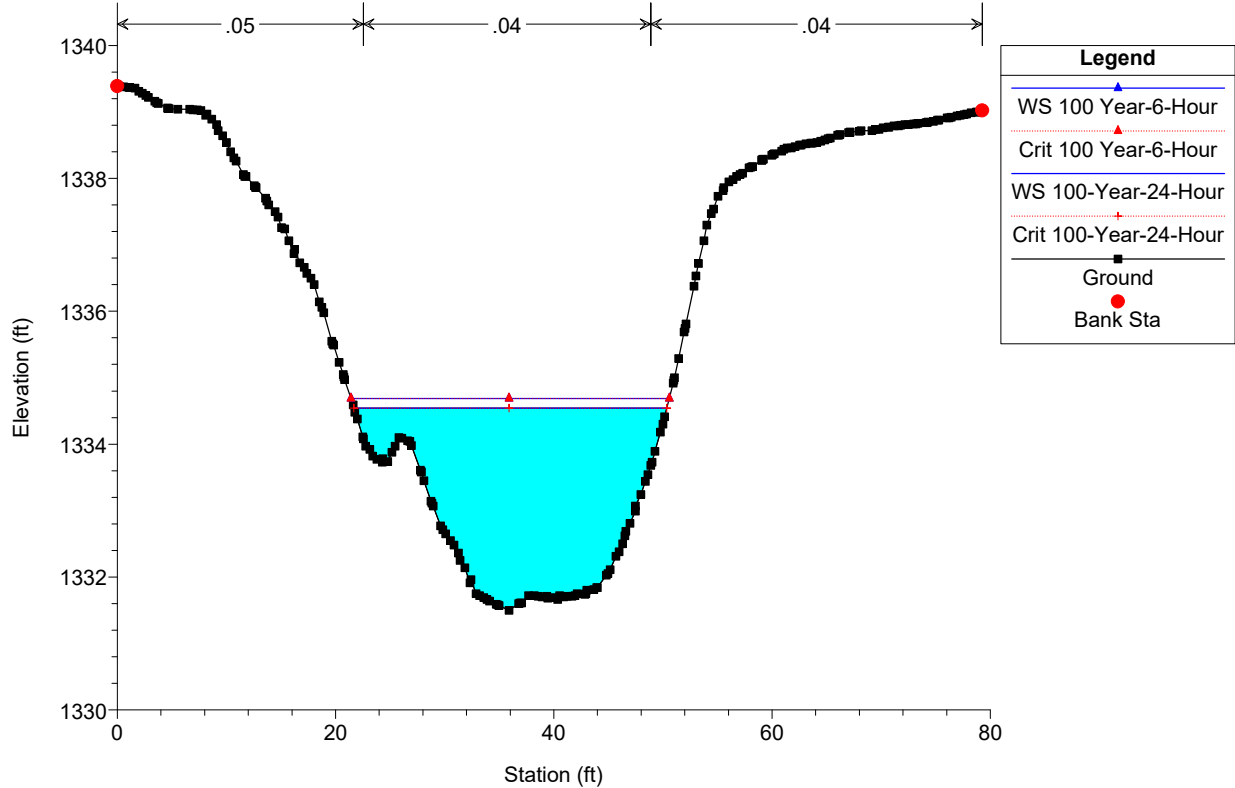




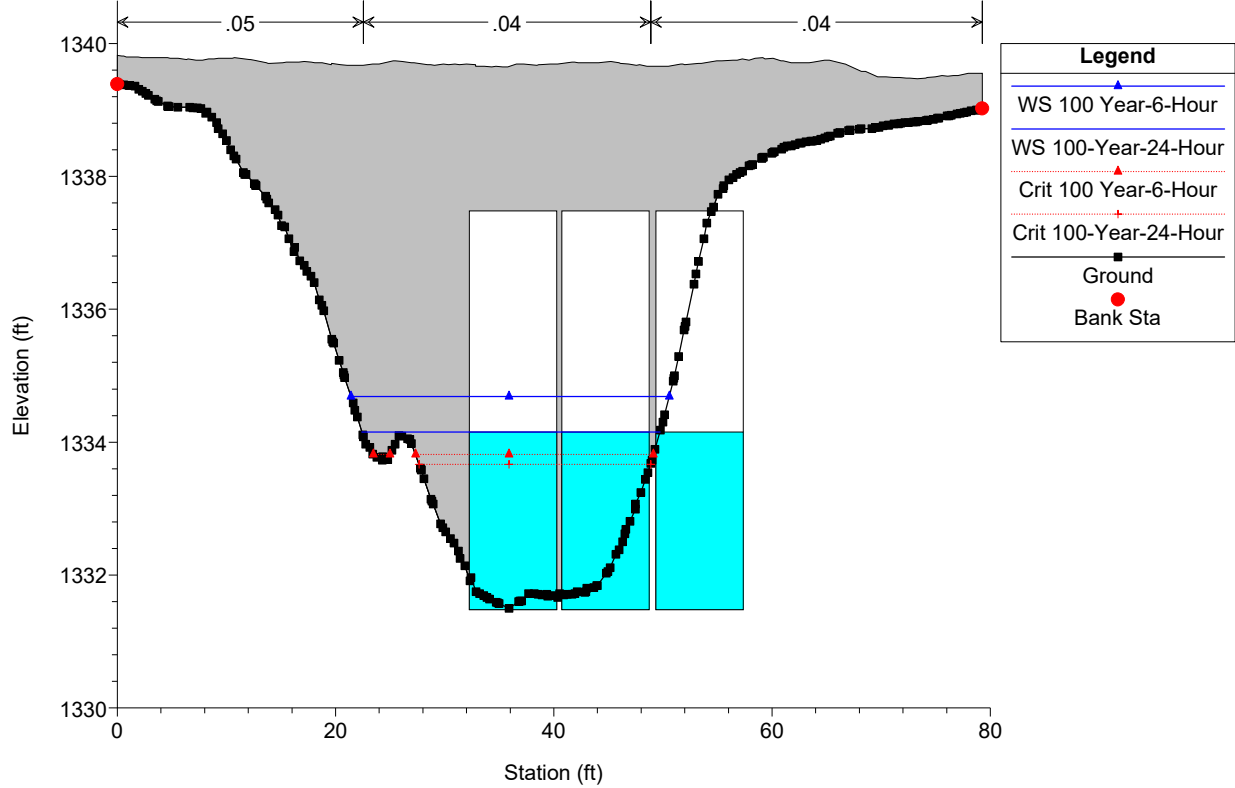
Gold Dust Aprt Plan: Gold Dust Aprt Pre-Project 9/1/2022
RS = 413



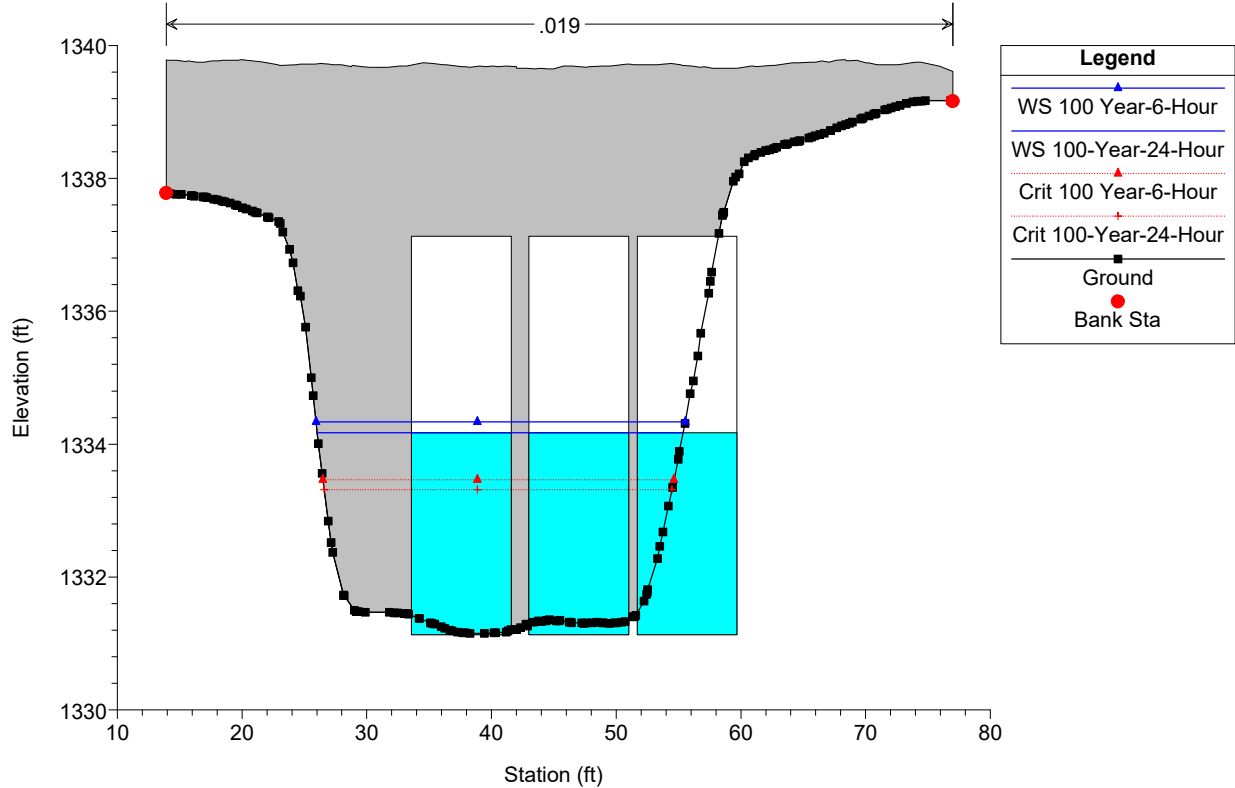
Gold Dust Aprt Plan: Gold Dust Aprt Pre-Project 9/1/2022
RS = 363

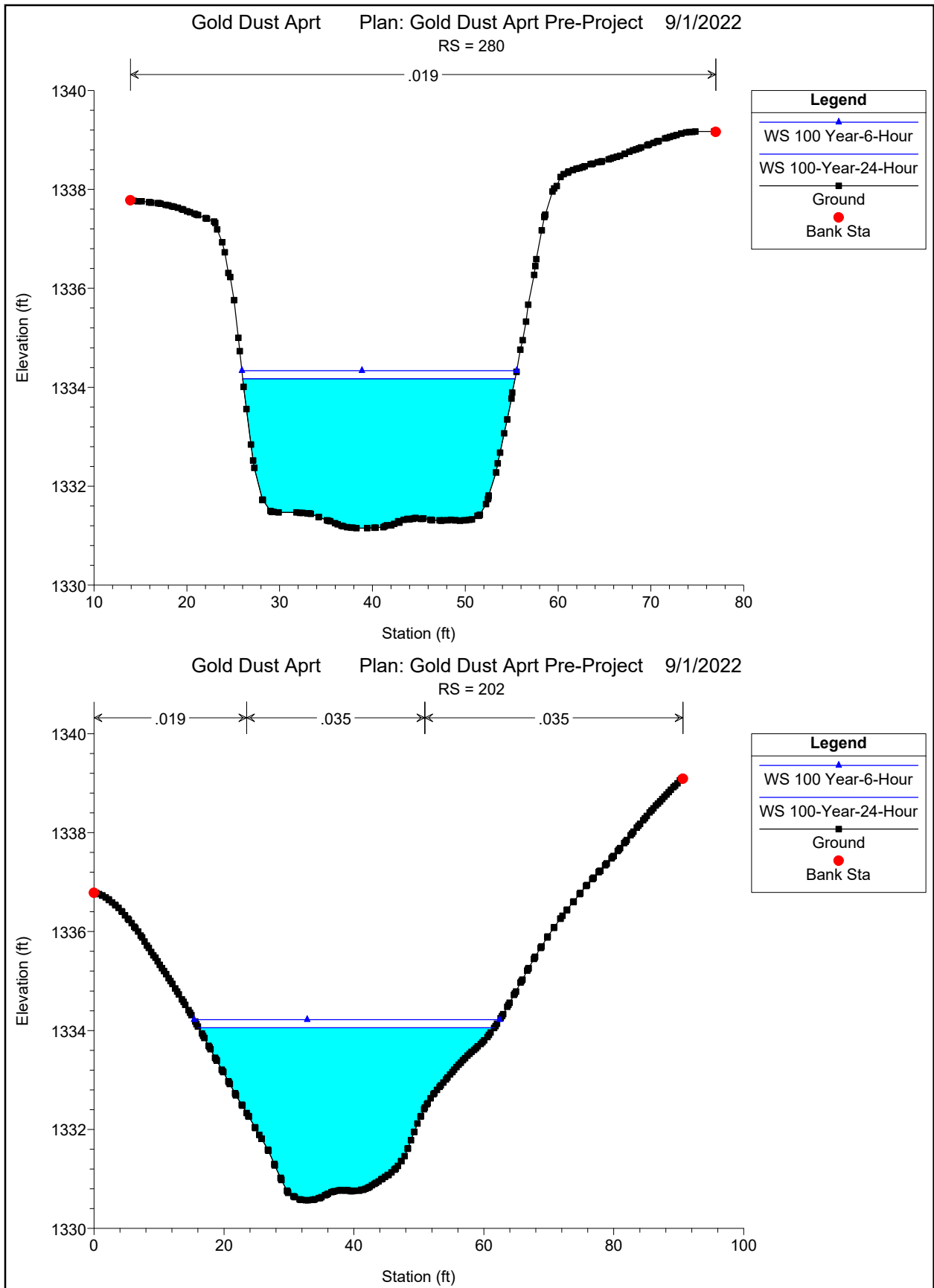


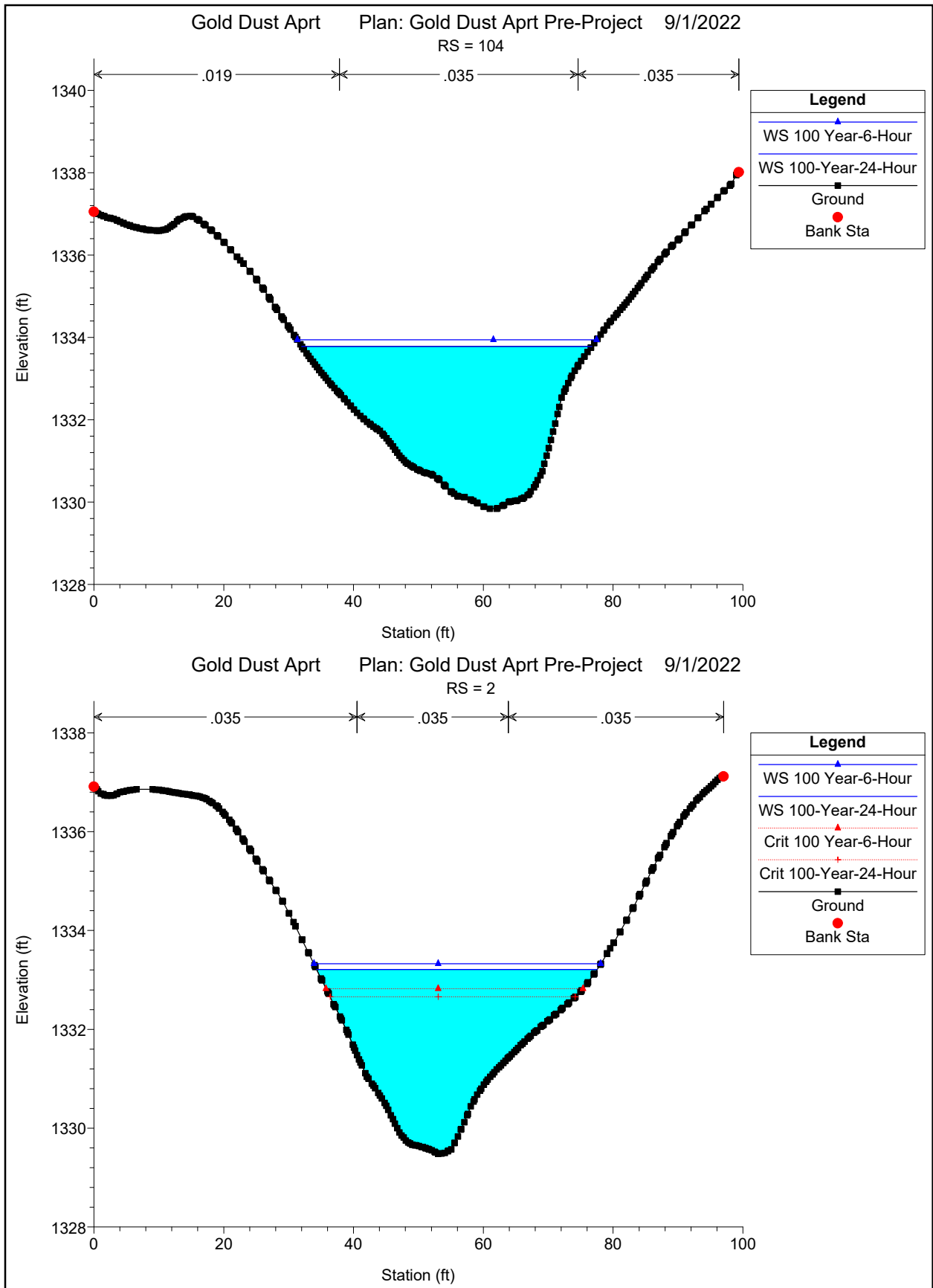
Gold Dust Aprt Plan: Gold Dust Aprt Pre-Project 9/1/2022
 RS = 326 Culv Mountain View Road

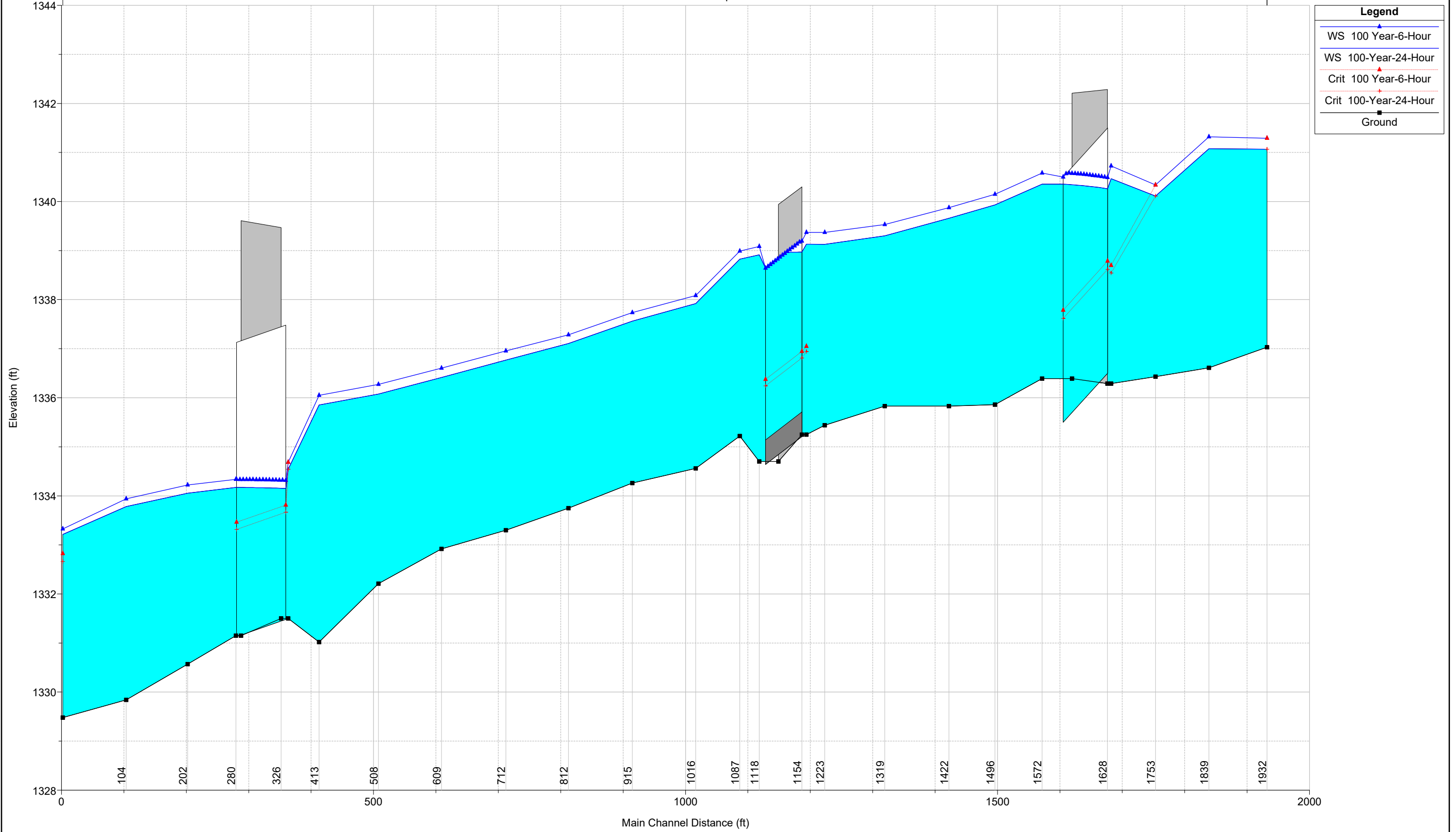


Gold Dust Aprt Plan: Gold Dust Aprt Pre-Project 9/1/2022
 RS = 326 Culv Mountain View Road









HEC-RAS Plan: Gold Dust Aprt Pre-Project River: Unnamed Wash Reach: Gold Dust Aprt.

| Reach | River Sta | Profile | Q Total (cfs) | Min Ch El (ft) | W.S. Elev (ft) | Crit W.S. (ft) | E.G. Elev (ft) | E.G. Slope (ft/ft) | Vel Chnl (ft/s) | Flow Area (sq ft) | Top Width (ft) | Froude # Chl |
|-----------------|-----------|------------------|------------------|-------------------|-------------------|-------------------|-------------------|-----------------------|--------------------|----------------------|-------------------|--------------|
| Gold Dust Aprt. | 1932 | 100-Year-24-Hour | 420.00 | 1337.03 | 1341.07 | 1341.07 | 1342.27 | 0.004485 | 8.79 | 47.80 | 20.25 | 1.01 |
| Gold Dust Aprt. | 1932 | 100 Year-6-Hour | 470.00 | 1337.03 | 1341.29 | 1341.29 | 1342.54 | 0.004416 | 8.97 | 52.42 | 21.29 | 1.01 |
| Gold Dust Aprt. | 1839 | 100-Year-24-Hour | 420.00 | 1336.61 | 1341.08 | | 1341.60 | 0.001441 | 5.78 | 72.73 | 24.75 | 0.59 |
| Gold Dust Aprt. | 1839 | 100 Year-6-Hour | 470.00 | 1336.61 | 1341.32 | | 1341.87 | 0.001450 | 5.96 | 78.84 | 25.66 | 0.60 |
| Gold Dust Aprt. | 1753 | 100-Year-24-Hour | 420.00 | 1336.43 | 1340.11 | 1340.11 | 1341.33 | 0.004452 | 8.84 | 47.52 | 19.89 | 1.01 |
| Gold Dust Aprt. | 1753 | 100 Year-6-Hour | 470.00 | 1336.43 | 1340.34 | 1340.34 | 1341.60 | 0.004325 | 9.02 | 52.13 | 20.67 | 1.00 |
| Gold Dust Aprt. | 1682 | 100-Year-24-Hour | 420.00 | 1336.29 | 1340.47 | 1338.54 | 1340.66 | 0.000451 | 3.51 | 119.65 | 37.06 | 0.34 |
| Gold Dust Aprt. | 1682 | 100 Year-6-Hour | 470.00 | 1336.29 | 1340.73 | 1338.70 | 1340.93 | 0.000447 | 3.63 | 129.33 | 37.49 | 0.34 |
| Gold Dust Aprt. | 1628 | | Culvert | | | | | | | | | |
| Gold Dust Aprt. | 1572 | 100-Year-24-Hour | 420.00 | 1336.39 | 1340.36 | | 1340.53 | 0.001221 | 3.33 | 126.25 | 39.36 | 0.33 |
| Gold Dust Aprt. | 1572 | 100 Year-6-Hour | 470.00 | 1336.39 | 1340.58 | | 1340.77 | 0.001232 | 3.48 | 135.15 | 39.98 | 0.33 |
| Gold Dust Aprt. | 1496 | 100-Year-24-Hour | 460.00 | 1335.86 | 1339.93 | | 1340.30 | 0.004799 | 4.86 | 94.61 | 39.88 | 0.56 |
| Gold Dust Aprt. | 1496 | 100 Year-6-Hour | 518.00 | 1335.86 | 1340.15 | | 1340.54 | 0.004845 | 5.01 | 103.41 | 42.38 | 0.57 |
| Gold Dust Aprt. | 1422 | 100-Year-24-Hour | 460.00 | 1335.83 | 1339.66 | | 1339.94 | 0.004353 | 4.22 | 108.98 | 43.95 | 0.47 |
| Gold Dust Aprt. | 1422 | 100 Year-6-Hour | 518.00 | 1335.83 | 1339.88 | | 1340.17 | 0.004312 | 4.37 | 118.61 | 45.11 | 0.47 |
| Gold Dust Aprt. | 1319 | 100-Year-24-Hour | 460.00 | 1335.83 | 1339.30 | | 1339.52 | 0.003524 | 3.72 | 123.51 | 53.19 | 0.43 |
| Gold Dust Aprt. | 1319 | 100 Year-6-Hour | 518.00 | 1335.83 | 1339.53 | | 1339.76 | 0.003419 | 3.81 | 136.03 | 55.14 | 0.43 |
| Gold Dust Aprt. | 1223 | 100-Year-24-Hour | 460.00 | 1335.44 | 1339.13 | | 1339.26 | 0.001741 | 2.93 | 157.05 | 65.27 | 0.33 |
| Gold Dust Aprt. | 1223 | 100 Year-6-Hour | 518.00 | 1335.44 | 1339.37 | | 1339.51 | 0.001667 | 2.99 | 172.99 | 66.29 | 0.33 |
| Gold Dust Aprt. | 1193 | 100-Year-24-Hour | 460.00 | 1335.25 | 1339.13 | 1336.94 | 1339.20 | 0.000639 | 2.14 | 214.93 | 68.02 | 0.21 |
| Gold Dust Aprt. | 1193 | 100 Year-6-Hour | 518.00 | 1335.25 | 1339.37 | 1337.05 | 1339.45 | 0.000636 | 2.24 | 231.26 | 68.63 | 0.21 |
| Gold Dust Aprt. | 1154 | | Culvert | | | | | | | | | |
| Gold Dust Aprt. | 1118 | 100-Year-24-Hour | 460.00 | 1334.70 | 1338.92 | | 1338.98 | 0.000436 | 1.98 | 232.89 | 80.40 | 0.20 |
| Gold Dust Aprt. | 1118 | 100 Year-6-Hour | 518.00 | 1334.70 | 1339.09 | | 1339.15 | 0.000460 | 2.10 | 246.73 | 81.52 | 0.21 |
| Gold Dust Aprt. | 1087 | 100-Year-24-Hour | 460.00 | 1335.22 | 1338.83 | | 1338.92 | 0.059473 | 2.45 | 187.61 | 68.45 | 0.26 |
| Gold Dust Aprt. | 1087 | 100 Year-6-Hour | 518.00 | 1335.22 | 1338.99 | | 1339.09 | 0.062155 | 2.60 | 198.88 | 69.91 | 0.27 |
| Gold Dust Aprt. | 1016 | 100-Year-24-Hour | 440.00 | 1334.56 | 1337.92 | | 1338.18 | 0.003942 | 4.10 | 107.43 | 51.38 | 0.50 |
| Gold Dust Aprt. | 1016 | 100 Year-6-Hour | 485.00 | 1334.56 | 1338.08 | | 1338.35 | 0.003834 | 4.18 | 115.95 | 52.85 | 0.50 |
| Gold Dust Aprt. | 915 | 100-Year-24-Hour | 440.00 | 1334.26 | 1337.56 | | 1337.79 | 0.003515 | 3.86 | 113.86 | 50.15 | 0.45 |
| Gold Dust Aprt. | 915 | 100 Year-6-Hour | 485.00 | 1334.26 | 1337.73 | | 1337.98 | 0.003448 | 3.96 | 122.63 | 51.46 | 0.45 |
| Gold Dust Aprt. | 812 | 100-Year-24-Hour | 440.00 | 1333.75 | 1337.11 | | 1337.38 | 0.004566 | 4.21 | 104.58 | 44.83 | 0.49 |
| Gold Dust Aprt. | 812 | 100 Year-6-Hour | 485.00 | 1333.75 | 1337.28 | | 1337.57 | 0.004487 | 4.31 | 112.64 | 45.83 | 0.48 |
| Gold Dust Aprt. | 712 | 100-Year-24-Hour | 440.00 | 1333.30 | 1336.77 | | 1337.00 | 0.002967 | 3.89 | 112.97 | 47.48 | 0.45 |
| Gold Dust Aprt. | 712 | 100 Year-6-Hour | 485.00 | 1333.30 | 1336.96 | | 1337.20 | 0.002917 | 3.98 | 121.93 | 48.81 | 0.44 |
| Gold Dust Aprt. | 609 | 100-Year-24-Hour | 440.00 | 1332.92 | 1336.41 | | 1336.66 | 0.003776 | 3.98 | 110.68 | 44.60 | 0.44 |
| Gold Dust Aprt. | 609 | 100 Year-6-Hour | 485.00 | 1332.92 | 1336.60 | | 1336.86 | 0.003740 | 4.07 | 119.22 | 45.88 | 0.44 |
| Gold Dust Aprt. | 508 | 100-Year-24-Hour | 440.00 | 1332.21 | 1336.08 | | 1336.29 | 0.003331 | 3.73 | 117.99 | 47.18 | 0.42 |
| Gold Dust Aprt. | 508 | 100 Year-6-Hour | 485.00 | 1332.21 | 1336.27 | | 1336.50 | 0.003264 | 3.81 | 127.36 | 48.43 | 0.41 |
| Gold Dust Aprt. | 413 | 100-Year-24-Hour | 440.00 | 1331.02 | 1335.85 | | 1336.02 | 0.002207 | 3.31 | 133.11 | 46.67 | 0.35 |
| Gold Dust Aprt. | 413 | 100 Year-6-Hour | 485.00 | 1331.02 | 1336.05 | | 1336.23 | 0.002225 | 3.41 | 142.39 | 47.82 | 0.35 |
| Gold Dust Aprt. | 363 | 100-Year-24-Hour | 440.00 | 1331.50 | 1334.54 | 1334.54 | 1335.53 | 0.020865 | 7.97 | 55.23 | 28.69 | 1.01 |
| Gold Dust Aprt. | 363 | 100 Year-6-Hour | 485.00 | 1331.50 | 1334.69 | 1334.69 | 1335.72 | 0.020559 | 8.17 | 59.34 | 29.18 | 1.01 |
| Gold Dust Aprt. | 326 | | Culvert | | | | | | | | | |
| Gold Dust Aprt. | 280 | 100-Year-24-Hour | 440.00 | 1331.15 | 1334.17 | | 1334.70 | 0.001704 | 5.80 | 75.90 | 29.35 | 0.64 |
| Gold Dust Aprt. | 280 | 100 Year-6-Hour | 485.00 | 1331.15 | 1334.34 | | 1334.90 | 0.001718 | 6.01 | 80.70 | 29.62 | 0.64 |
| Gold Dust Aprt. | 202 | 100-Year-24-Hour | 470.00 | 1330.57 | 1334.05 | | 1334.43 | 0.003746 | 4.94 | 95.12 | 45.49 | 0.60 |
| Gold Dust Aprt. | 202 | 100 Year-6-Hour | 526.00 | 1330.57 | 1334.22 | | 1334.63 | 0.003769 | 5.12 | 102.82 | 47.04 | 0.61 |
| Gold Dust Aprt. | 104 | 100-Year-24-Hour | 470.00 | 1329.84 | 1333.78 | | 1334.08 | 0.002946 | 4.42 | 106.32 | 44.71 | 0.51 |
| Gold Dust Aprt. | 104 | 100 Year-6-Hour | 526.00 | 1329.84 | 1333.94 | | 1334.27 | 0.003020 | 4.63 | 113.58 | 46.12 | 0.52 |
| Gold Dust Aprt. | 2 | 100-Year-24-Hour | 470.00 | 1329.48 | 1333.21 | 1332.66 | 1333.68 | 0.005215 | 5.47 | 85.96 | 43.24 | 0.68 |
| Gold Dust Aprt. | 2 | 100 Year-6-Hour | 526.00 | 1329.48 | 1333.33 | 1332.82 | 1333.85 | 0.005621 | 5.79 | 90.86 | 44.19 | 0.71 |



Appendix H – SCOUR AND LATERAL MIGRATION POTENTIAL CALCULATIONS

Channel Riprap Sizing

FCDMC Drainage Desing Manual for Maricopa County - Hydraulics 2018

6.6.3 Riprap Lined Channels

Channel Bank, Loose Angular Riprap Sizing (d50)

Input Parameters:

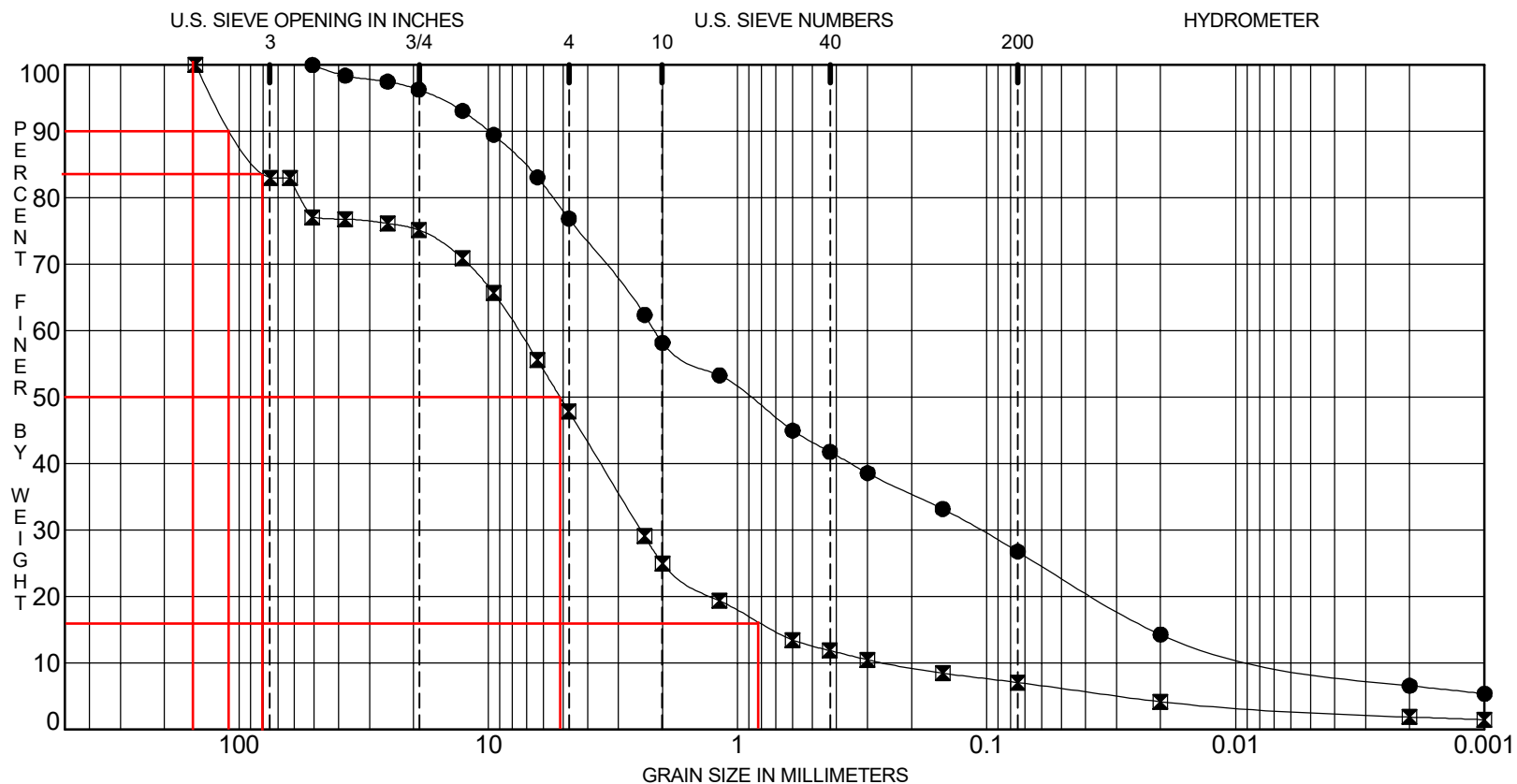
| | | | |
|---|------|---------|---|
| V _m , Maximum Channel Velocity | 5.0 | ft/s | (Max Vel from HEC-RAS Flow Dist Analysis is Entered Here) |
| γ _s , Spec Weight Stone | 156 | | |
| φ, Bank Angle (from Horizontal) | 18.4 | Degrees | |
| C, Turbulence Coefficient | 1.2 | | (Use 1.2 for low turbulence, 0.86 for high turbulence) |
| Minimum D ₅₀ | 0.19 | ft | Use 4" Rock |

Calculated By:

JEP

Date: 1/30/2023

GRADATION CURVES



| COBBLES | GRAVEL | | SAND | | | SILT OR CLAY |
|---------|--------|------|--------|--------|------|--------------|
| | coarse | fine | coarse | medium | fine | |

BANK

BED

| Specimen Identification | ASTM Classification | LL | PL | PI | %Gravel | %Sand | %Fines | |
|-------------------------|---|-------|----|----|---------|-------|--------|------|
| ● TP-1 0.0 | CLAYEY SAND with GRAVEL | SC | 40 | 20 | 20 | 23.1 | 50.1 | 26.8 |
| ✕ TP-2 0.0 | POORLY GRADED SAND with CLAY and GRAVEL | SP-SC | 40 | 22 | 19 | 35.1 | 40.8 | 7.1 |

Gold Dust Apartments - Unnamed Wash Scour Summary

Dibble

Channel Scour

| HEC-RAS Cross Section | General Scour ¹ (ft) | Bend Scour ² (ft) | Bedform Scour ³ (ft) | Long Term Scour ⁴ (ft) | Low Flow Thalweg ⁵ (ft) | Local Scour ⁶ (ft) | Safety Factor ⁷ | Total Scour Depth ⁸ (ft) |
|-----------------------|---------------------------------|------------------------------|---------------------------------|-----------------------------------|------------------------------------|-------------------------------|----------------------------|-------------------------------------|
| 1496 | 1.7 | 0.0 | 0.1 | 0.0 | 0.0 | 0.0 | 1.3 | 2.3 |
| 1422 | 1.7 | 0.0 | 0.1 | 0.0 | 0.0 | 0.0 | 1.3 | 2.3 |
| 1319 | 1.7 | 0.0 | 0.1 | 0.0 | 0.0 | 0.0 | 1.3 | 2.3 |
| 1223 | 1.7 | 0.0 | 0.1 | 0.0 | 0.0 | 0.0 | 1.3 | 2.3 |
| | | | | | | | | |
| | | | | | | | | |
| | | | | | | | | |
| | | | | | | | | |
| | | | | | | | | |
| | | | | | | | | |

¹General scour calculated using Blench Equation, see attached.

²A moderate bend is included in the General Scour computation using Blench Equation

³Bedform Scour per USBR Dune and Anti-Dune Scour Height Calculations, see attached.

⁴Longterm Scour is set to zero due to immediate downstream control.

⁵Low Flow Scour is appropriate for constructed channels; scour depth is applied to the lowest point in each natural wash cross section, so Low Flow Scour has

⁶Local Control Scour depth - there are no local scour sources in the subject reach.

⁷A safety factor equal to 1.3 per Flood Control District of Maricopa County Drainage Design Manual - Hydraulics.

⁸Total Scour Depth is equal to the sum of General, Bend, Bedform, Long Term, Low Flow, and Local multiplied by the Safety Factor. Depth is applied to lowets

Soils Data:

| Sediment Gradation | |
|--------------------|---------|
| D (mm) | % Finer |
| 170.00 | 100 |
| 110.00 | 90 |
| 80.00 | 84 |
| 5.00 | 50 |
| 0.80 | 16 |

Calculated By:

JEP

Date:

1.30.2023

General Scour Calculations - USBR

* Methodology from US Bureau of Reclamation, "Computing Degradation and Local Scour", 1984 *

Blench Equation:

$$d_s = Z \frac{q_f^{2/3}}{F_{bo}^{1/3}}$$

Where:

ds = Scour Depth Below Streambed (ft)
 Z = Regime Modifier (See Table Below)
 * Moderate bend assumed *

Lacey Equation:

$$d_s = 0.47Z \left(\frac{Q}{1.76D_m^{1/2}} \right)^{1/3}$$

qf = Unit Discharge (Q/Top Width)
 Fbo = Blench's "zero bed factor" (ft/s²)
 Q = Design Discharge (cfs)
 Dm = Mean Grain Size of Bed Material (mm)
 Vm = Mean Channel Velocity (ft/s)
 Vc = Channel Competent Velocity (ft/s)
 dm = Mean Depth (ft)

Competent Velocity Equation:

$$d_s = d_m \left(\frac{V_m}{V_c} - 1 \right)$$

Input Parameters

| | |
|--|------------------------|
| Dm | 5.00 mm |
| ⁴ Longterm Scour is set to zero | 518 cfs |
| Z | 0.6 |
| ⁶ Local Control Scour depth | 2.70 ft/s ² |
| Top Width | 69 ft |
| Vc | - ft/s |
| Vm | - ft/s |
| dm | - ft |

Scour Depths (from Channel Bottom)

| | | |
|----------------|---------|---|
| Blench: | 1.66 ft | 1 |
| Lacey: | N/A ft | 2 |
| Competent Vel: | N/A ft | 3 |

1,2,3 1 Blench Method selected over Lacey and Competent Velocity methods.

Regime Modifier (Z)

| Equation Types A and B | Equation Name | | |
|----------------------------|---------------|-------|--------|
| | Neill | Lacey | Blench |
| Straight Reach | 0.5 | 0.25 | 0.6 |
| Moderate bend | 0.6 | 0.5 | 0.6 |
| Severe Bend | 0.7 | 0.75 | 0.6 |
| Right angle bends | | 1 | 1.25 |
| Vertical rock bank or wall | | 1.25 | |

Equation Types C and D

| | | | |
|-----------------------------------|---------|----------|-----------|
| Nose of piers | 1 | | 0.5-1.0 |
| Nose of guide banks | 0.4-0.7 | 1.5-1.75 | 1.0-1.75 |
| Small dam or control across river | | 1.5 | 0.75-1.25 |

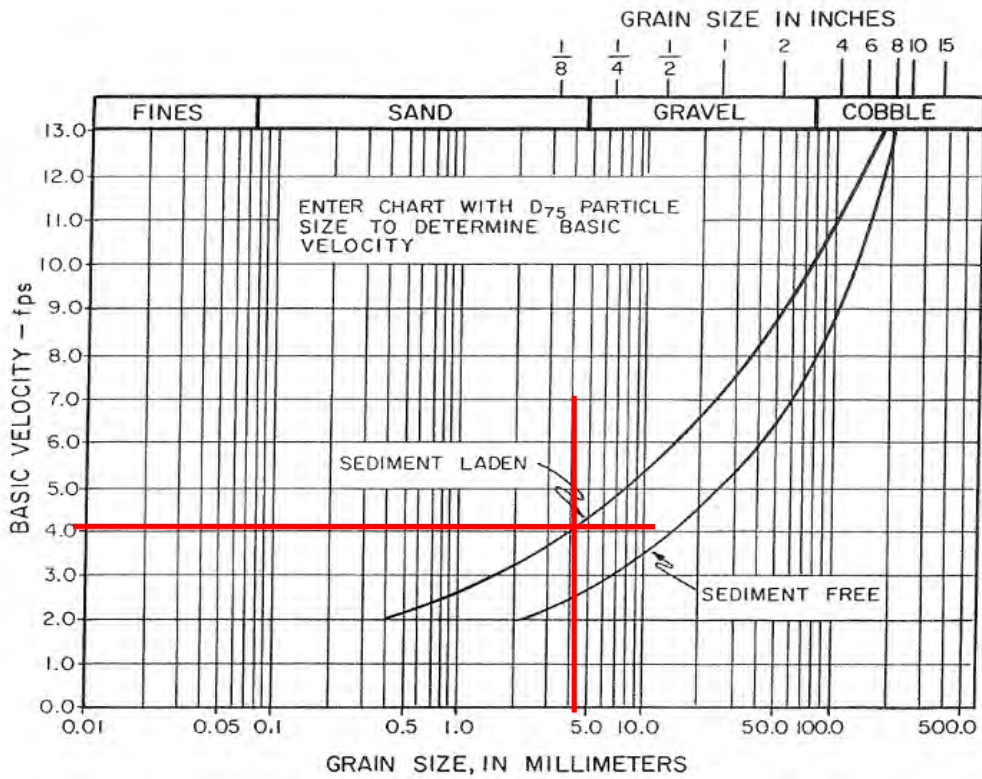
**Lateral Migration Setback Allowance for Riverine Floodplains
Level 2 Analysis**

Cross Section 1193 - General Information

| | | | |
|-------------------------|------------------|--------------|------------|
| Bottom Width (b) | 60 feet | | |
| Side Slope (ft) | 22.9 Horizontal | 4.3 Vertical | |
| Channel Slope (S_e) | 0.0004 feet/foot | | |
| Radius of Curvature (r) | 0 feet | | |
| Water Surface Width | 68.63 feet | | |
| Average Manning's n | 0.042 | | |
| | | | |
| Flow Depth (Y) | 4.12 feet | | |
| Flow Velocity (V) | 2.24 feet/second | | |
| | | | |
| D_{75} | 4.4 mm | 0.17 inches | 0.014 feet |
| D_{65} | 3.7 mm | 0.15 inches | 0.012 feet |
| D_{50} | 0.9 mm | 0.04 inches | 0.003 feet |

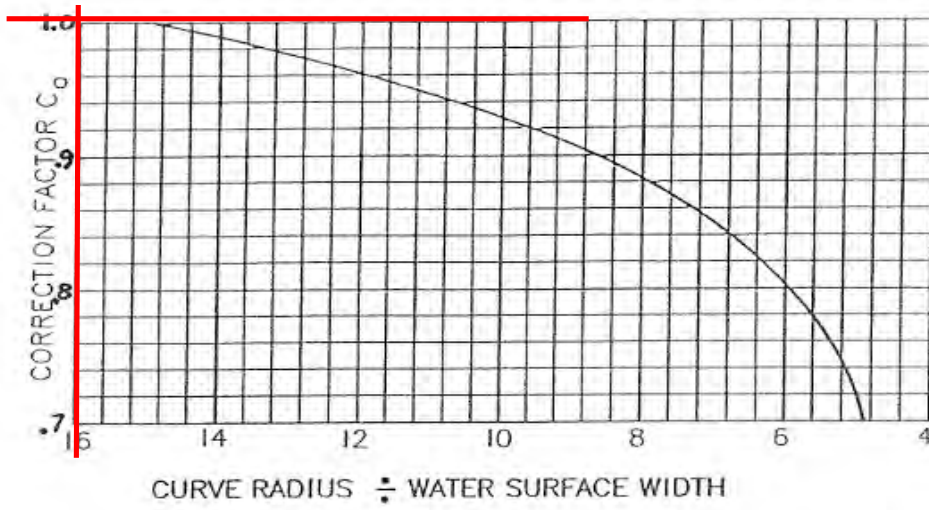
**Allowable Velocity Approach
(Assuming Sediment Laden Flow)**

Base Allowable Velocity for Earth Channels V_b 4.2 feet/sec



Correction Factor C_a For Channel Alignment

1

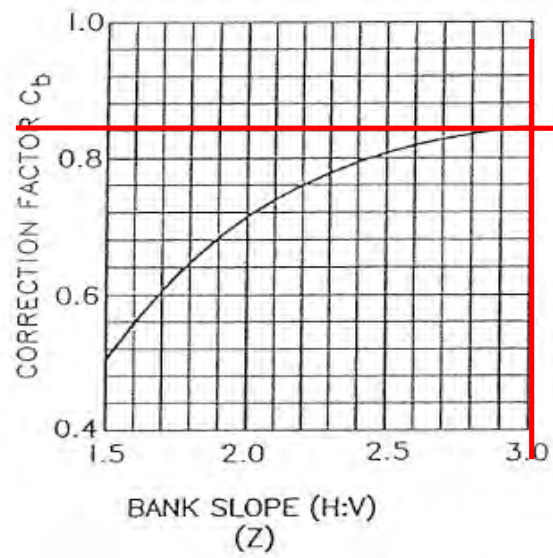


Curve Radius / Water Surface Width

0.0

Correction Factor C_b For Bank Slope

0.84

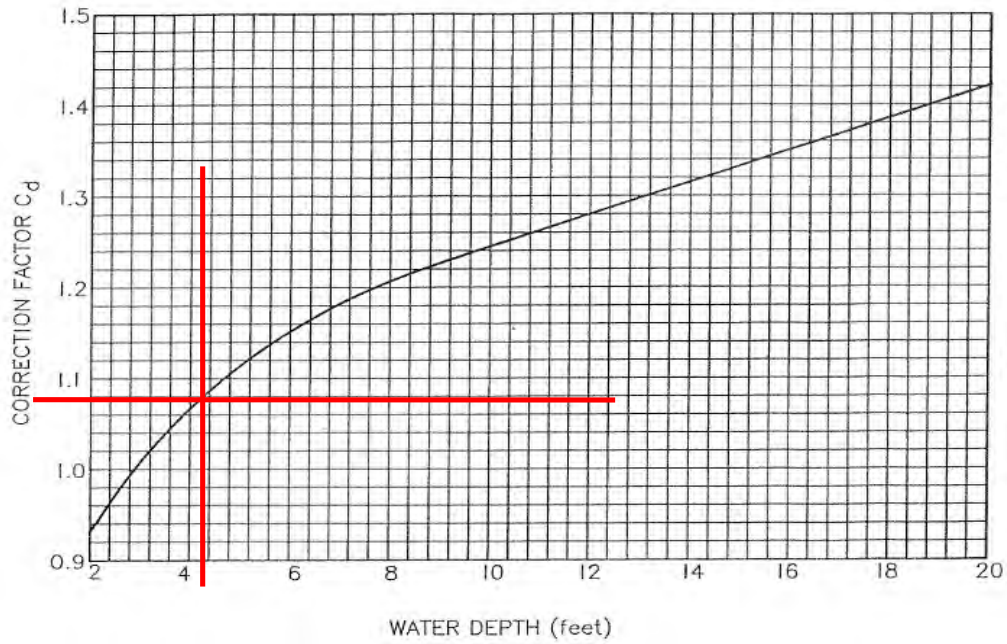


Horizontal/Vertical (Z)

5.33

Correction Factor C_d For Depth of Flow

1.08



Flow Depth (Y)

4.12 feet

Maximum Allowable Velocity

3.81

feet/second

$$V_a = V_b \times C_a \times C_b \times C_d$$

Comparison of Flow Velocity of the Channel to the Maximum Allowable Velocity

Maximum Allowable Velocity

3.81

feet/second

Flow Velocity

2.24

feet/second

Since the computed flow velocity is less than the maximum allowable velocity, erosion is not expected to occur.

**Tractive Stress Analysis
(Assuming Sediment Laden Flow)**

D_{75} 4.4 mm conversion 0.17 inches

Since D_{75} is less or equal to 0.25 inches, case 2 of reference tractive stress method is used.

Assuming a water temperature of 60°F

Kinematic Velocity (v) 0.0000121 ft² / sec
 Density (ρ) 1.94 slugs/ft³
 Gravity 32.17 ft/sec²

Finding Values Needed for Graphs

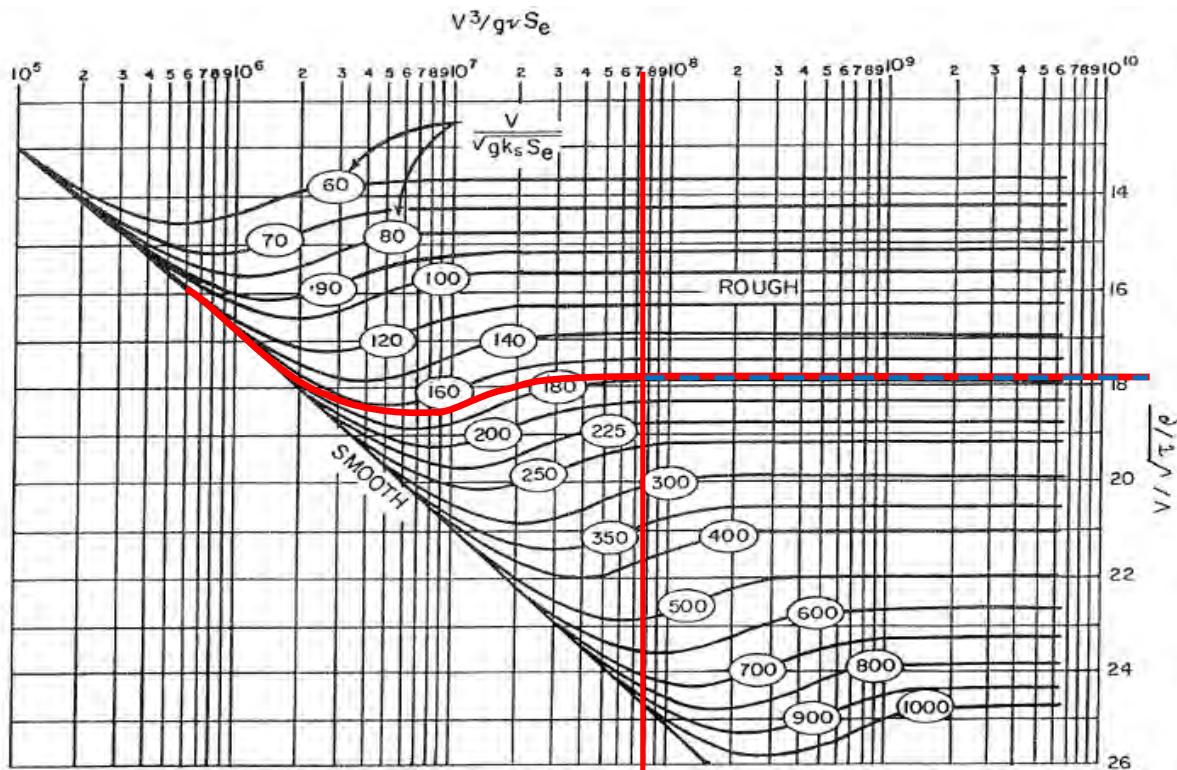
$$V^3 / (g v S_e)$$

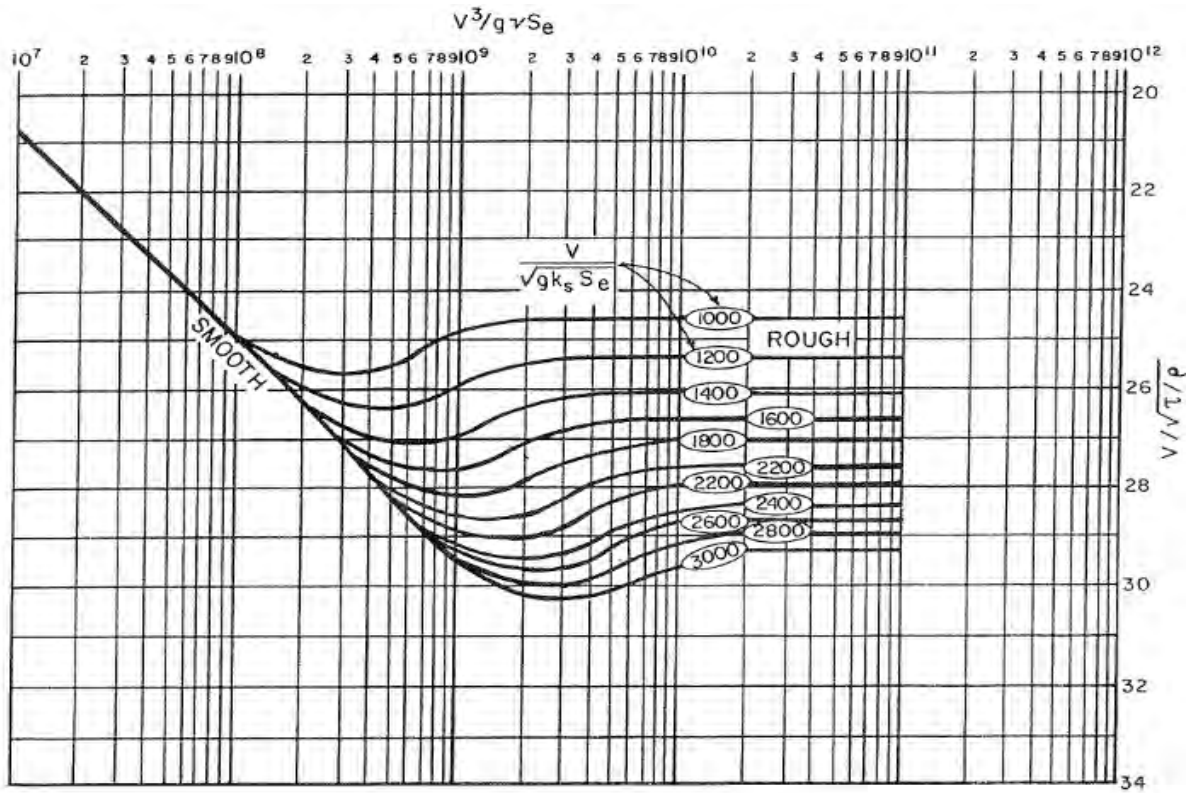
Value 1 7.22E+07

$$V / [(g D_{65} S_e)^{0.5}]$$

Value 2 179.2

Graphic Solution of Reference Tractive Stress



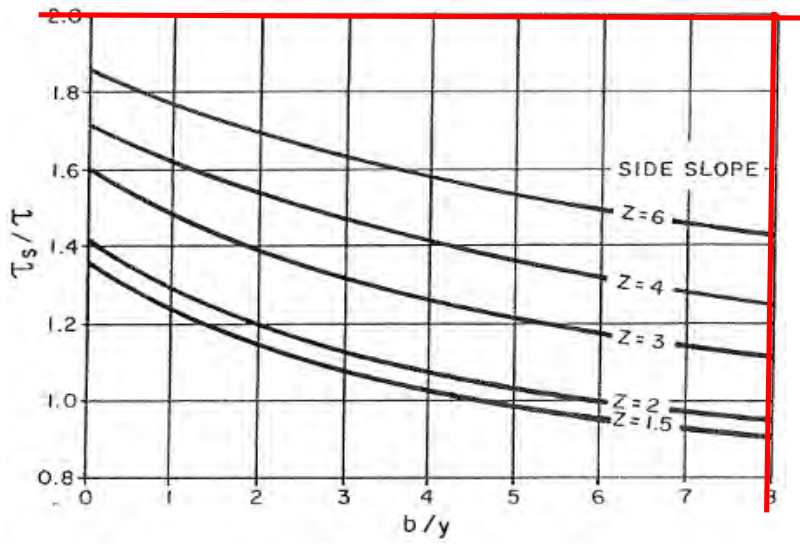


$$V/\sqrt{\tau/\rho}$$

From Graph Above 17.8

Solving the above equation for τ 0.03 lb/ft²

Applied Maximum Tractive Stress, τ_s , on sides of straight trapezoidal channels

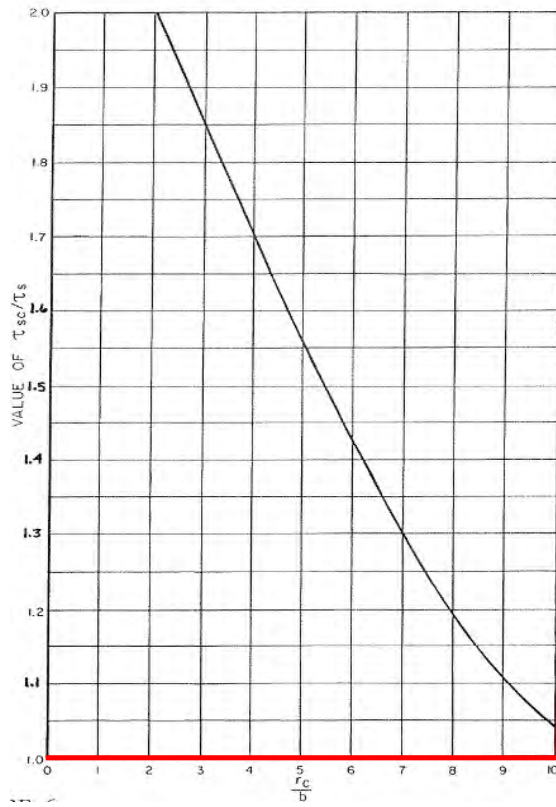


Bottom Width/Flow depth 14.56
Horizontal/Vertical (Z) 5.33

From Graph 2

Solving for τ_s 0.06 lb/ft²

Actual Maximum Tractive Stress, τ_s on sides of trapezoidal channels within a curved reach



Radius of Curvature/Bottom Width

N/A

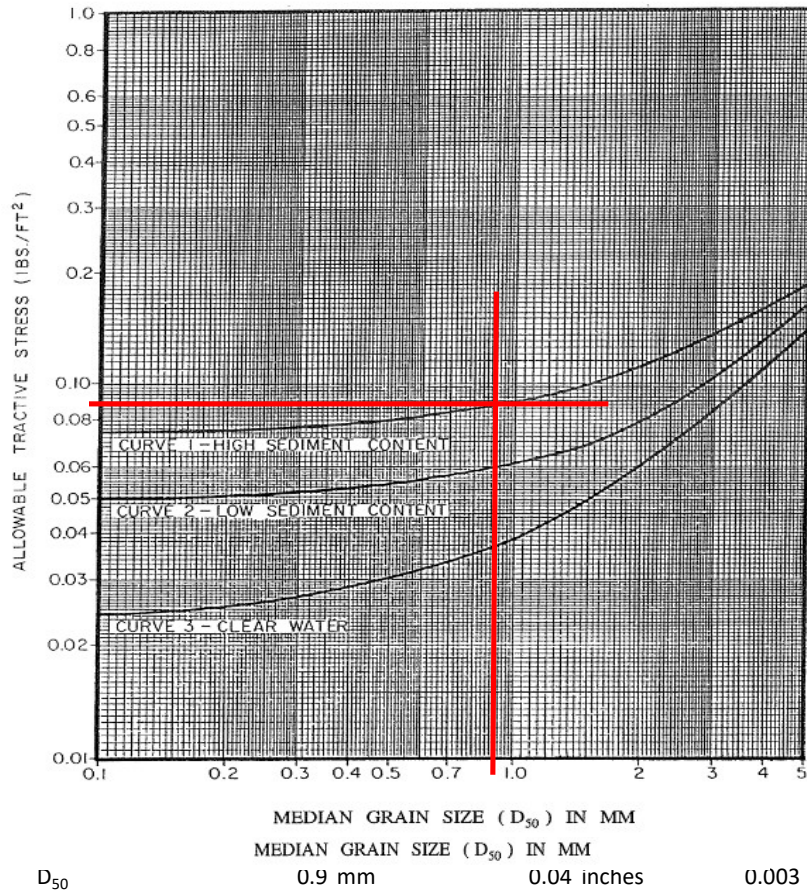
From Graph Above

1.00

Solving for τ_s

0.06 lb/ft²

Maximum Allowable Tractive Stress For Non-Cohesive Soils, $D_{75} < 0.25''$



Allowable Tractive Stress, from graph above 0.092 lb/ft²

Calculated Tractive Stress, τ 0.03 lb/ft²

Since the allowable tractive stress is more than the calculated tractive stress, the channel is not erosive.

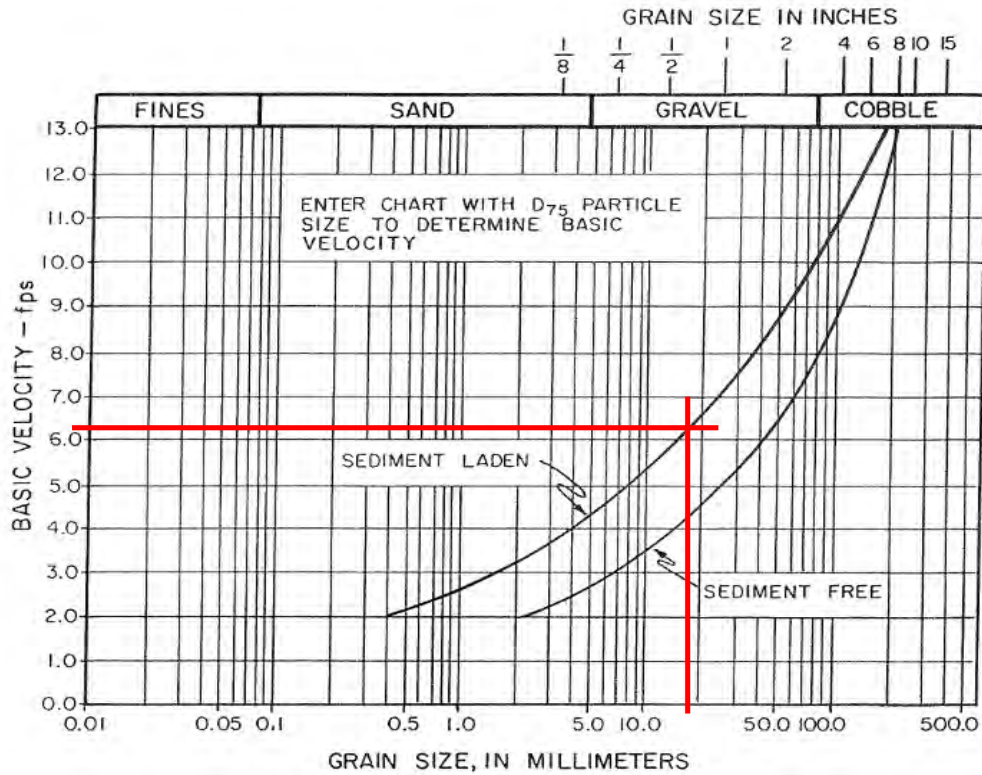
**Lateral Migration Setback Allowance for Riverine Floodplains
Level 2 Analysis**

Cross Section 1193 - General Information

| | | | |
|-------------------------|------------------|--------------|------------|
| Bottom Width (b) | 60 feet | | |
| Side Slope (ft) | 22.9 Horizontal | 4.3 Vertical | |
| Channel Slope (S_e) | 0.0004 feet/foot | | |
| Radius of Curvature (r) | 0 feet | | |
| Water Surface Width | 68.63 feet | | |
| Average Manning's n | 0.042 | | |
| | | | |
| Flow Depth (Y) | 4.12 feet | | |
| Flow Velocity (V) | 2.24 feet/second | | |
| | | | |
| D_{75} | 19 mm | 0.75 inches | 0.062 feet |
| D_{65} | 9.1 mm | 0.36 inches | 0.030 feet |
| D_{50} | 5.2 mm | 0.20 inches | 0.017 feet |

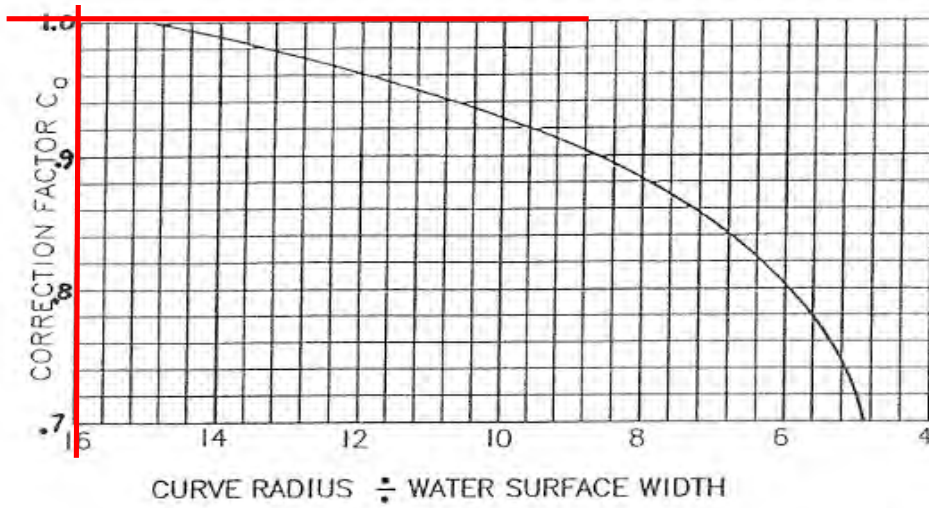
**Allowable Velocity Approach
(Assuming Sediment Laden Flow)**

Base Allowable Velocity for Earth Channels V_b 6.3 feet/sec



Correction Factor C_a For Channel Alignment

1

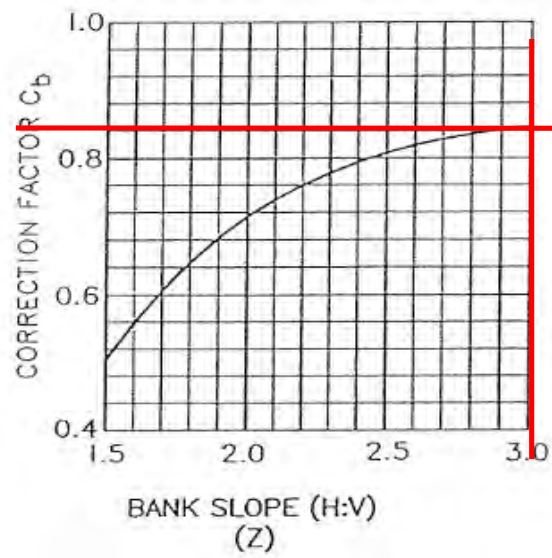


Curve Radius / Water Surface Width

0.0

Correction Factor C_b For Bank Slope

0.84

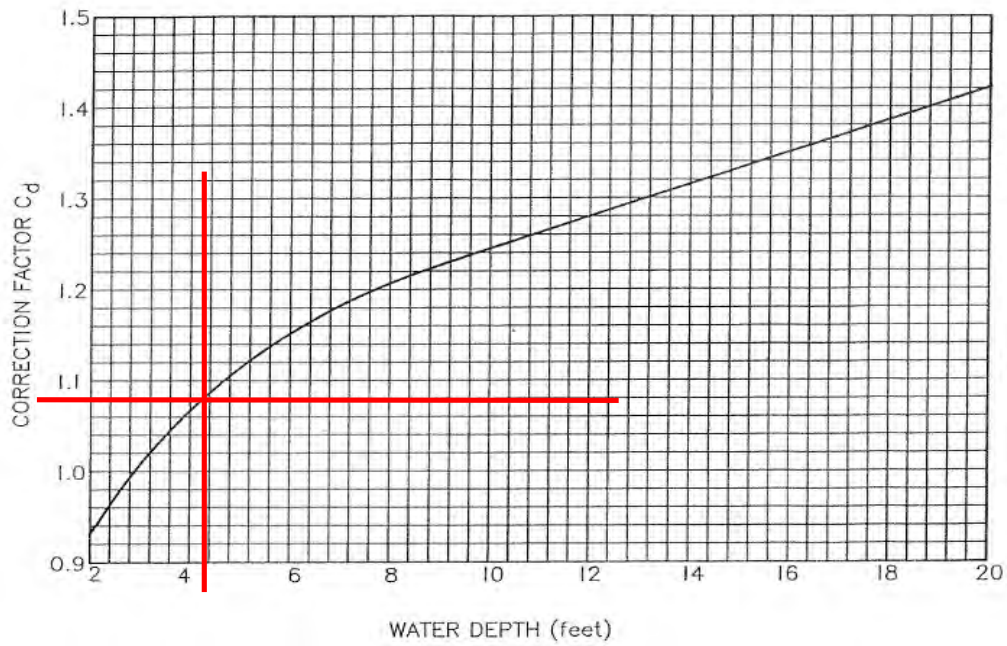


Horizontal/Vertical (Z)

5.33

Correction Factor C_d For Depth of Flow

1.08



Flow Depth (Y)

4.12 feet

Maximum Allowable Velocity

5.72

feet/second

$$V_a = V_b \times C_a \times C_b \times C_d$$

Comparison of Flow Velocity of the Channel to the Maximum Allowable Velocity

Maximum Allowable Velocity

5.72

feet/second

Flow Velocity

2.24

feet/second

Since the computed flow velocity is less than the maximum allowable velocity, erosion is not expected to occur.

**Tractive Stress Analysis
(Assuming Sediment Laden Flow)**

D₇₅ 19 mm conversion 0.75 inches

Since the D₇₅ is more than 0.25 inches and less than 5.0 inches, case 1 of the reference tractive method is used.

Assuming a water temperature of 60°F

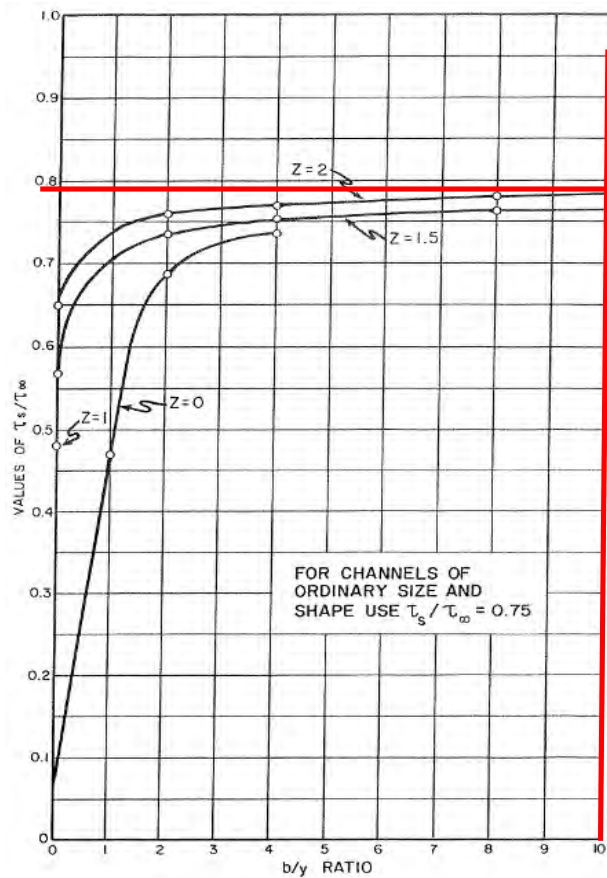
Kinematic Velocity (v) 0.0000121 ft² / sec
 Density (ρ) 1.94 slugs/ft³
 Gravity 32.17 ft/sec²
 Unit Weight of Water (γ) 62.4 lbs/ft³

Tractive Stress for Soils in an infinitely Wide Channel (τ_∞)

$$\gamma_w Y \left[\frac{D_{75}^{\frac{1}{6}}}{39n} \right]^2 S_e$$

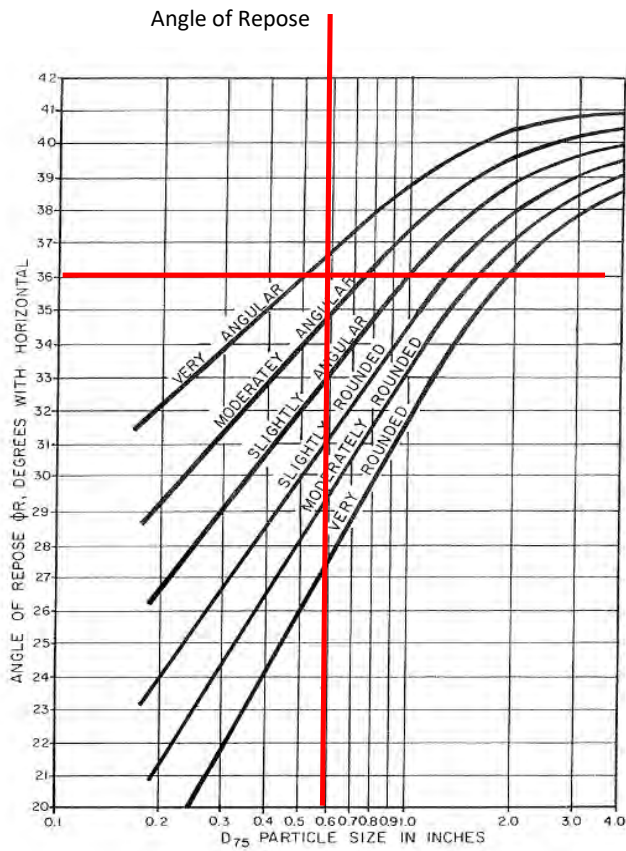
0.015 lbs/ft²

Actual Maximum Tractive Stress, τ_s on Sides of Straight Trapezoidal Channels



b/y Ratio 14.56 ft/ft
 Z (H/V) 5.33 ft/ft
 τ_s/τ_∞ 0.79
 τ_s 0.012 lbs/ft²

Allowable Tractive Stress (τ_{ls})



Moderately Angular
 D_{75} 0.75 inches
 From Chart (ϕR) 36 Degrees

Solving for Allowable Tractive Stress

$$0.4 \left[\frac{Z^2 - \text{Cot}^2 \phi R}{1 + Z^2} \right]^{\frac{1}{2}} D_{75}$$

0.279 lbs/ft²

Allowable Tractive Stress, from calculation above 0.279 lb/ft²

Calculated Tractive Stress, τ 0.012 lb/ft²

Since the allowable tractive stress is more than the calculated tractive stress, the channel is not erosive.

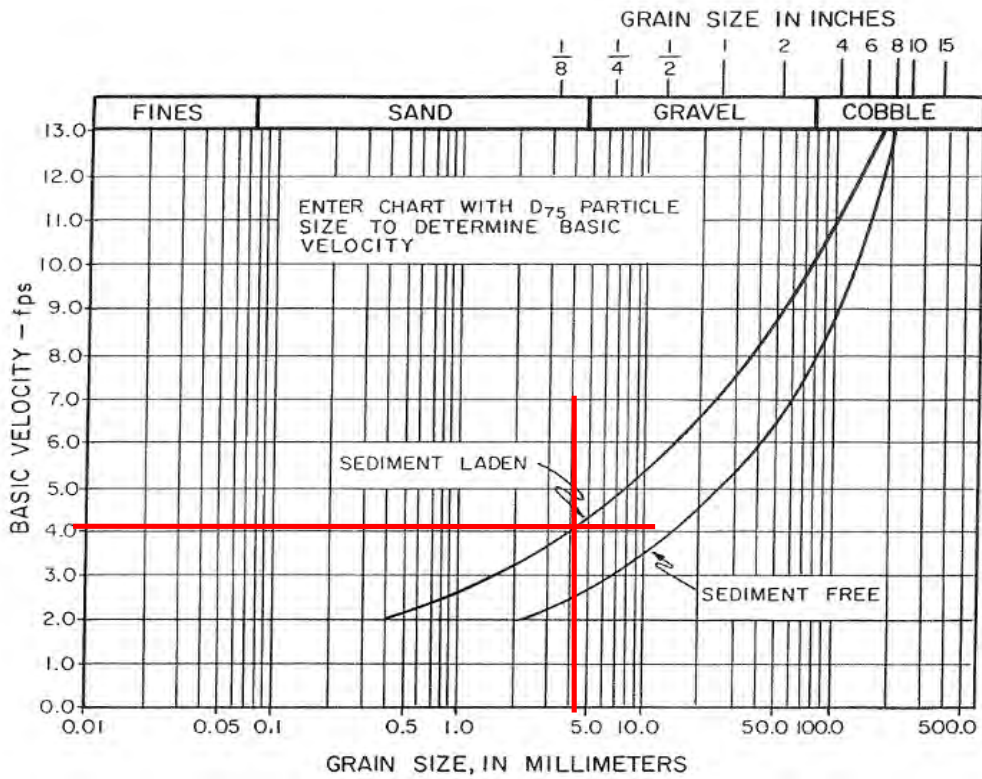
**Lateral Migration Setback Allowance for Riverine Floodplains
Level 2 Analysis**

Cross Section 1223 - General Information

| | | | |
|-------------------------|------------------|--------------|------------|
| Bottom Width (b) | 35.9 feet | | |
| Side Slope (ft) | 30 Horizontal | 3.7 Vertical | |
| Channel Slope (S_e) | 0.001 feet/foot | | |
| Radius of Curvature (r) | 0 feet | | |
| Water Surface Width | 66.29 feet | | |
| Average Manning's n | 0.042 | | |
| | | | |
| Flow Depth (Y) | 3.93 feet | | |
| Flow Velocity (V) | 2.99 feet/second | | |
| | | | |
| D_{75} | 4.4 mm | 0.17 inches | 0.014 feet |
| D_{65} | 3.7 mm | 0.15 inches | 0.012 feet |
| D_{50} | 0.9 mm | 0.04 inches | 0.003 feet |

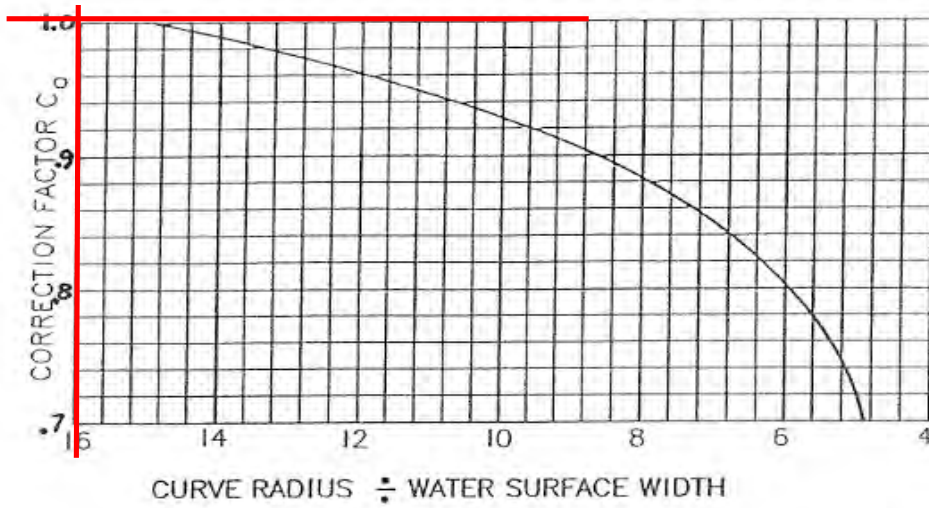
**Allowable Velocity Approach
(Assuming Sediment Laden Flow)**

Base Allowable Velocity for Earth Channels V_b 4.2 feet/sec



Correction Factor C_a For Channel Alignment

1

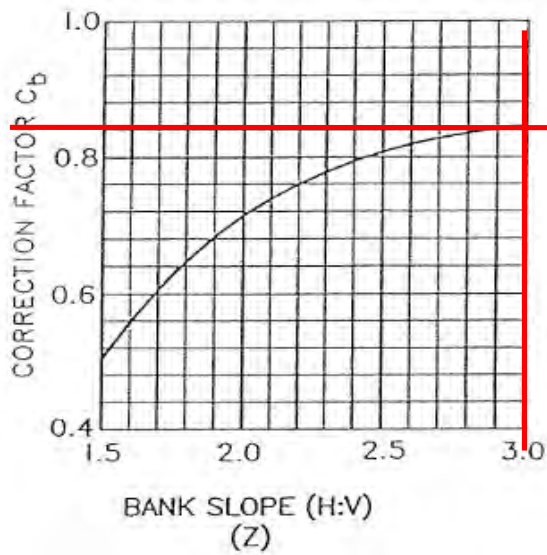


Curve Radius / Water Surface Width

0.0

Correction Factor C_b For Bank Slope

0.84

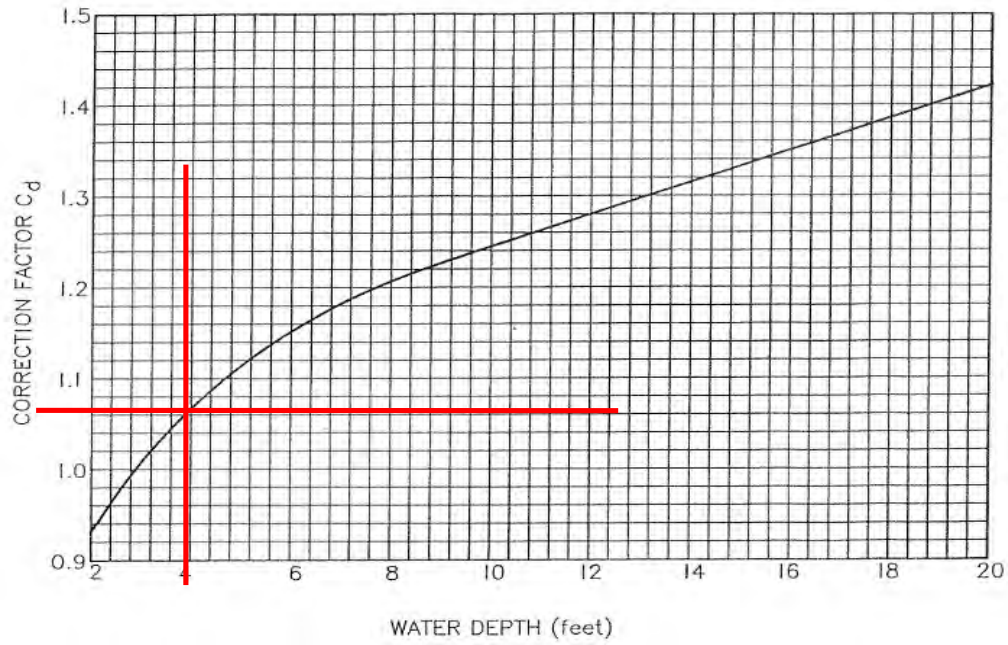


Horizontal/Vertical (Z)

8.11

Correction Factor C_d For Depth of Flow

1.06



Flow Depth (Y)

3.93 feet

Maximum Allowable Velocity

3.74

feet/second

$$V_a = V_b \times C_a \times C_b \times C_d$$

Comparison of Flow Velocity of the Channel to the Maximum Allowable Velocity

Maximum Allowable Velocity

3.74

feet/second

Flow Velocity

2.99

feet/second

Since the computed flow velocity is less than the maximum allowable velocity, erosion is not expected to occur.

**Tractive Stress Analysis
(Assuming Sediment Laden Flow)**

D_{75} 4.4 mm conversion 0.17 inches

Since D_{75} is less or equal to 0.25 inches, case 2 of reference tractive stress method is used.

Assuming a water temperature of 60°F

Kinematic Velocity (v) 0.0000121 ft² / sec
 Density (ρ) 1.94 slugs/ft³
 Gravity 32.17 ft/sec²

Finding Values Needed for Graphs

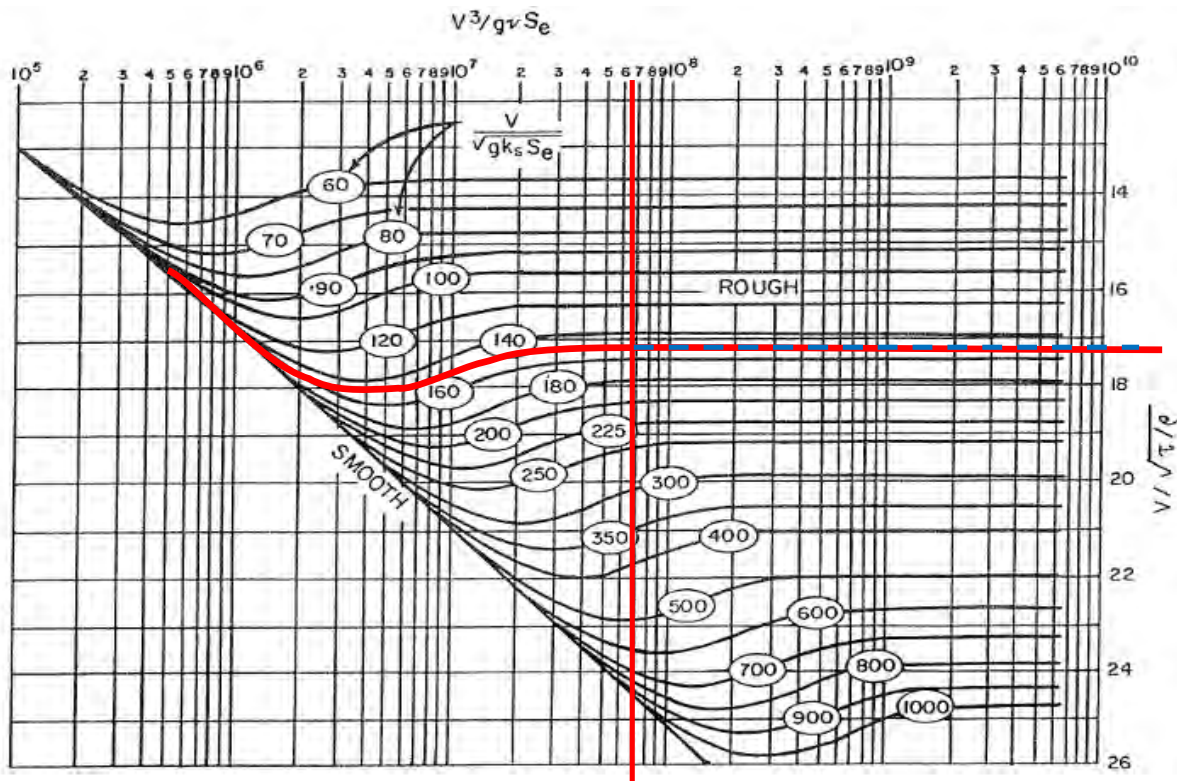
$$V^3 / (g v S_e)$$

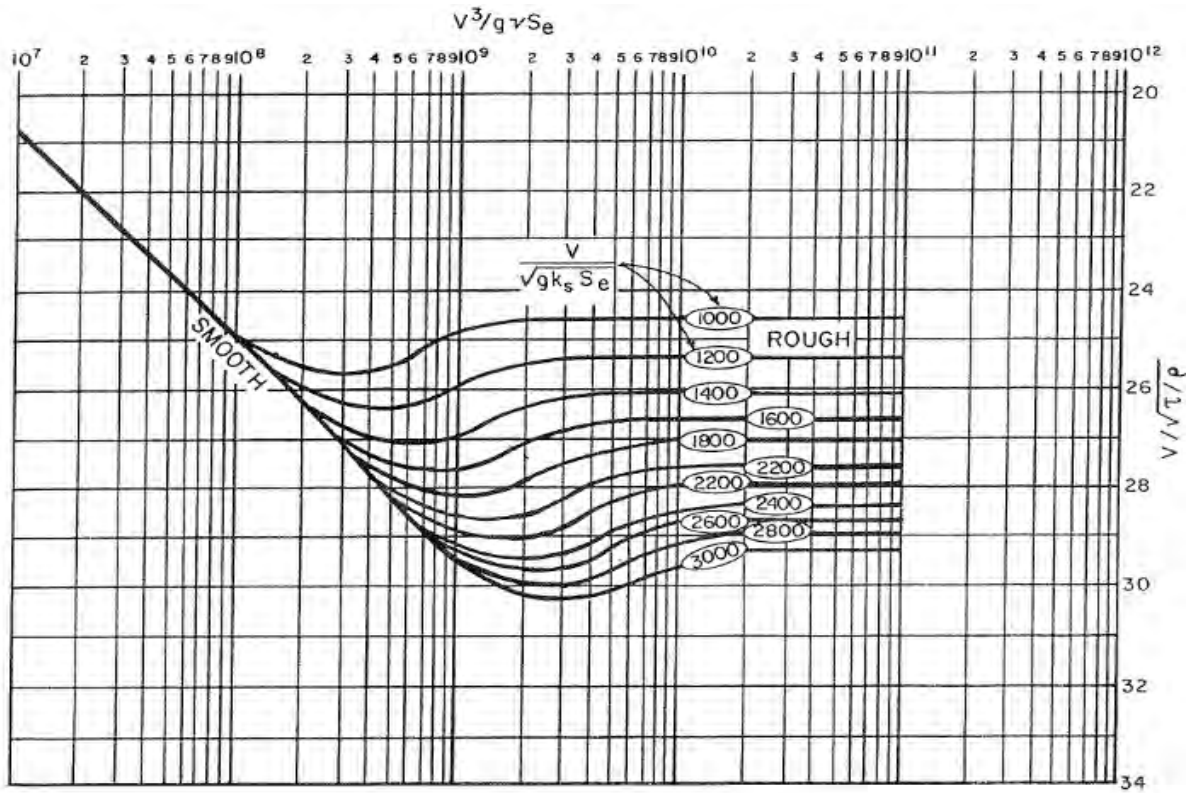
Value 1 6.87E+07

$$V / [(g D_{65} S_e)^{0.5}]$$

Value 2 151.3

Graphic Solution of Reference Tractive Stress





$$V/\sqrt{\tau/\rho}$$

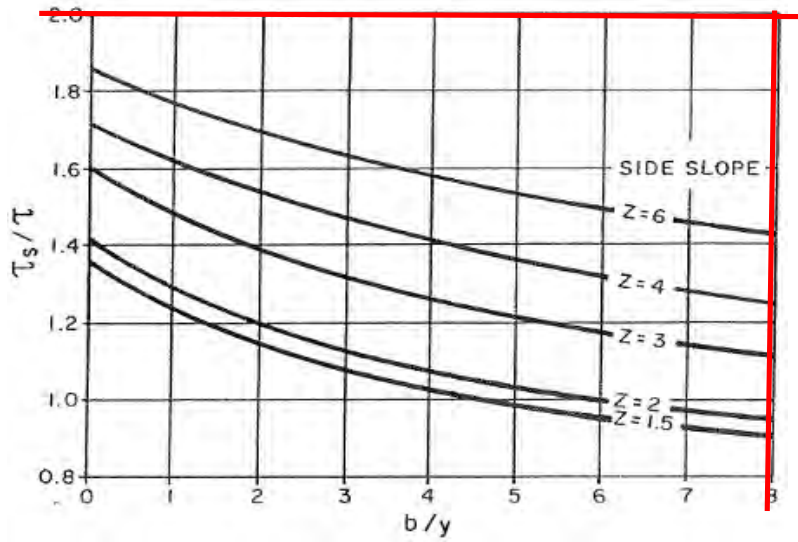
From Graph Above

17.3

Solving the above equation for τ

0.06 lb/ft²

Applied Maximum Tractive Stress, τ_s , on sides of straight trapezoidal channels



Bottom Width/Flow depth
Horizontal/Vertical (Z)

9.13
8.11

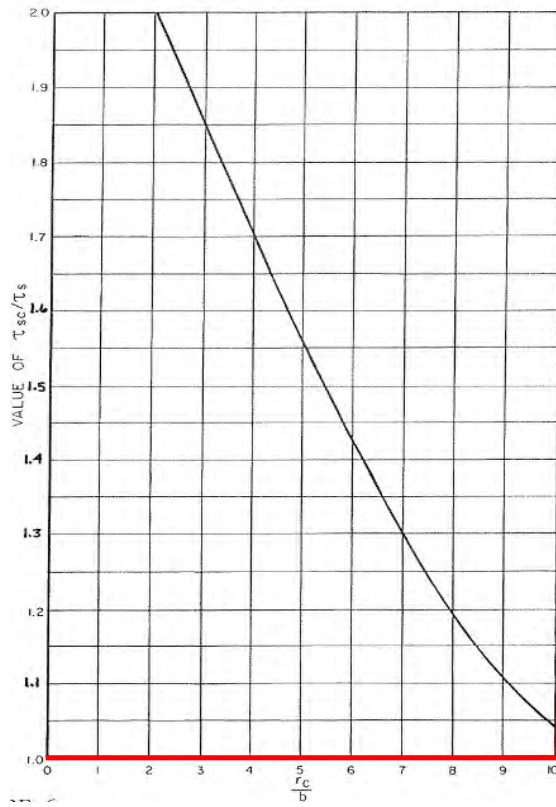
From Graph

2

Solving for τ_s

0.12 lb/ft²

Actual Maximum Tractive Stress, τ_s on sides of trapezoidal channels within a curved reach



Radius of Curvature/Bottom Width

N/A

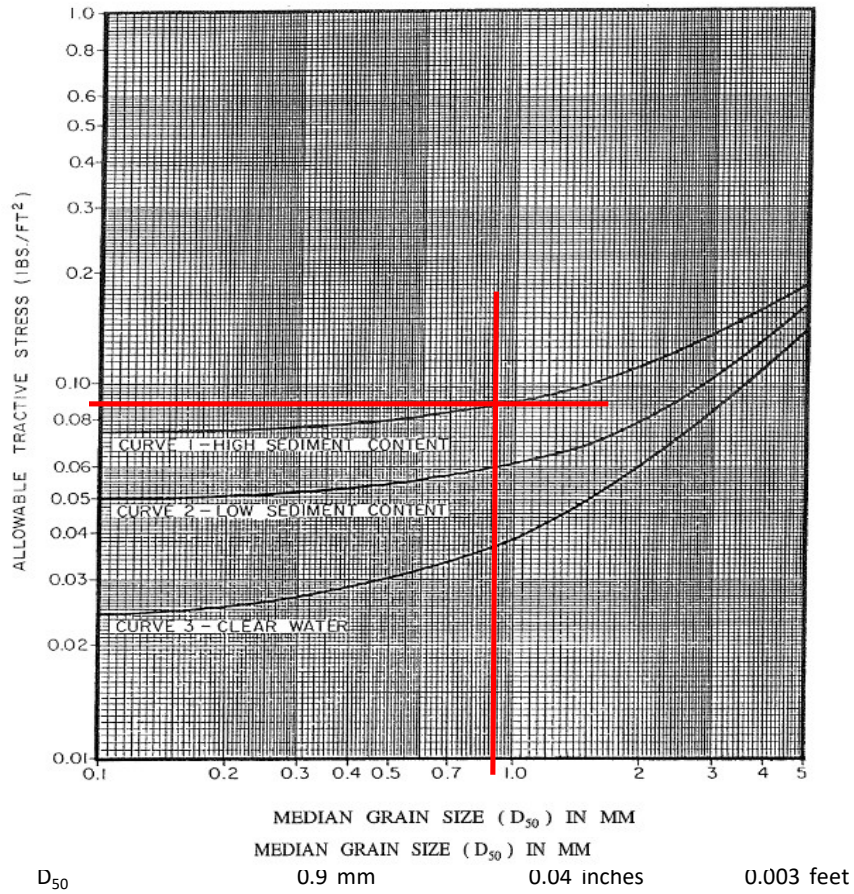
From Graph Above

1.00

Solving for τ_s

0.12 lb/ft²

Maximum Allowable Tractive Stress For Non-Cohesive Soils, $D_{75} < 0.25''$



Allowable Tractive Stress, from graph above 0.092 lb/ft²

Calculated Tractive Stress, τ 0.06 lb/ft²

Since the allowable tractive stress is more than the calculated tractive stress, the channel is not erosive.

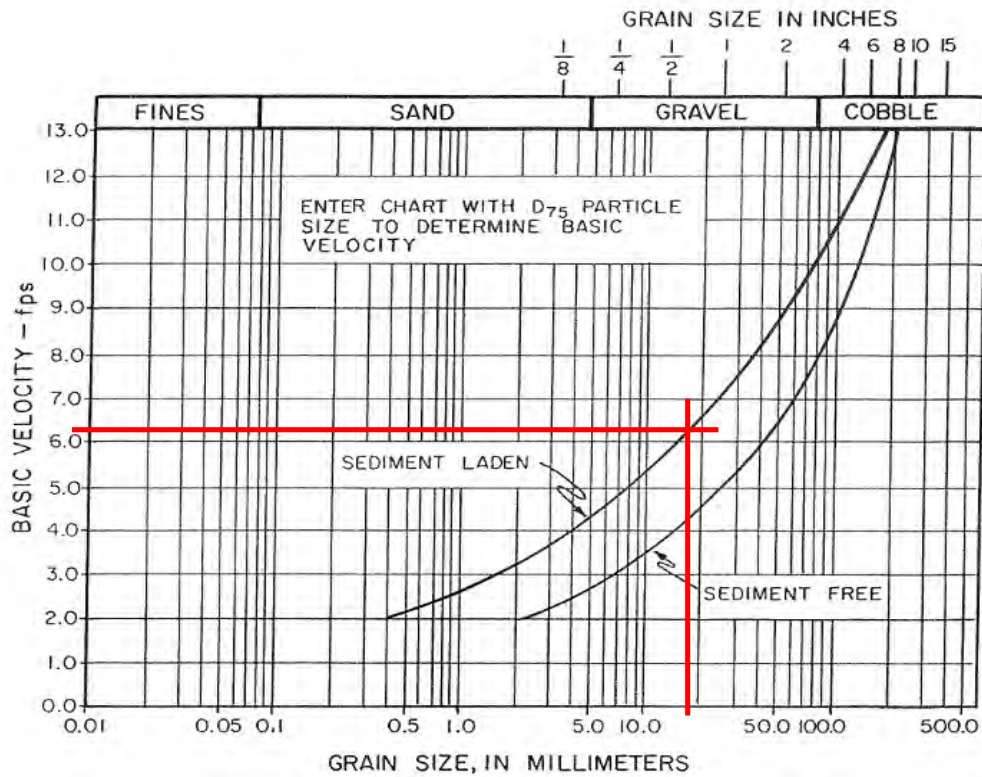
**Lateral Migration Setback Allowance for Riverine Floodplains
Level 2 Analysis**

Cross Section 1223 - General Information

| | | | |
|-------------------------|------------------|--------------|------------|
| Bottom Width (b) | 35.9 feet | | |
| Side Slope (ft) | 30 Horizontal | 3.7 Vertical | |
| Channel Slope (S_e) | 0.001 feet/foot | | |
| Radius of Curvature (r) | 0 feet | | |
| Water Surface Width | 66.29 feet | | |
| Average Manning's n | 0.042 | | |
| | | | |
| Flow Depth (Y) | 3.93 feet | | |
| Flow Velocity (V) | 2.99 feet/second | | |
| | | | |
| D_{75} | 19 mm | 0.75 inches | 0.062 feet |
| D_{65} | 9.1 mm | 0.36 inches | 0.030 feet |
| D_{50} | 5.2 mm | 0.20 inches | 0.017 feet |

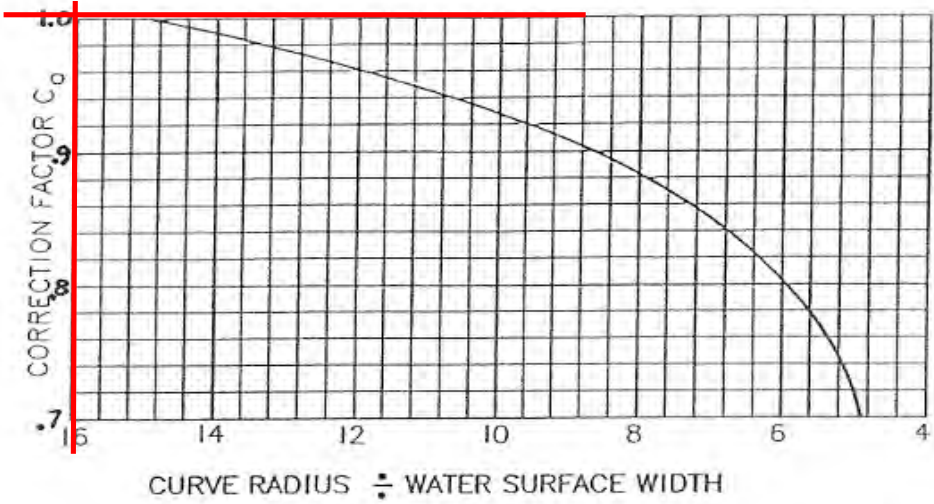
**Allowable Velocity Approach
(Assuming Sediment Laden Flow)**

Base Allowable Velocity for Earth Channels V_b 6.3 feet/sec



Correction Factor C_a For Channel Alignment

1

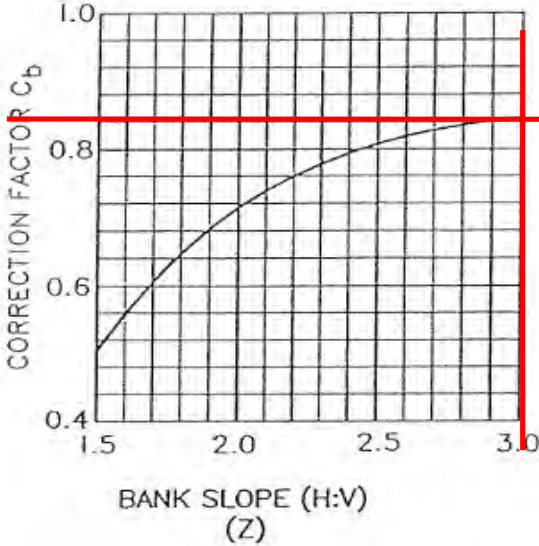


Curve Radius / Water Surface Width

0.0

Correction Factor C_b For Bank Slope

0.84

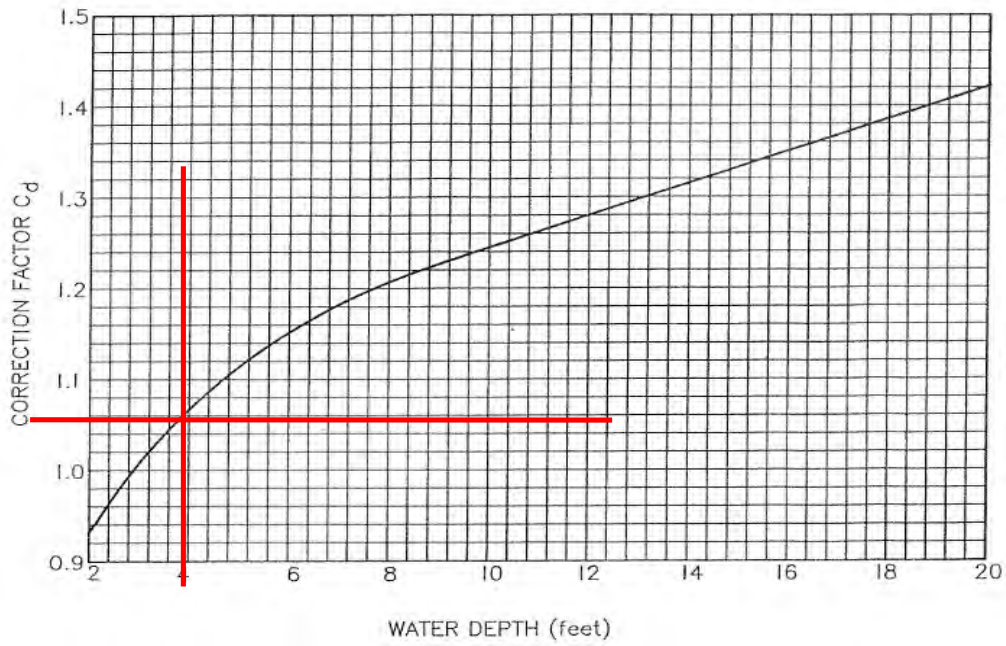


Horizontal/Vertical (Z)

8.11

Correction Factor C_d For Depth of Flow

1.06



Flow Depth (Y)

3.93 feet

Maximum Allowable Velocity

5.61

feet/second

$$V_a = V_b \times C_a \times C_b \times C_d$$

Comparison of Flow Velocity of the Channel to the Maximum Allowable Velocity

Maximum Allowable Velocity

5.61

feet/second

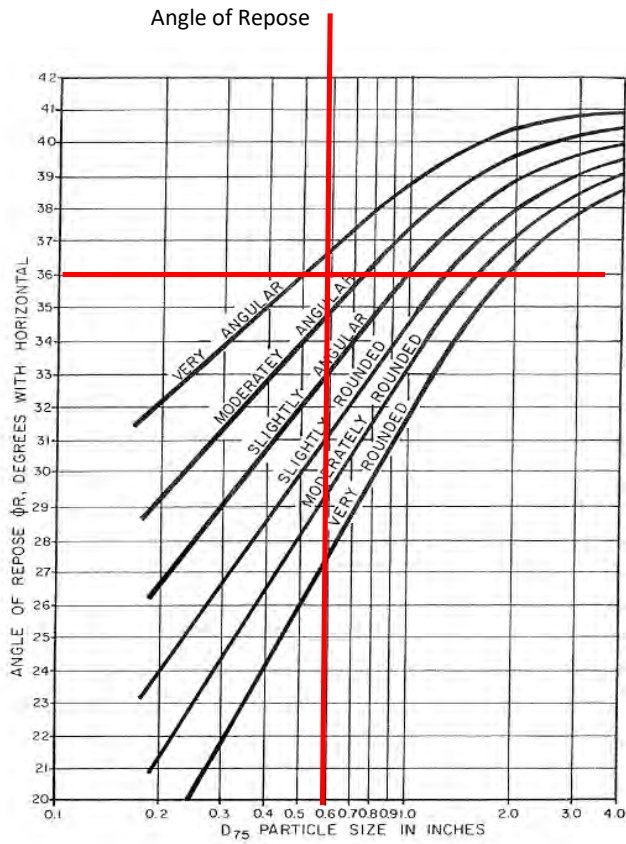
Flow Velocity

2.99

feet/second

Since the computed flow velocity is less than the maximum allowable velocity, erosion is not expected to occur.

Allowable Tractive Stress (τ_{ls})



Moderately Angular
 D_{75} 0.75 inches
 From Chart (ϕ_R) 36 Degrees

Solving for Allowable Tractive Stress

$$0.4 \left[\frac{Z^2 - \cot^2 \phi_R}{1 + Z^2} \right]^{\frac{1}{2}} D_{75}$$

0.290 lbs/ft²

Allowable Tractive Stress, from calculation above 0.290 lb/ft²

Calculated Tractive Stress, τ 0.029 lb/ft²

Since the allowable tractive stress is more than the calculated tractive stress, the channel is not erosive.

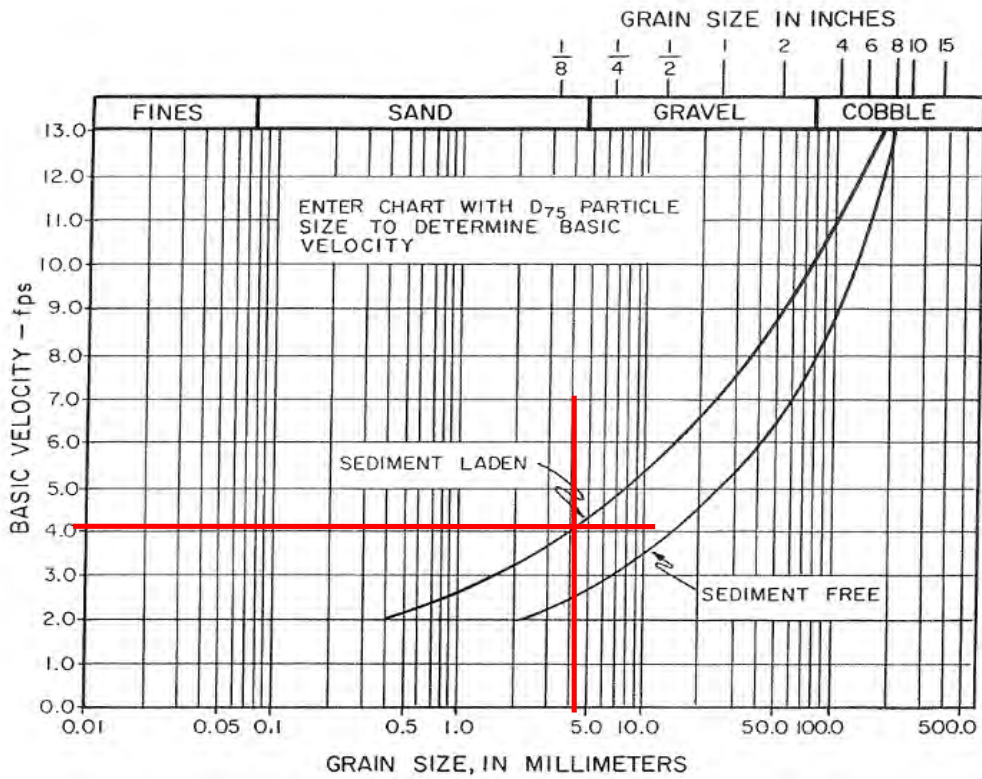
**Lateral Migration Setback Allowance for Riverine Floodplains
Level 2 Analysis**

Cross Section 1319 - General Information

| | | | |
|-------------------------|------------------|---------------|------------|
| Bottom Width (b) | 37 feet | | |
| Side Slope (ft) | 23.5 Horizontal | 4.25 Vertical | |
| Channel Slope (S_e) | 0.003 feet/foot | | |
| Radius of Curvature (r) | 0 feet | | |
| Water Surface Width | 55.14 feet | | |
| Average Manning's n | 0.042 | | |
| | | | |
| Flow Depth (Y) | 3.70 feet | | |
| Flow Velocity (V) | 3.81 feet/second | | |
| | | | |
| D_{75} | 4.4 mm | 0.17 inches | 0.014 feet |
| D_{65} | 3.7 mm | 0.15 inches | 0.012 feet |
| D_{50} | 0.9 mm | 0.04 inches | 0.003 feet |

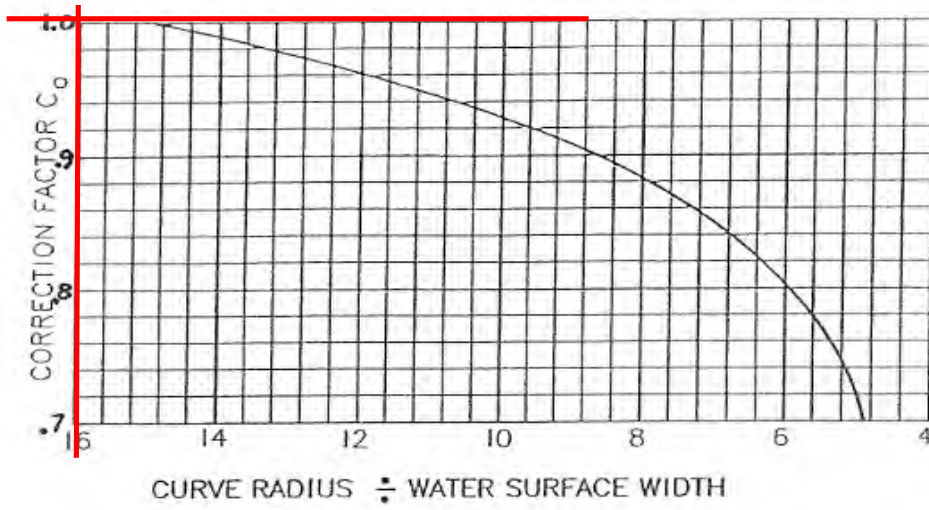
**Allowable Velocity Approach
(Assuming Sediment Laden Flow)**

Base Allowable Velocity for Earth Channels V_b 4.2 feet/sec



Correction Factor C_a For Channel Alignment

1

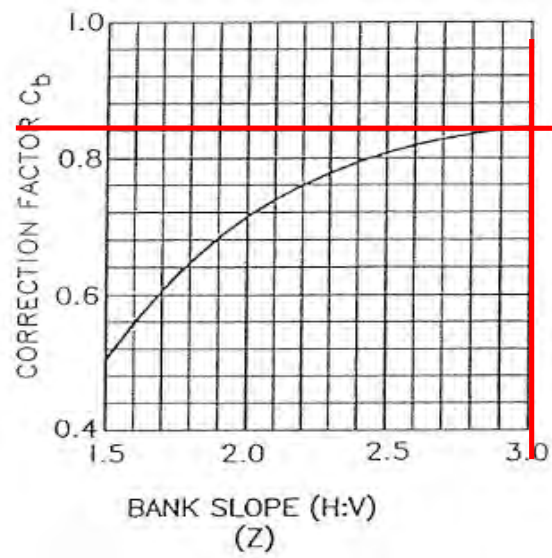


Curve Radius / Water Surface Width

0.0

Correction Factor C_b For Bank Slope

0.84

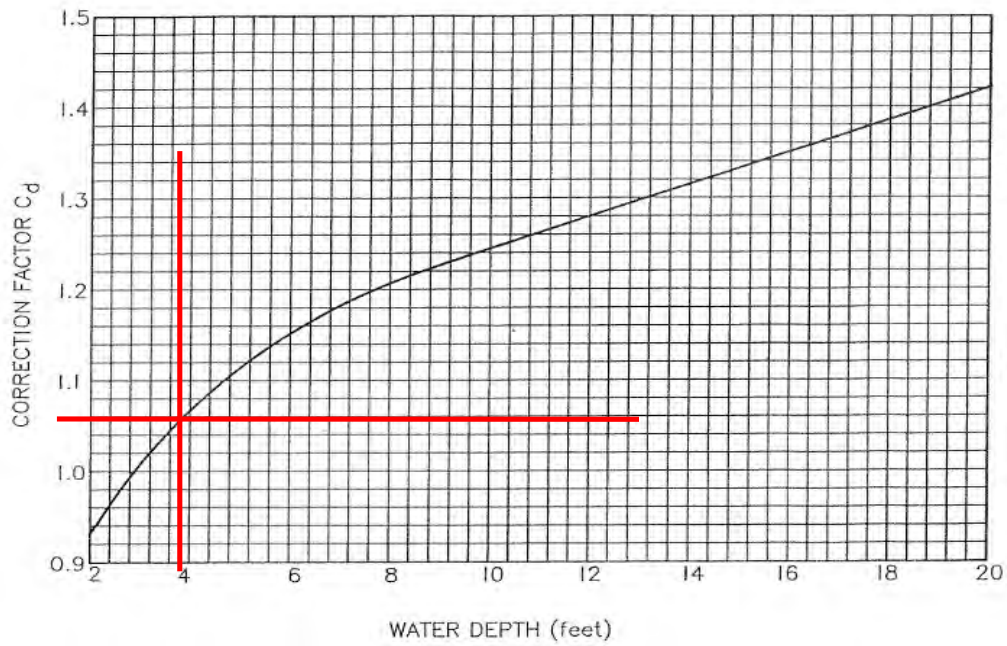


Horizontal/Vertical (Z)

5.53

Correction Factor C_d For Depth of Flow

1.06



Flow Depth (Y)

3.7 feet

Maximum Allowable Velocity

3.74

feet/second

$$V_a = V_b \times C_a \times C_b \times C_d$$

Comparison of Flow Velocity of the Channel to the Maximum Allowable Velocity

Maximum Allowable Velocity

3.74

feet/second

Flow Velocity

3.81

feet/second

Since the computed flow velocity exceeds the maximum allowable velocity, erosion may be expected to occur

**Tractive Stress Analysis
(Assuming Sediment Laden Flow)**

D_{75} 4.4 mm conversion 0.17 inches

Since D_{75} is less or equal to 0.25 inches, case 2 of reference tractive stress method is used.

Assuming a water temperature of 60°F

Kinematic Velocity (ν) 0.0000121 ft² / sec

Density (ρ) 1.94 slugs/ft³

Gravity 32.17 ft/sec²

Finding Values Needed for Graphs

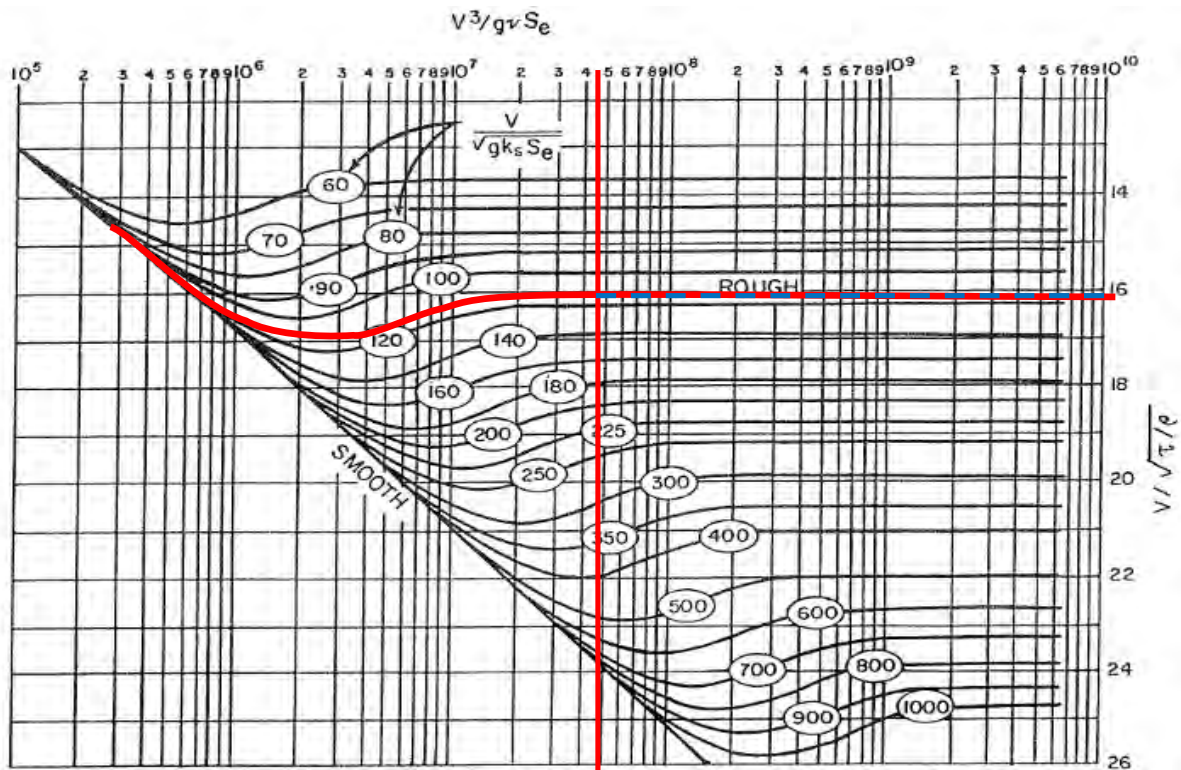
$$V^3 / (g\nu S_e)$$

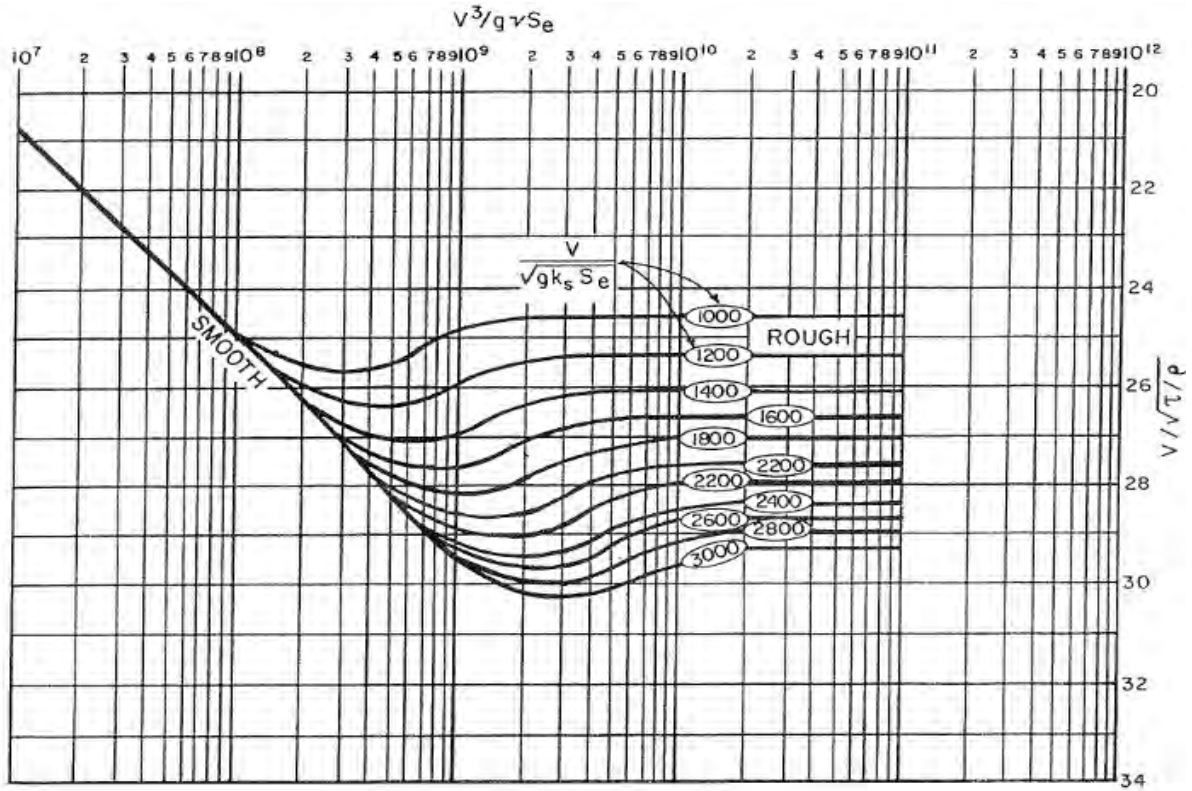
Value 1 4.74E+07

$$V / [(gD_{65} S_e)^{0.5}]$$

Value 2 111.3

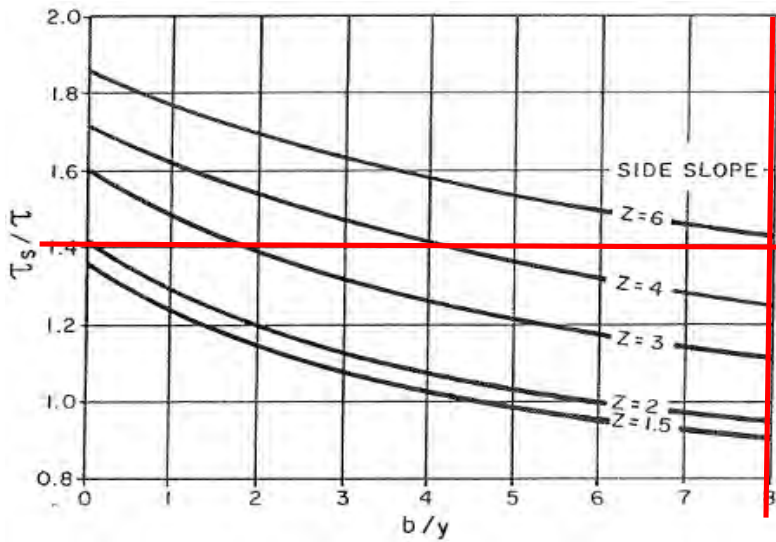
Graphic Solution of Reference Tractive Stress





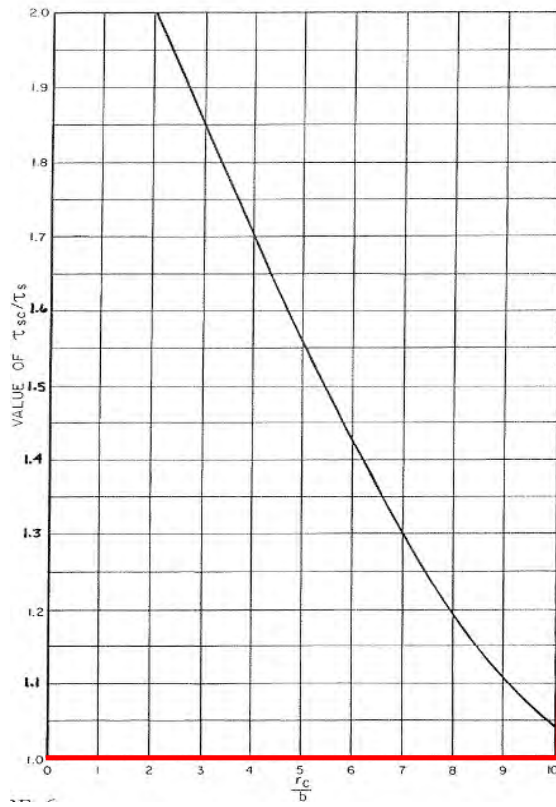
$V/\sqrt{\tau/\rho}$ From Graph Above 16.1
 Solving the above equation for τ 0.11 lb/ft²

Applied Maximum Tractive Stress, τ_s , on sides of straight trapezoidal channels



Bottom Width/Flow depth 10.00
 Horizontal/Vertical (Z) 5.53
 From Graph 1.4
 Solving for τ_s 0.15 lb/ft²

Actual Maximum Tractive Stress, τ_s on sides of trapezoidal channels within a curved reach



Radius of Curvature/Bottom Width

N/A

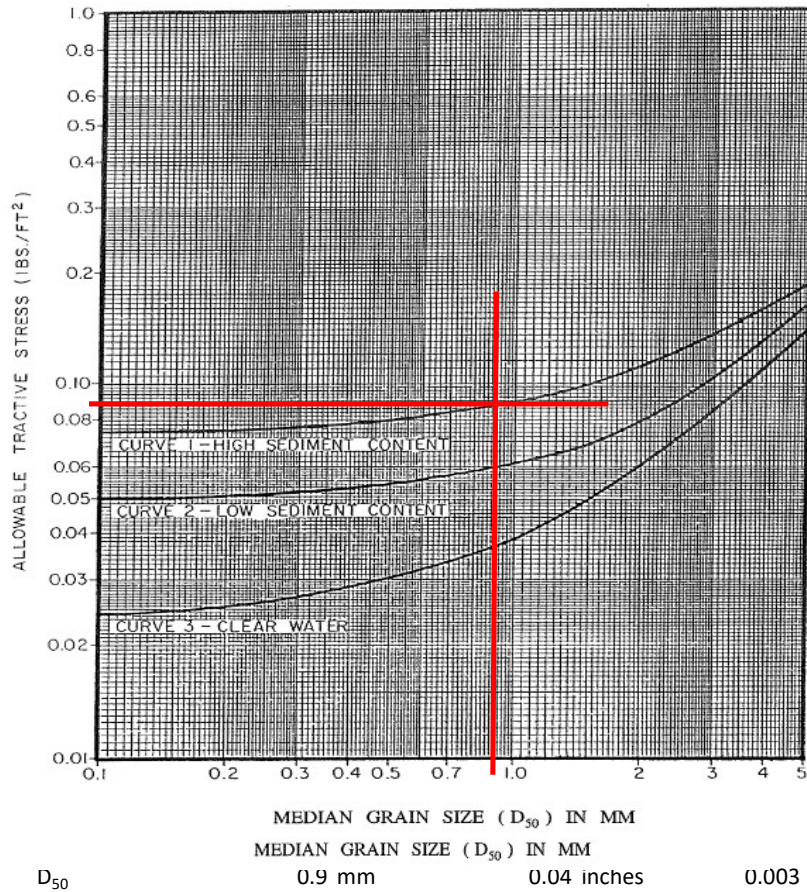
From Graph Above

1.00

Solving for τ_s

0.15 lb/ft²

Maximum Allowable Tractive Stress For Non-Cohesive Soils, $D_{75} < 0.25''$



Allowable Tractive Stress, from graph above 0.092 lb/ft²

Calculated Tractive Stress, τ 0.109 lb/ft²

Since the allowable tractive stress is less than the calculated tractive stress, the channel is erosive.

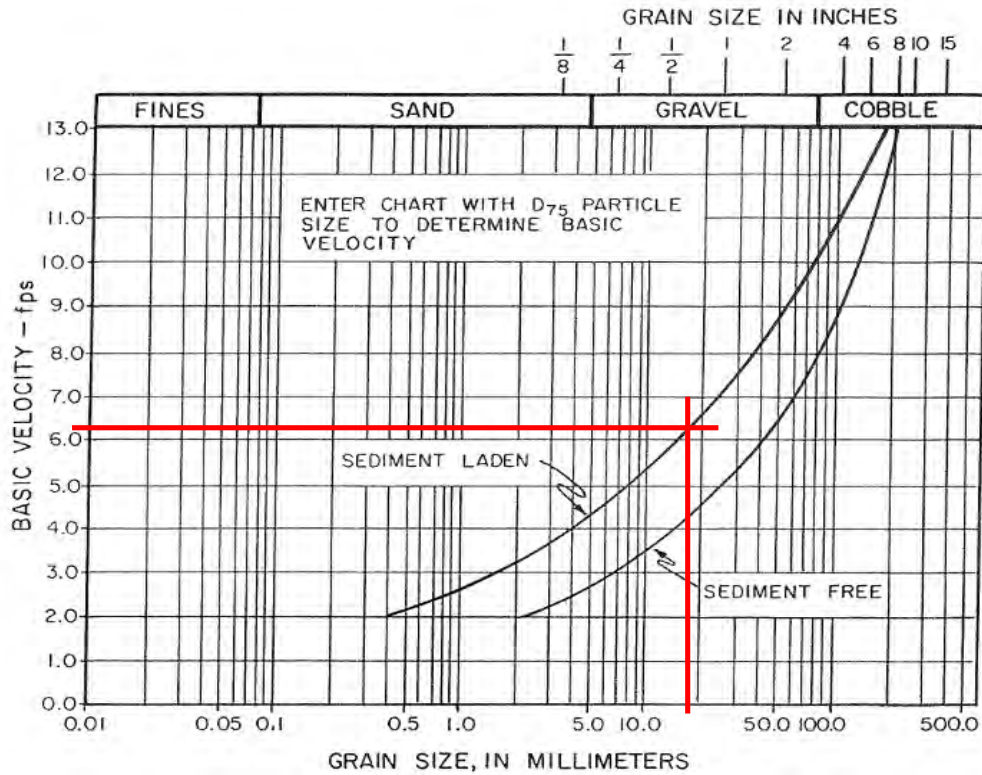
**Lateral Migration Setback Allowance for Riverine Floodplains
Level 2 Analysis**

Cross Section 1319 - General Information

| | | | |
|-------------------------|------------------|---------------|------------|
| Bottom Width (b) | 37 feet | | |
| Side Slope (ft) | 23.5 Horizontal | 4.25 Vertical | |
| Channel Slope (S_e) | 0.003 feet/foot | | |
| Radius of Curvature (r) | 0 feet | | |
| Water Surface Width | 55.14 feet | | |
| Average Manning's n | 0.042 | | |
| | | | |
| Flow Depth (Y) | 3.70 feet | | |
| Flow Velocity (V) | 3.81 feet/second | | |
| | | | |
| D_{75} | 19 mm | 0.75 inches | 0.062 feet |
| D_{65} | 9.1 mm | 0.36 inches | 0.030 feet |
| D_{50} | 5.2 mm | 0.20 inches | 0.017 feet |

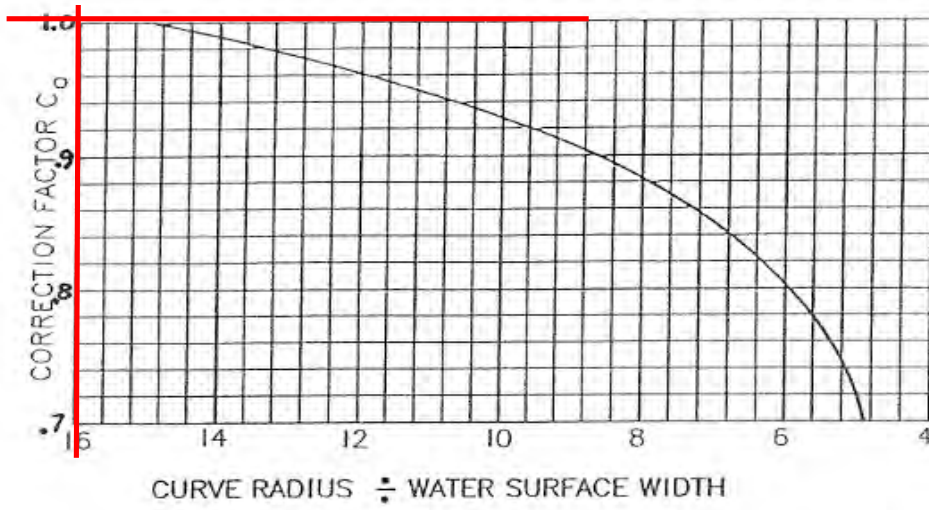
**Allowable Velocity Approach
(Assuming Sediment Laden Flow)**

Base Allowable Velocity for Earth Channels V_b 6.3 feet/sec



Correction Factor C_a For Channel Alignment

1

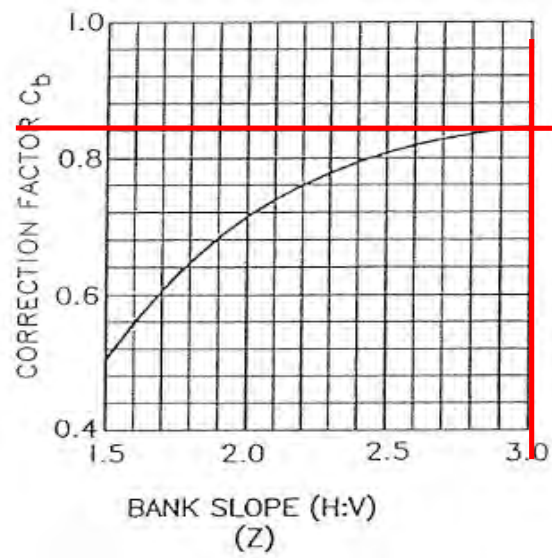


Curve Radius / Water Surface Width

0.0

Correction Factor C_b For Bank Slope

0.84

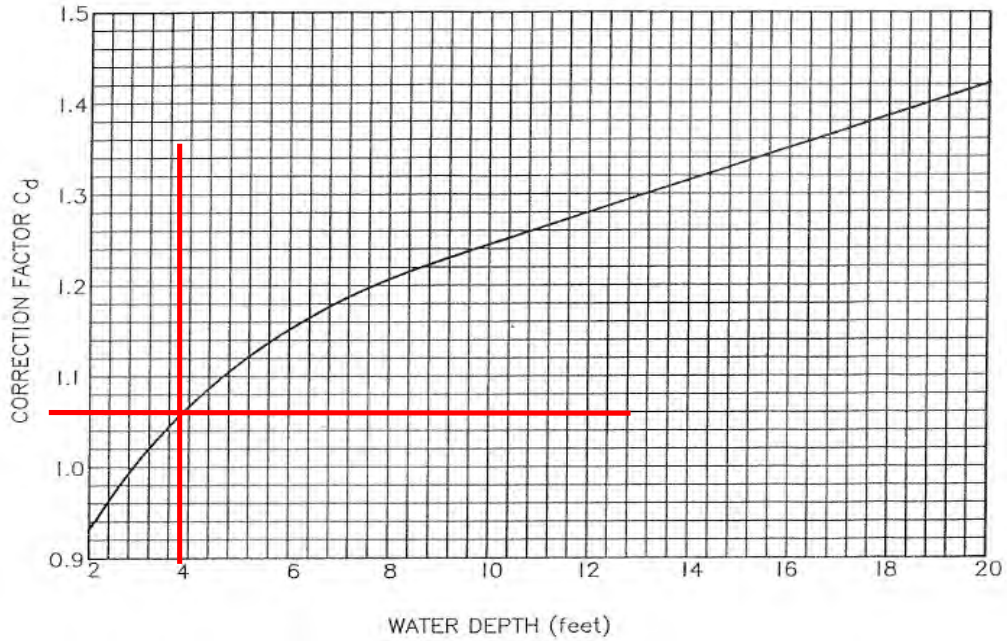


Horizontal/Vertical (Z)

5.53

Correction Factor C_d For Depth of Flow

1.06



Flow Depth (Y)

3.7 feet

Maximum Allowable Velocity

5.61

feet/second

$$V_a = V_b \times C_a \times C_b \times C_d$$

Comparison of Flow Velocity of the Channel to the Maximum Allowable Velocity

Maximum Allowable Velocity

5.61

feet/second

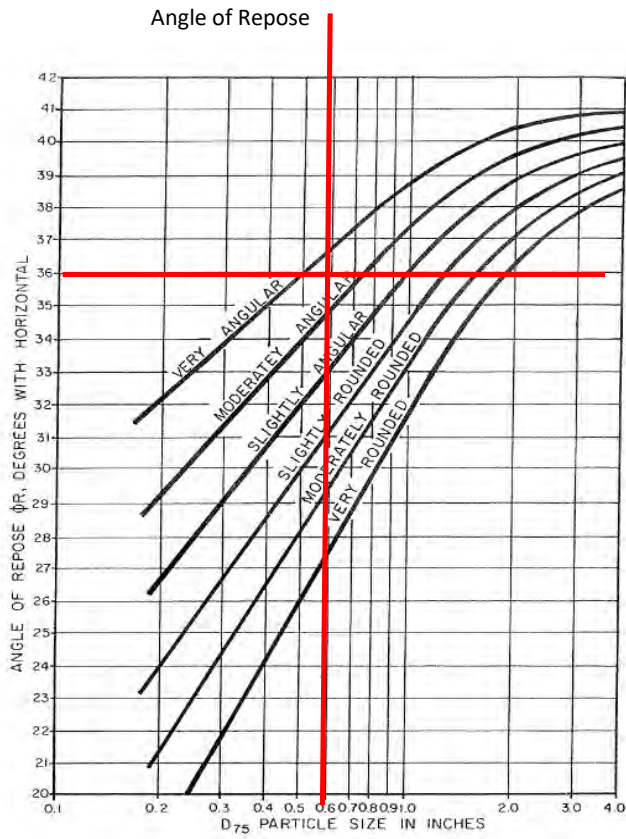
Flow Velocity

3.81

feet/second

Since the computed flow velocity is less than the maximum allowable velocity, erosion is not expected to occur.

Allowable Tractive Stress (τ_s)



Moderately Angular
 D_{75} 0.75 inches
 From Chart (ϕ_R) 36 Degrees

Solving for Allowable Tractive Stress

$$0.4 \left[\frac{Z^2 - \cot^2 \phi_R}{1 + Z^2} \right]^{\frac{1}{2}} D_{75}$$

0.280 lbs/ft²

Allowable Tractive Stress, from calculation above 0.280 lb/ft²

Calculated Tractive Stress, τ 0.081 lb/ft²

Since the allowable tractive stress is more than the calculated tractive stress, the channel is not erosive.

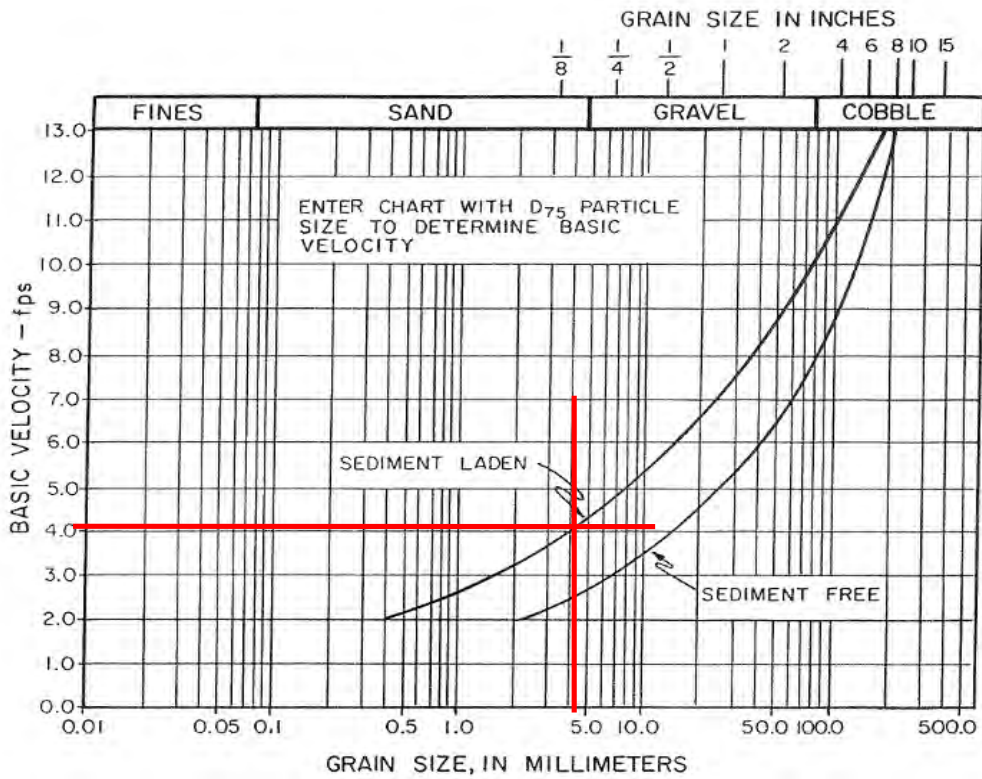
**Lateral Migration Setback Allowance for Riverine Floodplains
Level 2 Analysis**

Cross Section 1422 - General Information

| | | | |
|-------------------------|------------------|--------------|------------|
| Bottom Width (b) | 25 feet | | |
| Side Slope (ft) | 23 Horizontal | 4.7 Vertical | |
| Channel Slope (S_e) | 0.004 feet/foot | | |
| Radius of Curvature (r) | 0 feet | | |
| Water Surface Width | 45.11 feet | | |
| Average Manning's n | 0.042 | | |
| | | | |
| Flow Depth (Y) | 4.05 feet | | |
| Flow Velocity (V) | 4.37 feet/second | | |
| | | | |
| D_{75} | 4.4 mm | 0.17 inches | 0.014 feet |
| D_{65} | 3.7 mm | 0.15 inches | 0.012 feet |
| D_{50} | 0.9 mm | 0.04 inches | 0.003 feet |

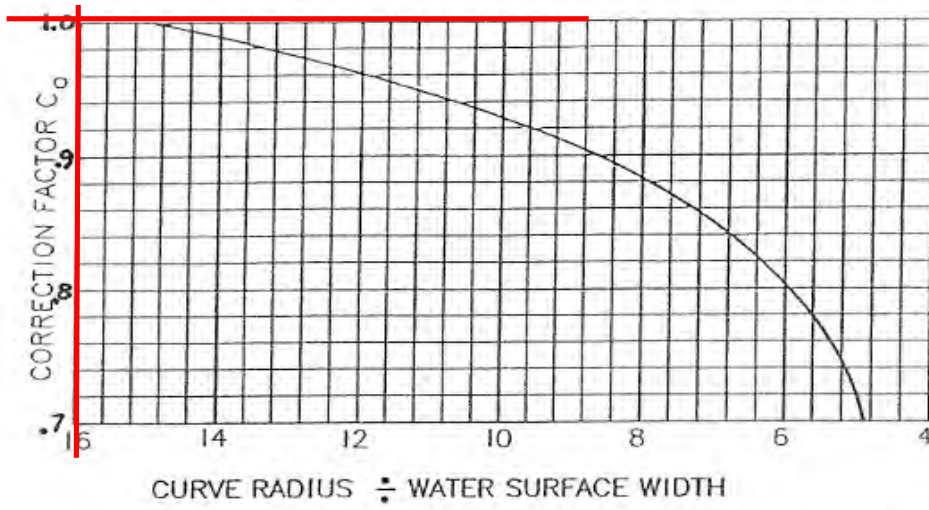
**Allowable Velocity Approach
(Assuming Sediment Laden Flow)**

Base Allowable Velocity for Earth Channels V_b 4.2 feet/sec



Correction Factor C_a For Channel Alignment

1

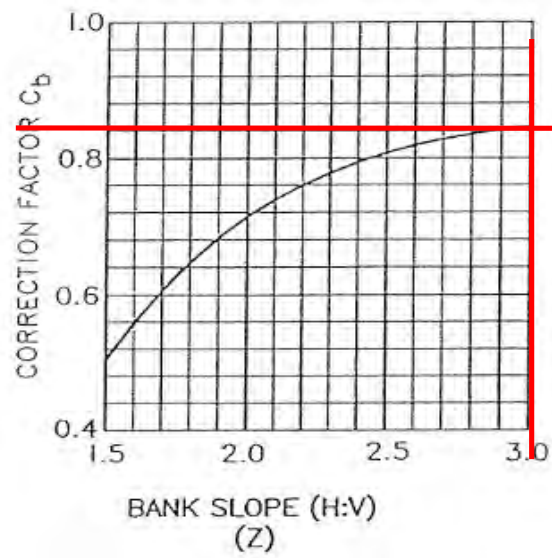


Curve Radius / Water Surface Width

0.0

Correction Factor C_b For Bank Slope

0.84

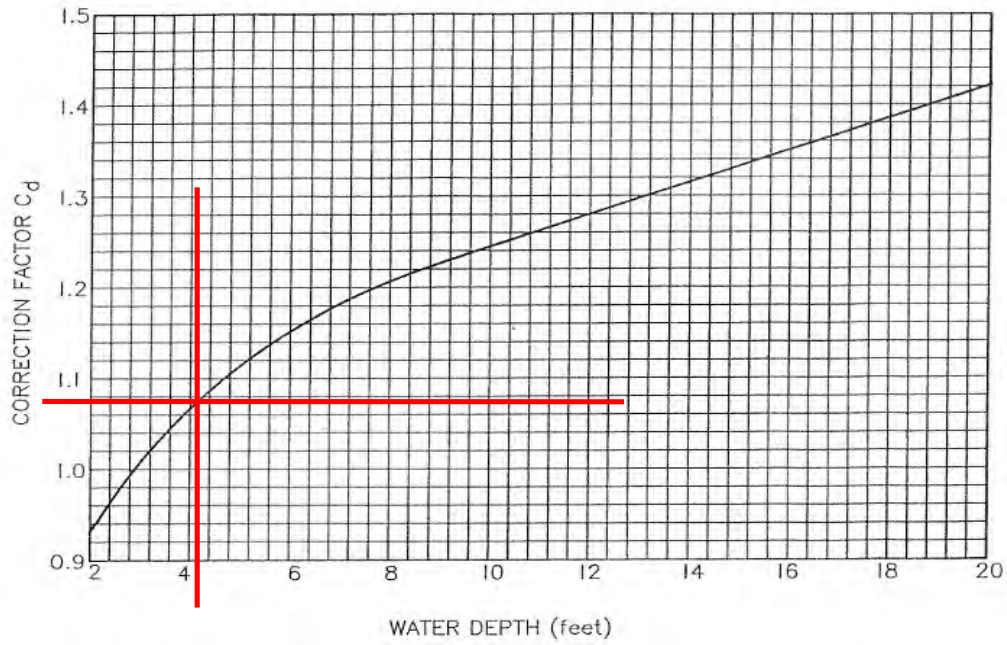


Horizontal/Vertical (Z)

4.89

Correction Factor C_d For Depth of Flow

1.08



Flow Depth (Y)

4.05 feet

Maximum Allowable Velocity

3.81

feet/second

$$V_a = V_b \times C_a \times C_b \times C_d$$

Comparison of Flow Velocity of the Channel to the Maximum Allowable Velocity

Maximum Allowable Velocity

3.81

feet/second

Flow Velocity

4.37

feet/second

Since the computed flow velocity exceeds the maximum allowable velocity, erosion may be expected to occur

**Tractive Stress Analysis
(Assuming Sediment Laden Flow)**

D_{75} 4.4 mm conversion 0.17 inches

Since D_{75} is less or equal to 0.25 inches, case 2 of reference tractive stress method is used.

Assuming a water temperature of 60°F

Kinematic Velocity (ν) 0.0000121 ft² / sec
 Density (ρ) 1.94 slugs/ft³
 Gravity 32.17 ft/sec²

Finding Values Needed for Graphs

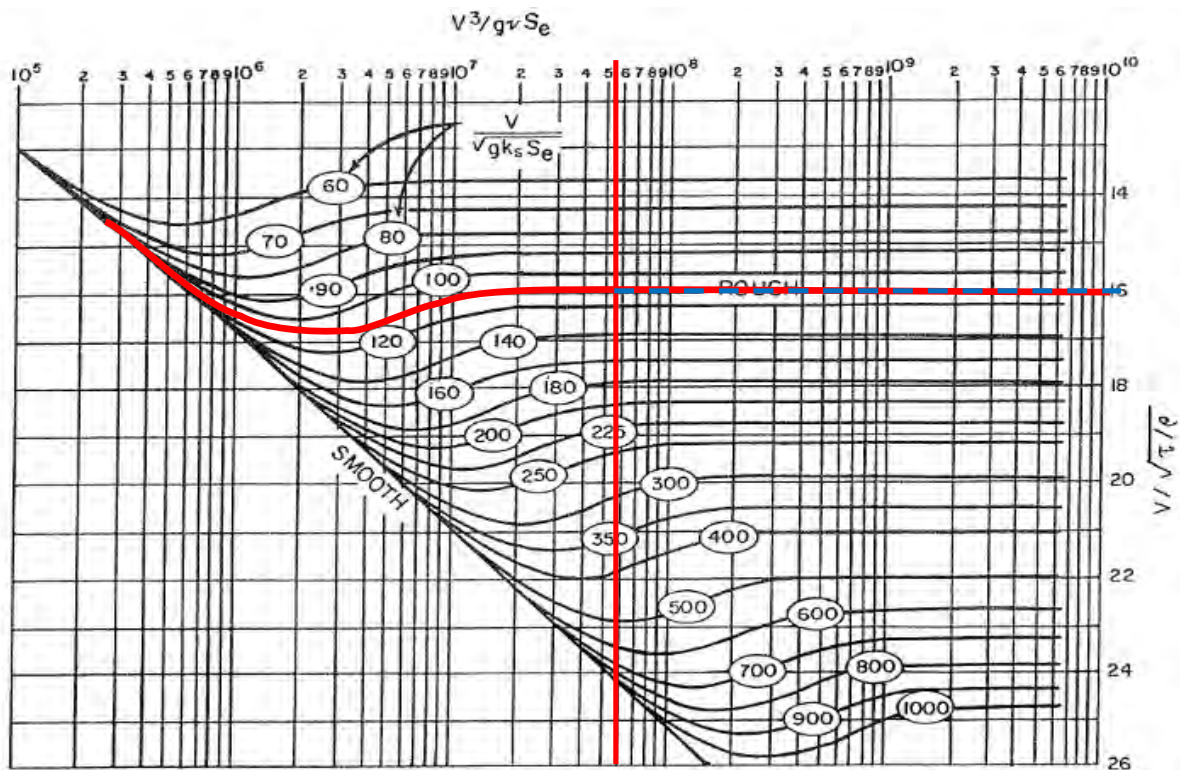
$$V^3 / (g\nu S_e)$$

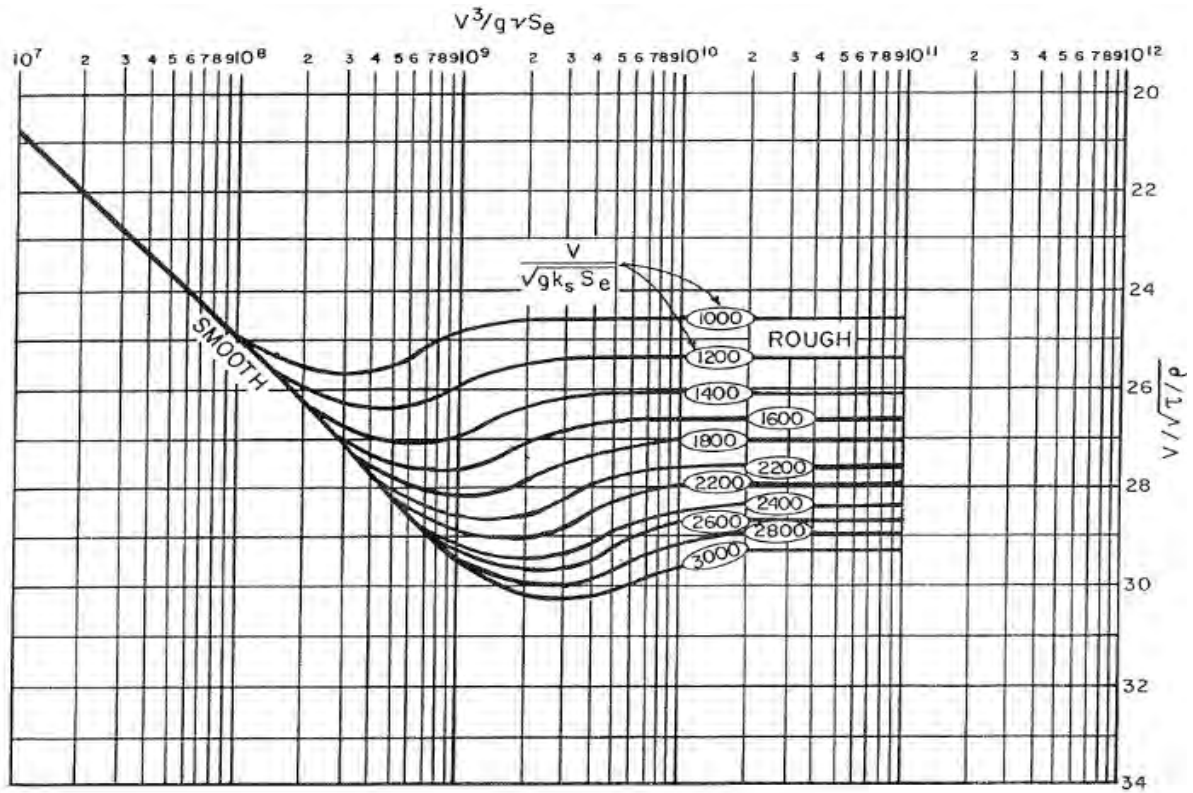
Value 1 5.36E+07

$$V / [(gD_{65} S_e)^{0.5}]$$

Value 2 110.6

Graphic Solution of Reference Tractive Stress





$$V/\sqrt{\tau/\rho}$$

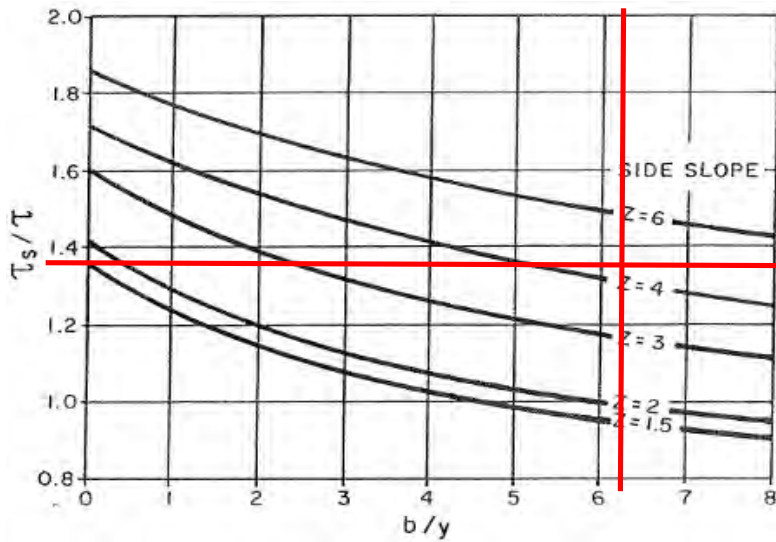
From Graph Above

16

Solving the above equation for τ

0.14 lb/ft²

Applied Maximum Tractive Stress, τ_s , on sides of straight trapezoidal channels



Bottom Width/Flow depth
Horizontal/Vertical (Z)

6.17
4.89

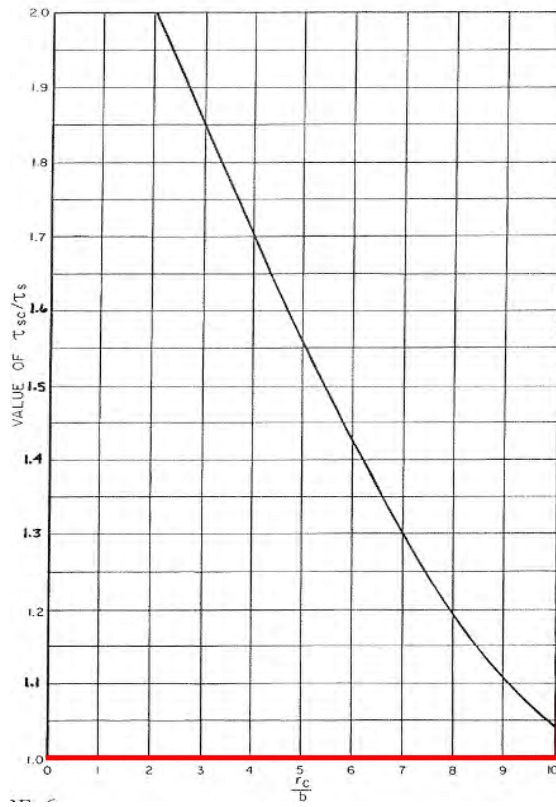
From Graph

1.38

Solving for τ_s

0.20 lb/ft²

Actual Maximum Tractive Stress, τ_s on sides of trapezoidal channels within a curved reach



Radius of Curvature/Bottom Width

N/A

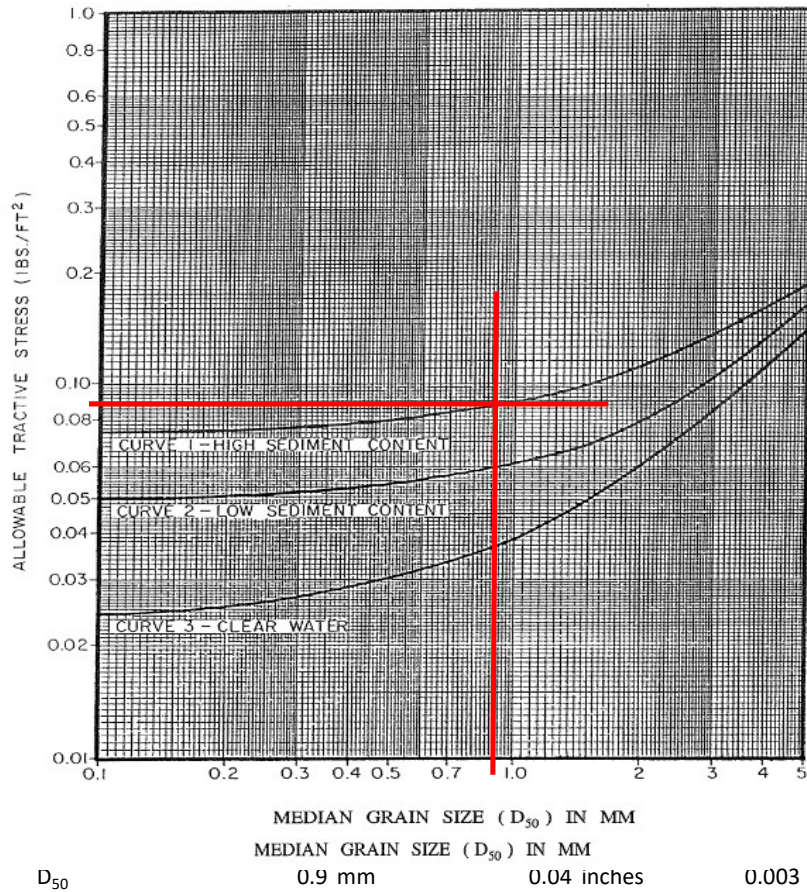
From Graph Above

1.00

Solving for τ_s

0.20 lb/ft²

Maximum Allowable Tractive Stress For Non-Cohesive Soils, $D_{75} < 0.25''$



Allowable Tractive Stress, from graph above 0.092 lb/ft²

Calculated Tractive Stress, τ 0.14 lb/ft²

Since the allowable tractive stress is less than the calculated tractive stress, the channel is erosive.

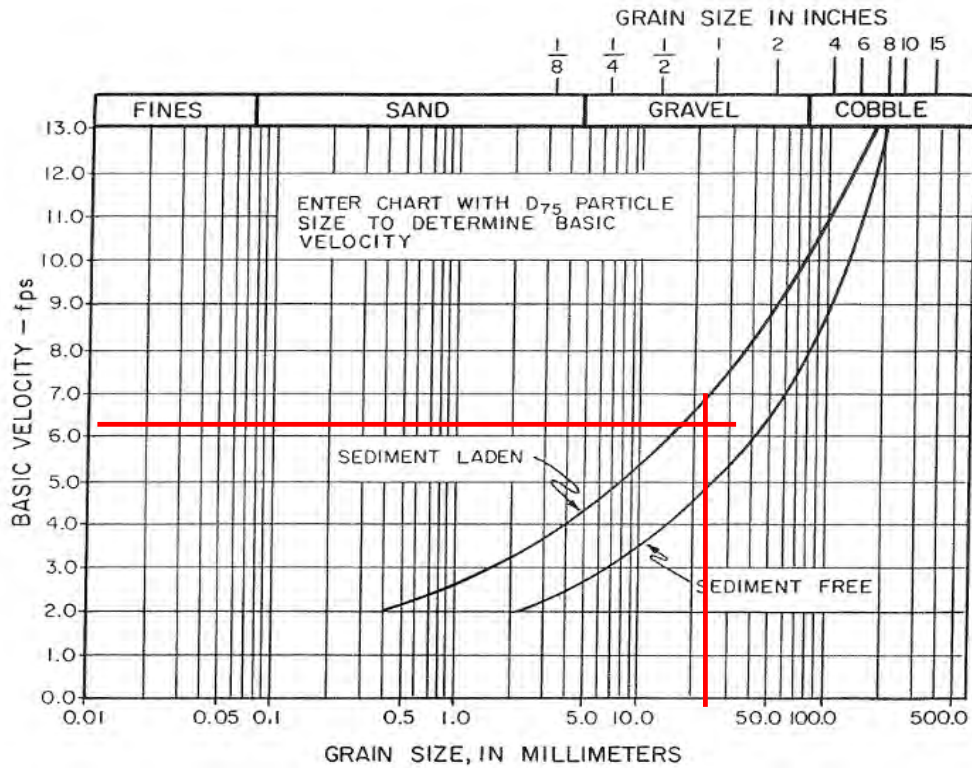
**Lateral Migration Setback Allowance for Riverine Floodplains
Level 2 Analysis**

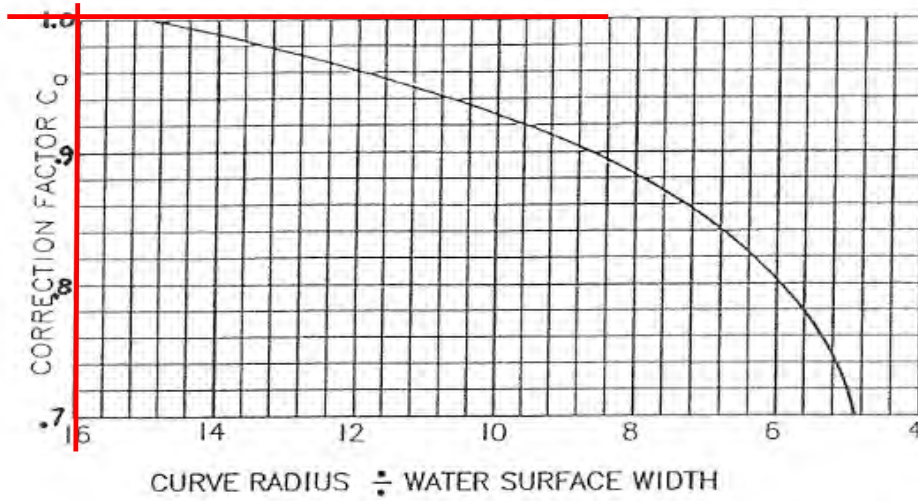
Cross Section 1422 - General Information

| | | | |
|-------------------------|------------------|--------------|------------|
| Bottom Width (b) | 25 feet | | |
| Side Slope (ft) | 23 Horizontal | 4.7 Vertical | |
| Channel Slope (S_c) | 0.004 feet/foot | | |
| Radius of Curvature (r) | 0 feet | | |
| Water Surface Width | 45.11 feet | | |
| Average Manning's n | 0.042 | | |
| | | | |
| Flow Depth (Y) | 4.05 feet | | |
| Flow Velocity (V) | 4.37 feet/second | | |
| | | | |
| D_{75} | 19 mm | 0.75 inches | 0.062 feet |
| D_{65} | 9.1 mm | 0.36 inches | 0.030 feet |
| D_{50} | 5.2 mm | 0.20 inches | 0.017 feet |

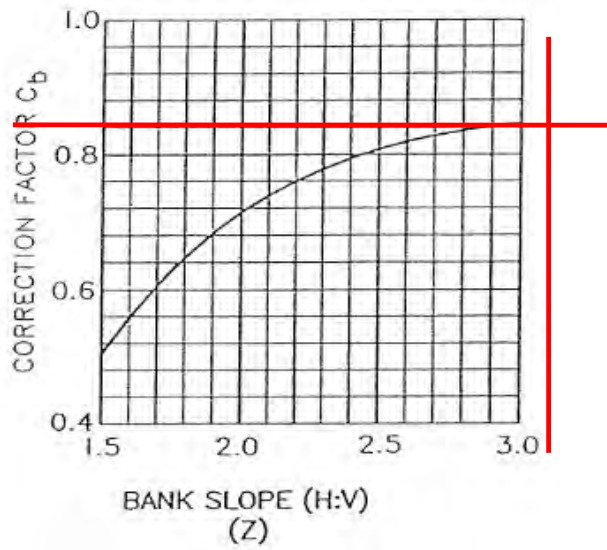
**Allowable Velocity Approach
(Assuming Sediment Laden Flow)**

Base Allowable Velocity for Earth Channels V_b 6.3 feet/sec





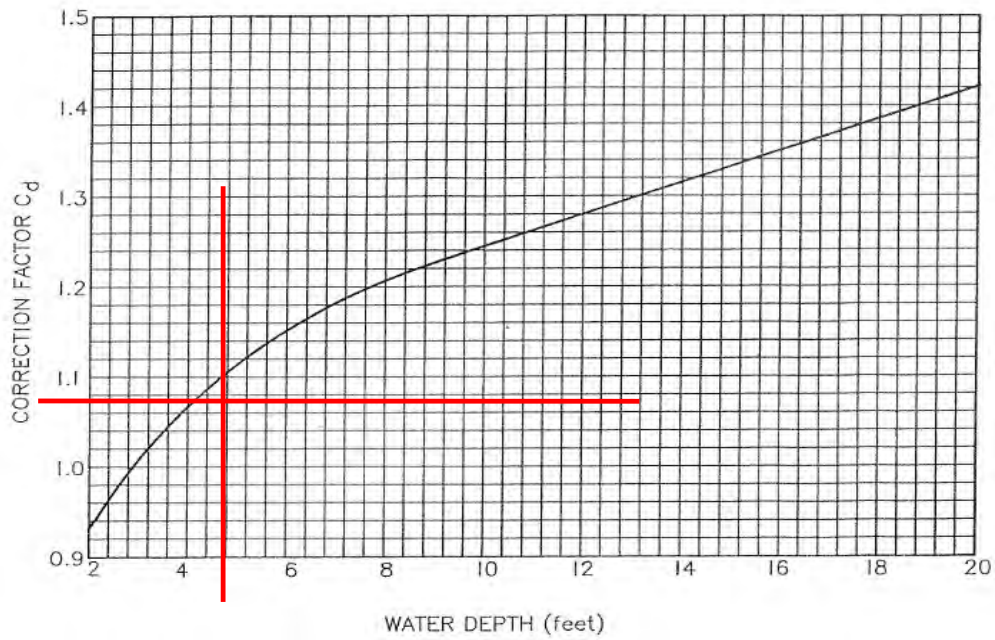
Curve Radius / Water Surface Width 0.0



Horizontal/Vertical (Z) 4.89

Correction Factor C_d For Depth of Flow

1.08



Flow Depth (Y)

4.05 feet

Maximum Allowable Velocity

5.72

feet/second

$$V_a = V_b \times C_a \times C_b \times C_d$$

Comparison of Flow Velocity of the Channel to the Maximum Allowable Velocity

Maximum Allowable Velocity

5.72

feet/second

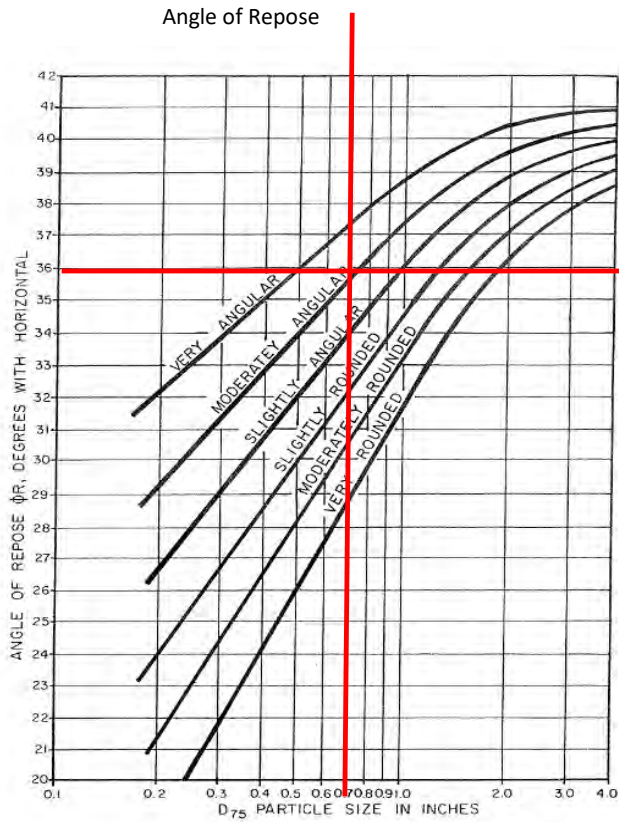
Flow Velocity

4.37

feet/second

Since the computed flow velocity is less than the maximum allowable velocity, erosion is not expected to occur.

Allowable Tractive Stress (τ_s)



Moderately Angular
 D_{75} 0.75 inches
 From Chart (ϕR) 36 Degrees

Solving for Allowable Tractive Stress

$$0.4 \left[\frac{Z^2 - \cot^2 \phi R}{1 + Z^2} \right]^{\frac{1}{2}} D_{75}$$

0.275 lbs/ft²

Allowable Tractive Stress, from calculation above 0.275 lb/ft²

Calculated Tractive Stress, τ 0.12 lb/ft²

Since the allowable tractive stress is more than the calculated tractive stress, the channel is not erosive.

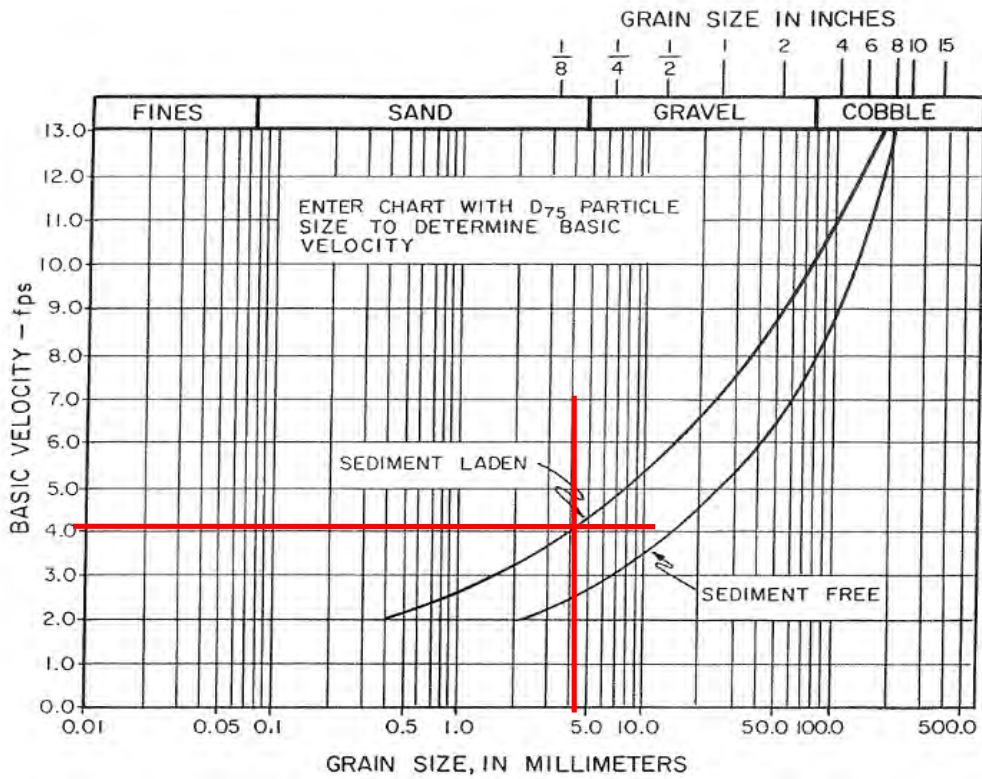
**Lateral Migration Setback Allowance for Riverine Floodplains
Level 2 Analysis**

Cross Section 1496 - General Information

| | | | |
|-------------------------|------------------|--------------|------------|
| Bottom Width (b) | 24.9 feet | | |
| Side Slope (ft) | 15.5 Horizontal | 2.5 Vertical | |
| Channel Slope (S_e) | 0.004 feet/foot | | |
| Radius of Curvature (r) | 0 feet | | |
| Water Surface Width | 42.38 feet | | |
| Average Manning's n | 0.034 | | |
| | | | |
| Flow Depth (Y) | 4.29 feet | | |
| Flow Velocity (V) | 5.01 feet/second | | |
| | | | |
| D_{75} | 4.4 mm | 0.17 inches | 0.014 feet |
| D_{65} | 3.7 mm | 0.15 inches | 0.012 feet |
| D_{50} | 0.9 mm | 0.04 inches | 0.003 feet |

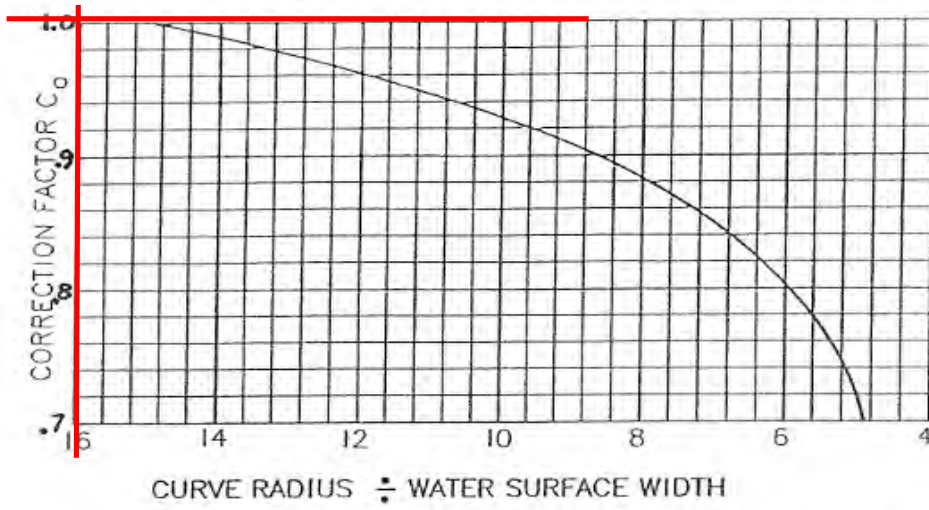
**Allowable Velocity Approach
(Assuming Sediment Laden Flow)**

Base Allowable Velocity for Earth Channels V_b 4.2 feet/sec



Correction Factor C_a For Channel Alignment

1

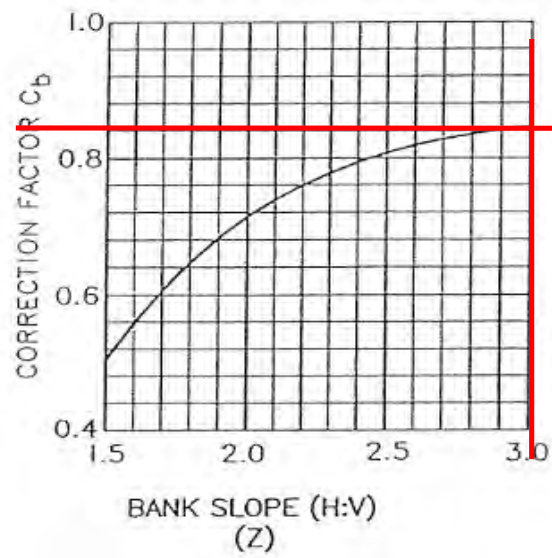


Curve Radius / Water Surface Width

0.0

Correction Factor C_b For Bank Slope

0.84

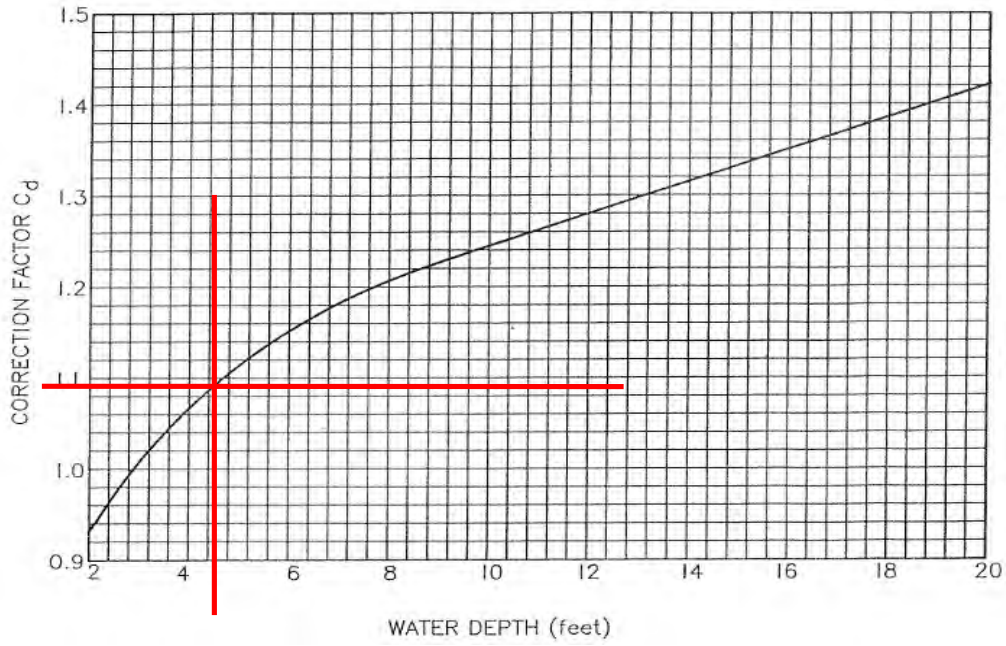


Horizontal/Vertical (Z)

6.20

Correction Factor C_d For Depth of Flow

1.09



Flow Depth (Y)

4.29 feet

Maximum Allowable Velocity

3.85

feet/second

$$V_a = V_b \times C_a \times C_b \times C_d$$

Comparison of Flow Velocity of the Channel to the Maximum Allowable Velocity

Maximum Allowable Velocity

3.85

feet/second

Flow Velocity

5.01

feet/second

Since the computed flow velocity exceeds the maximum allowable velocity, erosion may be expected to occur

**Tractive Stress Analysis
(Assuming Sediment Laden Flow)**

D_{75} 4.4 mm conversion 0.17 inches

Since D_{75} is less or equal to 0.25 inches, case 2 of reference tractive stress method is used.

Assuming a water temperature of 60°F

Kinematic Velocity (v) 0.0000121 ft² / sec
 Density (ρ) 1.94 slugs/ft³
 Gravity 32.17 ft/sec²

Finding Values Needed for Graphs

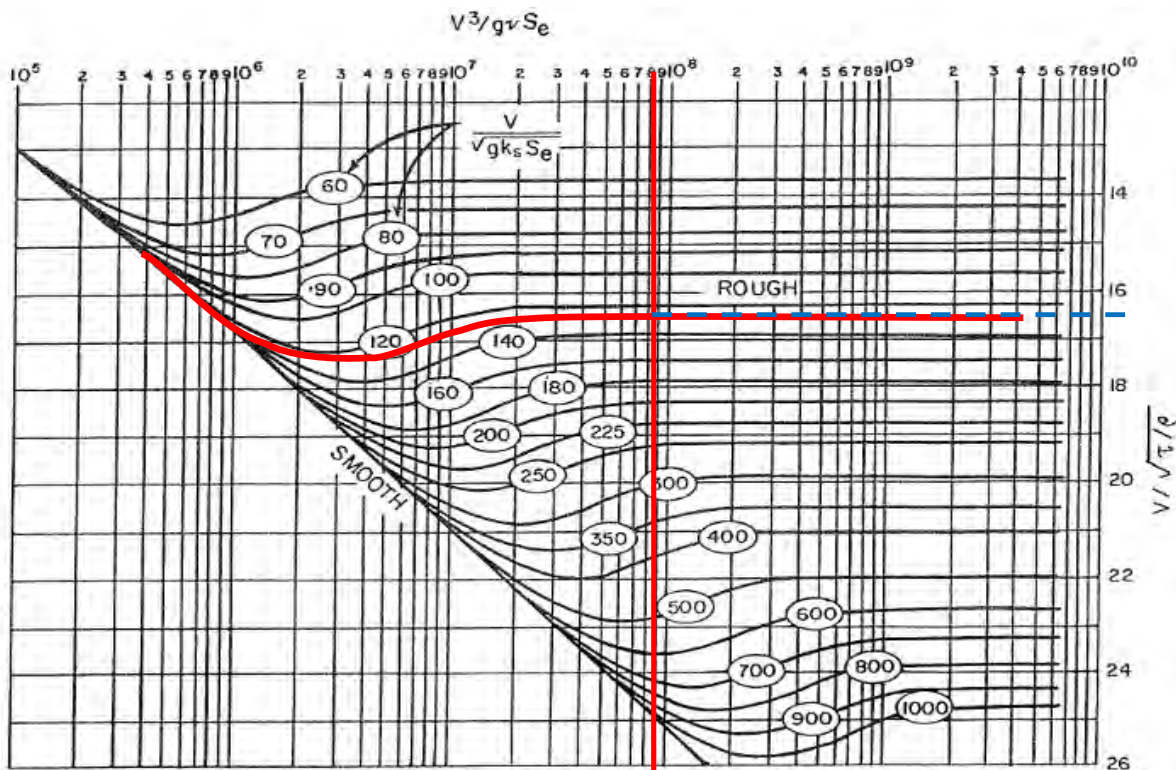
$$V^3 / (g v S_e)$$

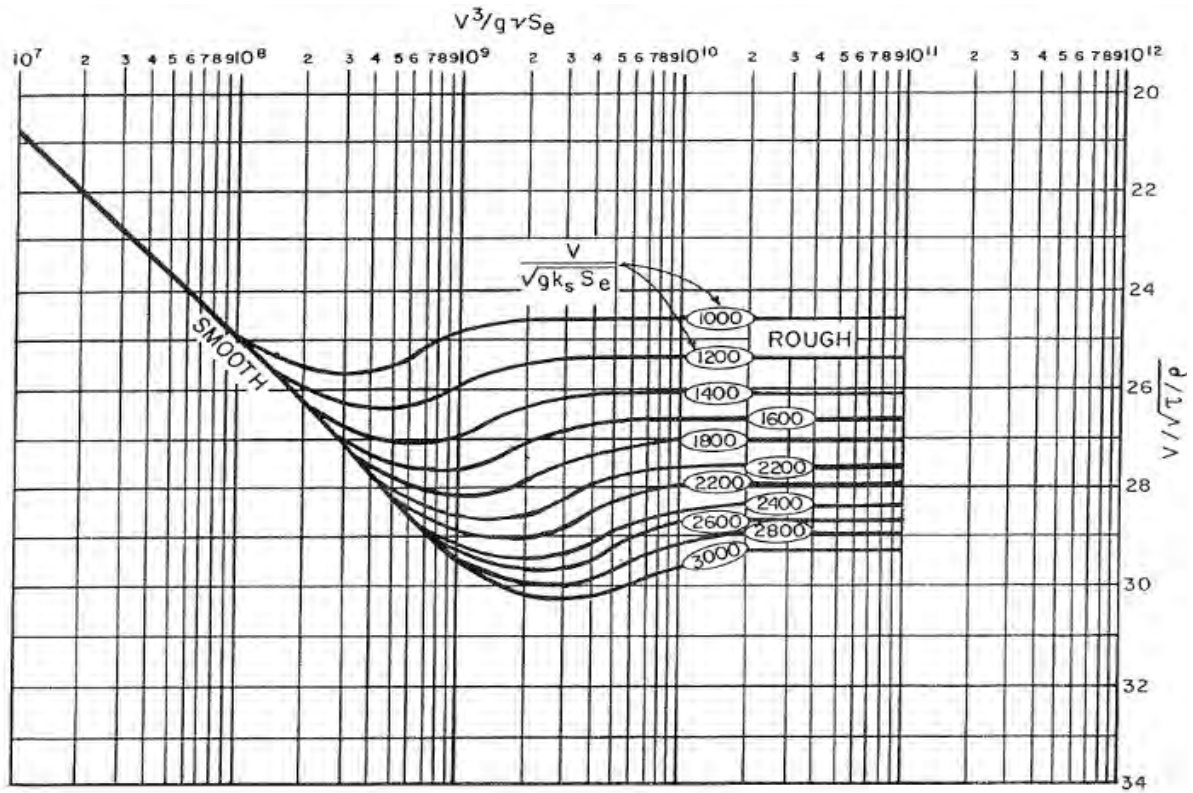
Value 1 8.08E+07

$$V / [(g D_{65} S_e)^{0.5}]$$

Value 2 126.8

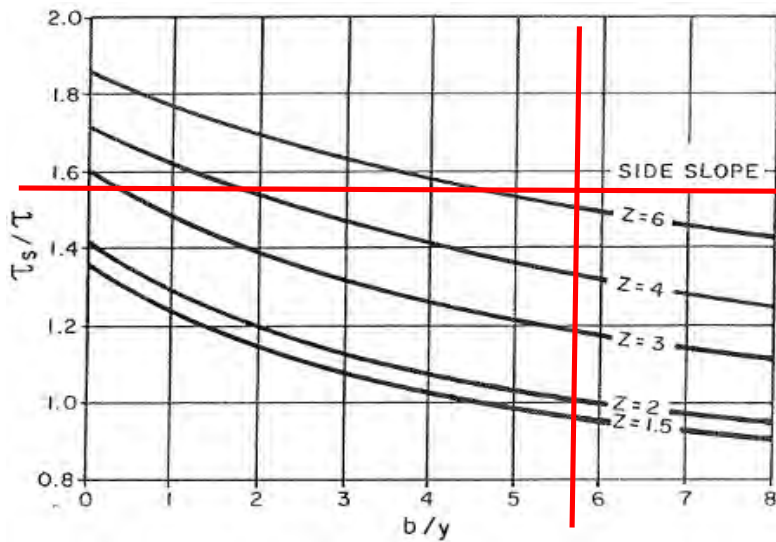
Graphic Solution of Reference Tractive Stress





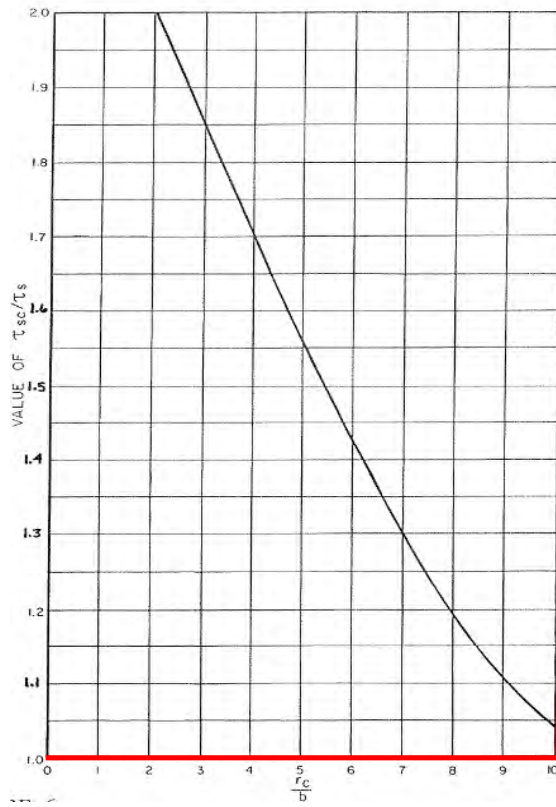
$V/\sqrt{\tau/\rho}$ From Graph Above 16.6
 Solving the above equation for τ 0.18 lb/ft²

Applied Maximum Tractive Stress, τ_s , on sides of straight trapezoidal channels



Bottom Width/Flow depth 5.80
 Horizontal/Vertical (Z) 6.20
 From Graph 1.57
 Solving for τ_s 0.28 lb/ft²

Actual Maximum Tractive Stress, τ_s on sides of trapezoidal channels within a curved reach



Radius of Curvature/Bottom Width

N/A

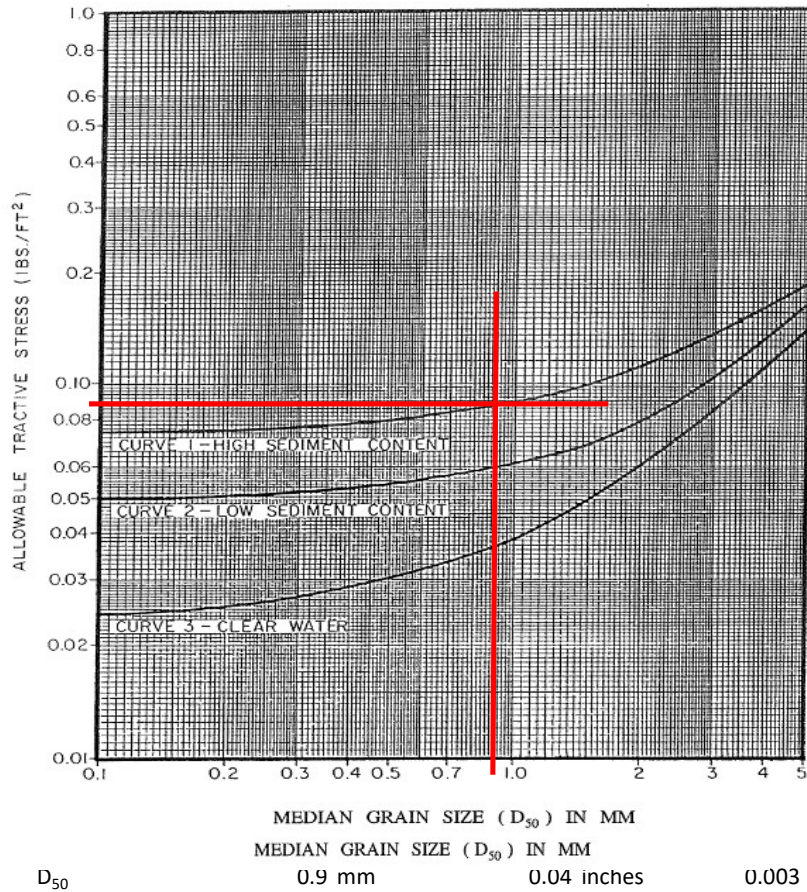
From Graph Above

1.00

Solving for τ_s

0.28 lb/ft²

Maximum Allowable Tractive Stress For Non-Cohesive Soils, $D_{75} < 0.25''$



Allowable Tractive Stress, from graph above 0.092 lb/ft²

Calculated Tractive Stress, τ 0.18 lb/ft²

Since the allowable tractive stress is less than the calculated tractive stress, the channel is erosive.

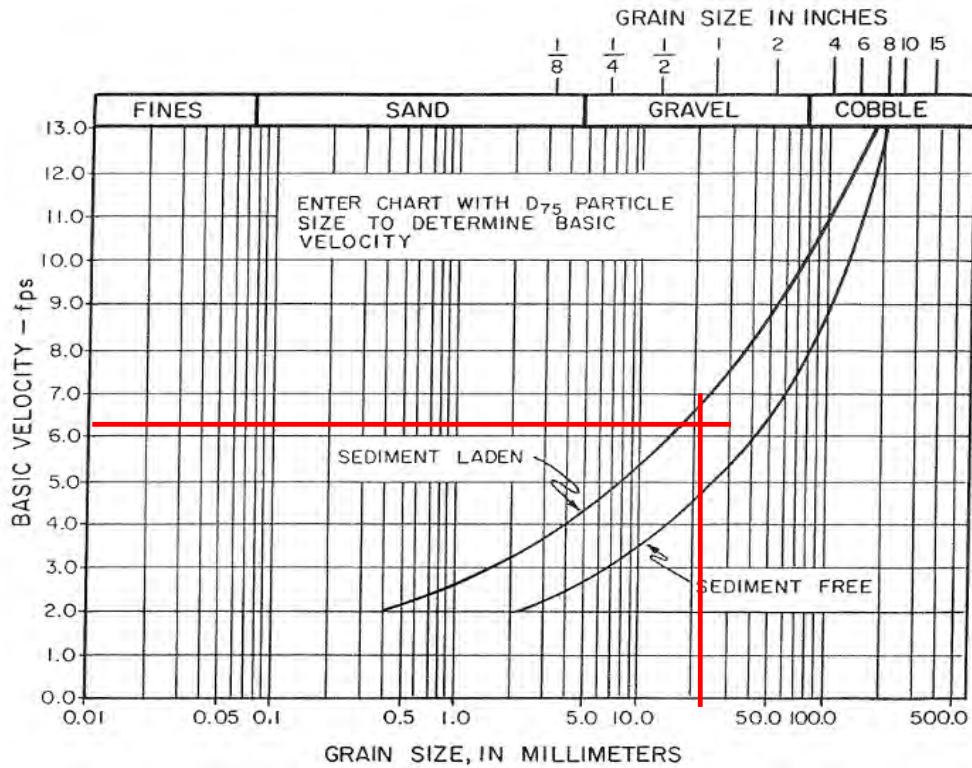
**Lateral Migration Setback Allowance for Riverine Floodplains
Level 2 Analysis**

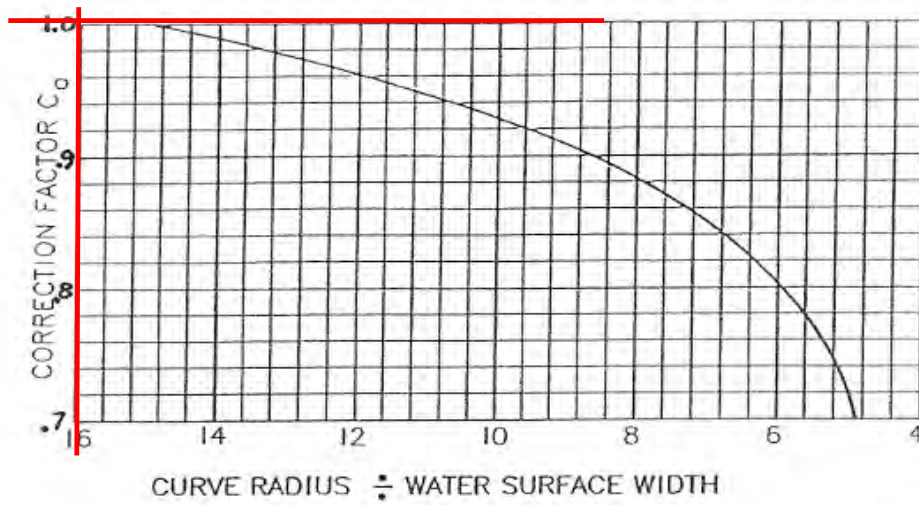
Cross Section 1496 - General Information

| | | | |
|-------------------------|------------------|--------------|------------|
| Bottom Width (b) | 24.9 feet | | |
| Side Slope (ft) | 15.5 Horizontal | 2.5 Vertical | |
| Channel Slope (S_c) | 0.004 feet/foot | | |
| Radius of Curvature (r) | 0 feet | | |
| Water Surface Width | 42.38 feet | | |
| Average Manning's n | 0.034 | | |
| | | | |
| Flow Depth (Y) | 4.29 feet | | |
| Flow Velocity (V) | 5.01 feet/second | | |
| | | | |
| D_{75} | 19 mm | 0.75 inches | 0.062 feet |
| D_{65} | 9.1 mm | 0.36 inches | 0.030 feet |
| D_{50} | 5.2 mm | 0.20 inches | 0.017 feet |

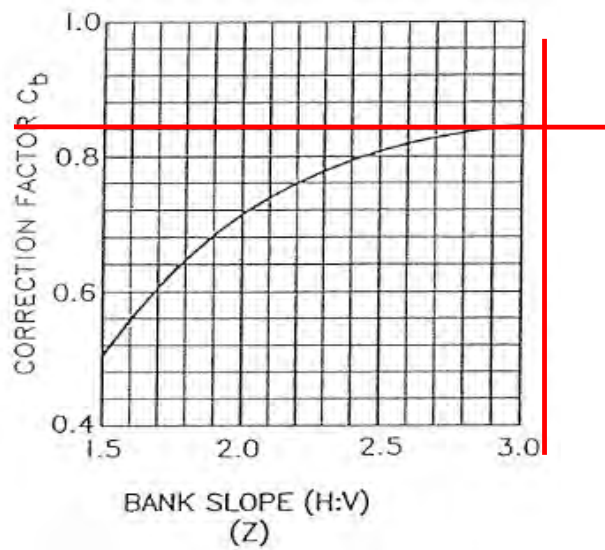
**Allowable Velocity Approach
(Assuming Sediment Laden Flow)**

Base Allowable Velocity for Earth Channels V_b 6.3 feet/sec

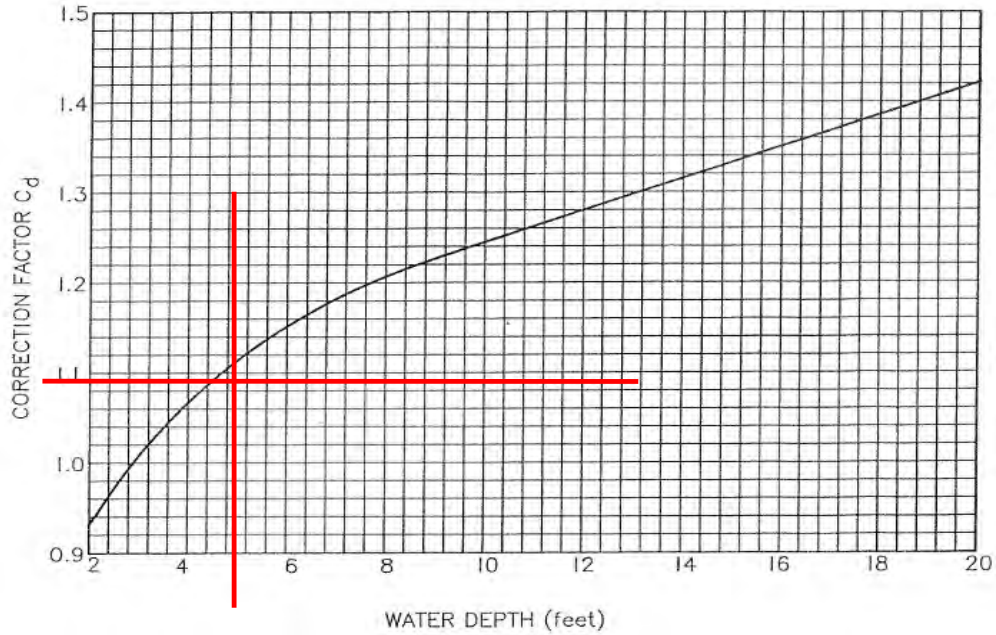




Curve Radius / Water Surface Width 0.0



Horizontal/Vertical (Z) 6.20



Flow Depth (Y)

4.29 feet

Maximum Allowable Velocity

5.77

feet/second

$$V_a = V_b \times C_a \times C_b \times C_d$$

Comparison of Flow Velocity of the Channel to the Maximum Allowable Velocity

Maximum Allowable Velocity

5.77

feet/second

Flow Velocity

5.01

feet/second

Since the computed flow velocity is less than the maximum allowable velocity, erosion is not expected to occur.

**Tractive Stress Analysis
(Assuming Sediment Laden Flow)**

D₇₅ 19 mm conversion 0.75 inches

Since the D75 is more than 0.25 inches and less than 5.0 inches, case 1 of the reference tractive method is used.

Assuming a water temperature of 60°F

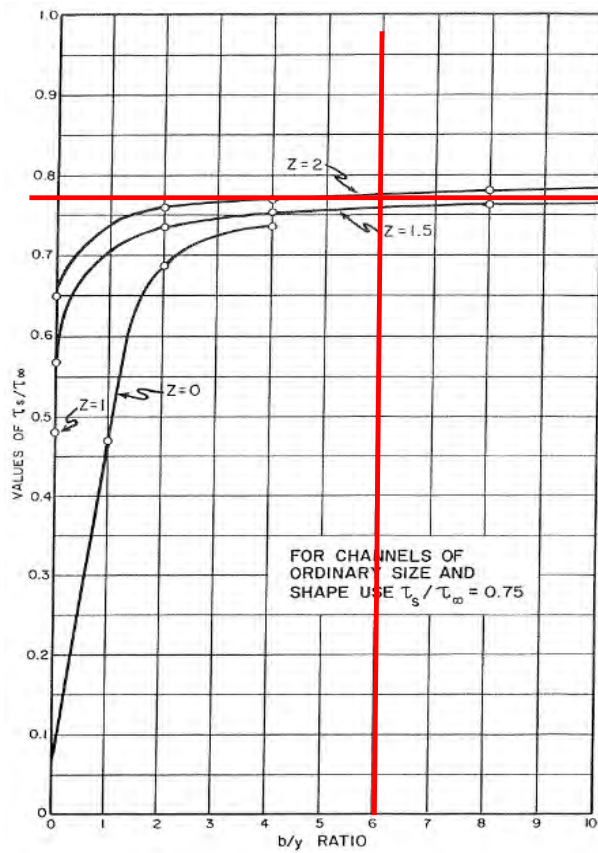
Kinematic Velocity (v) 0.0000121 ft² / sec
 Density (ρ) 1.94 slugs/ft³
 Gravity 32.17 ft/sec²
 Unit Weight of Water (γ) 62.4 lbs/ft³

Tractive Stress for Soils in an infinitely Wide Channel (τ_∞)

$$\gamma_w Y \left[\frac{D_{75}^{\frac{1}{6}}}{39n} \right]^2 S_e$$

0.241 lbs/ft²

Actual Maximum Tractive Stress, τ_s, on Sides of Straight Trapezoidal Channels

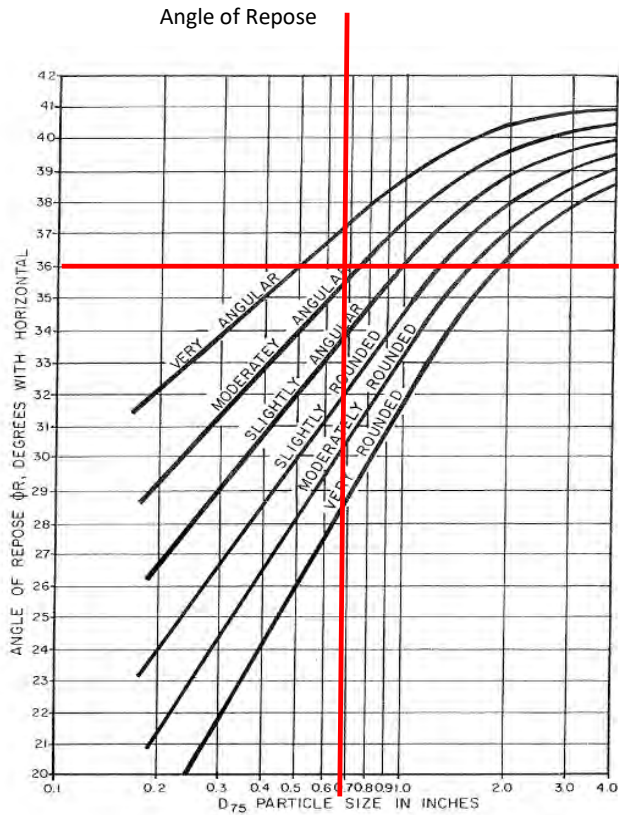


b/y Ratio 5.80 ft/ft
 Z (H/V) 6.20 ft/ft

 τ_s/τ_∞ 0.77

 τ_s 0.186 lbs/ft²

Allowable Tractive Stress (τ_s)



Moderately Angular
 D_{75} 0.75 inches
 From Chart (ϕ_R) 36 Degrees

Solving for Allowable Tractive Stress

$$0.4 \left[\frac{Z^2 - \cot^2 \phi_R}{1 + Z^2} \right]^{\frac{1}{2}} D_{75}$$

0.284 lbs/ft²

Allowable Tractive Stress, from calculation above 0.284 lb/ft²

Calculated Tractive Stress, τ 0.19 lb/ft²

Since the allowable tractive stress is more than the calculated tractive stress, the channel is not erosive.

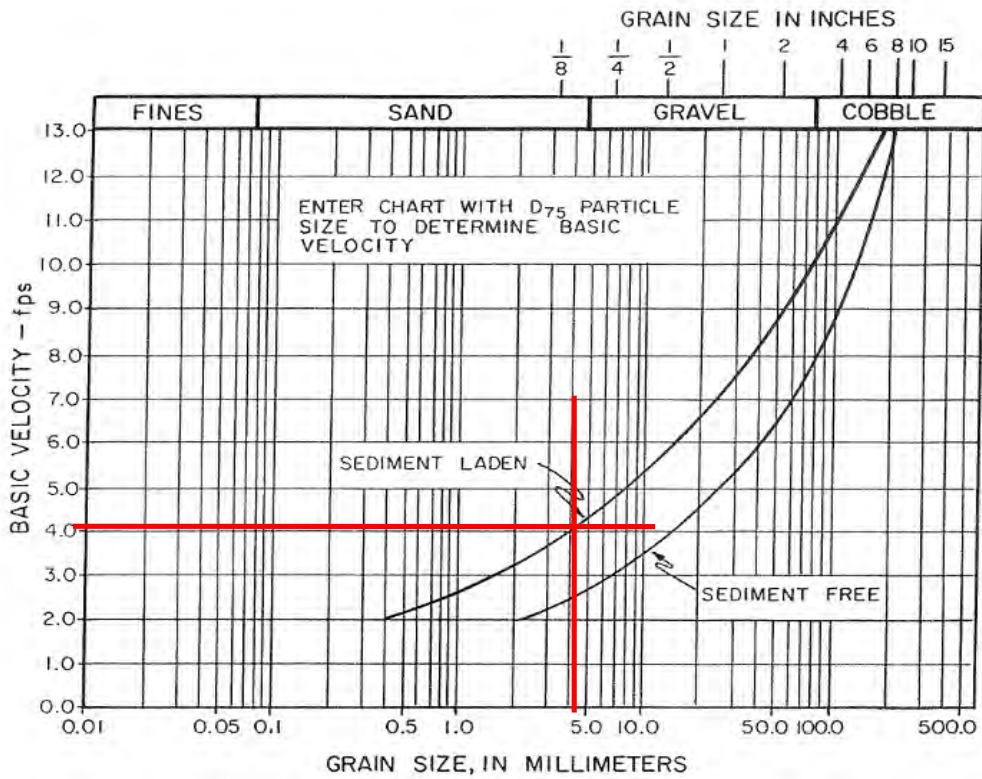
**Lateral Migration Setback Allowance for Riverine Floodplains
Level 2 Analysis**

Cross Section 1572 - General Information

| | | | |
|---------------------------------|------------------|--------------|------------|
| Bottom Width (b) | 25.47 feet | | |
| Side Slope (ft) | 9.7 Horizontal | 5.3 Vertical | |
| Channel Slope (S _e) | 0.0012 feet/foot | | |
| Radius of Curvature (r) | 0 feet | | |
| Water Surface Width | 39.98 feet | | |
| Average Manning's n | 0.026 | | |
| | | | |
| Flow Depth (Y) | 4.19 feet | | |
| Flow Velocity (V) | 3.48 feet/second | | |
| | | | |
| D ₇₅ | 4.4 mm | 0.17 inches | 0.014 feet |
| D ₆₅ | 3.7 mm | 0.15 inches | 0.012 feet |
| D ₅₀ | 0.9 mm | 0.04 inches | 0.003 feet |

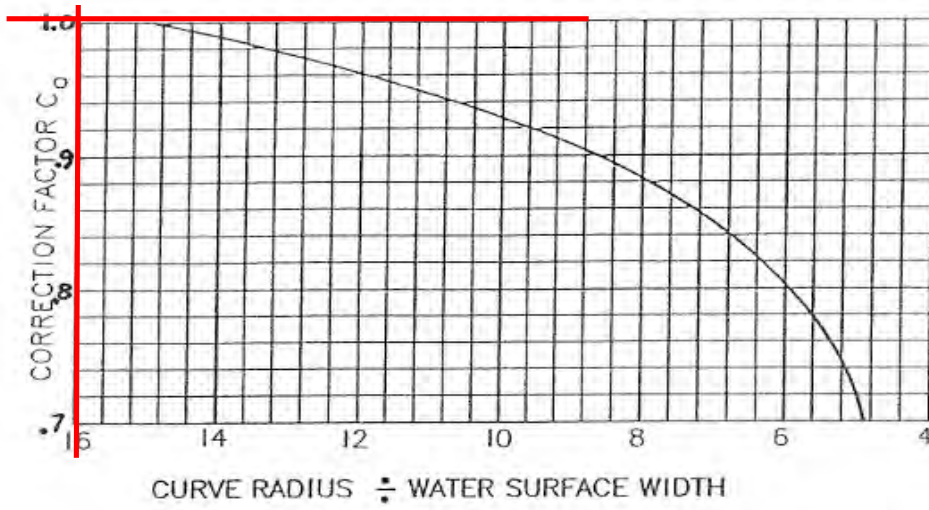
**Allowable Velocity Approach
(Assuming Sediment Laden Flow)**

Base Allowable Velocity for Earth Channels V_b 4.2 feet/sec



Correction Factor C_a For Channel Alignment

1

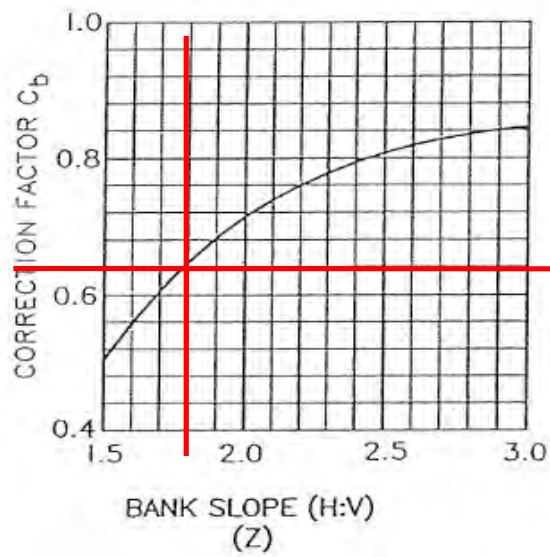


Curve Radius / Water Surface Width

0.0

Correction Factor C_b For Bank Slope

0.62

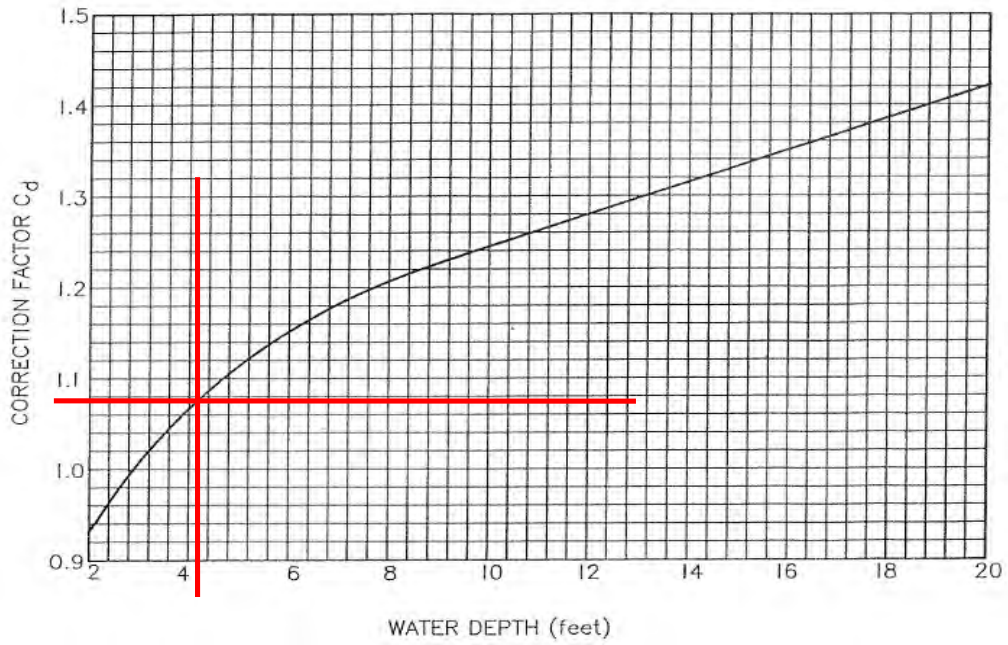


Horizontal/Vertical (Z)

1.83

Correction Factor C_d For Depth of Flow

1.08



Flow Depth (Y)

4.19 feet

Maximum Allowable Velocity

2.81

feet/second

$$V_a = V_b \times C_a \times C_b \times C_d$$

Comparison of Flow Velocity of the Channel to the Maximum Allowable Velocity

Maximum Allowable Velocity

2.81

feet/second

Flow Velocity

3.48

feet/second

Since the computed flow velocity exceeds the maximum allowable velocity, erosion may be expected to occur

**Tractive Stress Analysis
(Assuming Sediment Laden Flow)**

D_{75} 4.4 mm conversion 0.17 inches

Since D_{75} is less or equal to 0.25 inches, case 2 of reference tractive stress method is used.

Assuming a water temperature of 60°F

Kinematic Velocity (v) 0.0000121 ft² / sec
 Density (ρ) 1.94 slugs/ft³
 Gravity 32.17 ft/sec²

Finding Values Needed for Graphs

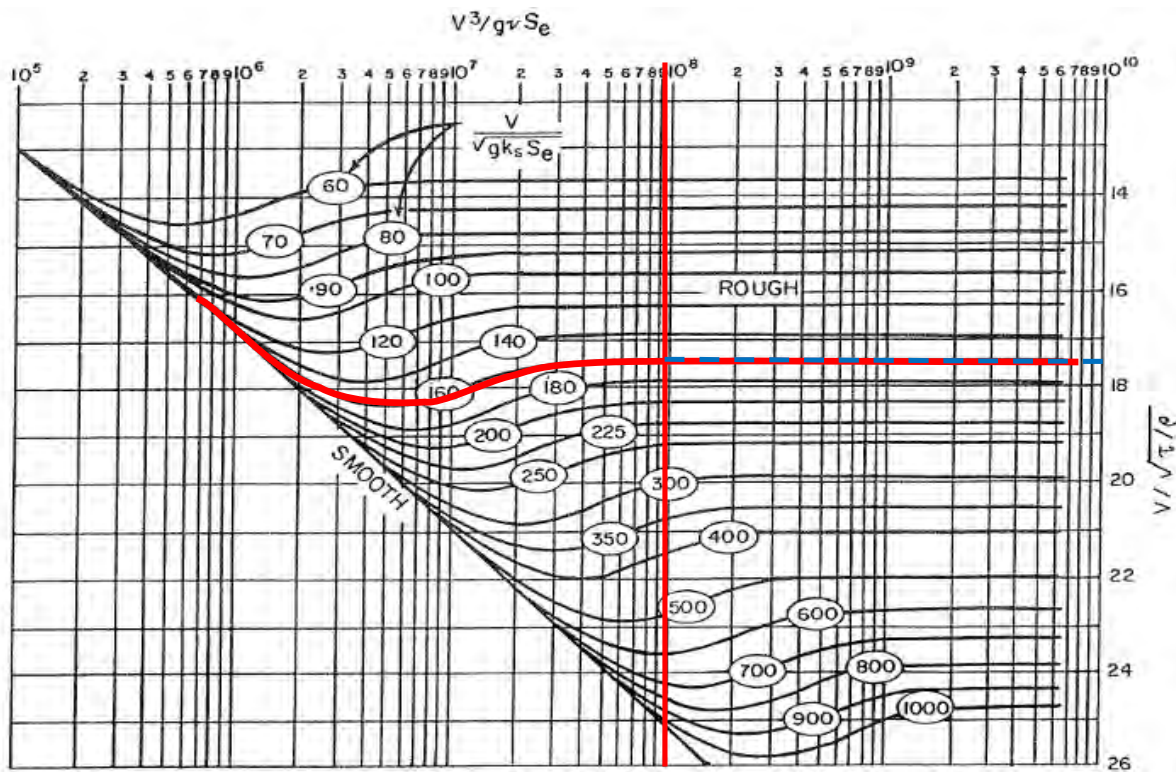
$$V^3 / (g v S_e)$$

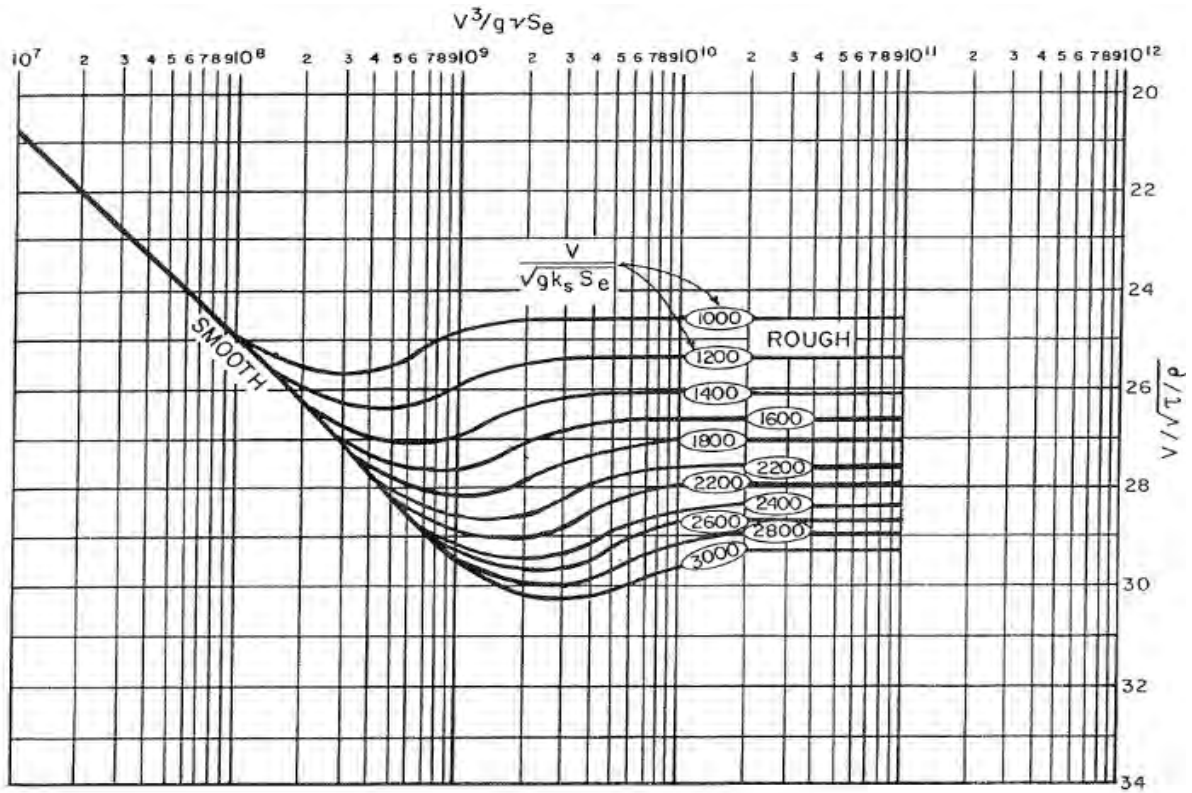
Value 1 9.02E+07

$$V / [(g D_{65} S_e)^{0.5}]$$

Value 2 160.8

Graphic Solution of Reference Tractive Stress



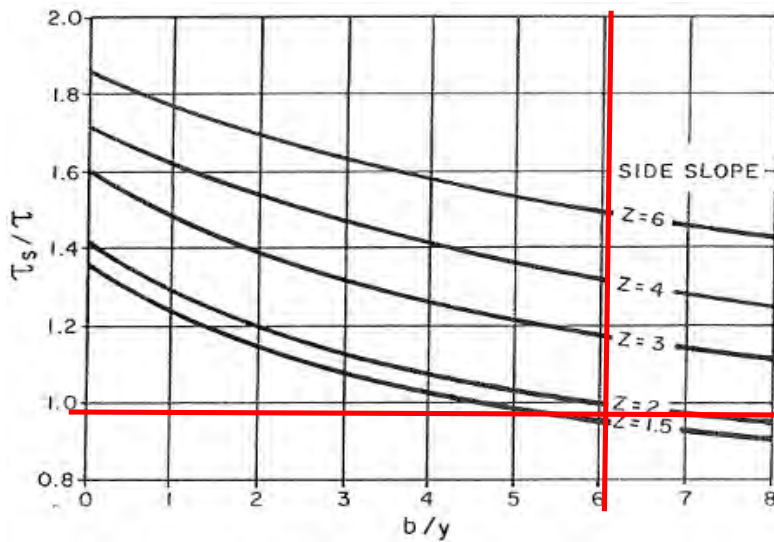


$$V/\sqrt{\tau/\rho}$$

From Graph Above 17.6

Solving the above equation for τ 0.08 lb/ft²

Applied Maximum Tractive Stress, τ_s , on sides of straight trapezoidal channels

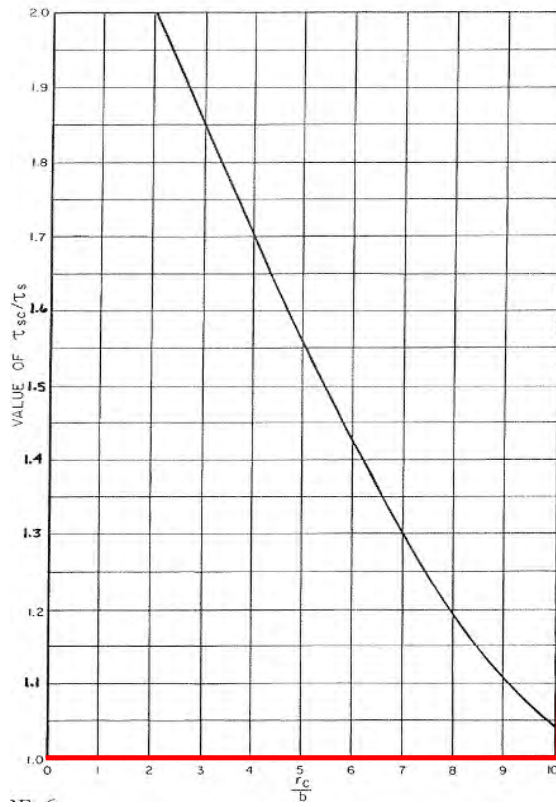


Bottom Width/Flow depth Horizontal/Vertical (Z) 6.08 1.83

From Graph 0.98

Solving for τ_s 0.07 lb/ft²

Actual Maximum Tractive Stress, τ_s on sides of trapezoidal channels within a curved reach



Radius of Curvature/Bottom Width

N/A

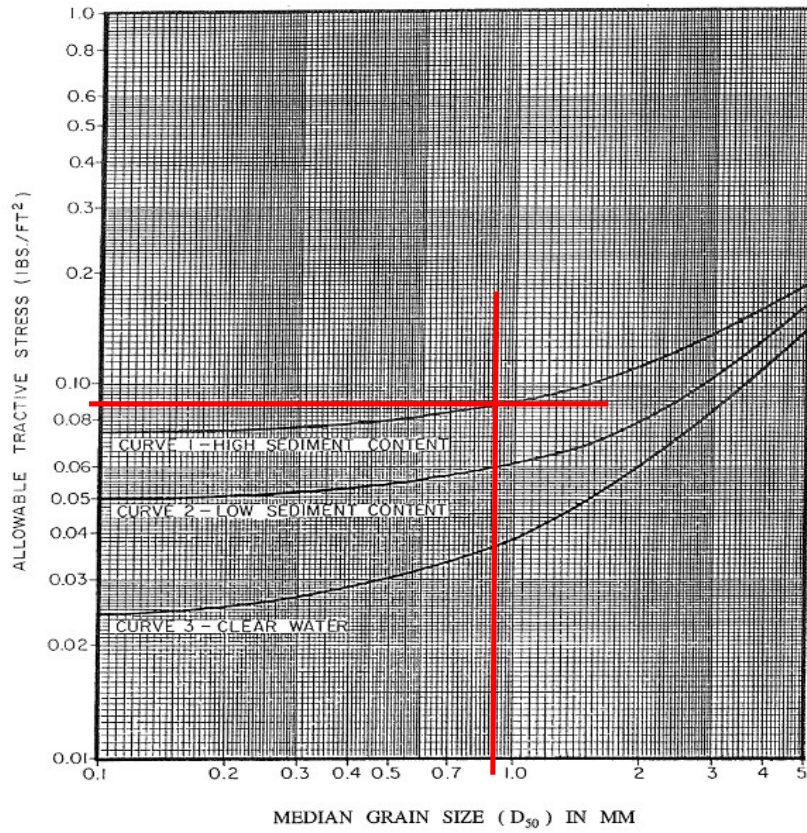
From Graph Above

1.00

Solving for τ_s

0.07 lb/ft²

Maximum Allowable Tractive Stress For Non-Cohesive Soils, $D_{75} < 0.25''$



D_{50} 0.9 mm 0.04 inches 0.003 feet

Allowable Tractive Stress, from graph above 0.092 lb/ft²

Calculated Tractive Stress, τ 0.08 lb/ft²

Since the allowable tractive stress is more than the calculated tractive stress, the channel is not erosive.

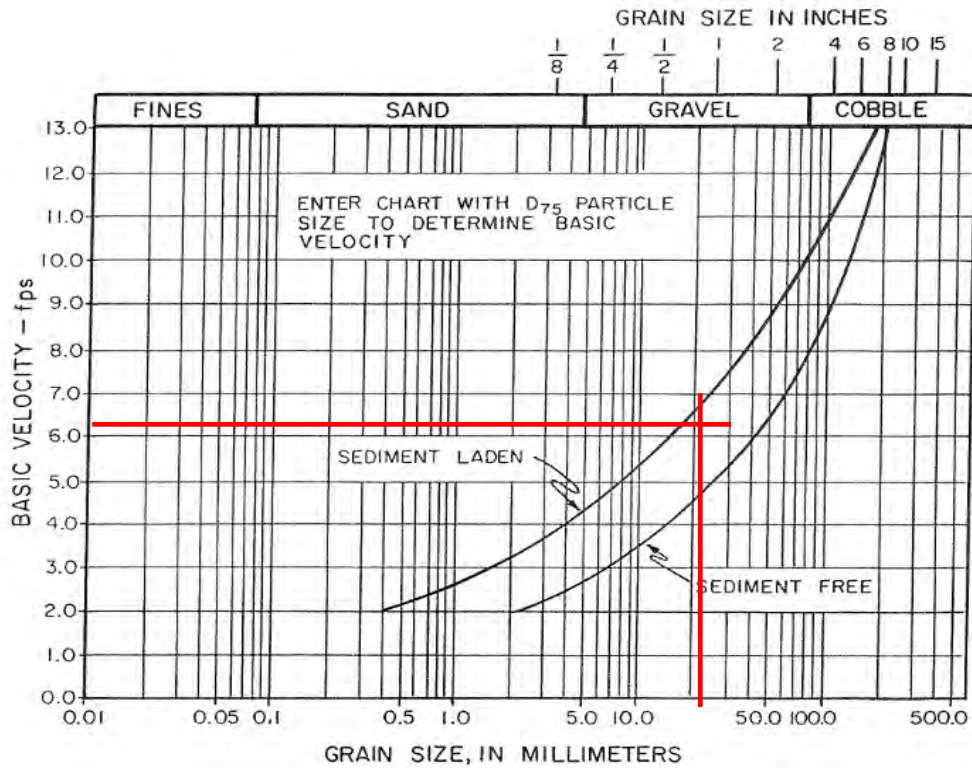
**Lateral Migration Setback Allowance for Riverine Floodplains
Level 2 Analysis**

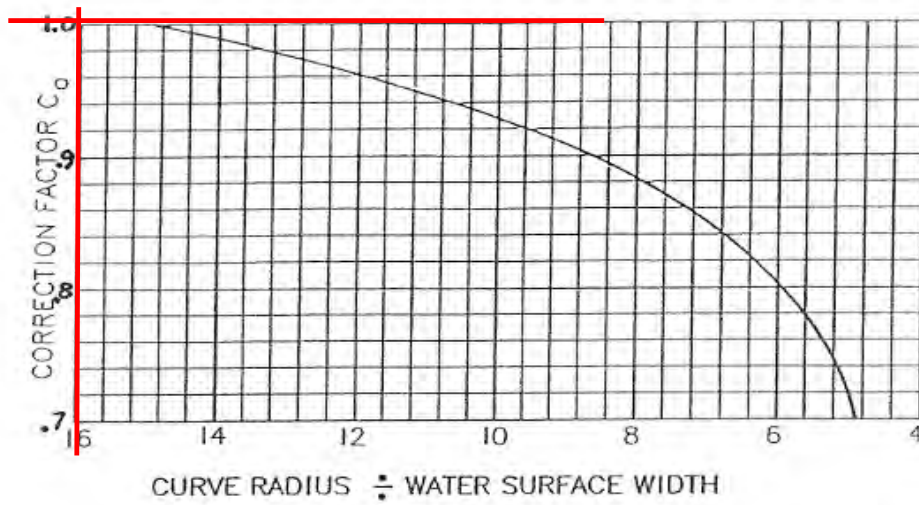
Cross Section 1572 - General Information

| | | | |
|-------------------------|------------------|--------------|------------|
| Bottom Width (b) | 25.47 feet | | |
| Side Slope (ft) | 9.7 Horizontal | 5.3 Vertical | |
| Channel Slope (S_c) | 0.0012 feet/foot | | |
| Radius of Curvature (r) | 0 feet | | |
| Water Surface Width | 39.98 feet | | |
| Average Manning's n | 0.026 | | |
| | | | |
| Flow Depth (Y) | 4.19 feet | | |
| Flow Velocity (V) | 3.48 feet/second | | |
| | | | |
| D ₇₅ | 19 mm | 0.75 inches | 0.062 feet |
| D ₆₅ | 9.1 mm | 0.36 inches | 0.030 feet |
| D ₅₀ | 5.2 mm | 0.20 inches | 0.017 feet |

**Allowable Velocity Approach
(Assuming Sediment Laden Flow)**

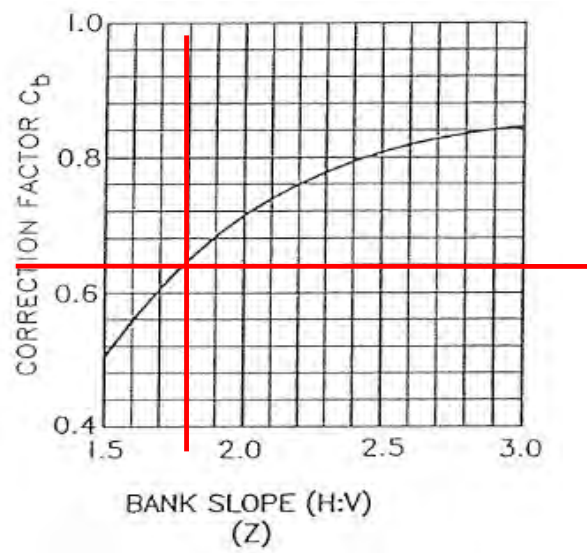
Base Allowable Velocity for Earth Channels V_b 6.3 feet/sec





Curve Radius / Water Surface Width

0.0

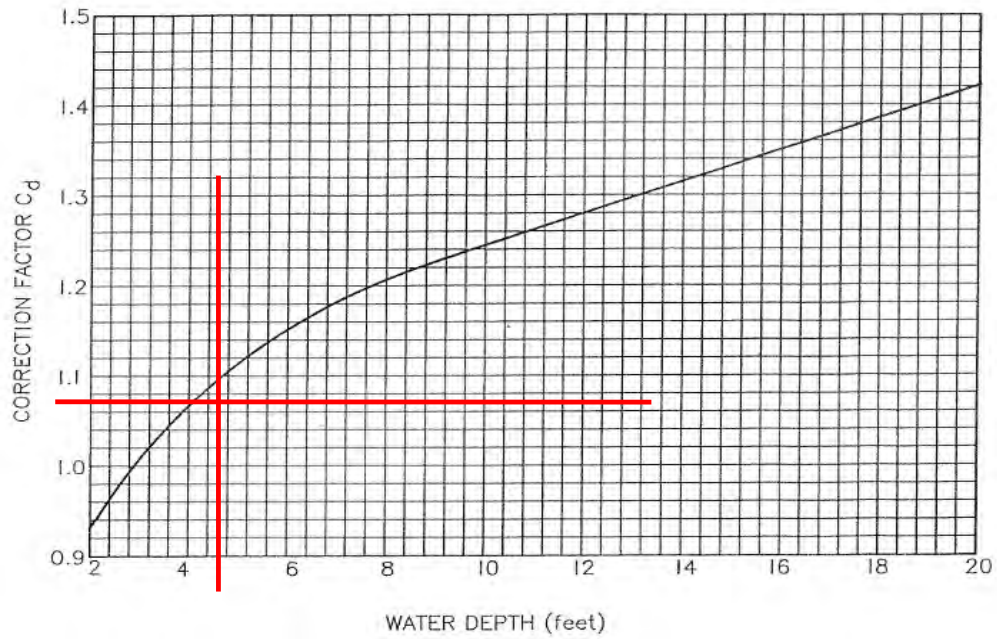


Horizontal/Vertical (Z)

1.83

Correction Factor C_d For Depth of Flow

1.07



Flow Depth (Y)

4.19 feet

Maximum Allowable Velocity

4.18

feet/second

$$V_a = V_b \times C_a \times C_b \times C_d$$

Comparison of Flow Velocity of the Channel to the Maximum Allowable Velocity

Maximum Allowable Velocity

4.18

feet/second

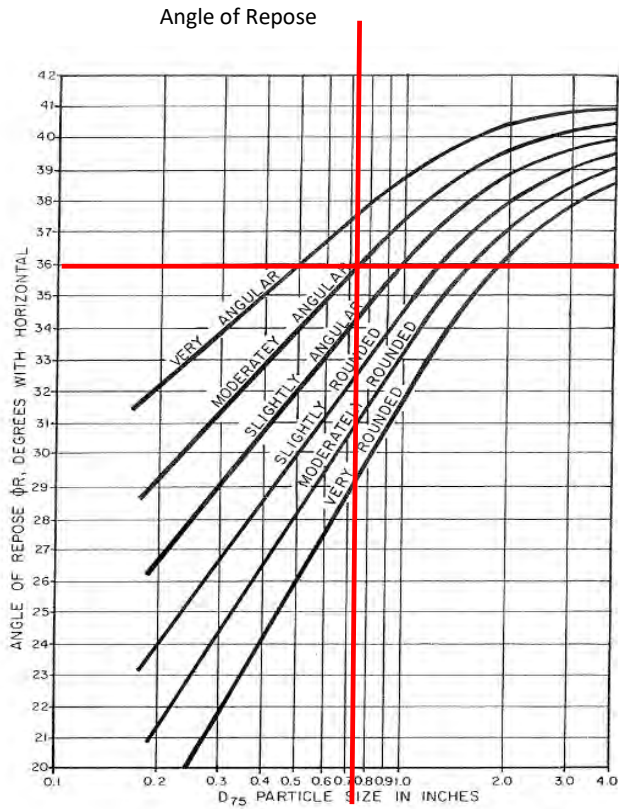
Flow Velocity

3.48

feet/second

Since the computed flow velocity is less than the maximum allowable velocity, erosion is not expected to occur.

Allowable Tractive Stress (τ_s)



Moderately Angular
 D_{75} 0.75 inches
 From Chart (ϕR) 36 Degrees

Solving for Allowable Tractive Stress

$$0.4 \left[\frac{Z^2 - \cot^2 \phi R}{1 + Z^2} \right]^{\frac{1}{2}} D_{75}$$

0.176 lbs/ft²

Allowable Tractive Stress, from calculation above 0.176 lb/ft²

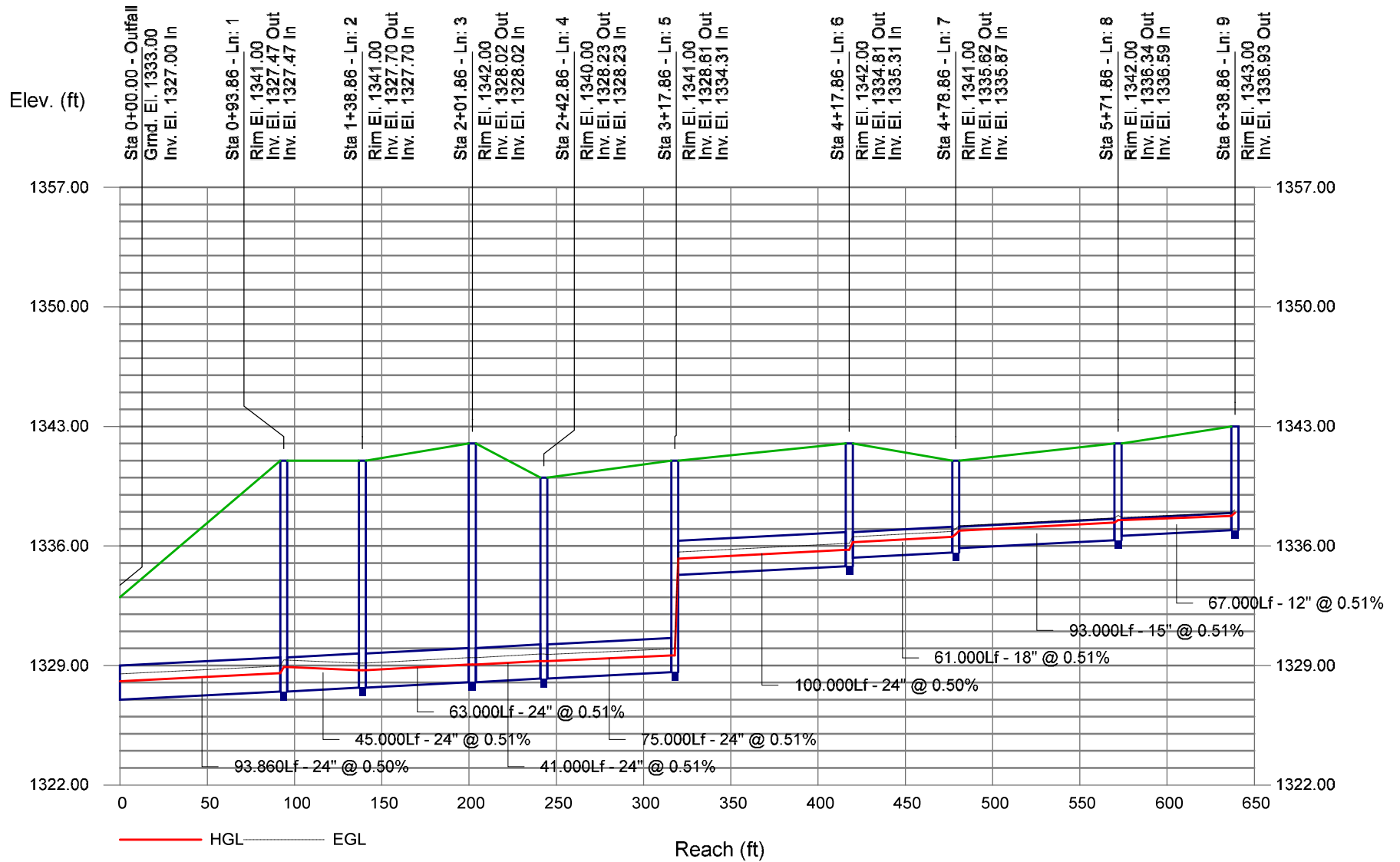
Calculated Tractive Stress, τ 0.09 lb/ft²

Since the allowable tractive stress is more than the calculated tractive stress, the channel is not erosive.



Appendix I – STORM DRAIN PROFILES

Storm Sewer Profile



Storm Sewer Inventory Report

| Line No. | Alignment | | | | Flow Data | | | | Physical Data | | | | | | | | Line ID |
|----------|----------------|------------------|------------------|-----------|---------------|----------------|------------------|------------------|-------------------|----------------|-------------------|----------------|------------|-------------|------------------|--------------------|---------|
| | Dnstr Line No. | Line Length (ft) | Defl angle (deg) | Junc Type | Known Q (cfs) | Drng Area (ac) | Runoff Coeff (C) | Inlet Time (min) | Invert El Dn (ft) | Line Slope (%) | Invert El Up (ft) | Line Size (in) | Line Shape | N Value (n) | J-Loss Coeff (K) | Inlet/ Rim El (ft) | |
| 1 | End | 93.860 | 37.070 | DrGrt | 0.64 | 0.00 | 0.00 | 0.0 | 1327.00 | 0.50 | 1327.47 | 24 | Cir | 0.013 | 0.84 | 1341.00 | |
| 2 | 1 | 45.000 | -30.321 | DrGrt | 0.01 | 0.00 | 0.00 | 0.0 | 1327.47 | 0.51 | 1327.70 | 24 | Cir | 0.013 | 1.48 | 1341.00 | |
| 3 | 2 | 63.000 | -80.804 | DrGrt | 0.01 | 0.00 | 0.00 | 0.0 | 1327.70 | 0.51 | 1328.02 | 24 | Cir | 0.013 | 1.45 | 1342.00 | |
| 4 | 3 | 41.000 | 74.055 | DrGrt | 0.70 | 0.00 | 0.00 | 0.0 | 1328.02 | 0.51 | 1328.23 | 24 | Cir | 0.013 | 1.50 | 1340.00 | |
| 5 | 4 | 75.000 | -90.000 | DrGrt | 0.32 | 0.00 | 0.00 | 0.0 | 1328.23 | 0.51 | 1328.61 | 24 | Cir | 0.013 | 0.50 | 1341.00 | |
| 6 | 5 | 100.000 | -0.541 | DrGrt | 2.25 | 0.00 | 0.00 | 0.0 | 1334.31 | 0.50 | 1334.81 | 24 | Cir | 0.013 | 0.50 | 1342.00 | |
| 7 | 6 | 61.000 | 1.199 | DrGrt | 0.50 | 0.00 | 0.00 | 0.0 | 1335.31 | 0.51 | 1335.62 | 18 | Cir | 0.013 | 0.50 | 1341.00 | |
| 8 | 7 | 93.000 | -0.049 | DrGrt | 2.20 | 0.00 | 0.00 | 0.0 | 1335.87 | 0.51 | 1336.34 | 15 | Cir | 0.013 | 0.50 | 1342.00 | |
| 9 | 8 | 67.000 | 0.259 | DrGrt | 2.40 | 0.00 | 0.00 | 0.0 | 1336.59 | 0.51 | 1336.93 | 12 | Cir | 0.013 | 1.00 | 1343.00 | |

Project File: Gold Dust Storm Drain.stm

Number of lines: 9

Date: 2/2/2023

Storm Sewer Summary Report

| Line No. | Line ID | Flow rate (cfs) | Line Size (in) | Line shape | Line length (ft) | Invert EL Dn (ft) | Invert EL Up (ft) | Line Slope (%) | HGL Down (ft) | HGL Up (ft) | Minor loss (ft) | HGL Junct (ft) | Dns Line No. | Junction Type |
|----------|---------|-----------------|----------------|------------|------------------|-------------------|-------------------|----------------|---------------|-------------|-----------------|----------------|--------------|---------------|
| 1 | | 9.03 | 24 | Cir | 93.860 | 1327.00 | 1327.47 | 0.501 | 1328.08 | 1328.55 | 0.36 | 1328.91 | End | DropGrate |
| 2 | | 8.39 | 24 | Cir | 45.000 | 1327.47 | 1327.70 | 0.511 | 1328.91 | 1328.73 | n/a | 1328.73 | 1 | DropGrate |
| 3 | | 8.38 | 24 | Cir | 63.000 | 1327.70 | 1328.02 | 0.508 | 1328.73 | 1329.05 | n/a | 1329.05 | 2 | DropGrate |
| 4 | | 8.37 | 24 | Cir | 41.000 | 1328.02 | 1328.23 | 0.512 | 1329.05 | 1329.26 | n/a | 1329.26 | 3 | DropGrate |
| 5 | | 7.67 | 24 | Cir | 75.000 | 1328.23 | 1328.61 | 0.507 | 1329.26 | 1329.59 | n/a | 1329.59 | 4 | DropGrate |
| 6 | | 7.35 | 24 | Cir | 100.000 | 1334.31 | 1334.81 | 0.500 | 1335.26 | 1335.77 | n/a | 1335.77 | 5 | DropGrate |
| 7 | | 5.10 | 18 | Cir | 61.000 | 1335.31 | 1335.62 | 0.508 | 1336.22 | 1336.53 | 0.16 | 1336.69 | 6 | DropGrate |
| 8 | | 4.60 | 15 | Cir | 93.000 | 1335.87 | 1336.34 | 0.505 | 1336.90 | 1337.37 | 0.14 | 1337.51 | 7 | DropGrate |
| 9 | | 2.40 | 12 | Cir | 67.000 | 1336.59 | 1336.93 | 0.508 | 1337.51 | 1337.76 | 0.18 | 1337.95 | 8 | DropGrate |

Project File: Gold Dust Storm Drain.stm

Number of lines: 9

Run Date: 2/2/2023

NOTES: Known Qs only

Storm Sewer Tabulation

| Station | | Len (ft) | Drng Area | | Rnoff coeff (C) | Area x C | | Tc | | Rain (l) (in/hr) | Total flow (cfs) | Cap full (cfs) | Vel (ft/s) | Pipe | | Invert Elev | | HGL Elev | | Grnd / Rim Elev | | Line ID |
|---------|------------|-------------|--------------|---------------|-----------------------|----------|-------|----------------|---------------|------------------------|------------------------|----------------------|---------------|--------------|--------------|-------------|------------|------------|------------|-----------------|------------|---------|
| Line | To Line | | Incr (ac) | Total (ac) | | Incr | Total | Inlet (min) | Syst (min) | | | | | Size (in) | Slope (%) | Dn (ft) | Up (ft) | Dn (ft) | Up (ft) | Dn (ft) | Up (ft) | |
| 1 | End | 93.860 | 0.00 | 0.00 | 0.00 | 0.00 | 0.00 | 0.0 | 3.3 | 0.0 | 9.03 | 16.00 | 5.23 | 24 | 0.50 | 1327.00 | 1327.47 | 1328.08 | 1328.55 | 0.00 | 1341.00 | |
| 2 | 1 | 45.000 | 0.00 | 0.00 | 0.00 | 0.00 | 0.00 | 0.0 | 3.0 | 0.0 | 8.39 | 16.17 | 4.31 | 24 | 0.51 | 1327.47 | 1327.70 | 1328.91 | 1328.73 | 1341.00 | 1341.00 | |
| 3 | 2 | 63.000 | 0.00 | 0.00 | 0.00 | 0.00 | 0.00 | 0.0 | 2.6 | 0.0 | 8.38 | 16.12 | 5.13 | 24 | 0.51 | 1327.70 | 1328.02 | 1328.73 | 1329.05 | 1341.00 | 1342.00 | |
| 4 | 3 | 41.000 | 0.00 | 0.00 | 0.00 | 0.00 | 0.00 | 0.0 | 2.4 | 0.0 | 8.37 | 16.19 | 5.13 | 24 | 0.51 | 1328.02 | 1328.23 | 1329.05 | 1329.26 | 1342.00 | 1340.00 | |
| 5 | 4 | 75.000 | 0.00 | 0.00 | 0.00 | 0.00 | 0.00 | 0.0 | 1.8 | 0.0 | 7.67 | 16.10 | 4.84 | 24 | 0.51 | 1328.23 | 1328.61 | 1329.26 | 1329.59 | 1340.00 | 1341.00 | |
| 6 | 5 | 100.000 | 0.00 | 0.00 | 0.00 | 0.00 | 0.00 | 0.0 | 1.1 | 0.0 | 7.35 | 15.99 | 4.95 | 24 | 0.50 | 1334.31 | 1334.81 | 1335.26 | 1335.77 | 1341.00 | 1342.00 | |
| 7 | 6 | 61.000 | 0.00 | 0.00 | 0.00 | 0.00 | 0.00 | 0.0 | 0.8 | 0.0 | 5.10 | 7.49 | 4.55 | 18 | 0.51 | 1335.31 | 1335.62 | 1336.22 | 1336.53 | 1342.00 | 1341.00 | |
| 8 | 7 | 93.000 | 0.00 | 0.00 | 0.00 | 0.00 | 0.00 | 0.0 | 0.4 | 0.0 | 4.60 | 4.59 | 4.26 | 15 | 0.51 | 1335.87 | 1336.34 | 1336.90 | 1337.37 | 1341.00 | 1342.00 | |
| 9 | 8 | 67.000 | 0.00 | 0.00 | 0.00 | 0.00 | 0.00 | 0.0 | 0.0 | 0.0 | 2.40 | 2.54 | 3.31 | 12 | 0.51 | 1336.59 | 1336.93 | 1337.51 | 1337.76 | 1342.00 | 1343.00 | |

Project File: Gold Dust Storm Drain.stm

Number of lines: 9

Run Date: 2/2/2023

NOTES: Known Qs only ; c = cir e = ellip b = box

| Line No. | Area Dn (sqft) | Area Up (sqft) | Byp Ln No | Coeff C1 (C) | Coeff C2 (C) | Coeff C3 (C) | Capac Full (cfs) | Crit Depth (ft) | Cross SI, Sw (ft/ft) | Cross SI, Sx (ft/ft) | Curb Len (ft) | Defl Ang (Deg) | Depth Dn (ft) | Depth Up (ft) | DnStm Ln No | Drng Area (ac) | Easting X (ft) | EGL Dn (ft) | EGL Up (ft) | Energy Loss (ft) |
|----------|-------------------|-------------------|-----------|-----------------|-----------------|-----------------|---------------------|--------------------|-------------------------|-------------------------|------------------|-------------------|------------------|------------------|-------------|-------------------|-------------------|----------------|----------------|---------------------|
| 1 | 1.71 | 1.72 | Sag | 0.20 | 0.50 | 0.90 | 16.00 | 1.07 | 0.050 | 0.020 | | 37.070 | 1.08 | 1.08** | Outfall | 0.00 | 264.55 | 1328.50 | 1328.97 | 0.465 |
| 2 | 1.63 | 1.63 | 1 | 0.20 | 0.50 | 0.90 | 16.17 | 1.03 | 0.050 | 0.020 | | -30.321 | 1.44 | 1.03** | 1 | 0.00 | 309.23 | 1329.32 | 1329.14 | 0.000 |
| 3 | 1.63 | 1.63 | 2 | 0.20 | 0.50 | 0.90 | 16.12 | 1.03 | 0.050 | 0.020 | | -80.804 | 1.03 | 1.03** | 2 | 0.00 | 326.54 | 1329.14 | 1329.46 | 0.000 |
| 4 | 1.63 | 1.63 | 3 | 0.20 | 0.50 | 0.90 | 16.19 | 1.03 | 0.050 | 0.020 | | 74.055 | 1.03 | 1.03** | 3 | 0.00 | 367.54 | 1329.46 | 1329.67 | 0.000 |
| 5 | 1.54 | 1.54 | 4 | 0.20 | 0.50 | 0.90 | 16.10 | 0.98 | 0.050 | 0.020 | | -90.000 | 1.03 | 0.98** | 4 | 0.00 | 367.54 | 1329.65 | 1329.98 | 0.000 |
| 6 | 1.48 | 1.50 | 5 | 0.20 | 0.50 | 0.90 | 15.99 | 0.96 | 0.050 | 0.020 | | -0.541 | 0.95 | 0.96** | 5 | 0.00 | 366.60 | 1335.64 | 1336.15 | 0.000 |
| 7 | 1.12 | 1.12 | 6 | 0.20 | 0.50 | 0.90 | 7.49 | 0.87 | 0.050 | 0.020 | | 1.199 | 0.91 | 0.91 | 6 | 0.00 | 367.30 | 1336.54 | 1336.85 | 0.309 |
| 8 | 1.08 | 1.08 | 7 | 0.20 | 0.50 | 0.90 | 4.59 | 0.87 | 0.050 | 0.020 | | -0.049 | 1.03 | 1.03 | 7 | 0.00 | 368.29 | 1337.18 | 1337.65 | 0.469 |
| 9 | 0.76 | 0.70 | 8 | 0.20 | 0.50 | 0.90 | 2.54 | 0.66 | 0.050 | 0.020 | | 0.259 | 0.92 | 0.83 | 8 | 0.00 | 369.30 | 1337.67 | 1337.95 | 0.280 |

Project File: Gold Dust Storm Drain.stm Number of lines: 9 Date: 2/2/2023

NOTES: ** Critical depth

MyReport

| Flow Rate | Sf Ave | Sf Dn | Grate Area | Grate Len | Grate Width | Gnd/Rim El Dn | Gnd/Rim El Up | Gutter Depth | Gutter Slope | Gutter Spread | Gutter Width | HGL Dn | HGL Up | HGL Jnct | HGL Jmp Dn | HGL Jmp Up | Incr CxA | Incr Q | Inlet Depth | Inlet Eff |
|-----------|---------|---------|------------|-----------|-------------|---------------|---------------|--------------|--------------|---------------|--------------|---------|---------|----------|------------|------------|----------|--------|-------------|-----------|
| (cfs) | (ft/ft) | (ft/ft) | (sqft) | (ft) | (ft) | (ft) | (ft) | (ft) | (ft/ft) | (ft) | (ft) | (ft) | (ft) | (ft) | (ft) | (ft) | | (cfs) | (ft) | (%) |
| 9.03 | 0.496 | 0.493 | 2.00 | 2.00 | 2.00 | 0.00 | 1341.00 | 0.09 | Sag | 10.92 | 2.00 | 1328.08 | 1328.55 | 1328.91 | | | 0.00 | 0.64 | 0.09 | 100 |
| 8.39 | 0.000 | 0.000 | 2.00 | 2.00 | 2.00 | 1341.00 | 1341.00 | 0.01 | Sag | 2.56 | 2.00 | 1328.91 | 1328.73 | 1328.73 | | | 0.00 | 0.01 | 0.01 | 100 |
| 8.38 | 0.000 | 0.000 | 2.00 | 2.00 | 2.00 | 1341.00 | 1342.00 | 0.01 | Sag | 2.56 | 2.00 | 1328.73 | 1329.05 | 1329.05 | | | 0.00 | 0.01 | 0.01 | 100 |
| 8.37 | 0.000 | 0.000 | 2.00 | 2.00 | 2.00 | 1342.00 | 1340.00 | 0.09 | Sag | 11.46 | 2.00 | 1329.05 | 1329.26 | 1329.26 | | | 0.00 | 0.70 | 0.09 | 100 |
| 7.67 | 0.000 | 0.000 | 2.00 | 2.00 | 2.00 | 1340.00 | 1341.00 | 0.06 | Sag | 7.61 | 2.00 | 1329.26 | 1329.59 | 1329.59 | | | 0.00 | 0.32 | 0.06 | 100 |
| 7.35 | 0.000 | 0.000 | 2.00 | 2.00 | 2.00 | 1341.00 | 1342.00 | 0.21 | Sag | 22.62 | 2.00 | 1335.26 | 1335.77 | 1335.77 | | | 0.00 | 2.25 | 0.21 | 100 |
| 5.10 | 0.507 | 0.507 | 2.00 | 2.00 | 2.00 | 1342.00 | 1341.00 | 0.08 | Sag | 9.56 | 2.00 | 1336.22 | 1336.53 | 1336.69 | | | 0.00 | 0.50 | 0.08 | 100 |
| 4.60 | 0.505 | 0.505 | 2.00 | 2.00 | 2.00 | 1341.00 | 1342.00 | 0.20 | Sag | 22.31 | 2.00 | 1336.90 | 1337.37 | 1337.51 | | | 0.00 | 2.20 | 0.20 | 100 |
| 2.40 | 0.418 | 0.394 | 2.00 | 2.00 | 2.00 | 1342.00 | 1343.00 | 0.22 | Sag | 23.53 | 2.00 | 1337.51 | 1337.76 | 1337.95 | | | 0.00 | 2.40 | 0.22 | 100 |

Project File: Gold Dust Storm Drain.stm Number of lines: 9 Date: 2/2/2023

NOTES: ** Critical depth

| Line Length | Line Size | Line Slope | Line Type | Local Depr | n-val Gutter | n-val Pipe | Minor Loss | Northing Y | Pipe Travel | Q Byp | Q Capt | Q Carry | Line Rise | Runoff Coeff | Line Span | Area A1 | Area A2 | Area A3 | Tc | Throat Ht | Total Area | Total CxA |
|-------------|-----------|------------|-----------|------------|--------------|------------|------------|------------|-------------|-------|--------|---------|-----------|--------------|-----------|---------|---------|---------|-------|-----------|------------|-----------|
| (ft) | (in) | (%) | | (in) | | | (ft) | (ft) | (min) | (cfs) | (cfs) | (cfs) | (in) | (C) | (in) | (ac) | (ac) | (ac) | (min) | (in) | (ac) | |
| 93.860 | 24 | 0.50 | Cir | | | 0.013 | 0.36 | 82.24 | 0.54 | 0.00 | 0.64 | 0.00 | 24 | 0.00 | 24 | 0.00 | 0.00 | 0.00 | 3.3 | | 0.00 | 0.00 |
| 45.000 | 24 | 0.51 | Cir | | | 0.013 | n/a | 76.95 | 0.28 | 0.00 | 0.01 | 0.00 | 24 | 0.00 | 24 | 0.00 | 0.00 | 0.00 | 3.0 | | 0.00 | 0.00 |
| 63.000 | 24 | 0.51 | Cir | | | 0.013 | n/a | 137.52 | 0.39 | 0.00 | 0.01 | 0.00 | 24 | 0.00 | 24 | 0.00 | 0.00 | 0.00 | 2.6 | | 0.00 | 0.00 |
| 41.000 | 24 | 0.51 | Cir | | | 0.013 | n/a | 137.52 | 0.26 | 0.00 | 0.70 | 0.00 | 24 | 0.00 | 24 | 0.00 | 0.00 | 0.00 | 2.4 | | 0.00 | 0.00 |
| 75.000 | 24 | 0.51 | Cir | | | 0.013 | n/a | 212.52 | 0.51 | 0.00 | 0.32 | 0.00 | 24 | 0.00 | 24 | 0.00 | 0.00 | 0.00 | 1.8 | | 0.00 | 0.00 |
| 100.000 | 24 | 0.50 | Cir | | | 0.013 | n/a | 312.52 | 0.71 | 0.00 | 2.25 | 0.00 | 24 | 0.00 | 24 | 0.00 | 0.00 | 0.00 | 1.1 | | 0.00 | 0.00 |
| 61.000 | 18 | 0.51 | Cir | | | 0.013 | 0.16 | 373.52 | 0.35 | 0.00 | 0.50 | 0.00 | 18 | 0.00 | 18 | 0.00 | 0.00 | 0.00 | 0.8 | | 0.00 | 0.00 |
| 93.000 | 15 | 0.51 | Cir | | | 0.013 | 0.14 | 466.51 | 0.41 | 0.00 | 2.20 | 0.00 | 15 | 0.00 | 15 | 0.00 | 0.00 | 0.00 | 0.4 | | 0.00 | 0.00 |
| 67.000 | 12 | 0.51 | Cir | | | 0.013 | 0.18 | 533.50 | 0.37 | 0.00 | 2.40 | 0.00 | 12 | 0.00 | 12 | 0.00 | 0.00 | 0.00 | 0.0 | | 0.00 | 0.00 |

| | | |
|---|--------------------|----------------|
| Project File: Gold Dust Storm Drain.stm | Number of lines: 9 | Date: 2/2/2023 |
|---|--------------------|----------------|

NOTES: ** Critical depth

Hydraulic Grade Line Computations

| Line (1) | Size (in) (2) | Q (cfs) (3) | Downstream | | | | | | | | Len (ft) (12) | Upstream | | | | | | | | Check | | JL coeff (K) (23) | Minor loss (ft) (24) |
|-------------|---------------------|-------------------|-------------------------------|----------------------------|----------------------|-----------------------|----------------------|----------------------------|-----------------------------|-------------------|---------------------|--------------------------------|-----------------------------|-----------------------|------------------------|-----------------------|-----------------------------|-----------------------------|-------------------|--------------------------|-------------------------------|----------------------------|-------------------------------|
| | | | Invert elev (ft) (4) | HGL elev (ft) (5) | Depth (ft) (6) | Area (sqft) (7) | Vel (ft/s) (8) | Vel head (ft) (9) | EGL elev (ft) (10) | Sf (%) (11) | | Invert elev (ft) (13) | HGL elev (ft) (14) | Depth (ft) (15) | Area (sqft) (16) | Vel (ft/s) (17) | Vel head (ft) (18) | EGL elev (ft) (19) | Sf (%) (20) | Ave Sf (%) (21) | Enrgy loss (ft) (22) | | |
| 1 | 24 | 9.03 | 1327.00 | 1328.08 | 1.08 | 1.71 | 5.22 | 0.42 | 1328.50 | 0.493 | 93.860 | 1327.47 | 1328.55 | 1.08** | 1.72 | 5.24 | 0.43 | 1328.97 | 0.498 | 0.496 | 0.465 | 0.84 | 0.36 |
| 2 | 24 | 8.39 | 1327.47 | 1328.91 | 1.44 | 1.63 | 3.48 | 0.41 | 1329.32 | 0.000 | 45.000 | 1327.70 | 1328.73 | 1.03** | 1.63 | 5.14 | 0.41 | 1329.14 | 0.000 | 0.000 | n/a | 1.48 | n/a |
| 3 | 24 | 8.38 | 1327.70 | 1328.73 | 1.03 | 1.63 | 5.13 | 0.41 | 1329.14 | 0.000 | 63.000 | 1328.02 | 1329.05 | 1.03** | 1.63 | 5.13 | 0.41 | 1329.46 | 0.000 | 0.000 | n/a | 1.45 | n/a |
| 4 | 24 | 8.37 | 1328.02 | 1329.05 | 1.03 | 1.63 | 5.13 | 0.41 | 1329.46 | 0.000 | 41.000 | 1328.23 | 1329.26 | 1.03** | 1.63 | 5.13 | 0.41 | 1329.67 | 0.000 | 0.000 | n/a | 1.50 | n/a |
| 5 | 24 | 7.67 | 1328.23 | 1329.26 | 1.03 | 1.54 | 4.70 | 0.39 | 1329.65 | 0.000 | 75.000 | 1328.61 | 1329.59 | 0.98** | 1.54 | 4.98 | 0.39 | 1329.98 | 0.000 | 0.000 | n/a | 0.50 | n/a |
| 6 | 24 | 7.35 | 1334.31 | 1335.26 | 0.95* | 1.48 | 4.98 | 0.38 | 1335.64 | 0.000 | 100.000 | 1334.81 | 1335.77 | 0.96** | 1.50 | 4.92 | 0.38 | 1336.15 | 0.000 | 0.000 | n/a | 0.50 | n/a |
| 7 | 18 | 5.10 | 1335.31 | 1336.22 | 0.91* | 1.12 | 4.55 | 0.32 | 1336.54 | 0.507 | 61.000 | 1335.62 | 1336.53 | 0.91 | 1.12 | 4.55 | 0.32 | 1336.85 | 0.507 | 0.507 | 0.309 | 0.50 | 0.16 |
| 8 | 15 | 4.60 | 1335.87 | 1336.90 | 1.03* | 1.08 | 4.26 | 0.28 | 1337.18 | 0.505 | 93.000 | 1336.34 | 1337.37 | 1.03 | 1.08 | 4.26 | 0.28 | 1337.65 | 0.504 | 0.505 | 0.469 | 0.50 | 0.14 |
| 9 | 12 | 2.40 | 1336.59 | 1337.51 | 0.92 | 0.76 | 3.18 | 0.16 | 1337.67 | 0.394 | 67.000 | 1336.93 | 1337.76 | 0.83 | 0.70 | 3.44 | 0.18 | 1337.95 | 0.442 | 0.418 | 0.280 | 1.00 | 0.18 |

Project File: Gold Dust Storm Drain.stm

Number of lines: 9

Run Date: 2/2/2023

Notes: * Normal depth assumed; ** Critical depth. ; c = cir e = ellip b = box

General Procedure:

Hydraflow computes the HGL using the Bernoulli energy equation. Manning's equation is used to determine energy losses due to pipe friction. In a standard step, iterative procedure, Hydraflow assumes upstream HGLs until the energy equation balances. If the energy equation cannot balance, supercritical flow exists and critical depth is temporarily assumed at the upstream end. A supercritical flow Profile is then computed using the same procedure in a downstream direction using momentum principles.

Col. 1 The line number being computed. Calculations begin at Line 1 and proceed upstream.

Col. 2 The line size. In the case of non-circular pipes, the line rise is printed above the span.

Col. 3 Total flow rate in the line.

Col. 4 The elevation of the downstream invert.

Col. 5 Elevation of the hydraulic grade line at the downstream end. This is computed as the upstream HGL + Minor loss of this line's downstream line.

Col. 6 The downstream depth of flow inside the pipe (HGL - Invert elevation) but not greater than the line size.

Col. 7 Cross-sectional area of the flow at the downstream end.

Col. 8 The velocity of the flow at the downstream end, (Col. 3 / Col. 7).

Col. 9 Velocity head (Velocity squared / 2g).

Col. 10 The elevation of the energy grade line at the downstream end, HGL + Velocity head, (Col. 5 + Col. 9).

Col. 11 The friction slope at the downstream end (the S or Slope term in Manning's equation).

Col. 12 The line length.

Col. 13 The elevation of the upstream invert.

Col. 14 Elevation of the hydraulic grade line at the upstream end.

Col. 15 The upstream depth of flow inside the pipe (HGL - Invert elevation) but not greater than the line size.

Col. 16 Cross-sectional area of the flow at the upstream end.

Col. 17 The velocity of the flow at the upstream end, (Col. 3 / Col. 16).

Col. 18 Velocity head (Velocity squared / 2g).

Col. 19 The elevation of the energy grade line at the upstream end, HGL + Velocity head, (Col. 14 + Col. 18) .

Col. 20 The friction slope at the upstream end (the S or Slope term in Manning's equation).

Col. 21 The average of the downstream and upstream friction slopes.

Col. 22 Energy loss. Average $Sf/100 \times \text{Line Length}$ (Col. 21/100 x Col. 12). Equals (EGL upstream - EGL downstream) +/- tolerance.

Col. 23 The junction loss coefficient (K).

Col. 24 Minor loss. (Col. 23 x Col. 18). Is added to upstream HGL and used as the starting HGL for the next upstream line(s).