



GOLD DUST APARTMENTS
Final Water Basis of Design Report
76-PA-2022 (4-ZN-2022
& 2-GP-2022)

Prepared For: ESG Architecture & Design

April 17, 2023



GOLD DUST APARTMENTS

Final Water Basis of Design Report

10050 N Scottsdale Road, Paradise Valley, AZ

76-PA-2022 (4-ZN-2022 & 2-GP-2022)

Prepared For: ESG Architecture & Design
Stephen M. Krager
High Street Residential
2575 East Camelback Road, Suite 400
Phoenix, AZ 85016
P: 602.222.4000

April 17, 2023

Shannon Mauck, PE
Senior Project Manager
1626 N Litchfield Road, Suite 150
Goodyear, AZ 85395
P: 623.935.2258



C. Shannon Mauck

Dibble & Associates Consulting Engineers, Inc., dba Dibble

Table of Contents

1.	INTRODUCTION.....	1
2.	EXISTING CONDITIONS	2
3.	DESIGN CRITERIA.....	2
4.	DESIGN METHODOLOGY	3
4.1	WATER DESIGN	3
4.2	FIRE DESIGN	4
5.	PROPOSED CONDITIONS	4
6.	HYDRAULIC ANALYSIS.....	5
6.1	METHODOLOGY / STUDY APPROACH	5
6.2	RESULTS	5
7.	CONCLUSIONS	6
8.	REFERENCES	6

List of Figures

Figure 1 – VICINITY MAP		1
-------------------------------	--	---

List of Tables

Table 1- DEMAND ALLOCATION SUMMARY		4
Table 2- PRESSURE REQUIREMENTS		6

List of Equations

Equation 1 – AVERAGE DAILY DEMAND.....		3
Equation 2 – MAXIMUM DAILY DEMAND		3
Equation 3 – PEAK HOUR DEMAND		3

Appendices

Appendix A – ZONING MAPS.....		A
Appendix B – PRESSURE ZONE MAP		B
Appendix C - 2021 IFC TABLE B105.1(2)		C
Appendix D – EXISTING UTILITY EXHIBIT		D
Appendix E – UTILITY EXHIBIT		E
Appendix F – FIRE FLOW TEST RESULTS.....		F
Appendix G – WATER DEMAND CALCULATIONS		G
Appendix H – EPANET MODEL CALCULATIONS		H



1. INTRODUCTION

This report presents a final water plan for the City of Scottsdale as a part of the Gold Dust Apartments project. The purpose of this report is to provide analysis and results for the existing and proposed water distribution system at the site. The Gold Dust Apartments site has 215 units of residential use and 7,500 square feet of nonresidential use. The project site is approximately 4.2 acres. The existing site has a fully developed one-story commercial development that will be demolished. The Gold Dust Apartments project includes the design of a new mixed-use building, associated utilities, and hardscape improvements. This report provides the on-site water and fire line analysis and results for the project.

The project is located at the intersection of Gold Dust Ave. and Scottsdale Road, in the northeast quadrant of Township 3 North, Range 4 East, Section 27. This site is bounded by two existing buildings to the east, residential apartments to the west, Acacia Dr to the south, and Gold Dust Ave to the north. This site has an Assessor’s Parcel Number (APN) of 175-56-002H. Located at 10050 N. Scottsdale Road, Paradise Valley, AZ. See **Figure 1** for a location map.

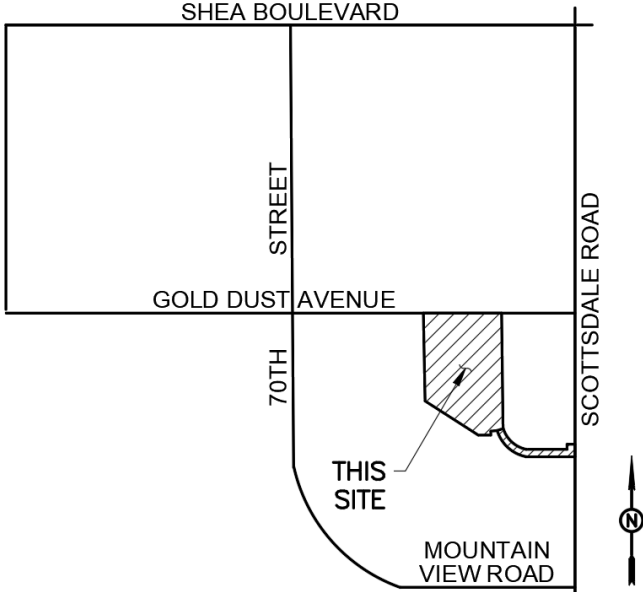

OVERALL DEVELOPMENT
NOT TO SCALE

Figure 1 – VICINITY MAP

2. EXISTING CONDITIONS

The Gold Dust Apartments is located on the southwest corner of the intersection of N Scottsdale Road and E Gold Dust Ave. This project lies on approximately 4.2 acres of fully developed land with an existing shopping center and parking lot. This project is currently zoned PUD per the City of Scottsdale zoning maps. See **Appendix A** for city zoning maps. The Gold Dust Apartments project is contained within Pressure Zone 2 from the City of Scottsdale pressure zone map. See **Appendix B** for the city pressure zone map.

There is a 12-inch ACP water main that runs in N. Scottsdale Road and a 12-inch ACP water main that runs under the sidewalk just south of E. Gold Dust Avenue. There is an 8-inch public main that routes around the entire existing building and through the east side parking lot. This water line is tied into the existing 12-inch ACP water lines that run through N. Scottsdale Road and the 12-inch ACP water main that runs through the sidewalk just south of Gold Dust Avenue. Existing water meters on site are to be removed. See **Appendix D** for the existing water exhibit for locations of all removed water meters. The adjacent roadways are fully developed on site and are not expected to have improvements. There are 2 existing fire hydrants on the site, one existing on the north end of the site along Gold Dust Ave and the second one is on the south side of the existing building.

A fire flow test taken was conducted on March 29th, 2022, to determine the flow and pressure in the existing water distribution system. The results found in **Appendix F** show the existing system meets current fire flow requirements. Section 4.2 addresses the fire flow requirements for the Gold Dust Apartments project.

3. DESIGN CRITERIA

All new public water mains will be submitted to the City of Scottsdale and Maricopa County Environmental Service Division for review. New water mains and services at the site will be designed to meet City of Scottsdale *Design Standards and Policies Manual (2018)*, Maricopa Association of Governments (MAG) standards and details, *Arizona Administrative Code (AAC) Title 18, Arizona Department of Environmental Quality (ADEQ) Bulletins 8 and 10*, and the *2021 International Fire Code (IFC)*. Key design criteria include the following:

- Water distribution lines shall be between 6 and 12-inches in diameter.
- Pipe material shall be ductile iron pipe (DIP) with a pressure class of 350 and polyethylene encasement (polywrap).
- The city does not allow 10-inch, 14-inches, or 18-inch water lines for new construction.
- The use of American Water Works Association (AWWA) C-900 polyvinyl chloride pipe (PVC) is prohibited in the Scottsdale public water system.
- Fire line services 4-inches and larger shall be constructed of DIP class 350.
- All DIP water lines are to be specified with polyethylene wrapping.
- To provide appropriate water pressure, water circulation and redundancy, all new water mains must be designed in a looped configuration.
- All water mains must maintain a 1-foot vertical clearance to dry utilities. Water mains above sewer mains shall maintain 1 to 2 feet of vertical separation with extra protection, greater than 2 feet of separation with no protection. Water mains below sewer mains shall maintain a minimum of 2 feet of vertical separation and always require protection.
- Static pressure in the distribution system shall not exceed 120 pounds per square-inch (psi) and have a minimum of 50 psi at the highest finished floor elevation.
- The system shall be designed to maintain 30 psi minimum pressure at the hydrant tee/tap under design fire flow requirements.
- A domestic service pressure of 15 psi must also be simultaneously maintained at the highest finished floor.

- A minimum cover of 36 inches shall be maintained over lines smaller than 12 inches in diameter, 48 inches of cover shall be maintained over 12-inch lines, and 60 inches of cover shall be maintained over lines larger than 12 inches in diameter.
- All new commercial, industrial, parking area structures, and multi-family residential structures require building sprinkler systems.

4. DESIGN METHODOLOGY

4.1 WATER DESIGN

The City of Scottsdale (*DS&PM*) specifies the design demand for high density condominium inside use as 0.22 gallons per minute (GPM) per unit and an outside use as 0.05 gallons per minute (GPM) per unit. A high-density condominium demand is being used as (*DS&PM*) does not have a specific demand for apartments. The building will also have a co-working space which requires a demand of 0.000695 gallons per minute (GPM) to be used per square foot for inside use and a demand of 0.000139 gallons per minute (GPM) to be used per square foot for outside use. This co-working space demand will be used for the co-work and yoga space. The co-work and yoga space has a total square footage of 7,500 square feet. A maximum day peaking factor of 2.0 and a peak hour peaking factor of 3.5 is used for analysis of the water system per chapter 6-1.404 of the City of Scottsdale *Design Standards and Policies Manual (2018)*.

The Average Day Flow for the facility was calculated with **Equation 1 below**.

Equation 1 – AVERAGE DAILY DEMAND

$$Q_{Avg} = \frac{\# \text{ units or SF}}{1} * \frac{\# \text{ gal}}{\text{unit}}$$

The Maximum Day Flow was calculated with **Equation 2 below**.

Equation 2 – MAXIMUM DAILY DEMAND

$$Q_{max} = Q_{Avg} * (PHF) = Q_{Avg} * 2.0$$

The Peak Day Flow was calculated with **Equation 3 below**.

Equation 3 – PEAK HOUR DEMAND

$$Q_{peak} = Q_{Avg} * (PHF) = Q_{Avg} * 3.5$$

Refer to **Table 1** for potable water demand calculations.



Table 1- DEMAND ALLOCATION SUMMARY

Development Water Demand (Indoor Use)					
Land Use	Number of Units or SF	GPM	Average Day Demand	Maximum Day Demand	Peak Hour Demand
			<i>GPM</i>	<i>GPM</i>	<i>GPM</i>
Apartments	215	0.22	47.30	94.60	165.55
Cowork and Yoga	7,500	0.000695	5.21	10.43	18.24
Development Water Demand (Outdoor Use)					
Land Use	Number of Units or SF	GPM	Average Day Demand	Maximum Day Demand	Peak Hour Demand
			<i>GPM</i>	<i>GPM</i>	<i>GPM</i>
Apartments	215	0.05	10.75	21.50	37.63
Cowork and Yoga	7,500	0.000139	1.04	2.09	3.65
Total Irrigation Flow			11.79	23.59	41.28

4.2 FIRE DESIGN

The *International Fire Code (2021)*, adopted by the City of Scottsdale, specifies required fire flow demands based on Table B105.1(2) and Table B105.2 in **Appendix C**. The Gold Dust Apartments Building is 384,995 SF and of Type V-A wood frame construction over Type 1A parking. Per IFC 2021, The required fire flow for the site is 8,000 GPM, which can be reduced by 75% due to the building being sprinkled to no less than 2,000 GPM. Therefore, the building fire flow requirement is reduced to 2,000 GPM.

The City of Scottsdale *Design Standards and Policies Manual (2018)* requires fire hydrant spacing to be located within 600 feet of a fire hydrant as measured along the accessible fire routes. This spacing applies to interior, on-site fire lane locations for hydrants, as well as to locations along public rights-of-way or private street tracts.

5. PROPOSED CONDITIONS

As part of the proposed site improvements, the existing 8-inch water service line that routes around the entirety of the existing building will have most of the line removed. Parts of the 8-inch water main that runs through the east side parking lot will remain to tie into the new proposed 8-inch water main. See attached **Appendix E** utility exhibit labeled, “new 8” water main” for reference. This new 8-inch DIP water main will run from the 12-inch ACP public water main in Gold Dust Avenue to the existing 8” DIP main that runs between the CVS and California Kitchen. A 1-inch irrigation line will be added on the existing 12-inch water main that runs under Gold Dust Avenue. A 4-inch domestic water service connection and an 8-inch fire service connection will also be added on the existing 12-inch water main that runs under Gold Dust Avenue to serve the Gold Dust Apartments. A new fire hydrant will be provided on the east side of the building of the site to provide building fire protection. The finished floor of the new proposed building is found to be 1344.50 feet. The tallest residential floor was found to be 22 feet above finished floor elevation. The tallest residential floor is at an elevation of 1366.50 feet.

6. HYDRAULIC ANALYSIS

6.1 METHODOLOGY / STUDY APPROACH

Water system demands for the Gold Dust Apartments are calculated based on the specified design demands from the City of Scottsdale, discussed in **Section 4.1.3**. Four hydraulic scenarios, including the average daily demand, peak hour demand, max daily demand plus fire flow demand, and the initial service line design flow, were modeled according to the City of Scottsdale *Design Standards and Policies Manual (DS&PM) (2018)*. Model scenarios 1-3 used the demands calculated in **Appendix G**. Model scenario 4 used the water meter demand calculated from the total fixture units provided by the MEP engineer. Each scenario also has an irrigation demand that is taken from table 1. The scenarios were modeled in EPANET 2.2 to determine if adequate pressure is provided in the water system, and their minimum requirements are outlined below:

Model Scenario 1: Average Day Demand

- 52.51 GPM applied at demand node 17 (average day)
- 11.79 GPM applied at demand node 21 (irrigation)
- Minimum 50 psi at finished floor per City of Scottsdale *DS&PM*

Model Scenario 2: Peak Hour Demand

- 183.79 GPM applied at demand node 17 (peak hour)
- 41.28 GPM applied at demand node 21 (irrigation)
- Minimum 50 psi at finished floor per City of Scottsdale *DS&PM*

Model Scenario 3: Maximum Day Demand plus the Worst-case Fire Flow Demand

- 105.03 GPM applied at demand node 17 (max day)
- 2,000 GPM applied at demand node 26 (worst case hydrant)
- 23.59 GPM applied at demand node 21 (irrigation)
- Minimum 30 psi at hydrant supply line and 15 psi at all domestic demand nodes per City of Scottsdale *DS&PM*.

Model Scenario 4: Initial Service Line Design Flow

- The MEP Engineer provided total fixture units for the water meter at 2,160 total fixture units.
- 41.28 GPM applied at demand node 21 (irrigation)
- 356.2 GPM X 1.5 safety factor, 534.3 GPM applied at node 17 (initial service line)
- Minimum 50 psi at highest floor per City of Scottsdale *DS&PM*

An elevation of 22 feet above the finished floor elevation was used. An estimated minor loss coefficient was used to determine the losses throughout the building. Using the total number of water fixtures and table E103.3(2) from the 2021 International Plumbing Code the demand was found for the initial service line design flow scenario. This demand was found to be 346.2 GPM. A safety factor of 10 gpm was added to account for either a hose bib or a single irrigation sprinkler zone or estimate a higher applicable intermittent or constant base flow. Lastly, a safety factor of 1.5 was added to the resultant total flow to obtain the Initial Service Design Flow. This gave a final demand total for the Initial Service Design Flow of 534.3 GPM.

6.2 RESULTS

Appendix H includes the EPANET 2.2 model water model results for the three model scenarios described in **Section 6.1** as well as a static condition with no demands applied. **Table 2** shows the City's minimum requirements compared to the lowest pressures outputted from the water model (see **Appendix H**).

Table 2- PRESSURE REQUIREMENTS

Scenario	Minimum City Pressure Requirement for Finished Floor and Building Fire Lines [psi]	Lowest Modeled Pressure [psi]	Pressure at Building Connection Point [psi]
1	50	86.18	92.65
2	50	76.55	90.91
3	30 (hydrant supply line) 15 (all demand nodes)	64.82	81.12
4	50 (highest floor)	75.73	81.2 (at highest floor-elevation)

Model Scenarios 1 through 3 meet the City of Scottsdale Standards by maintaining the minimum pressures required for each scenario at the finished floor. The lowest pressure in scenario 1 was 86.18 and in scenario 2 it was 76.55 psi. The lowest pressure for Scenario 3 was 64.82. All of these lowest pressures are at node 21. This is due to the presence of the PRV near node 21, where the pressure is regulated to be 50 psi.

The City of Scottsdale *Design Standards and Policies Manual (2018)* requires the maximum allowable pipe head loss in transmission mains to be eight feet per 1,000 feet and ten feet per 1,000 feet in distribution lines. The water mains in all scenarios meets these requirements.

7. CONCLUSIONS

The proposed water system will support the development of the new Gold Dust Apartment project while adhering to City of Scottsdale design standards. The highest modeled pressures in the water system are experienced at the connection of the irrigation line and the domestic water line due to the PRV's being attached to these lines. All pressures are within City of Scottsdale requirements.

The fire flow test shows that the existing infrastructure with the proposed water developments will be able to support the flow and pressure demands of the proposed Gold Dust apartment building while meeting City of Scottsdale and Fire Code requirements. The fire flow test accounted for 6,239 gallons per minute of water at 20 psi and 4,942 gallons per minute with a 28 PSI safety factor. The Gold Dust Apartments fire flow demand is only 2,000 gallons per minute. The fire flow test can be found in **Appendix F**. The hydrants serviced the existing development, so there are no expected issues with flows or pressures within the area. A final model will be provided in the final report.

8. REFERENCES

City of Scottsdale. Design Standards and Policies Manual, 2018.

International Code Council. International Fire Code, 2021.

Maricopa Association of Governments. Uniform Standard Details for Public Works Construction, 2021.

Arizona Administrative Code (AAC) Title 18, September 2016.

Arizona Department of Environmental Quality (ADEQ) Bulletins 8 and 10, July 1978.

International Code Council. International Plumbing Code 2021.



Appendix A – ZONING MAPS

1,922 records

-
-
-
-

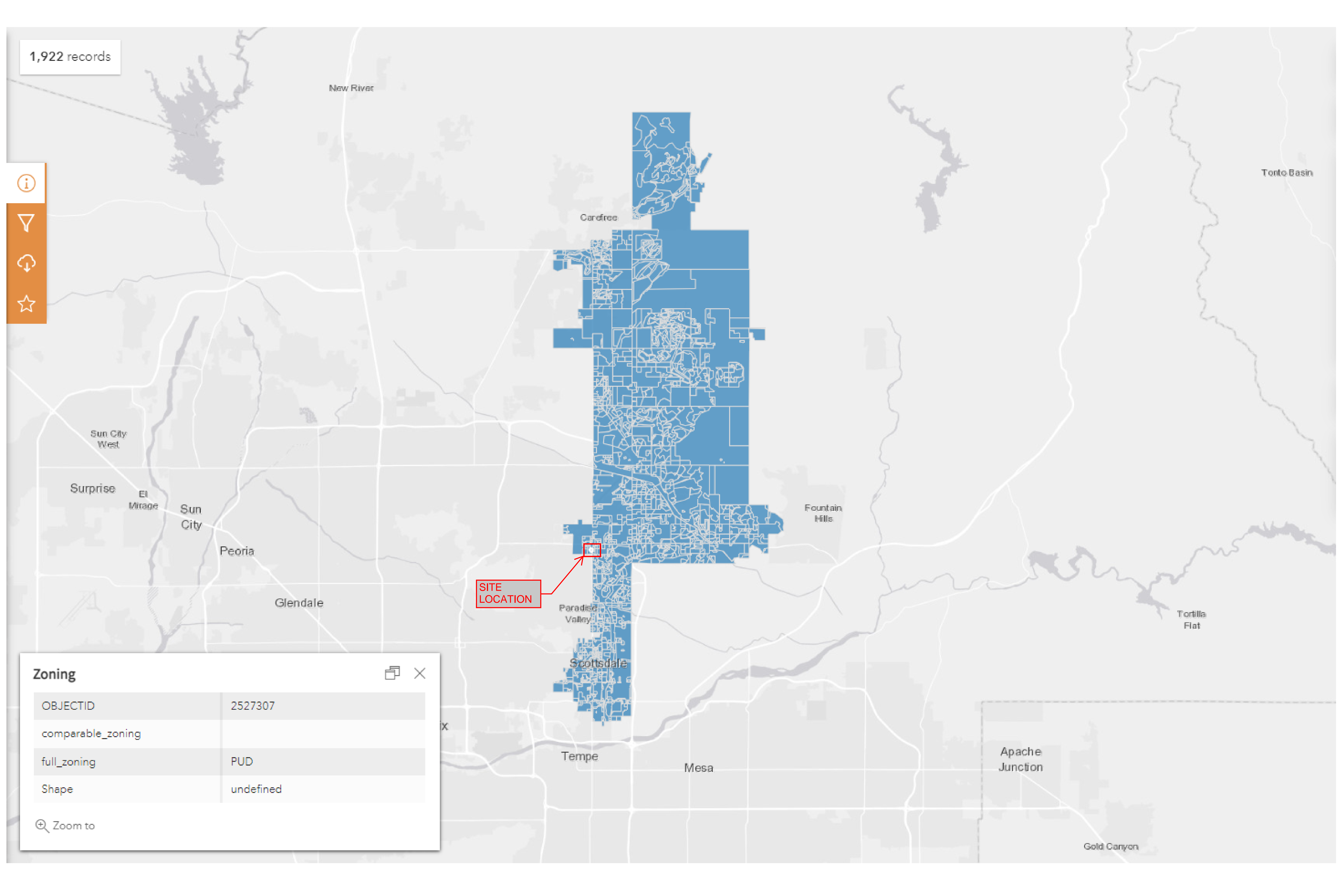

Zoning

OBJECTID	2527307
comparable_zoning	
full_zoning	PUD
Shape	undefined

Zoom to

1,922 records

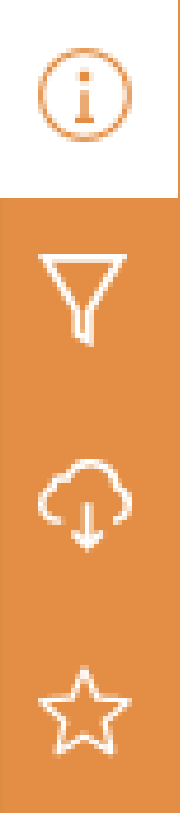

SITE LOCATION

Zoning [Close] [Copy]

OBJECTID	2527307
comparable_zoning	
full_zoning	PUD
Shape	undefined

🔍 Zoom to

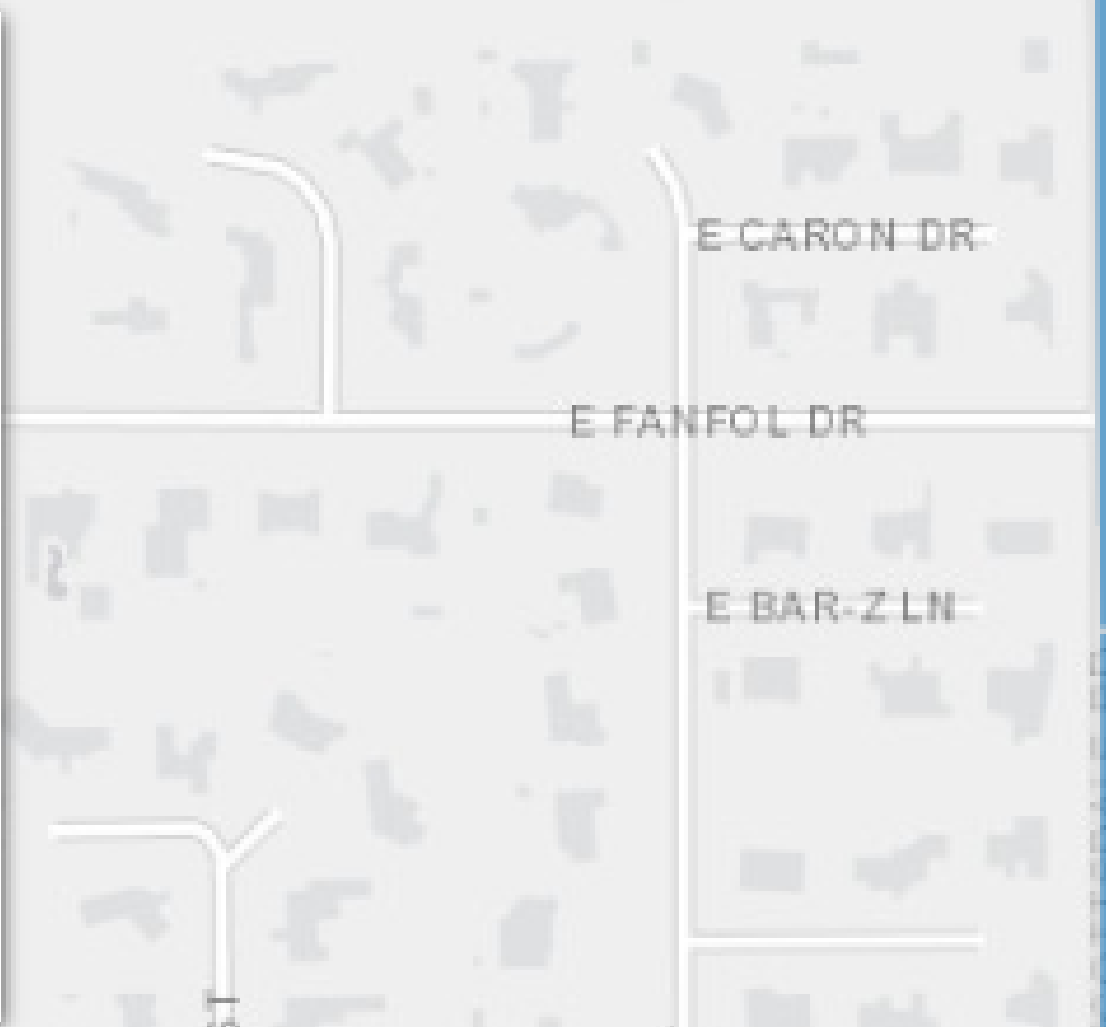



Appendix B – PRESSURE ZONE MAP

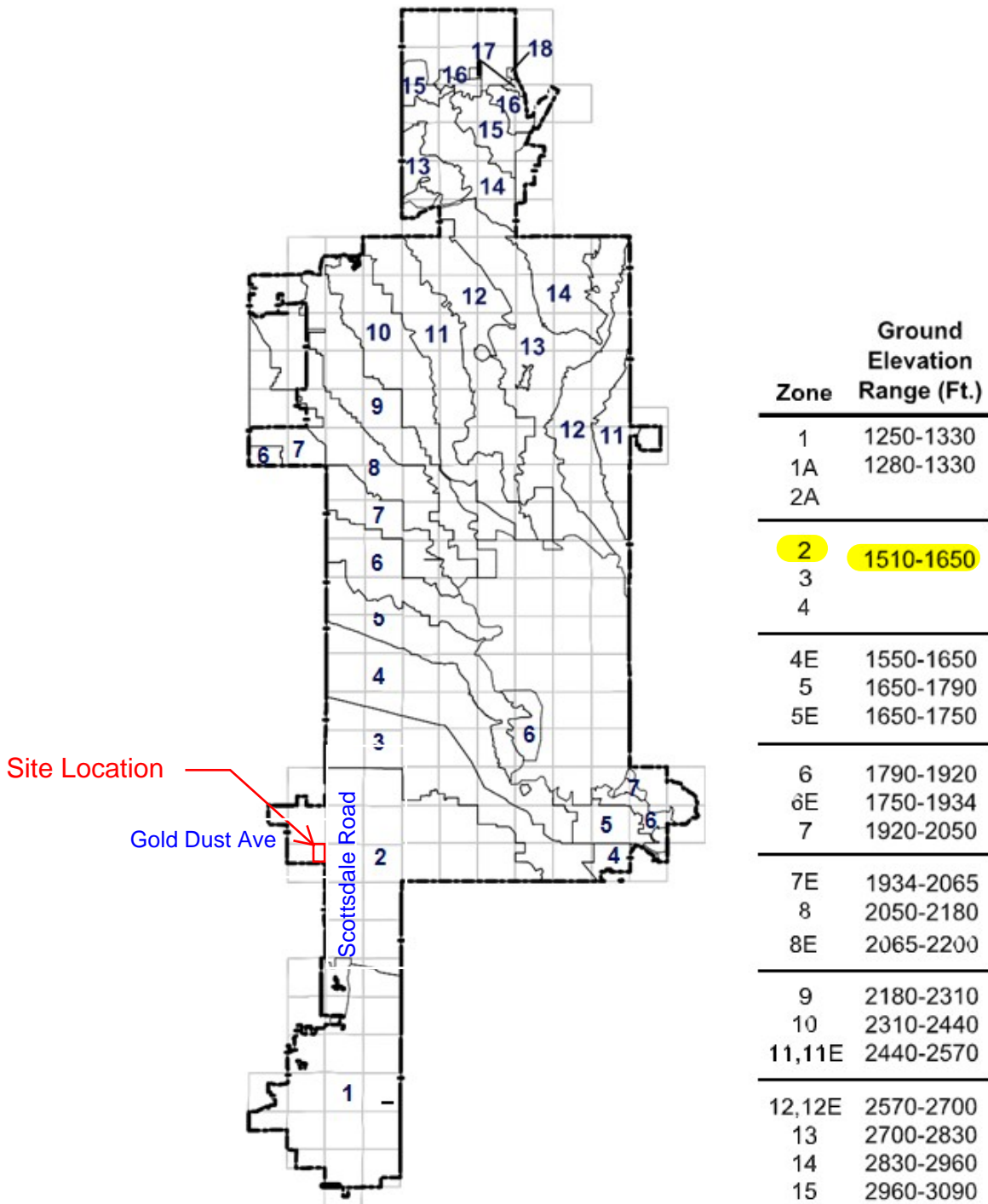

6-1.3 CITY PRESSURE ZONE MAP

6-1.300



Appendix C - 2021 IFC TABLE B105.1(2)

TABLE B105.1(2)
REFERENCE TABLE FOR TABLES B105.1(1) AND B105.2

FIRE-FLOW CALCULATION AREA (square feet)					FIRE-FLOW (gallons per minute) ^b	FLOW DURATION (hours)
Type IA and IB ^a	Type IIA and IIIA ^a	Type IV and V-A ^a	Type IIB and IIIB ^a	Type V-B ^a		
0-22,700	0-12,700	0-8,200	0-5,900	0-3,600	1,500	2
22,701-30,200	12,701-17,000	8,201-10,900	5,901-7,900	3,601-4,800	1,750	
30,201-38,700	17,001-21,800	10,901-12,900	7,901-9,800	4,801-6,200	2,000	
38,701-48,300	21,801-24,200	12,901-17,400	9,801-12,600	6,201-7,700	2,250	
48,301-59,000	24,201-33,200	17,401-21,300	12,601-15,400	7,701-9,400	2,500	
59,001-70,900	33,201-39,700	21,301-25,500	15,401-18,400	9,401-11,300	2,750	
70,901-83,700	39,701-47,100	25,501-30,100	18,401-21,800	11,301-13,400	3,000	3
83,701-97,700	47,101-54,900	30,101-35,200	21,801-25,900	13,401-15,600	3,250	
97,701-112,700	54,901-63,400	35,201-40,600	25,901-29,300	15,601-18,000	3,500	
112,701-128,700	63,401-72,400	40,601-46,400	29,301-33,500	18,001-20,600	3,750	
128,701-145,900	72,401-82,100	46,401-52,500	33,501-37,900	20,601-23,300	4,000	4
145,901-164,200	82,101-92,400	52,501-59,100	37,901-42,700	23,301-26,300	4,250	
164,201-183,400	92,401-103,100	59,101-66,000	42,701-47,700	26,301-29,300	4,500	
183,401-203,700	103,101-114,600	66,001-73,300	47,701-53,000	29,301-32,600	4,750	
203,701-225,200	114,601-126,700	73,301-81,100	53,001-58,600	32,601-36,000	5,000	
225,201-247,700	126,701-139,400	81,101-89,200	58,601-65,400	36,001-39,600	5,250	
247,701-271,200	139,401-152,600	89,201-97,700	65,401-70,600	39,601-43,400	5,500	
271,201-295,900	152,601-166,500	97,701-106,500	70,601-77,000	43,401-47,400	5,750	
295,901-Greater	166,501-Greater	106,501-115,800	77,001-83,700	47,401-51,500	6,000	
—	—	115,801-125,500	83,701-90,600	51,501-55,700	6,250	
—	—	125,501-135,500	90,601-97,900	55,701-60,200	6,500	
—	—	135,501-145,800	97,901-106,800	60,201-64,800	6,750	
—	—	145,801-156,700	106,801-113,200	64,801-69,600	7,000	
—	—	156,701-167,900	113,201-121,300	69,601-74,600	7,250	
—	—	167,901-179,400	121,301-129,600	74,601-79,800	7,500	
—	—	179,401-191,400	129,601-138,300	79,801-85,100	7,750	
—	—	191,401-Greater	138,301-Greater	85,101-Greater	8,000	

For SI: 1 square foot = 0.0929 m², 1 gallon per minute = 3.785 L/m, 1 pound per square inch = 6.895 kPa.

- a. Types of construction are based on the *International Building Code*.
- b. Measured at 20 psi residual pressure.



Appendix D – EXISTING UTILITY EXHIBIT



500 Washington Avenue South, Suite 1080
Minneapolis, MN 55415
p 612.339.5508 | f 612.339.5382
www.esgarch.com

I hereby certify that this plan, specification, or report was prepared by me or under my direct supervision and that I am a duly licensed architect under the laws of the State of Arizona

Signature _____
Typed or Printed Name _____
License # _____ Date _____

**DRB
SUBMITTAL
2/02/2023**

ORIGINAL ISSUE:
REVISIONS
No. Description Date

221564
PROJECT NUMBER
DRAWN BY _____ CHECKED BY _____

KEY PLAN

Gold Dust Ave &
Scottsdale Rd

Existing Utility
Exhibit
1.0

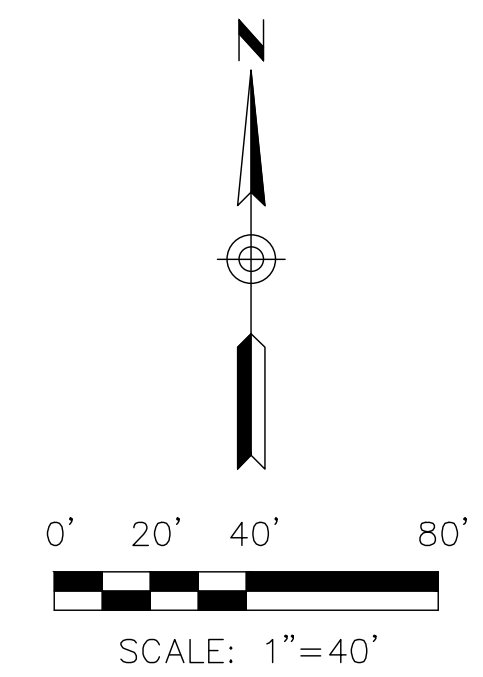
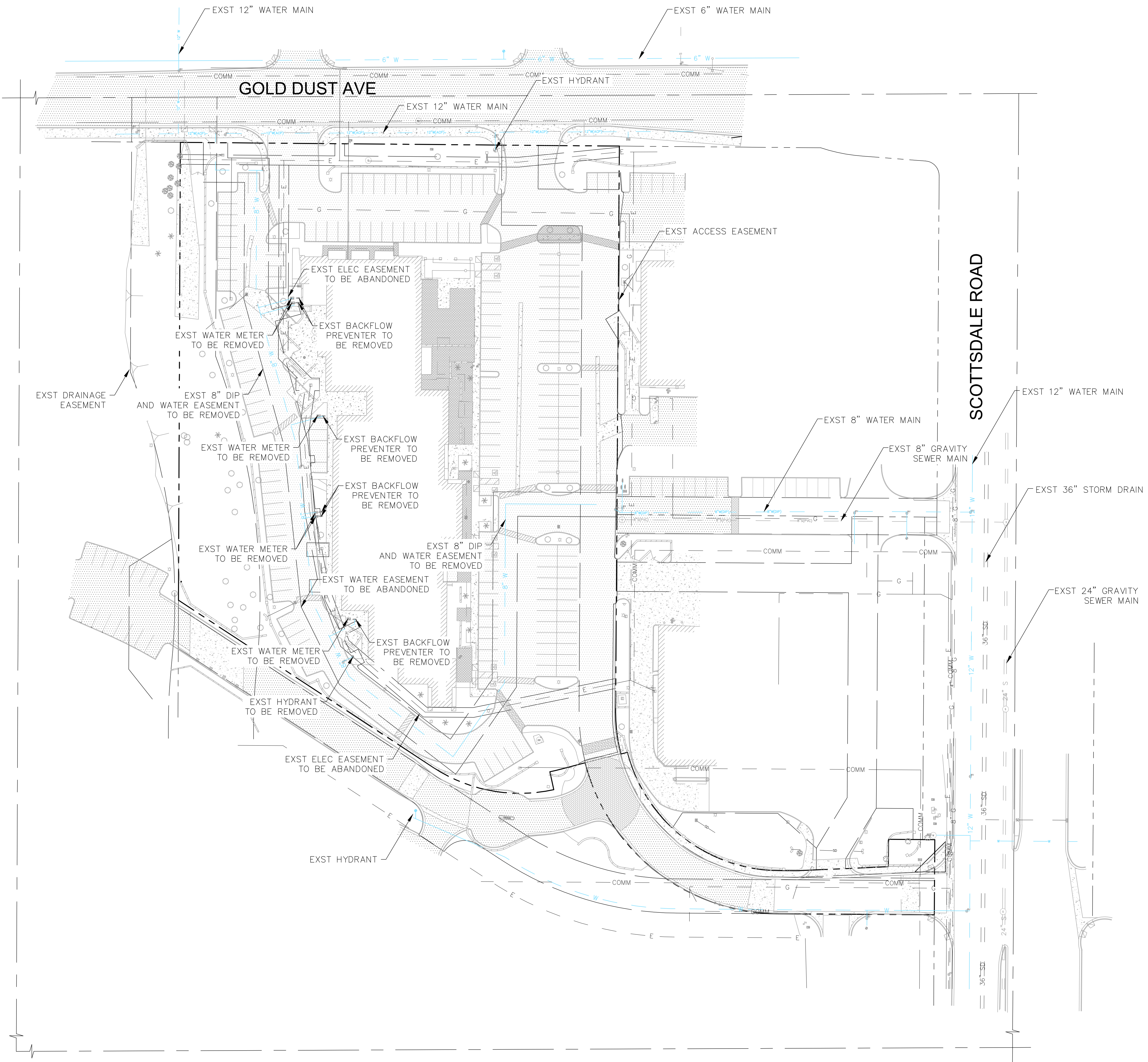



Appendix E – UTILITY EXHIBIT



500 Washington Avenue South, Suite 1080
Minneapolis, MN 55415
p 612.339.5508 | f 612.339.5382
www.esgarch.com

I hereby certify that this plan, specification, or report was prepared by me or under my direct supervision and that I am a duly licensed architect under the laws of the State of Arizona

Signature _____
Typed or Printed Name _____
License # _____ Date _____

**DRB
RE-SUBMITTAL
04/17/2023**

ORIGINAL ISSUE:
REVISIONS
No. Description Date

221564
PROJECT NUMBER
DRAWN BY _____ CHECKED BY _____

KEY PLAN

Gold Dust Ave &
Scottsdale Rd

Proposed Utility
Exhibit
1.0

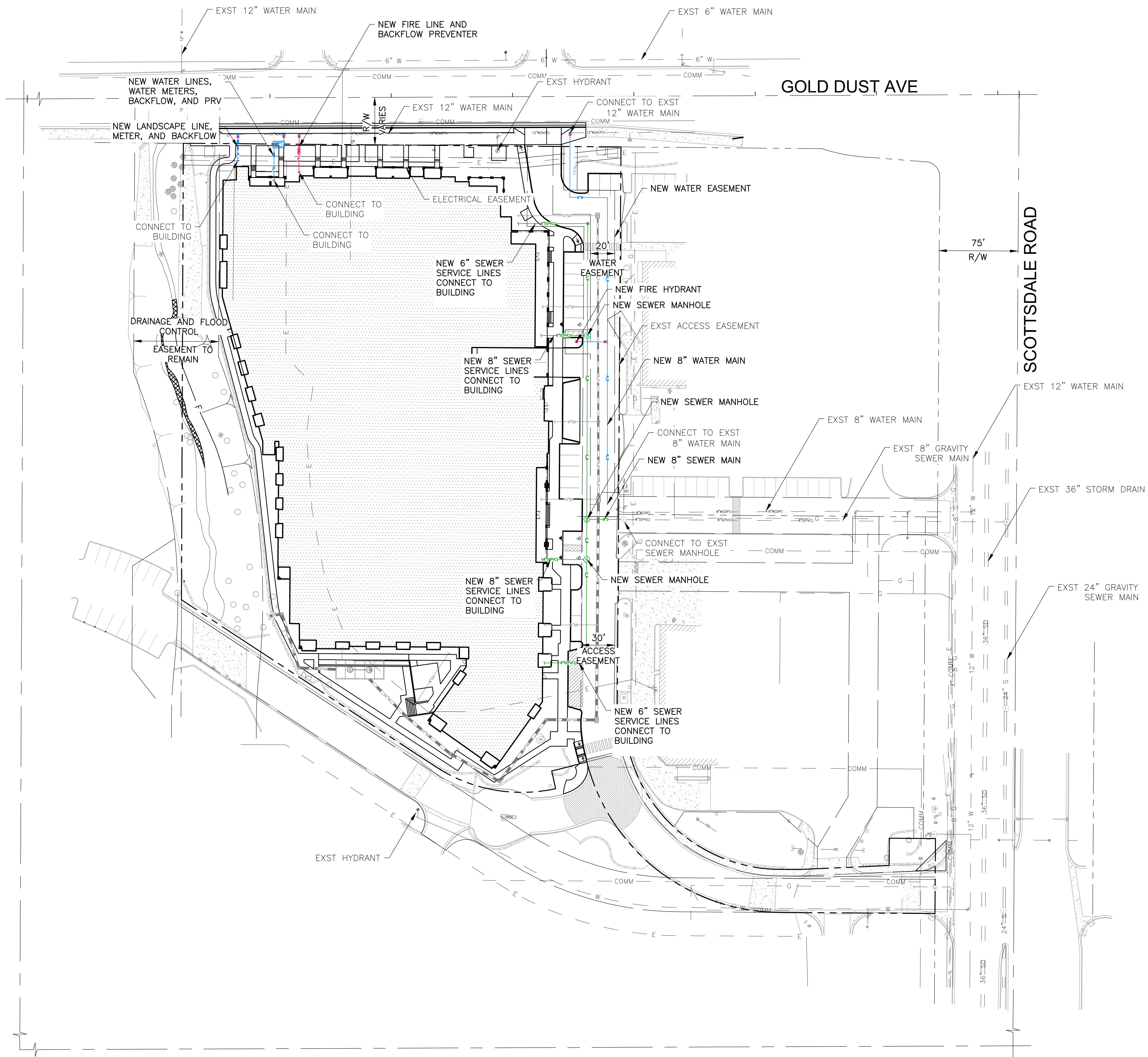

NOTE:
1. ALL UTILITY CROSSINGS WILL REQUIREMENTS WILL BE MET PER THE STANDARDS SET FORTH BY THE CITY OF SCOTTSDALE.

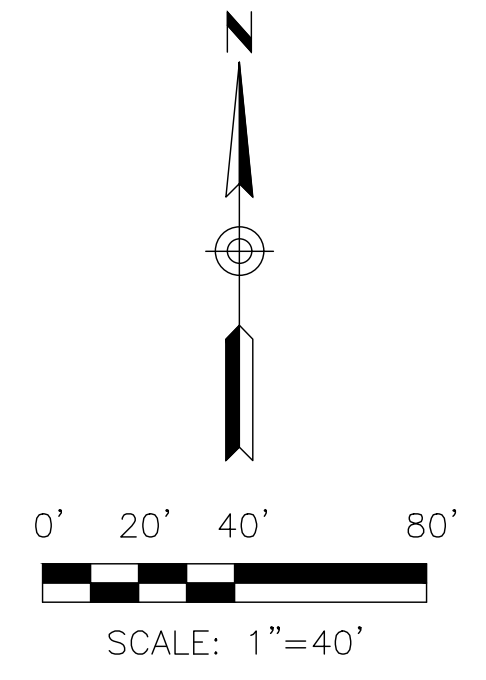



Appendix F – FIRE FLOW TEST RESULTS

Arizona Flow Testing LLC

HYDRANT FLOW TEST REPORT

Project Name: Gold Dust and Scottsdale
Project Address: 10060 North Scottsdale Road, Scottsdale, Arizona, 85253
Client Project No.: Not Provided
Arizona Flow Testing Project No.: 22177
Flow Test Permit No.: C68299
Date and time flow test conducted: March 29, 2022 at 6:50 AM
Data is current and reliable until: September 29, 2022
Conducted by: Floyd Vaughan – Arizona Flow Testing, LLC (480-250-8154)
Witnessed by: Vince Cusumano – City of Scottsdale-Inspector (602-828-0847)

Raw Test Data

Static Pressure: **100.0 PSI**
(Measured in pounds per square inch)

Residual Pressure: **54.0 PSI**
(Measured in pounds per square inch)

Pitot Pressure: **27.0 PSI Hyd A**
31.0 PSI Hyd B
(Measured in pounds per square inch)

Diffuser Orifice Diameter: Two 4-inch Pollard Diffuser
(Measured in inches)

Coefficient of Diffuser: 0.9

Flowing GPM: **4,625 GPM**
(Measured in gallons per minute)
2,233 GPM + 2,392 GPM = 4,625 GPM

GPM @ 20 PSI: **6,239 GPM**

Data with 28 PSI Safety Factor

Static Pressure: **72.0 PSI**
(Measured in pounds per square inch)

Residual Pressure: **26.0 PSI**
(Measured in pounds per square inch)

Distance between hydrants: See Below

Main size: Not Provided

Flowing GPM: **4,625 GPM**

GPM @ 20 PSI: **4,942 GPM**

Scottsdale requires a maximum Static Pressure of 72 PSI for AFES Design.

Flow Test Location

North ↑

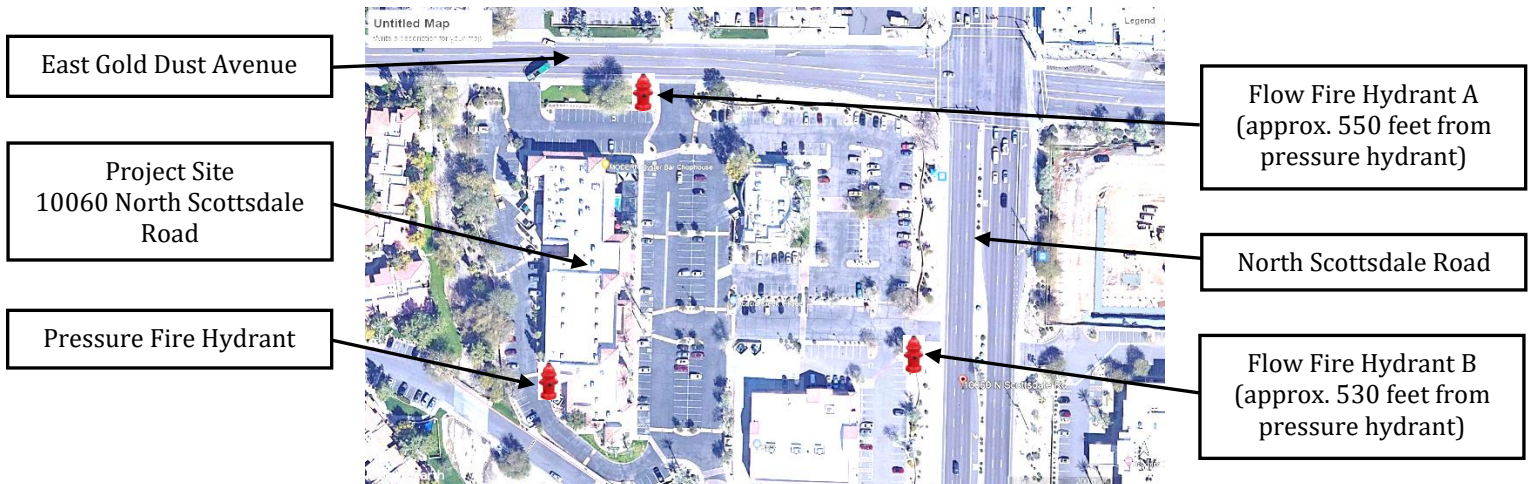



Appendix G – WATER DEMAND CALCULATIONS



GOLD DUST APARTMENTS
DIBBLE PROJECT NO. 1122028
WATER DEMAND CALCULATIONS

DES: KJR

DATE: 2023-0125

DEVELOPMENT WATER DEMAND IN GALLONS PER MINUTE (INDOOR USE)

LAND USE	NUMBER OF UNITS	NUMBER OF SF	DEMAND [GPM/UNIT]	AVERAGE DEMAND [GPM]	MA X DAY DEMAND [GPM]	PEAK HOUR DEMAND [GPM]
APARTMENTS	215		0.22	47.30	94.60	165.55
COWORK AND YOGA		7,500	0.000695	5.21	10.43	18.24
TOTAL INDOOR FLOW				52.51	105.03	183.79

DEVELOPMENT WATER DEMAND IN GALLONS PER MINUTE (OUTDOOR USE)

LAND USE	NUMBER OF UNITS	NUMBER OF SF	DEMAND [GPM/UNIT]	AVERAGE DEMAND [GPM]	MA X DAY DEMAND [GPM]	PEAK HOUR DEMAND [GPM]
APARTMENTS	215		0.05	10.75	21.50	37.63
COWORK AND YOGA		7,500	0.000139	1.04	2.09	3.65
TOTAL FLOW IRRIGATION				11.79	23.59	41.27



Appendix H – EPANET MODEL CALCULATIONS

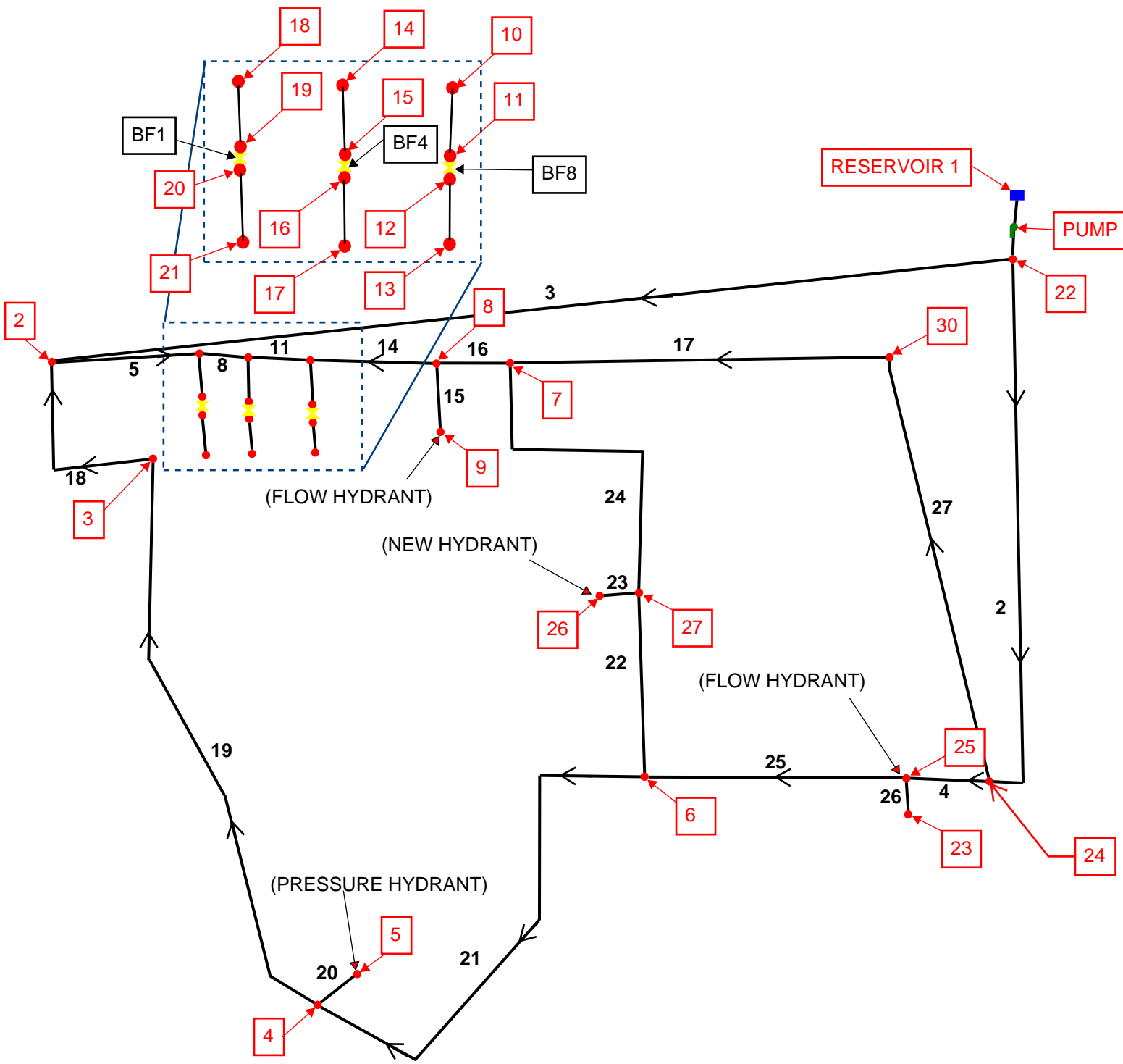

MODEL MAP GOLD DUST APARTMENTS

EPANET 2.2



 * E P A N E T *
 * Hydraulic and Water Quality *
 * Analysis for Pipe Networks *
 * Version 2.0 *

Input File: Gold Dust Apartments

Static Condition

Network Table - Links:

Link ID	Length ft	Diameter in	Roughness	Flow Rate gpm	Velocity ft/sec	Unit Headloss ft/Kft	Status
Pipe 18		64	8	140	0	0	Closed
Pipe 19		415	8	140	0	0	Closed
Pipe 20		10	6	140	0	0	Closed
Pipe 21		410	8	140	0	0	Closed
Pipe 16		60	12	140	0.01	0	Open
Pipe 14		163	12	140	0.01	0	Open
Pipe 11		13	12	140	0.01	0	Open
Pipe 8		38	12	140	0.01	0	Open
Pipe 5		16	12	140	0.01	0	Open
Pipe 6		10	1	140	0	0	Open
Pipe 7		12	1	140	0	0	Open
Pipe 9		19	4	140	0	0	Open
Pipe 10		23	4	140	0	0	Open
Pipe 12		10	8	140	0	0	Open
Pipe 13		21	8	140	0	0	Open
Pipe 15		15	6	140	0	0	Open
Pipe 25	263.40	8	140	0.05	0	0	Open
Pipe 26	22	6	140	0	0	0	Open
Pipe 24	202	8	140	0.05	0	0	Open
Pipe 22	134	8	140	0.05	0	0	Open
Pipe 23	12	6	140	0	0	0	Open
Pipe 17	396	12	140	-0.06	0	0	Open
Pipe 3	1	100	140	-0.01	0	0	Open
Pipe 27	375.5	12	140	0.06	0	0	Open
Pipe 4	54	8	100	0.05	0	0	Open
Pipe 2	1	100	140	-0.01	0	0	Open
Pump Pump	#N/A	#N/A	#N/A	0	0	-231	Open
Valve BF1	#N/A	1	#N/A	0	0	29.45	Open
Valve BF4	#N/A	4	#N/A	0	0	16.17	Open
Valve BF8	#N/A	8	#N/A	0	0	8.09	Open

Network Table - Nodes:

Node ID	Elevation	Base Demand GPM	Head ft	Pressure psi
Junc 2	0	0	231	100.09
Junc 3	0	0	231	100.09
Junc 4	0	0	231	100.09
Junc 5	0	0	231	100.09
Junc 6	0	0	231	100.09
Junc 7	0	0	231	100.09
Junc 8	0	0	231	100.09
Junc 9	0	0	231	100.09
Junc 10	0	0	231	100.09
Junc 11	0	0	231	100.09

Junc 12	0	0	222.91	96.59
Junc 13	0	0	222.91	96.59
Junc 14	0	0	231	100.09
Junc 15	0	0	231	100.09
Junc 16	0	0	214.83	93.09
Junc 17	0	0	214.83	93.09
Junc 18	0	0	231	100.09
Junc 19	0	0	231	100.09
Junc 20	0	0	260.45	112.85
Junc 21	0	0	260.45	112.85
Junc 23	0	0	231	100.09
Junc 25	0	0	231	100.09
Junc 26	0	0	231	100.09
Junc 27	0	0	231	100.09
Junc 30	0	0	231	100.09
Junc 22	0	0	231	100.09
Junc 24	0	0	231	100.09
Resvr 1	0	#N/A	0	0

 * E P A N E T *
 * Hydraulic and Water Quality *
 * Analysis for Pipe Networks *
 * Version 2.0 *

Input File: Gold Dust Apartments

Fire Flow Calibration

Network Table - Links:

Link ID	Length ft	Diameter in	Roughness	Flow Rate gpm	Velocity ft/sec	Unit Headloss ft/Kft	Status	
Pipe 18		64	8	140	399.41	2.55	3.38	Open
Pipe 19		415	8	140	399.41	2.55	3.06	Open
Pipe 20		10	6	140	0	0	0	Closed
Pipe 21		410	8	140	399.41	2.55	3.11	Open
Pipe 16		60	12	140	782.13	2.22	1.66	Open
Pipe 14		163	12	140	-1450.87	4.12	4.72	Open
Pipe 11		13	12	140	-1450.87	4.12	8.45	Open
Pipe 8		38	12	140	-1450.87	4.12	5.79	Open
Pipe 5		16	12	140	-1450.87	4.12	7.69	Open
Pipe 6		10	1	140	0	0	0	Open
Pipe 7		12	1	140	0	0	0	Open
Pipe 9		19	4	140	0	0	0	Open
Pipe 10		23	4	140	0	0	0	Open
Pipe 12		10	8	140	0	0	0	Open
Pipe 13		21	8	140	0	0	0	Open
Pipe 15		15	6	140	2233	25.34	4273.52	Open
Pipe 25	263.40		8	140	399.41	2.55	3.14	Open
Pipe 26	22		6	140	2392	27.14	3444.67	Open
Pipe 24	202		8	140	0	0	0	Closed
Pipe 22	134		8	140	0	0	0	Open
Pipe 23	12		6	140	0	0	0	Open
Pipe 17	396		12	140	-782.13	2.22	1.47	Open
Pipe 3	1		100	140	1850.28	0.08	0	Open
Pipe 27	375.5		12	140	782.13	2.22	1.44	Open
Pipe 4	54		8	140	-1992.59	12.72	66.39	Open
Pipe 2	1		100	140	-2774.72	0.11	0	Open
Pump Pump	#N/A	#N/A	#N/A	4625		0	-126	Open
Valve BF1	#N/A	1	#N/A	0		0	29.45	Open
Valve BF4	#N/A	4	#N/A	0		0	16.17	Open
Valve BF8	#N/A	8	#N/A	0		0	8.08	Open

Network Table - Nodes:

Node ID	Elevation	Base Demand GPM	Head ft	Pressure psi	
Junc 2		0	0	126	54.6
Junc 3		0	0	125.78	54.5
Junc 4		0	0	124.52	53.95
Junc 5		0	0	124.52	53.95
Junc 6		0	0	123.24	53.4
Junc 7		0	0	124.88	54.11
Junc 8		0	0	124.78	54.07
Junc 9		0	2233	60.67	26.29
Junc 10		0	0	125.55	54.4
Junc 11		0	0	125.55	54.4

Junc 12	0	0	133.63	57.9
Junc 13	0	0	133.63	57.9
Junc 14	0	0	125.66	54.45
Junc 15	0	0	125.66	54.45
Junc 16	0	0	141.83	61.45
Junc 17	0	0	141.83	61.45
Junc 18	0	0	125.88	54.54
Junc 19	0	0	125.88	54.54
Junc 20	0	0	96.42	41.78
Junc 21	0	0	96.42	41.78
Junc 23	0	2392	46.63	20.21
Junc 25	0	0	122.41	53.04
Junc 26	0	0	123.24	53.4
Junc 27	0	0	123.24	53.4
Junc 30	0	0	125.46	54.36
Junc 22	0	0	126	54.6
Junc 24	0	0	126	54.6
Resvr 1	0	#N/A	0	0

AVG DAY

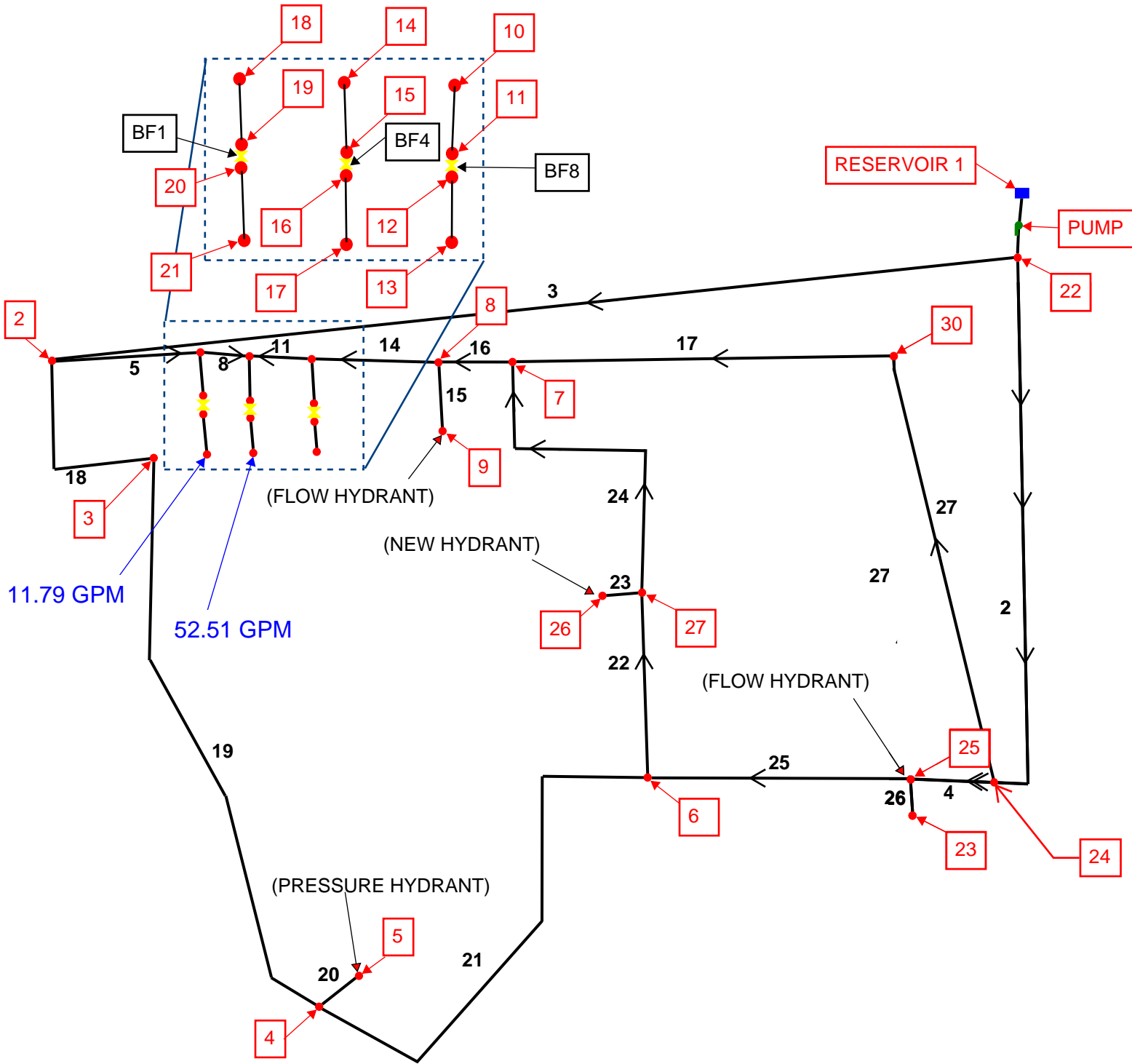

MODEL MAP GOLD DUST APARTMENTS

EPANET 2.2



```

*****
*                                     E P A N E T                                     *
*                                     Hydraulic and Water Quality                             *
*                                     Analysis for Pipe Networks                             *
*                                     Version 2.0                                         *
*****

```

Input File: Gold Dust Apartments

Average Day

Network Table - Links:

Link ID	Length ft	Diameter in	Roughness	Flow Rate gpm	Velocity ft/sec	Unit Headloss ft/Kft	Status	
Pipe 18		64	8	140	0	0	Closed	
Pipe 19		415	8	140	0	0	Closed	
Pipe 20		10	6	140	0	0	Closed	
Pipe 21		410	8	140	0	0	Closed	
Pipe 16		60	12	140	12.66	0.04	Open	
Pipe 14		163	12	140	12.66	0.04	Open	
Pipe 11		13	12	140	12.66	0.04	Open	
Pipe 8		38	12	140	-39.85	0.11	0.01	Open
Pipe 5		16	12	140	-51.64	0.15	0.01	Open
Pipe 6		10	1	140	11.79	4.82	119.62	Open
Pipe 7		12	1	140	11.79	4.82	117.52	Open
Pipe 9		19	4	140	52.51	1.34	2.5	Open
Pipe 10		23	4	140	52.51	1.34	4.84	Open
Pipe 12		10	8	140	0	0	0	Open
Pipe 13		21	8	140	0	0	0	Open
Pipe 15		15	6	140	0	0	0	Open
Pipe 25		263.40	8	140	-3.43	0.02	0	Open
Pipe 26		22	6	140	0	0	0	Open
Pipe 24		202	8	140	-3.43	0.02	0	Open
Pipe 22		134	8	140	-3.43	0.02	0	Open
Pipe 23		12	6	140	0	0	0	Open
Pipe 17		396	12	140	-9.22	0.03	0	Open
Pipe 3		1	100	140	51.64	0	0.02	Open
Pipe 27		375.5	12	140	9.22	0.03	0	Open
Pipe 4		54	8	140	-3.43	0.02	0	Open
Pipe 2		1	100	140	-12.66	0	0.02	Open
Pump Pump		#N/A	#N/A	#N/A	64.3	0	-230.96	Open
Valve BF1		#N/A	1	#N/A	11.79	4.82	29.45	Open
Valve BF4		#N/A	4	#N/A	52.51	1.34	16.98	Open
Valve BF8		#N/A	8	#N/A	0	0	8.08	Open

Network Table - Nodes:

Node ID	Elevation	Base Demand GPM	Head ft	Pressure psi	
Junc 2		0	0	230.96	100.07
Junc 3		0	0	230.96	100.07
Junc 4		0	0	230.96	100.07
Junc 5		0	0	230.96	100.07
Junc 6		0	0	230.96	100.07
Junc 7		0	0	230.96	100.07
Junc 8		0	0	230.96	100.07
Junc 9		0	0	230.96	100.07
Junc 10		0	0	230.96	100.07
Junc 11		0	0	230.96	100.07

Junc 12	0	0	239.04	103.58
Junc 13	0	0	239.04	103.58
Junc 14	0	0	230.96	100.07
Junc 15	0	0	230.91	100.05
Junc 16	0	0	213.93	92.7
Junc 17	0	52.51	213.82	92.65
Junc 18	0	0	230.96	100.07
Junc 19	0	0	229.76	99.56
Junc 20	0	0	200.31	86.79
Junc 21	0	11.79	198.90	86.18
Junc 23	0	0	230.96	100.07
Junc 25	0	0	230.96	100.07
Junc 26	0	0	230.96	100.07
Junc 27	0	0	230.96	100.07
Junc 30	0	0	230.96	100.07
Junc 22	0	0	230.96	100.07
Junc 24	0	0	230.96	100.07
Resvr 1	0	#N/A	0	0

PEAK HR

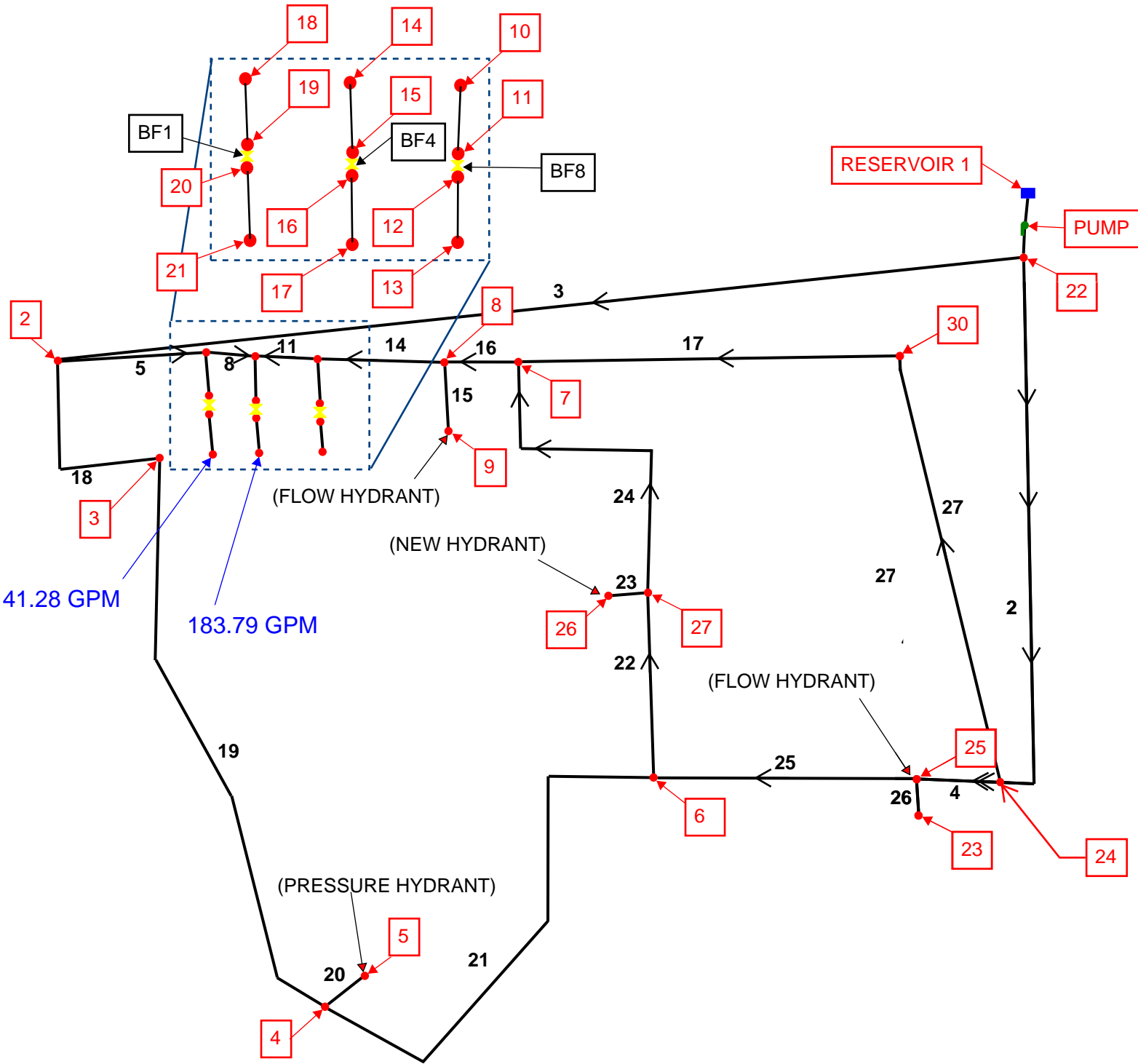

MODEL MAP GOLD DUST APARTMENTS

EPANET 2.2



 * E P A N E T *
 * Hydraulic and Water Quality *
 * Analysis for Pipe Networks *
 * Version 2.0 *

Input File: Gold Dust Apartments

Peak Hour

Network Table - Links:

Link ID	Length ft	Diameter in	Roughness	Flow Rate gpm	Velocity ft/sec	Unit Headloss ft/Kft	Status
Pipe 18		64	8	140	0	0	0 Closed
Pipe 19		415	8	140	0	0	0 Closed
Pipe 20		10	6	140	0	0	0 Closed
Pipe 21		410	8	140	0	0	0 Closed
Pipe 16		60	12	140	44.98	0.13	0.01 Open
Pipe 14		163	12	140	44.98	0.13	0.01 Open
Pipe 11		13	12	140	44.98	0.13	0.01 Open
Pipe 8		38	12	140	-138.81	0.39	0.07 Open
Pipe 5		16	12	140	-180.09	0.51	0.14 Open
Pipe 6		10	1	140	41.28	16.86	1244.31 Open
Pipe 7		12	1	140	41.28	16.86	1218.55 Open
Pipe 9		19	4	140	183.79	4.69	26.52 Open
Pipe 10		23	4	140	183.79	4.69	55.15 Open
Pipe 12		10	8	140	0	0	0 Open
Pipe 13		21	8	140	0	0	0 Open
Pipe 15		15	6	140	0	0	0 Open
Pipe 25	263.40		8	140	-12.18	0.08	0 Open
Pipe 26		22	6	140	0	0	0 Open
Pipe 24		202	8	140	-12.18	0.08	0 Open
Pipe 22		134	8	140	-12.18	0.08	0 Open
Pipe 23		12	6	140	0	0	0 Open
Pipe 17		396	12	140	-32.8	0.09	0 Open
Pipe 3		1	100	140	180.09	0.01	0 Open
Pipe 27	375.5		12	140	32.8	0.09	0 Open
Pipe 4		54	8	140	-12.18	0.08	0.01 Open
Pipe 2		1	100	140	-44.98	0	0 Open
Pump Pump	#N/A	#N/A	#N/A	225.07		0	-230.59 Open
Valve BF1	#N/A		1	#N/A	41.28	16.86	26.86 Open
Valve BF4	#N/A		4	#N/A	183.79	4.69	19 Open
Valve BF8	#N/A		8	#N/A	0	0	8.09 Open

Network Table - Nodes:

Node ID	Elevation	Base Demand GPM	Head ft	Pressure psi
Junc 2		0	0	230.59 99.92
Junc 3		0	0	230.59 99.92
Junc 4		0	0	230.59 99.91
Junc 5		0	0	230.59 99.91
Junc 6		0	0	230.59 99.91
Junc 7		0	0	230.59 99.91
Junc 8		0	0	230.59 99.91
Junc 9		0	0	230.59 99.91
Junc 10		0	0	230.59 99.91
Junc 11		0	0	230.59 99.91

Junc 12	0	0	238.67	103.42
Junc 13	0	0	238.67	103.42
Junc 14	0	0	230.59	99.91
Junc 15	0	0	230.08	99.69
Junc 16	0	0	211.08	91.46
Junc 17	0	183.79	209.81	90.91
Junc 18	0	0	230.59	99.91
Junc 19	0	0	218.15	94.52
Junc 20	0	0	191.29	82.88
Junc 21	0	41.28	176.66	76.55
Junc 23	0	0	230.59	99.92
Junc 25	0	0	230.59	99.92
Junc 26	0	0	230.59	99.91
Junc 27	0	0	230.59	99.91
Junc 30	0	0	230.59	99.91
Junc 22	0	0	230.59	99.92
Junc 24	0	0	230.59	99.92
Resvr 1	0	#N/A	0	0

MAX DAY + FIRE

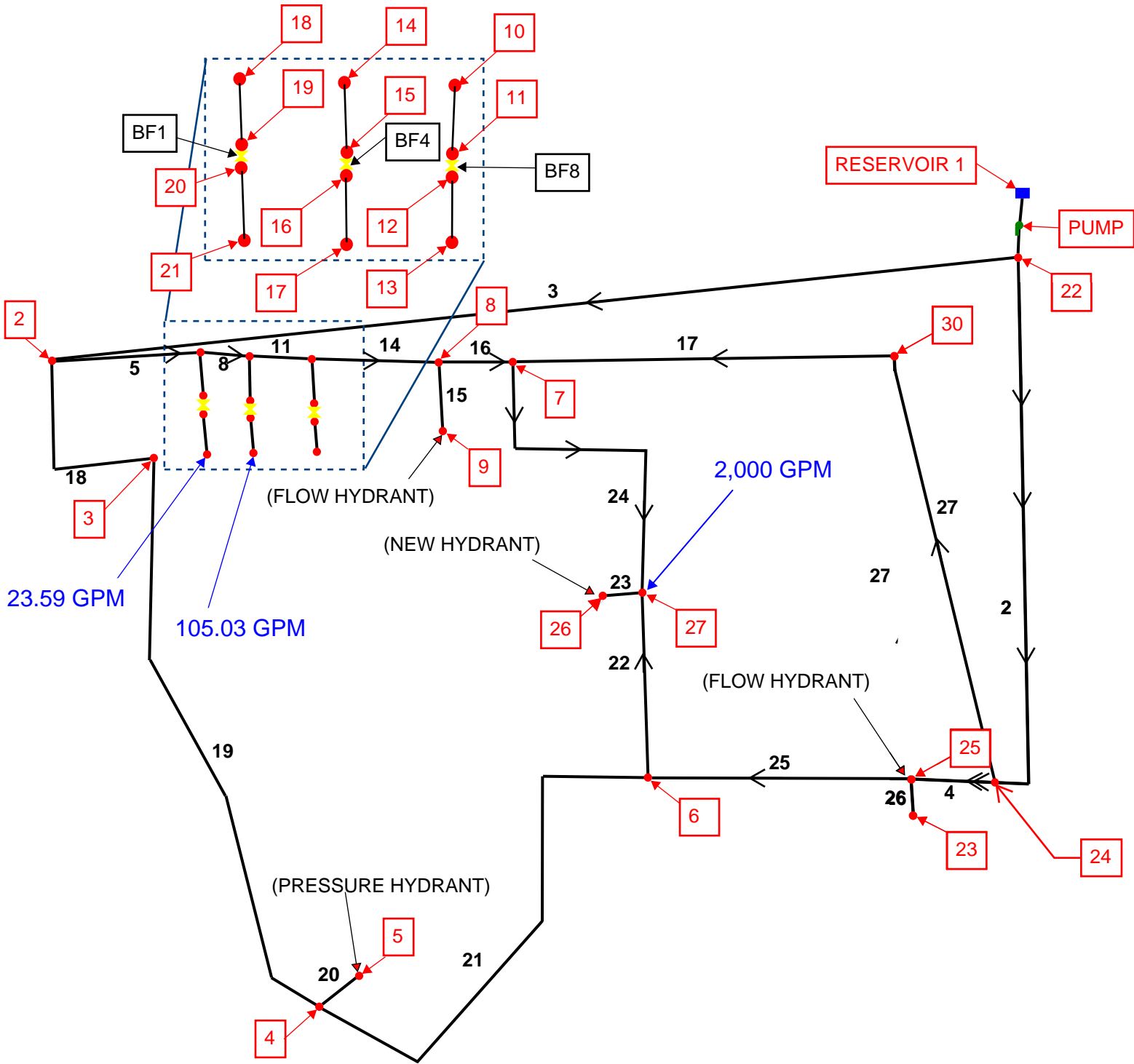

MODEL MAP GOLD DUST APARTMENTS

EPANET 2.2



 * E P A N E T *
 * Hydraulic and Water Quality *
 * Analysis for Pipe Networks *
 * Version 2.0 *

Input File: Gold Dust Apartments

Maximum Day + Fire Flow Demand Condition

Network Table - Links:

Link ID	Length ft	Diameter in	Roughness	Flow Rate gpm	Velocity ft/sec	Unit Headloss ft/Kft	Status
Pipe 18		64	8	140	0	0	0 Closed
Pipe 19		415	8	140	0	0	0 Closed
Pipe 20		10	6	140	0	0	0 Closed
Pipe 21		410	8	140	0	0	0 Closed
Pipe 16		60	12	140	-713.76	2.02	1.4 Open
Pipe 14		163	12	140	-713.76	2.02	1.26 Open
Pipe 11		13	12	140	-713.76	2.02	2.16 Open
Pipe 8		38	12	140	-818.79	2.32	1.97 Open
Pipe 5		16	12	140	-842.38	2.39	2.72 Open
Pipe 6		10	1	140	23.59	9.64	437.08 Open
Pipe 7		12	1	140	23.59	9.64	428.67 Open
Pipe 9		19	4	140	105.03	2.68	9.23 Open
Pipe 10		23	4	140	105.03	2.68	18.58 Open
Pipe 12		10	8	140	0	0	0 Open
Pipe 13		21	8	140	0	0	0 Open
Pipe 15		15	6	140	0	0	0 Open
Pipe 25	263.40		8	140	-816.6	5.21	11.9 Open
Pipe 26	22		6	140	0	0	0 Open
Pipe 24	202		8	140	1183.4	7.55	24.38 Open
Pipe 22	134		8	140	-816.6	5.21	11.57 Open
Pipe 23	12		6	140	0	0	0 Open
Pipe 17	396		12	140	-469.64	1.33	0.57 Open
Pipe 3	1	100	140	842.38	0.03	0	0 Open
Pipe 27	375.50		12	140	469.64	1.33	0.56 Open
Pipe 4	54		8	140	-816.6	5.21	12.5 Open
Pipe 2	1	100	140	-1286.24	0.05	0	0 Open
Pump Pump	#N/A	#N/A	#N/A	2128.62	0	-205.73	Open
Valve BF1	#N/A	1	#N/A	23.59	9.64	29.45	Open
Valve BF4	#N/A	4	#N/A	105.03	2.68	17.79	Open
Valve BF8	#N/A	8	#N/A	0	0	8.09	Open

Network Table - Nodes:

Node ID	Elevation	Base Demand GPM	Head ft	Pressure psi	
Junc 2		0	0	205.73	89.14
Junc 3		0	0	204.46	88.59
Junc 4		0	0	203.19	88.04
Junc 5		0	0	203.19	88.04
Junc 6		0	0	201.92	87.49
Junc 7		0	0	205.3	88.96
Junc 8		0	0	205.38	88.99
Junc 9		0	0	205.38	88.99
Junc 10		0	0	205.59	89.08
Junc 11		0	0	205.59	89.08

Junc 12	0	0	213.67	92.58
Junc 13	0	0	213.67	92.58
Junc 14	0	0	205.62	89.09
Junc 15	0	0	205.44	89.02
Junc 16	0	0	187.65	81.31
Junc 17	0	105.03	187.23	81.12
Junc 18	0	0	205.69	89.13
Junc 19	0	0	201.32	87.23
Junc 20	0	0	171.87	74.47
Junc 21	0	23.59	166.72	72.24
Junc 23	0	0	205.06	88.85
Junc 25	0	0	205.06	88.85
Junc 26	0	0	200.37	86.82
Junc 27	0	2000	200.37	86.82
Junc 30	0	0	205.52	89.05
Junc 22	0	0	205.73	89.14
Junc 24	0	0	205.73	89.14
Resvr 1	0 #N/A		0	0

INITIAL SERVICE

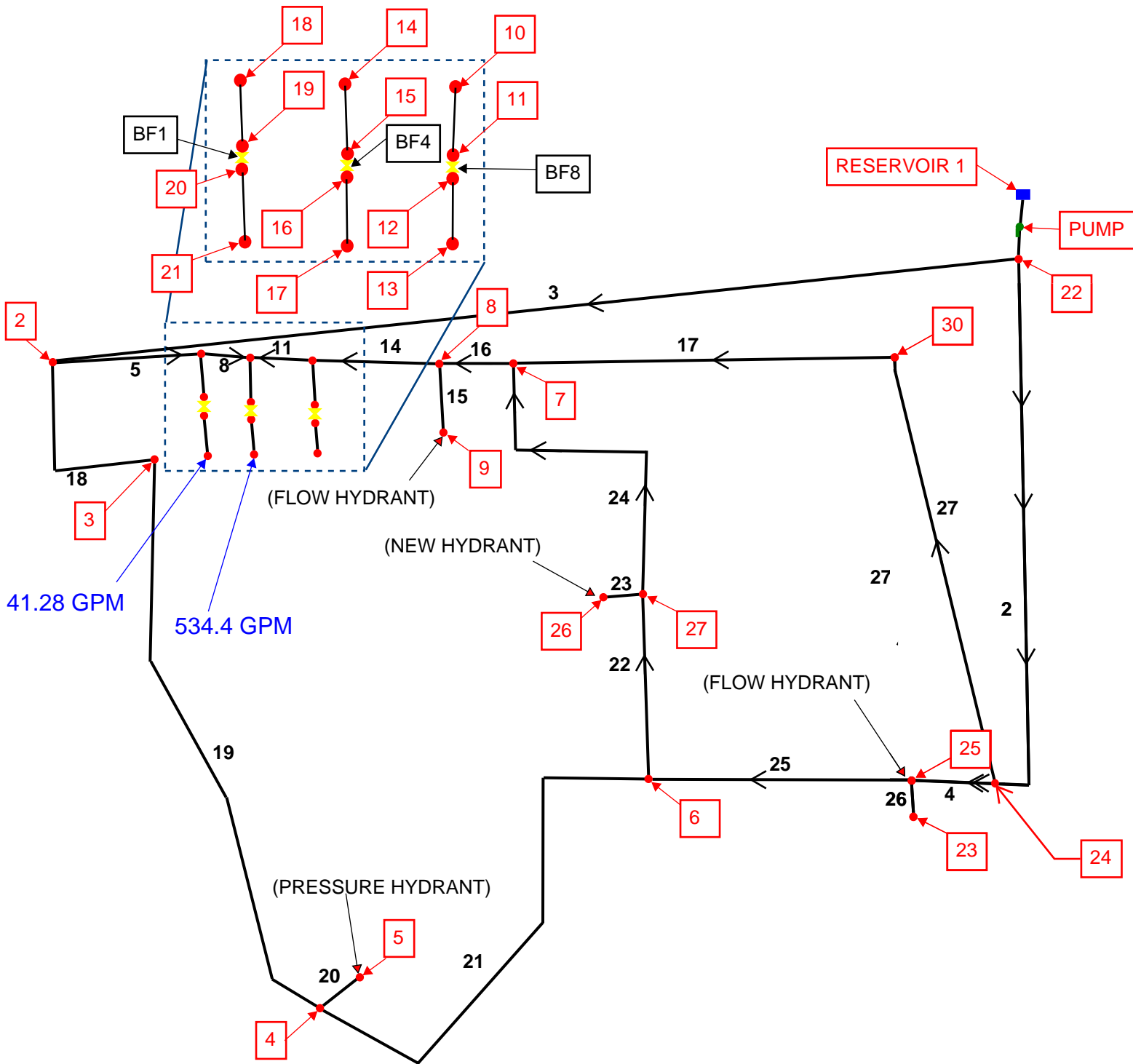

MODEL MAP GOLD DUST APARTMENTS

EPANET 2.2

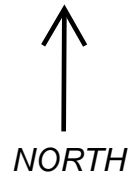

 * E P A N E T *
 * Hydraulic and Water Quality *
 * Analysis for Pipe Networks *
 * Version 2.0 *

Input File: Gold Dust Apartments

Initial Service Line Design Flow

Network Table - Links:

Link ID	Length ft	Diameter in	Roughness	Flow Rate gpm	Velocity ft/sec	Unit Headloss ft/Kft	Status
Pipe 18		64	8	140	0	0	0 Closed
Pipe 19		415	8	140	0	0	0 Open
Pipe 20		10	6	140	0	0	0 Closed
Pipe 21		410	8	140	0	0	0 Closed
Pipe 16		60	12	140	125.54	0.36	0.05 Open
Pipe 14		163	12	140	125.54	0.36	0.05 Open
Pipe 11		13	12	140	125.54	0.36	0.08 Open
Pipe 8		38	12	140	-408.76	1.16	0.53 Open
Pipe 5		16	12	140	-449.86	1.28	0.82 Open
Pipe 6		10	1	140	41.1	16.79	1234.18 Open
Pipe 7		12	1	140	41.1	16.79	1208.65 Open
Pipe 9		19	4	140	534.3	13.64	199.18 Open
Pipe 10		23	4	140	534.3	13.64	441.15 Open
Pipe 12		10	8	140	0	0	0 Open
Pipe 13		21	8	140	0	0	0 Open
Pipe 15		15	6	140	0	0	0 Open
Pipe 25		263.40	8	140	-33.95	0.22	0.03 Open
Pipe 26		22	6	140	0	0	0 Open
Pipe 24		202	8	140	-33.95	0.22	0.03 Open
Pipe 22		134	8	140	-33.95	0.22	0.03 Open
Pipe 23		12	6	140	0	0	0 Open
Pipe 17		396	12	140	-91.59	0.26	0.03 Open
Pipe 3		1	100	140	449.86	0.02	0 Open
Pipe 27		375.50	12	140	91.59	0.26	0.03 Open
Pipe 4		54	8	140	-33.95	0.22	0.03 Open
Pipe 2		1	100	140	-125.54	0.01	0 Open
Pump Pump		#N/A	#N/A	#N/A	575.4	0	-228.71 Open
Valve BF1		#N/A	1	#N/A	41.1	16.79	26.82 Open
Valve BF4		#N/A	4	#N/A	534.3	13.64	27.36 Open
Valve BF8		#N/A	8	#N/A	0	0	8.08 Open

Network Table - Nodes:

Node ID	Elevation	Base Demand GPM	Head ft	Pressure psi
Junc 2	0.00	0.00	228.71	99.10
Junc 3	0.00	0.00	228.11	98.84
Junc 4	0.00	0.00	228.11	98.84
Junc 5	0.00	0.00	228.11	98.84
Junc 6	0.00	0.00	228.70	99.10
Junc 7	0.00	0.00	228.69	99.09
Junc 8	0.00	0.00	228.69	99.09
Junc 9	0.00	0.00	228.69	99.09
Junc 10	0.00	0.00	228.68	99.09
Junc 11	0.00	0.00	228.68	99.09

Junc 12	0.00	0.00	220.59	95.58
Junc 13	0.00	0.00	220.59	95.58
Junc 14	0.00	0.00	228.68	99.09
Junc 15	0.00	0.00	224.89	97.45
Junc 16	0.00	0.00	197.54	85.59
Junc 17	30.00	534.30	187.39	68.20
Junc 18	0.00	0.00	228.70	99.09
Junc 19	0.00	0.00	216.36	93.75
Junc 20	0.00	0.00	189.54	82.13
Junc 21	0.00	41.10	175.03	75.84
Junc 23	0.00	0.00	228.71	99.10
Junc 25	0.00	0.00	228.71	99.10
Junc 26	0.00	0.00	228.70	99.09
Junc 27	0.00	0.00	228.70	99.09
Junc 30	0.00	0.00	228.70	99.10
Junc 22	0.00	0.00	228.71	99.10
Junc 24	0.00	0.00	228.71	99.10
Resvr 1	0.00	#N/A	0.00	0.00