



GOLD DUST APARTMENTS

Final Sewer Basis of Design Report

76-PA-2022 (4-ZN-2022
& 2-GP-2022)

Prepared For: ESG Architecture & Design

April 17, 2023



GOLD DUST APARTMENTS

Final Sewer Basis of Design Report

10050 N Scottsdale Road, Paradise Valley, AZ

76-PA-2022 (4-ZN-2022 & 2-GP-2022)

Prepared For: ESG Architecture & Design
Stephen M. Krager
High Street Residential
2575 East Camelback Road, Suite 400
Phoenix, AZ 85016
P: 602.222.4000

April 17, 2023

Shannon Mauck, PE
Senior Project Manager
1626 N Litchfield Road, Suite 150
Goodyear, AZ 85395
P: 623.935.2258

Dibble & Associates Consulting Engineers, Inc., dba Dibble



C Shannon Mauck

Table of Contents

1. INTRODUCTION.....	1
2. EXISTING CONDITIONS	2
3. DESIGN CRITERIA.....	2
4. DESIGN METHODOLOGY	3
4.1 SEWER DESIGN	3
4.2 SEWER CAPACITY	4
5. PROPOSED CONDCTIONS	4
6. RESULTS.....	4
7. CONCLUSIONS	4
8. REFERENCES	4

List of Figures

Figure 1 – VICINITY MAP	1
-------------------------------	---

List of Tables

Table 1- DEMAND ALLOCATION SUMMARY	3
--	---

List of Equations

Equation 1 – AVERAGE DAY FLOW	3
Equation 2 – PEAK DAY FLOW	3
Equation 3 – CONVERSION TO CFS.....	3

Appendices

Appendix A – ZONING MAPS.....	A
Appendix B –UTILITY EXHIBIT	B
Appendix C – SEWER DEMAND CALCULATIONS	C
Appendix D – HYDRAFLOW EXPRESS RESULTS	D
Appendix E – SKELETAL MAP	E
Appendix F – SEWER SUMMARY TABLES.....	F



1. INTRODUCTION

This report presents a final sewer plan for the City of Scottsdale as a part of the Gold Dust Apartments project. The purpose of this report is to provide analysis and results for the existing and proposed sewer distribution system at the site. The Gold Dust Apartments site has 215 units of residential use and 7,500 square feet of nonresidential use. The project site is approximately 4.2 acres. The existing site has a fully developed one-story commercial development that will be demolished. The Gold Dust Apartments project includes the design of a new mixed-use building, associated utilities, and hardscape improvements. This report provides the sewer analysis and results for the project.

The project is located at the intersection of Gold Dust Ave. and Scottsdale Road, in the northeast quadrant of Township 3 North, Range 4 East, Section 27. This site is bounded by two existing buildings to the east, residential apartments to the west, Acacia Dr to the south, and Gold Dust Ave to the north. This site has an Assessor's Parcel Number (APN) of 175-56-002H. See **Figure 1** for a location map.

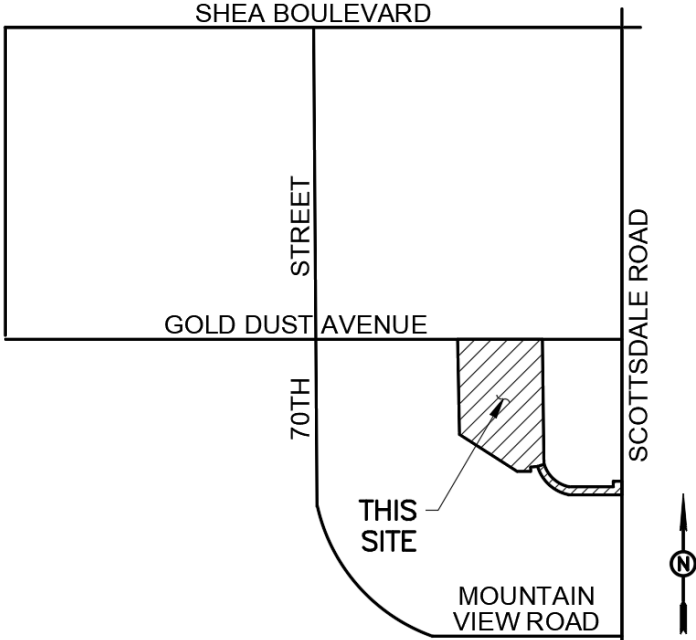

OVERALL DEVELOPMENT
NOT TO SCALE

Figure 1 - VICINITY MAP

2. EXISTING CONDITIONS

The Gold Dust Apartments is located on the southwest corner of the intersection of N Scottsdale Road and E Gold Dust Ave. This project lies on approximately 4.2 acres of fully developed land with an existing shopping center and parking lot. This project is currently zoned PUD per the City of Scottsdale zoning maps. See **Appendix A** for city zoning maps.

The site is located within the City of Scottsdale's service area for wastewater. There is an 8-inch public sewer main that runs through the east side existing parking lot. This 8-inch public sewer main is connected to the 24-inch public gravity sewer main that runs through Scottsdale Road. See **Appendix B** for the sewer exhibit for locations of all existing sewer lines.

3. DESIGN CRITERIA

The sewer lines serving the site will be designed to meet Maricopa Association of Governments (MAG) and the Arizona Administration Code (AAC) standards and details. Additionally, the following criteria per the City of Scottsdale (*DS&PM*) will be met:

- No public sewer lines will be less than 8" in diameter.
- The Manning's "n" value of all pipes shall be 0.013.
- Sanitary sewer lines are to be VCP, PVC, or DIP.
- Sewer lines shall be designed and constructed to give mean full flow velocities equal to or greater than 2.5 feet per second.
- The maximum velocity shall be 10 feet per second at peak flow.
- Pipes shall have a maximum d/D ratio of 0.65 for gravity sewer lines 12" in diameter and less in the ultimate peak flow condition. For gravity sewer lines greater than 12" in diameter shall not exceed a d/D ratio of 0.70.
- Sewer manholes shall be located at a maximum spacing of 500 feet for sewer pipes between 8" to 15" and 600 feet for sewer pipes between 18"-30" in diameter.
- Manholes shall be 4-feet in diameter for manholes less than 10-feet deep or connecting to lines less than 15" in diameter. For manholes more than 10-feet deep or the line is greater than 15", the manhole shall be 5-feet in diameter.
- The maximum sewer cleanout spacing shall be 150 feet for 6" pipes or smaller.
- Sewer service pipes shall have a minimum diameter of 6 inches for commercial developments.
- No sanitary sewer lines shall be installed with less than 4 feet of cover over the top of the pipe.
- All sewers must maintain a 1-foot vertical clearance to dry utilities. Sewer mains below water mains shall maintain 1 to 2 feet of vertical separation with extra protection, greater than 2 feet of separation with no protection. Sewer mains above water mains shall maintain a minimum of 2 feet of vertical separation and always require protection. Sewer service below water mains shall maintain 1-foot of vertical separation. Sewer services above water mains shall maintain a minimum of 1-foot of vertical separation and always require protection.
- All sewers must maintain 6 feet of horizontal clearance to dry utilities. Water mains and sewer mains shall run parallel to each other with 9 feet of separation to pipe centerlines to maintain 6 feet of clearance at manholes.

4. DESIGN METHODOLOGY

4.1 SEWER DESIGN

The City of Scottsdale (*DS&PM*) specified the design demand for a high-density condominium uses classifications as 140 gallons per day (GPD) per unit. The high-density condominium demand was used as an apartment demand is not provided. The maximum design peaking factor for a high-density condominium is 4.5 per the DS&PM. The proposed building also provides 5,000 square feet of office space. The demand in gpd for an office space is 0.4 per square foot. The peaking factor for the office land use is 3.0. The mixed-use building is also providing 2,500 square feet of a fitness/yoga center. The demand in gpd for a fitness center/spa/health club is 0.8 per square foot. The peaking factor for the fitness/yoga land use is 3.5. The mixed-use building is also providing a pool that will have a backwash rate of 50 gallons per minute for 5 minutes each week. See **Appendix C** for sewer demand calculations.

The Average Day Flow for the facility was calculated with **Equation 1 below**.

Equation 1 – AVERAGE DAY FLOW

$$Q_{Avg} = \frac{\# \text{ units}}{1} * \frac{\# \text{ gal}}{\text{unit}} * \frac{1 \text{ day}}{24 \text{ hrs}} * \frac{1 \text{ hr}}{60 \text{ min}}$$

The Peak Day Flow was calculated with **Equation 2 below**.

Equation 2 – PEAK DAY FLOW

$$Q_{peak} = Q_{Avg} * (PHF) = Q_{Avg} * 4.5$$

Equation 3 – CONVERSION TO CFS

$$Q_{peak}(CFS) = 353.09 * \left(\frac{1 \text{ ft}^3}{7.48 \text{ gal}} \right) * \left(\frac{1 \text{ min}}{60 \text{ sec}} \right) = 0.79 \text{ CFS}$$

Refer to **Table 1** for sewer demand calculations.

Table 1- DEMAND ALLOCATION SUMMARY

Facility	Number of Units	GPD	Average Day Demand		Peak Day Demand	
			GPD	GPM	GPD	GPM
Apartments	215	140	30,100	20.90	135,450	94.06
Office	5,000	0.4	2,000	1.39	6,000	4.17
Yoga	2,500	0.8	2,000	1.39	7,000	4.86
Pool				250		250

4.2 SEWER CAPACITY

Peak flows were calculated using the demand calculations in **Appendix C**. See **Appendix D** for HydraFlow Express models showing the maximum peak day flow capacity models.

Based on design criteria from MEP the peak flows at the different building connection sewer service lines are split at a particular percentage of the overall peak day flow. To provide the peak flow rates at the different lines along the sewer system a skeletal map and junctions table was made to show the flows through the different pipes throughout the system. For a detailed map and calculations on the skeletal map see **Appendix E & F**

5. PROPOSED CONDITIONS

As part of the proposed site improvements, there will be an 8-inch private sewer service line tied into the existing manhole onsite between the CVS and California Kitchen. The Gold Dust Apartments will be served by four new sewer service building connections. There will be 2 new 8-inch sewer service building connections and 2 new 6-inch sewer service building connections. All new private sewer service lines will be polyvinyl chloride (PVC) SDR35. To ensure that the proposed sewer improvements meet the City of Scottsdale requirements, three new manholes are proposed on site for all points of connections that changes pipe size. Sewer cleanouts are used within every 150 feet along the new 6-inch sewer service connections. See **Appendix E** for reference on location of the connection of the existing and new sewer main extension as well as the locations of all proposed sewer service connections.

6. RESULTS

To ensure that the proposed sewer line is designed and constructed to give mean full flow velocities equal to or greater than 2.5 feet per second and less than 10 feet per second, HydraFlow Express was used to determine the results of the proposed 8-inch sewer service line. The d/D ratio could not surpass .65 when using a pipe less than 12 inches in diameter. The diameters of the pipes used to show that the d/D ratio is not surpassed, was the 6-inch sewer service line and 8-inch sewer service line that will serve as the sewer connections to the building. Refer to **Appendix D** for HydraFlow Express results. Refer to **Appendix E** for the skeletal sewer collection system map and **Appendix F** for pipe and junction summaries.

7. CONCLUSIONS

The proposed sewer system supports the development of the Gold Dust Apartments while adhering to City of Scottsdale design standards. One 8-inch private sewer service line will serve the Gold Dust Apartments.

8. REFERENCES

City of Scottsdale. Design Standards and Policies Manual, 2018.

Maricopa Association of Governments. Uniform Standard Details for Public Works Construction, 2021.

Arizona Administrative Code (AAC) Title 18, September 2016.

Arizona Department of Environmental Quality (ADEQ) Bulletins 11, July 1978.

Appendix A – ZONING MAPS

1,922 records

-
-
-
-

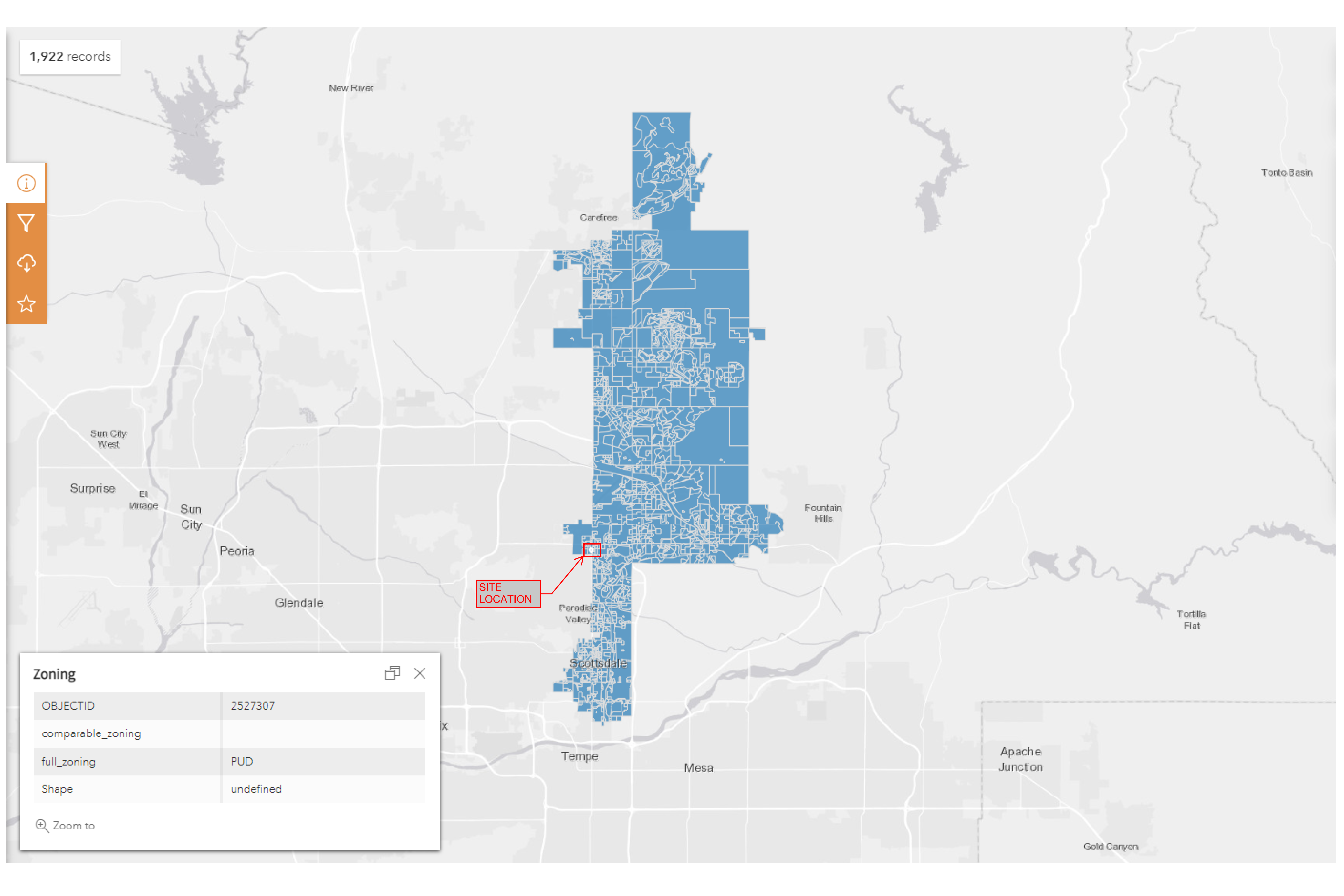

Zoning

OBJECTID	2527307
comparable_zoning	
full_zoning	PUD
Shape	undefined

Zoom to

1,922 records

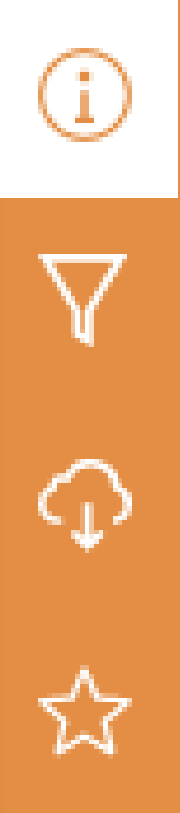

SITE LOCATION

Zoning [Close] [Copy]

OBJECTID	2527307
comparable_zoning	
full_zoning	PUD
Shape	undefined

🔍 Zoom to



Appendix B –UTILITY EXHIBIT



500 Washington Avenue South, Suite 1080
Minneapolis, MN 55415
p 612.339.5508 | f 612.339.5382
www.esgarch.com

- CONSTRUCTION NOTES**
- 71 WATER LINE W/FITTINGS, DIP CL 350 W/POLYWRAP, SIZE PER PLAN
 - 72 WATER SERVICE LINE W/FITTINGS, PVC SCH 40 SIZE PER PLAN
 - 74 WATER METER VAULT COS STD DET 2345-1
 - 76 12"X8" TAPPING SLEEVE & VALVE W/BOX & COVER, MAG STD DET 340
 - 77 WATER SERVICE CONNECTION SIZE PER PLAN, COS STD DET 2330
 - 79 8" DOUBLE CHECK BACKFLOW PREVENTER COS STD DET 2351
 - 80 1" REDUCED PRESSURE BACKFLOW PREVENTER COS STD DET 2354
 - 82 FIRE HYDRANT ASSEMBLY MAG STD DET 360
 - 84 FIRE LINE W/FITTINGS, PVC C-900, DR18 SIZE PER PLAN
 - 85 4" REDUCED PRESSURE BACKFLOW PREVENTER COS STD DET 2353
 - 90 SEWER SERVICE LINE, PVC SDR 35 SIZE PER PLAN
 - 92 SEWER MANHOLE COS STD DET 2420
 - 93 SEWER CLEANOUT W/BOX & COVER MAG STD DET 441

- REFERENCE NOTES**
- 3 DRAINAGE IMPROVEMENTS REFER TO GRADING & DRAINAGE PLANS
 - 7 FOR CONTINUATION REFER TO PLUMBING PLANS
 - 8 FOR CONTINUATION REFER TO FIRE PROTECTION PLANS
 - 13 FOR CONTINUATION REFER TO LANDSCAPE PLANS

NOTES:

- EXISTING UTILITIES ARE SHOWN WITH BEST AVAILABLE INFORMATION. NOT ALL UTILITIES MAY BE SHOWN. CONTRACTOR SHALL VERIFY THE HORIZONTAL AND VERTICAL LOCATION OF ALL EXISTING UTILITIES PRIOR TO CONSTRUCTION.

DRB RE-SUBMITTAL 04/17/2023

ORIGINAL ISSUE:

REVISIONS

No.	Description	Date

221564
PROJECT NUMBER
KR SM
DRAWN BY CHECKED BY

KEY PLAN

Gold Dust Ave & Scottsdale Rd

UTILITY PLAN

C5.1

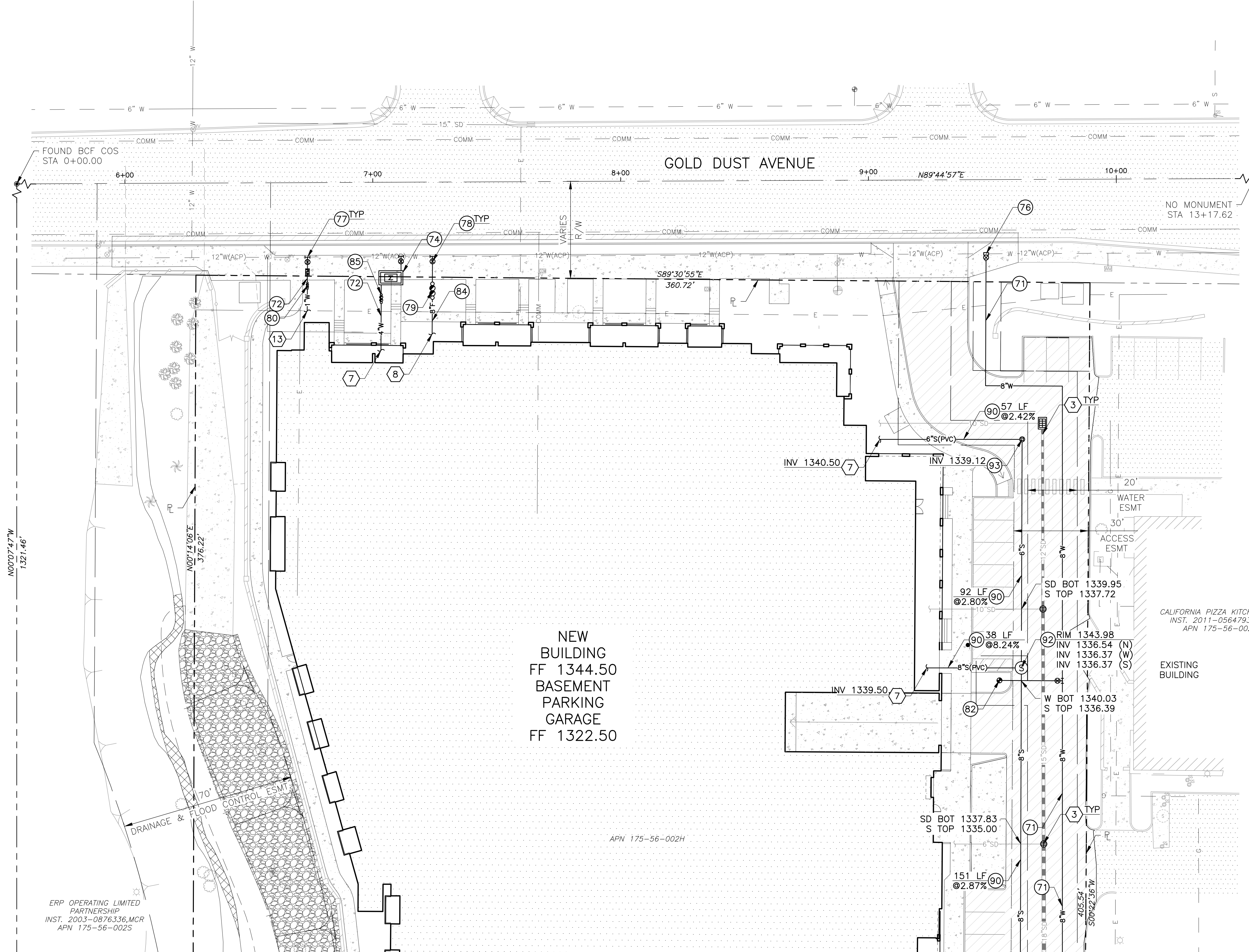

MATCH LINE SEE SHEET C5.2

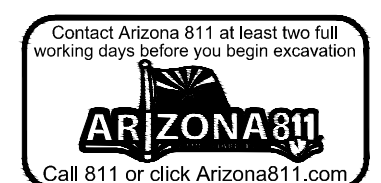
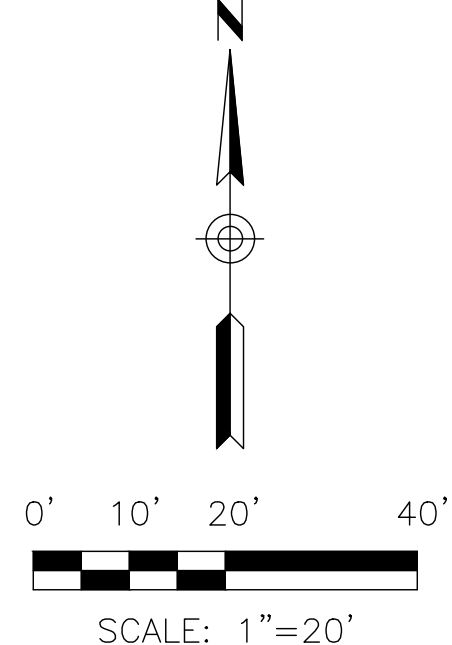

G:\2023\1122028_Gold_Dust_Apartments\CAD\Exhibit\sewer exhibit.dwg 17/04/2023

ERP OPERATING LIMITED PARTNERSHIP
INST. 2003-0876336, MCR
APN 175-56-002S

FOUND BCHH COS

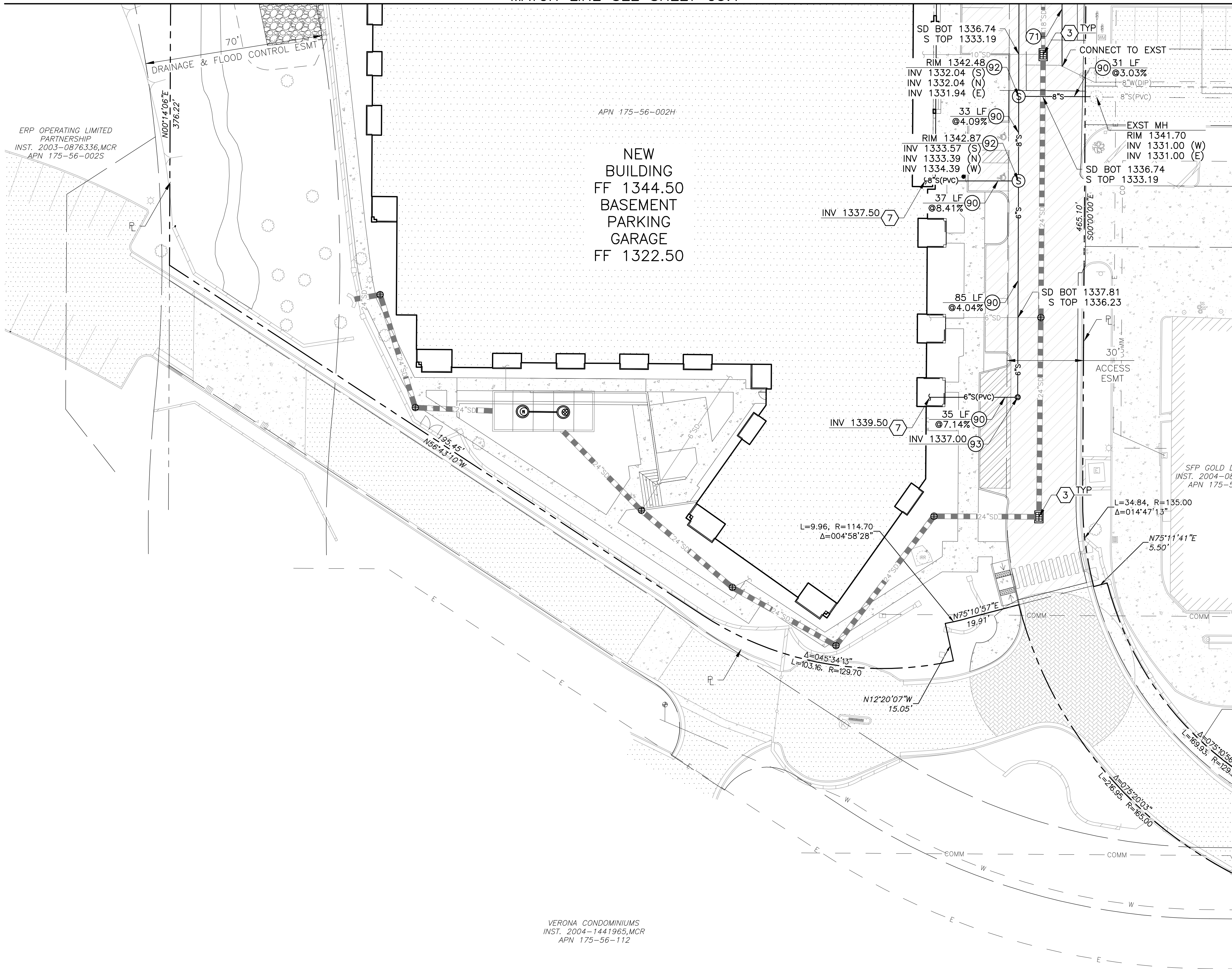

- CONSTRUCTION NOTES**
- ⑦ WATER LINE W/FITTINGS, DIP CL 350 W/POLYWRAP, SIZE PER PLAN
 - ⑨ SEWER SERVICE LINE, PVC SDR 35 SIZE PER PLAN
 - ⑨② SEWER MANHOLE COS STD DET 2420
 - ⑨③ SEWER CLEANOUT W/BOX & COVER MAG STD DET 441

- REFERENCE NOTES**
- ③ DRAINAGE IMPROVEMENTS REFER TO GRADING & DRAINAGE PLANS
 - ⑦ FOR CONTINUATION REFER TO PLUMBING PLANS

NOTES:

- EXISTING UTILITIES ARE SHOWN WITH BEST AVAILABLE INFORMATION. NOT ALL UTILITIES MAY BE SHOWN. CONTRACTOR SHALL VERIFY THE HORIZONTAL AND VERTICAL LOCATION OF ALL EXISTING UTILITIES PRIOR TO CONSTRUCTION.

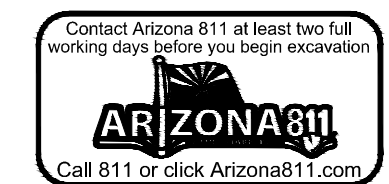
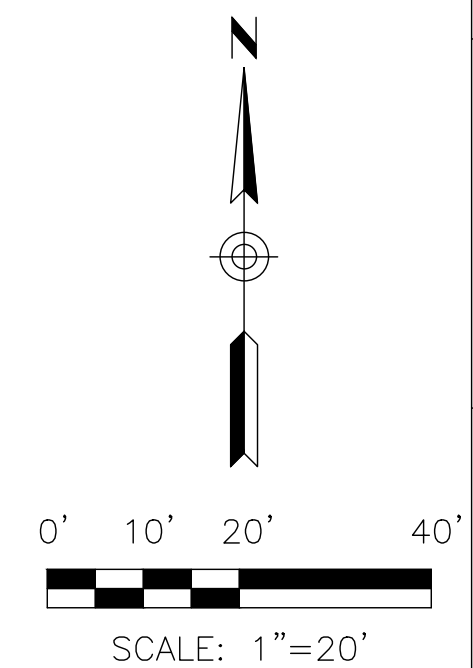

Gold Dust Ave & Scottsdale Rd
Scottsdale, AZ



500 Washington Avenue South, Suite 1080
Minneapolis, MN 55415
p 612.339.5508 | f 612.339.5382
www.esgarch.com

DRB
RE-SUBMITTAL
04/17/2023

ORIGINAL ISSUE:
REVISIONS
No. Description Date

221564
PROJECT NUMBER
KR SM
DRAWN BY CHECKED BY

KEY PLAN

Gold Dust Ave & Scottsdale Rd

UTILITY PLAN
C5.2

NEW BUILDING
FF 1344.50
BASEMENT
PARKING
GARAGE
FF 1322.50

Appendix C – SEWER DEMAND CALCULATIONS



GOLD DUST APARTMENTS
DIBBLE PROJECT NO. 1122028
SEWER DEMAND CALCULATIONS

DES: KJR

DATE: 2023-0202

DEVELOPMENT SEWER DEMAND IN GALLONS PER MINUTE

LAND USE	NUMBER OF UNITS	NUMBER OF SF	DEMAND [GPM/UNIT]	AVERAGE DEMAND [GPM]	PEAK HOUR DEMAND [GPM]
APARTMENTS	215		140.0	20.90	94.06
OFFICE		5,000	0.4	1.39	4.17
YOGA		2,500	0.8	1.39	4.86
POOL	N/A	N/A	N/A	250.00	250.00
TOTAL INDOOR FLOW				273.68	353.09

Appendix D – HYDRAFLOW EXPRESS RESULTS

Channel Report

8-Inch Full Peak Flow Capacity

Circular

Diameter (ft) = 0.67

Invert Elev (ft) = 1.00

Slope (%) = 3.03

N-Value = 0.013

Calculations

Compute by: Known Q

Known Q (cfs) = 0.79

Highlighted

Depth (ft) = 0.29

Q (cfs) = 0.790

Area (sqft) = 0.15

Velocity (ft/s) = 5.37

Wetted Perim (ft) = 0.96

Crit Depth, Y_c (ft) = 0.42

Top Width (ft) = 0.66

EGL (ft) = 0.74

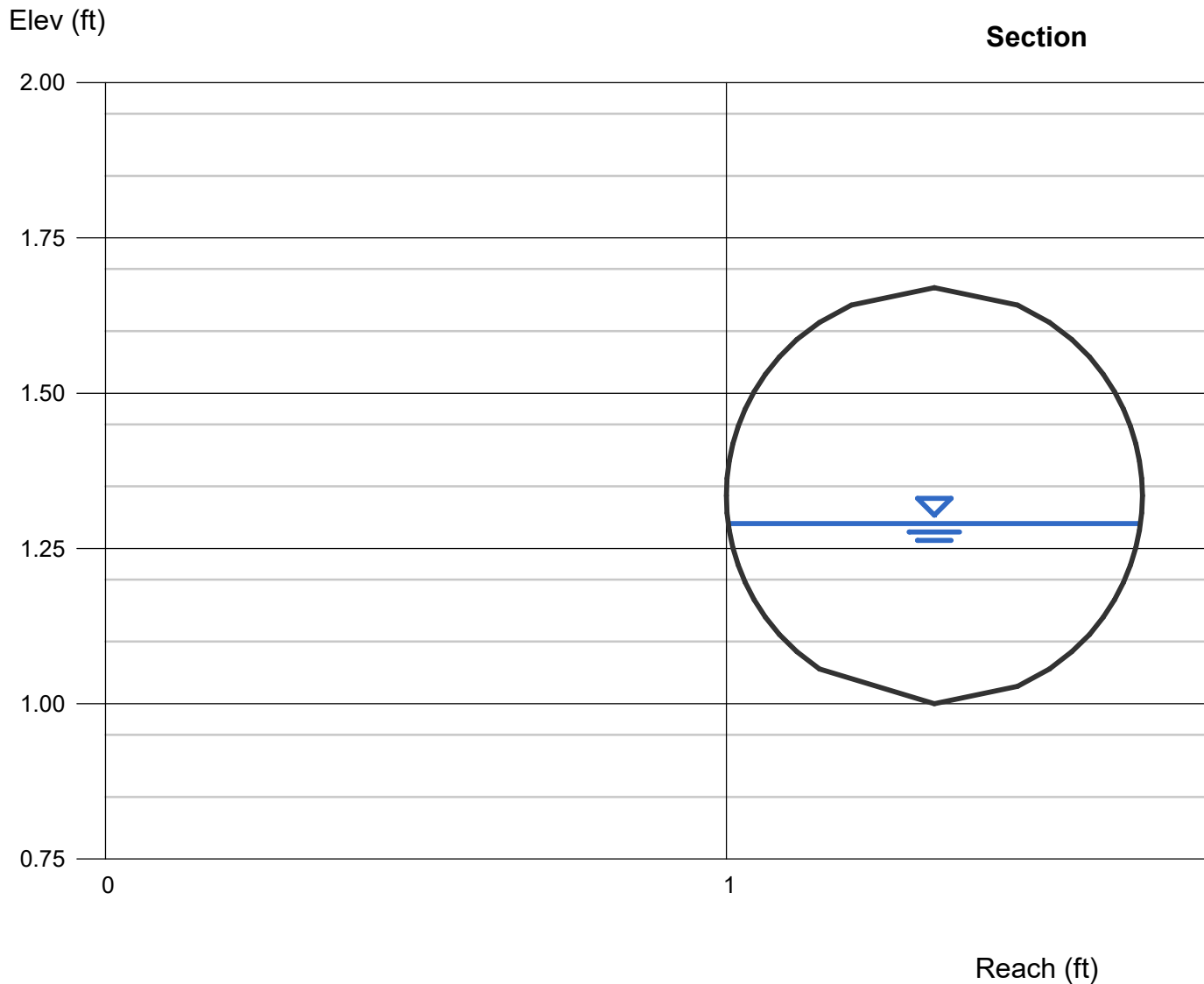

Appendix E – SKELETAL MAP



500 Washington Avenue South, Suite 1080
Minneapolis, MN 55415
p 612.339.5508 | f 612.339.5382
www.esgarch.com

I hereby certify that this plan, specification, or report was prepared by me or under my direct supervision and that I am a duly licensed architect under the laws of the State of Arizona

Signature _____
Typed or Printed Name _____
License # _____ Date _____

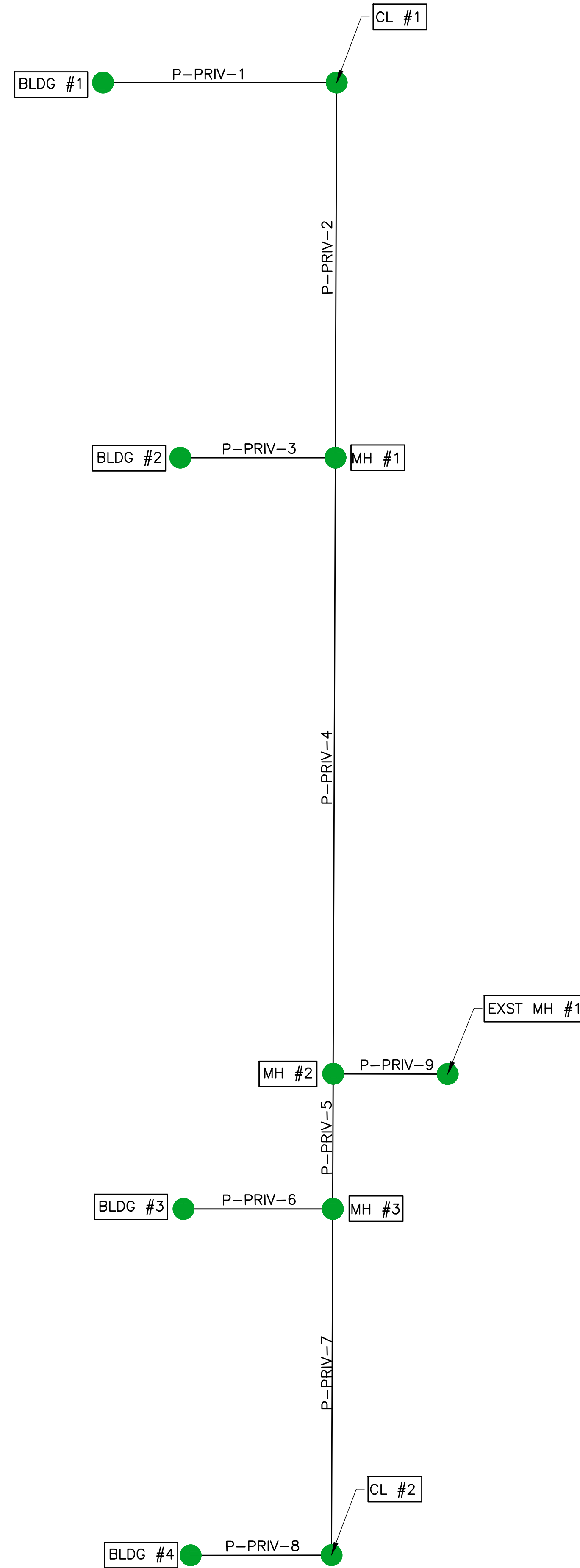

ABBREVIATIONS USED
MH - MANHOLE
EXST MH - EXISTING MANHOLE
CL - CLEANOUT
P-PRIV - PRIVATE SEWER LINE

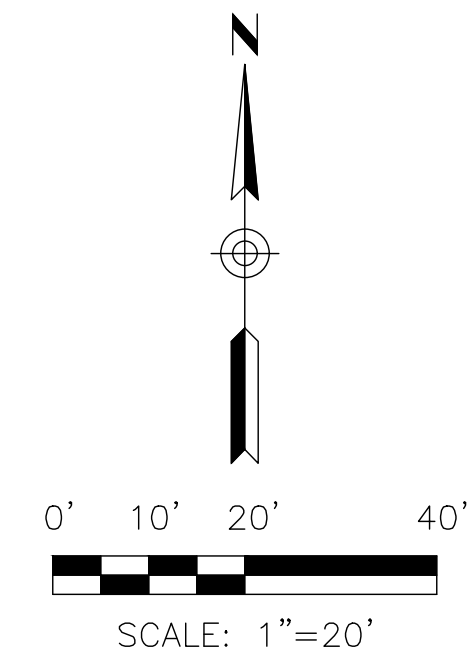

**DRB
SUBMITTAL
2/02/2023**

ORIGINAL ISSUE:
REVISIONS

No.	Description	Date

221564
PROJECT NUMBER
DRAWN BY _____ CHECKED BY _____

KEY PLAN
**SEWER DESIGN
SKELETAL MAP**

Gold Dust Ave &
Scottsdale Rd

Appendix F – SEWER SUMMARY TABLES

Pipe Summary

SN	Element ID	From (Inlet) Node	To (Outlet) Node	Length (ft)	Inlet Invert Elevation (ft)	Outlet Invert Elevation (ft)	Inlet Rim Elevation (ft)	Outlet Rim Elevation (ft)	Inlet Pipe Cover (ft)	Outlet Pipe Cover (ft)	Average Slope (%)	Diameter or Height (in)	Pipe Material	Manning's Roughness	Average Pipe Cover (ft)
1	P-PRIV-1	BLDG #1	CL #1	57	1340.50	1339.12	1344.50	1343.12	4.00	4.00	2.42	6.00	PVC SDR 35	0.0130	4.00
2	P-PRIV-2	CL #1	MH #1	92	1339.12	1336.36	1343.12	1343.98	4.00	7.62	3.00	6.00	PVC SDR 35	0.0130	5.72
3	P-PRIV-3	BLDG #2	MH #1	38	1339.50	1336.37	1344.50	1343.98	5.00	7.61	8.24	8.00	PVC SDR 35	0.0130	6.22
4	P-PRIV-4	MH #1	MH #2	151	1336.37	1332.04	1343.98	1342.48	7.61	10.44	2.87	8.00	PVC SDR 35	0.0130	8.94
5	P-PRIV-5	MH #3	MH #2	33	1333.39	1332.04	1342.87	1342.48	9.48	10.44	4.09	8.00	PVC SDR 35	0.0130	9.87
6	P-PRIV-6	BLDG #3	MH #3	37	1337.50	1334.39	1344.50	1342.87	7.00	8.48	8.41	8.00	PVC SDR 35	0.0130	8.15
7	P-PRIV-7	CL #2	MH #3	85	1337.00	1333.57	1341.05	1343.98	4.05	10.41	4.04	6.00	PVC SDR 35	0.0130	6.68
8	P-PRIV-8	BLDG #4	CL #2	35	1339.50	1337.00	1344.50	1341.05	5.00	4.05	7.14	6.00	PVC SDR 35	0.0130	4.53
9	P-PRIV-9	MH #2	EXST MH #1	31	1331.94	1331.00	1342.48	1341.75	10.54	10.75	3.03	8.00	PVC SDR 35	0.0130	10.60

Pipe Analysis Summary

SN	Element ID	*Peak Flow (gpm)	Peak Flow (cfs)	Full Flow Capacity (cfs)	Full Flow Capacity (gpm)	Peak Flow/ Full Flow Ratio [Q/Qfull]	Peak Flow Velocity (ft/sec)	Peak Flow Depth (ft)	Depth/ Diameter Ratio [d/D]
1	P-PRIV-1	24	0.05	0.8754	393	0.0608	4.05	0.26	0.52
2	P-PRIV-2	24	0.05	0.9745	437	0.0546	4.05	0.26	0.52
3	P-PRIV-3	35	0.08	3.4775	1561	0.0227	4.05	0.26	0.39
4	P-PRIV-4	59	0.13	2.0518	921	0.0644	3.13	0.27	0.41
5	P-PRIV-5	293	0.65	2.4507	1100	0.2667	3.13	0.27	0.41
6	P-PRIV-6	283	0.63	3.5129	1577	0.1797	4.05	0.26	0.39
7	P-PRIV-7	10	0.02	1.1302	507	0.0199	4.73	0.23	0.46
8	P-PRIV-8	10	0.02	1.5037	675	0.0149	4.05	0.26	0.52
9	P-PRIV-9	353	0.79	2.1099	947	0.3724	4.73	0.23	0.35

* Peaking Factor 4.5

Junction Summary

SN	Element ID	Invert Elevation (ft)	Ground/Rim (Max) Elevation (ft)	Pipe Cover (ft)
1	BLDG #1	1340.50	1344.50	4.00
2	BLDG #2	1339.50	1344.50	5.00
3	BLDG #3	1337.50	1344.50	7.00
4	BLDG #4	1339.50	1344.50	5.00
4	CL #1	1339.12	1343.12	4.00
5	CL #2	1337.00	1341.05	4.05
6	MH #1	1336.36 1336.37 1336.37	1343.98	7.62
7	MH #2	1332.04 1332.04 1331.94	1342.48	10.44
8	MH #3	1333.57 1334.39 1333.39	1342.87	9.30
9	EXST MH #1	1331.00	1341.75	10.75