



Development Review (Minor) Staff Approval

278-SA-2023

8101 McDowell Exterior
Repaint

APPLICATION INFORMATION

LOCATION:	8101 E McDowell Rd	APPLICANT:	Tim Dulany
PARCEL:	131-09-002P	COMPANY:	Tim Dulany
Q.S.:	12-47	ADDRESS:	2525 East Camelback Road, Suit Phoenix, AZ 85016
ZONING:	C-3 (C)	PHONE:	(602) 330-4468

Request: Request by applicant for approval of exterior paint modification to an existing commercial office building with Highway Commercial (C-3) zoning, located at 1575 N Hayden Road.

STIPULATIONS

1. Architectural elements, including dimensions, materials, form, color, and texture, shall be constructed to be consistent with the building elevations submitted by Tim Dulany, with a city staff approval date of 1/30/2024.

CONSTRUCTION DOCUMENT PLAN REVIEW SUBMITTAL REQUIREMENTS

No additional reviews or permits are required associated to this scope of work.

Expiration of Development Review (Minor) Approval

This approval expires two (2) years from date of approval if a permit has not been issued, or if no permit is required, work for which approval has been granted has not been completed.

Staff Signature:  Date: January 30, 2024

 Sandra Childers, 480-312-4214

Scottsdale Commerce Center

8101 East McDowell Road, Scottsdale, AZ

Paint Package

December 22, 2023

Key Notes

- 1 Paint Color - Grizzle Gray: SW 7068
- 2 Paint Color - Agreeable Gray: SW 7029

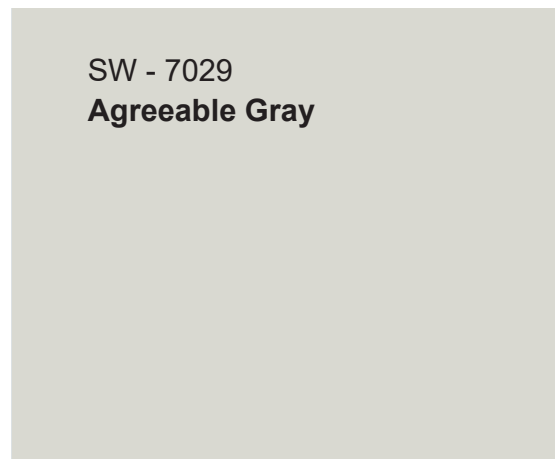
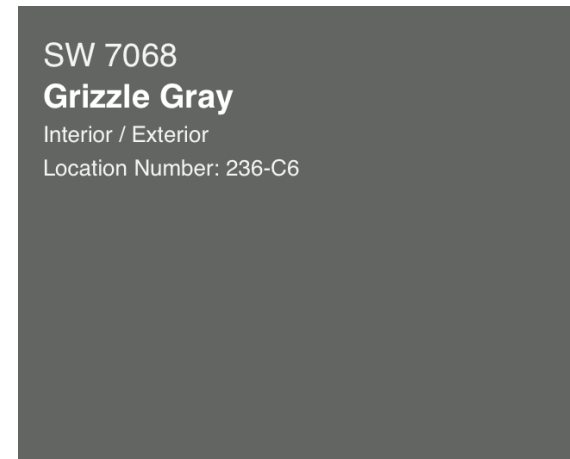

**STIPULATION SET
RETAIN FOR RECORDS
APPROVED**

01/30/2024
DATE

APPROVED BY

SW 7068
Grizzle Gray

SW 7029
Agreeable
Gray

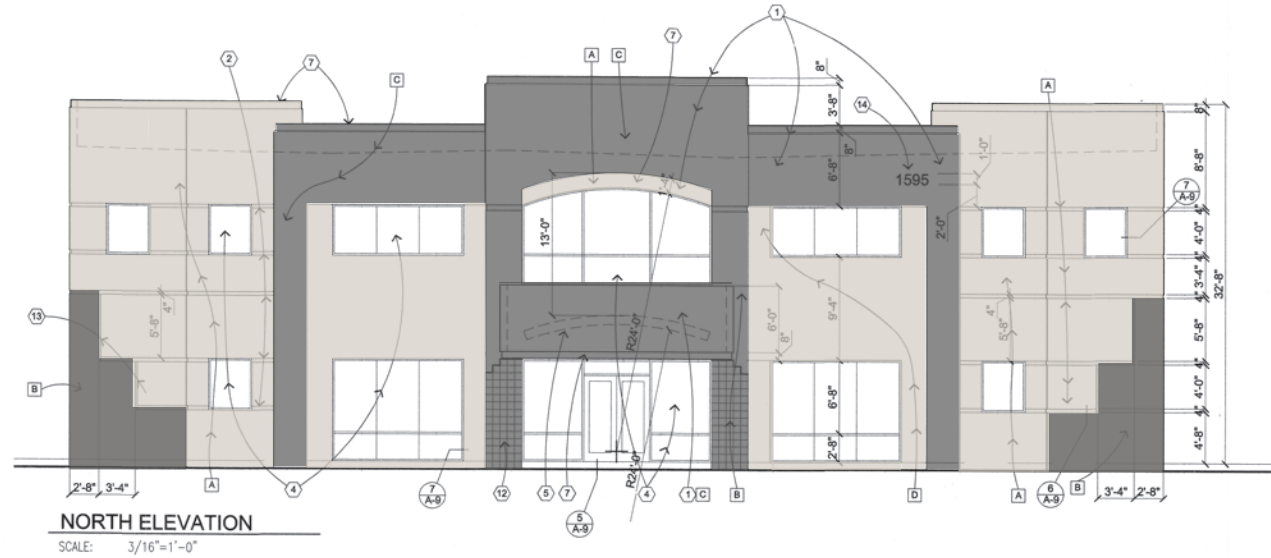

EXTERIOR ELEVATION KEYNOTES

- ① Concrete fill-up wall panel.
- ② 4"x1/2" deep reveal.
- ③ 8"x1/2" deep reveal.
- ④ Heat reflective glass in bronze anodized aluminum frames.
- ⑤ Steel canopy beyond parapet at entry element.
- ⑥
- ⑦ 1/2" deep reveal.
- ⑧ Hollow metal door and frame.
- ⑨ Overhead sectional steel door.
- ⑩ Line of roof beyond parapet.
- ⑪ Mechanical unit beyond parapet.
- ⑫ 8" center scored CMU.
- ⑬ 1"x1/2" deep reveal.
- ⑭ 12" high individually mounted reverse pan channel anodized dark bronze helvetica numbers.
- ⑮ Roof drain.

EXTERIOR PAINT COLORS
(Frazee Paints)

- A) Crisp Khaki, 8233M
- B) Jericho Brown, 8305D
- C) Ayers Rock, 7826A
- D) Desert Edge, 7824M

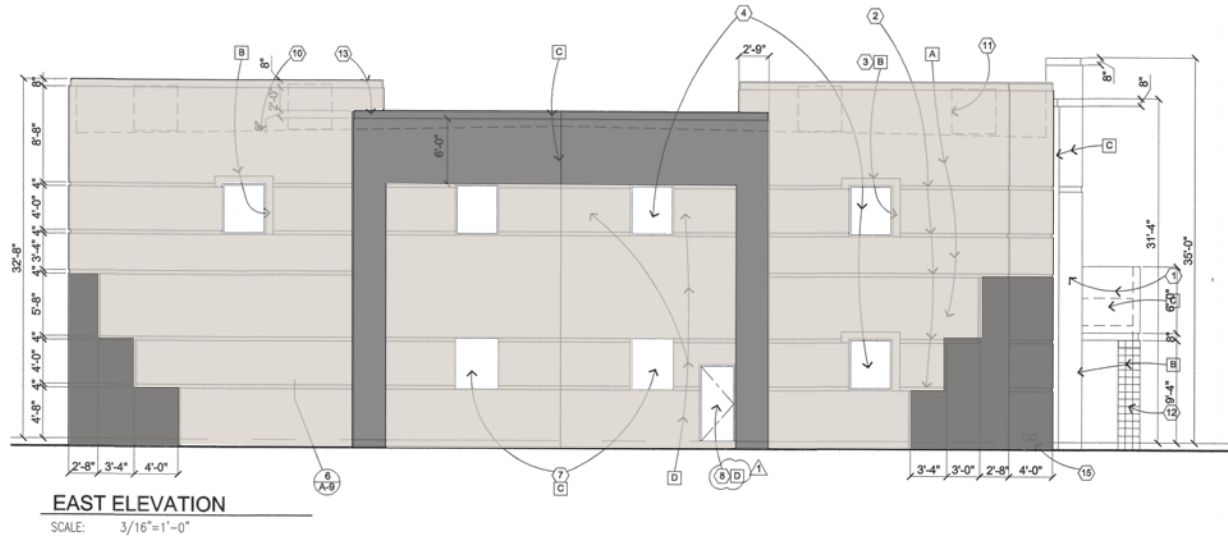

CITY BUILDING ELEVATION NOTES

- 1. All roof top mechanical equipment shall be completely screened by parapet walls or within roof structure.
- ② All ground mounted mechanical equipment shall be completely screened by screen walls to +1' above unit height with color and texture to match the building.
- ③ Roof mounted communication equipment, including satellite dishes, shall be completely screened by the parapet walls or free standing screen walls.
- ④ Ground mounted communication equipment, including satellite dishes, shall be completely screened by freestanding screen walls to +1' above unit height subject to Development Quality/Compliance approval.
- 5. No exterior ladders that can be visible from offsite are allowed.

STAFF APPROVAL # _____ SA _____ COS PLAN #3578-02-2
NATIVE PLANT # 106 NP 2002 39-DR-2002



W. Winton architects, inc.
4222 N. 12th Street, Suite 102, Phoenix, Arizona 85014
(602) 230-9778 FAX (602) 265-9739



**NEW BUILDING FOR
REPUBLIC WEST
SCOTTSDALE, ARIZONA
SUN STATE BUILDERS**

Job no. 02128
drawn WDH
approved RBW
date 10/18/02

revisions
① CITY 11/6/02

A-3

**STIPULATION SET
RETAIN FOR RECORDS
APPROVED**

01/30/2024
DATE

APPROVED BY

SW 7068
Grizzle Gray

SW 7029
Agreeable
Gray

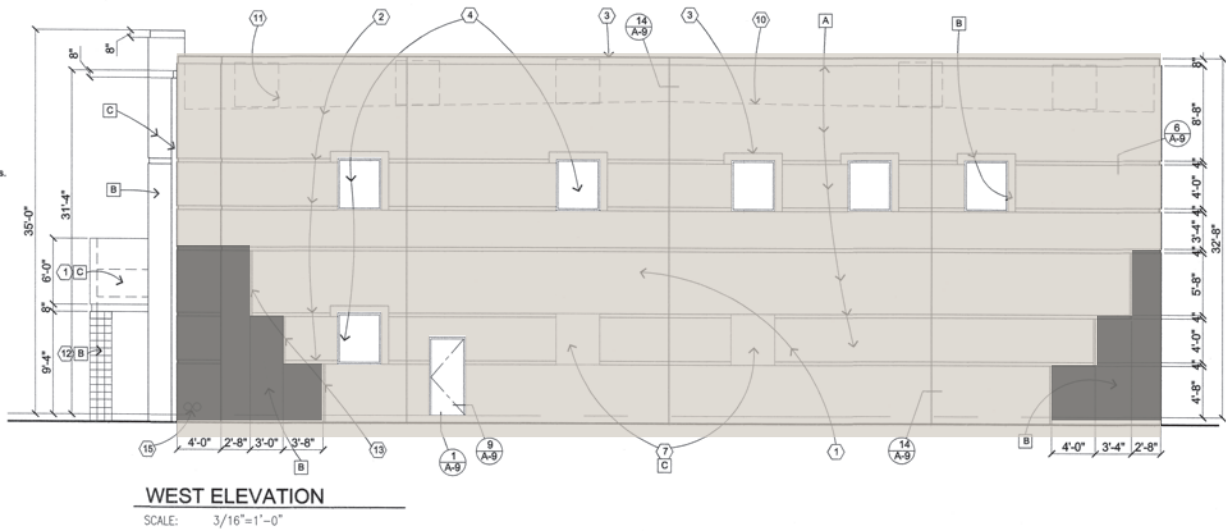
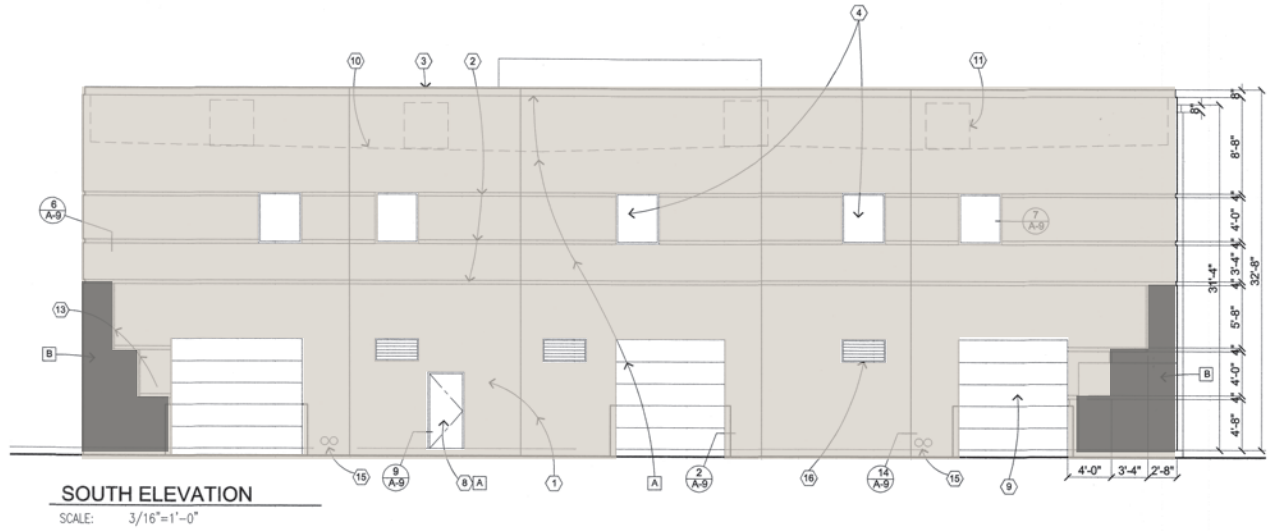

EXTERIOR ELEVATION KEYNOTES

- ① Concrete tilt-up wall panel.
- ② 4"x12" deep reveal.
- ③ 6"x12" deep reveal.
- ④ Heat reflective glass in bronze anodized aluminum frames.
- ⑤ Steel canopy beyond parapet at entry element.
- ⑥ Possible signage.
- ⑦ 12" deep reveal.
- ⑧ Hollow metal door and frame.
- ⑨ Overhead sectional steel door.
- ⑩ Line of roof beyond parapet.
- ⑪ Mechanical unit beyond parapet.
- ⑫ 6" center scored CMU.
- ⑬ 1"x1/2" deep reveal.
- ⑭ 12" high individually mounted reverse pan channel anodized dark bronze helvetica numbers.
- ⑮ Roof drain.
- ⑯ Metal louvers per Mechanical. Paint color [A].
- ⑰ S.E.S. - Paint to match building.

EXTERIOR PAINT COLORS
(Frazee Paints)

- [A] Crisp Khaki, 8233M
- [B] Jericho Brown, 8305D
- [C] Ayers Rock, 7826A
- [D] Desert Edge, 7824M

CITY BUILDING ELEVATION NOTES

- 1. All roof top mechanical equipment shall be completely screened by parapet walls or within roof structure.
- ② All ground mounted mechanical equipment shall be completely screened by screen walls to +1' above unit height with color and texture to match the building.
- ③ Roof mounted communication equipment, including satellite dishes, shall be completely screened by the parapet walls or free standing screen walls.
- ④ Ground mounted communication equipment, including satellite dishes, shall be completely screened by freestanding screen walls to +1' above unit height subject to Development Quality/Compliance approval.
- 5. No exterior ladders that can be visible from offsite are allowed.



W winton architects, inc.
4222 N. 12th Street, Suite 102, Phoenix, Arizona 85014
(602) 230-9778 FAX (602) 265-9739

WA

**NEW BUILDING FOR
REPUBLIC WEST
SCOTTSDALE, ARIZONA
SUN STATE BUILDERS**

Job no. 02128
drawn WDH
approved RBW
date 10/18/02
revisions
① CITY 11/6/02

A-4

**STIPULATION SET
RETAIN FOR RECORDS
APPROVED**

01/30/2024 
DATE APPROVED BY

STAFF APPROVAL # _____ SA _____ COS PLAN #3578-02-2
NATIVE PLANT # 105 NP 2002 39-DR-2002

McDOWELL ROAD

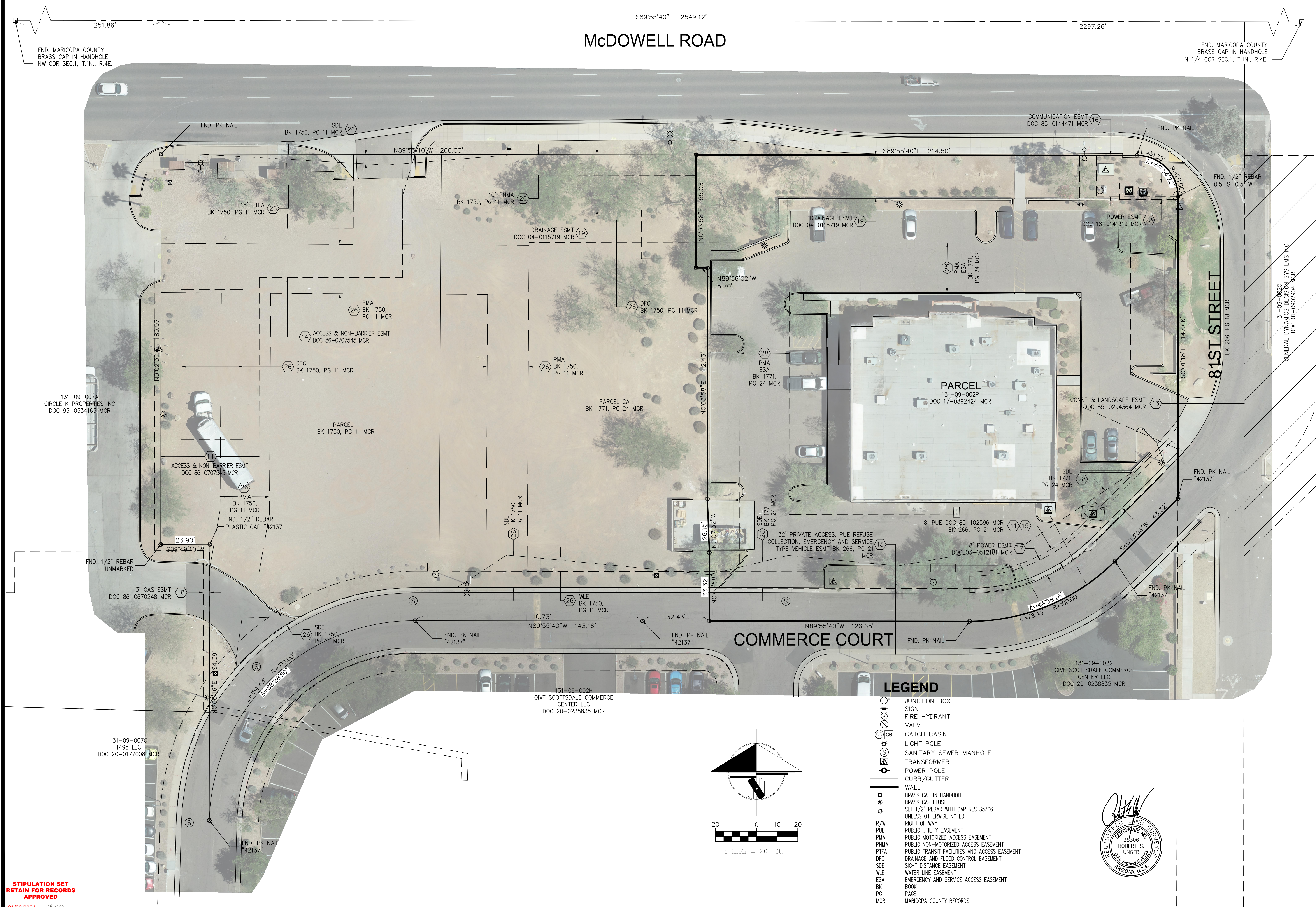

- LEGEND**
- JUNCTION BOX
 - SIGN
 - ⊕ FIRE HYDRANT
 - ⊕ VALVE
 - ⊕ CATCH BASIN
 - ⊕ LIGHT POLE
 - ⊕ SANITARY SEWER MANHOLE
 - ⊕ TRANSFORMER
 - ⊕ POWER POLE
 - ⊕ CURB/GUTTER
 - WALL
 - ⊕ BRASS CAP IN HANDHOLE
 - ⊕ BRASS CAP FLUSH
 - ⊕ SET 1/2" REBAR WITH CAP RLS 35306 UNLESS OTHERWISE NOTED
 - R/W RIGHT OF WAY
 - PUE PUBLIC UTILITY EASEMENT
 - PNMA PUBLIC NON-MOTORIZED ACCESS EASEMENT
 - PTFA PUBLIC TRANSIT FACILITIES AND ACCESS EASEMENT
 - DFC DRAINAGE AND FLOOD CONTROL EASEMENT
 - SDE SIGHT DISTANCE EASEMENT
 - WLE WATER LINE EASEMENT
 - ESA EMERGENCY AND SERVICE ACCESS EASEMENT
 - BK BOOK
 - PG PAGE
 - MCR MARICOPA COUNTY RECORDS

**STIPULATION SET
RETAIN FOR RECORDS
APPROVED**

01/30/2024
DATE APPROVED BY

REV.	DATE	BY

SYNERGY GEOMATICS
2125 E. 5th STREET, #101
TEMPE, AZ 85281
PH: (480) 406-3648
EMAIL: rob@syn-geo.com

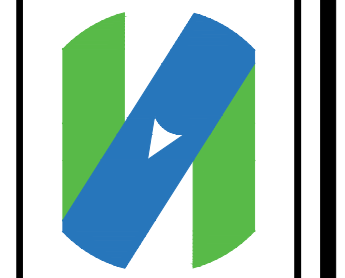

DRAWN: RU
CHECKED: RU
DATE: 12/10/23
DWG: 23138402.dwg

ALTA/NSPS SURVEY
8101 E McDOWELL ROAD
SCOTTSDALE, AZ

PROJECT NO.
23_138
SHEET NUMBER
2 OF 2



Tim Dulany

From: Childers, Sandra <SChilders@Scottsdaleaz.gov>
Sent: Tuesday, November 28, 2023 12:09 PM
To: Tim Dulany
Cc: Dobson, Andrew
Subject: 803-PA-2023 Follow Up Email
Attachments: 803-PA-2023_Checklist.pdf

Follow Up Flag: Follow up
Flag Status: Flagged

EXTERNAL

Hi Tim,

I was lovely meeting with you and Margaret regarding the repaint. Attached to this email is the Development Review Minor (Staff Approval) checklist. When the documents have been gathered, please submit them using the link and login information below:

Link to submit: <https://eservices.scottsdaleaz.gov/bldgresources/PreApp/Login>

Pre-App Number: 803-PA-2023

Keycode: 81V30

Supplemental Links/References:

Grizzle Grey: <https://www.sherwin-williams.com/en-us/color/color-family/neutral-paint-colors/SW7068-grizzle-gray>

Agreeable Grey: <https://www.sherwin-williams.com/en-us/color/color-family/neutral-paint-colors/SW7029-agreeable-gray>

Approved Colors for Neighboring Chipotle :

Material and Color Legend



PPG
Exterior Paint
PPG1085-1 "Blank Canvas"

Field Color:
Wall Color



PPG
Exterior Paint
PPG15-18 "Introspective"

Field Color:
Wall Color



PPG
Exterior Paint
PPG1058-7 "Autumn Ridge"

Field Color:
Wall Color

Thank you,
Sandra Childers
Associate Planner
City of Scottsdale Current Planning Services
schilders@scottsdaleaz.gov

Development Review Minor (SA)

Administrative Staff Approval

Development Application Checklist

**Official Use:**City Staff Contact: Sandra ChildersPhone: 480-312-4214

Staff Signature:

Email: schilders@scottsdaleaz.gov

<input checked="" type="checkbox"/> Completed Application (this form) and Application Fee – \$ <u>115</u> (fee subject to change every July)	<input type="checkbox"/> Exterior Lighting – provide cut sheets, details and photometrics for any proposed lighting.
<input checked="" type="checkbox"/> Affidavit of Authority to Act for Property Owner, letter of authorization, or signature below	<input type="checkbox"/> Copy of Liquor License Application (for all bars or restaurants patio applications)
<input checked="" type="checkbox"/> Narrative – describing nature of request	<input type="checkbox"/> IgCC Requirements (see attached checklist)
<input checked="" type="checkbox"/> Request for Site Visits and/or Inspections form	<input type="checkbox"/> Cross Sections – for all cuts and fills applications
<input type="checkbox"/> Signed Owner Certification Acknowledging Receipt of Notice of Right to Appeal Exactions and Dedications	<input type="checkbox"/> Conceptual Grading & Drainage Plan – show existing, proposed drainage flows, channels, retention, etc.
<input checked="" type="checkbox"/> Elevation Drawings or Color Photo simulations – of additions, buildings, or other changes with materials and colors noted and keyed	<input type="checkbox"/> Floor Plan(s) – show additions, alterations, or new structures. Floor plans shall be dimensioned and clearly delineate existing and proposed construction.
<input checked="" type="checkbox"/> Material Samples – color chips, awning fabric, glazing, etc.	<input type="checkbox"/> Airport Vicinity Development Checklist
<input type="checkbox"/> Site plan indicate the extent and location of additions, buildings and other structures, dimensions of existing and proposed structures, sidewalks, and/or driveways as well as any required setbacks.	<input type="checkbox"/> Landscape Plan – indicate location of existing and new plants, location and dimension of paving, a plant palette with names, symbols, sizes, spacing & quantities, and open space/landscaping calculations.
<input type="checkbox"/> Homeowners or Property Owners Association Approval	<input type="checkbox"/> Request to Submit Concurrent Development Applications
<input checked="" type="checkbox"/> Color photographs of site – include area of request	<input type="checkbox"/> Other: _____

Submittal Requirements:Please submit materials requested below. **All digital files must be uploaded in PDF format.**Project No.: 803 -PA- 2023 Key Code: 81V30Submit digitally at: <https://eservices.scottsdaleaz.gov/bldgresources/Cases/DigitalMenu>Project Name: 8101 E McDowell Road Bldg.Property's Address: 8101 East McDowell Road, Scottsdale, AZ 85257A.P.N.: 131-09-002P

Property's Zoning District Designation:

Application Request: Re-paint exterior of buildingOwner: 8101 EMCD LLCApplicant: Margie Rice - ManagerCompany: 8101 EMCD LLCCompany: 8101 EMCD LLCAddress: 11201 N Tatum Blvd Ste 300, PMB104456, Phoenix, AZ 85028-6039Address: PMB 104456, Phoenix, Arizona 85028-6039Phone: 602-684-6179

Fax:

Phone: 847-477-3314

Fax:

E-mail: member@longfarmsig.comE-mail: ceo@longfarmsig.com

Please indicate in the checkbox below the requested review methodology (please see the descriptions on page 2):

 Enhanced Application Review: I hereby authorize the city of Scottsdale to review this application utilizing the Enhanced Application Review methodology. **Standard Application Review:** I hereby authorize the city of Scottsdale to review this application utilizing the Standard Application Review methodology.

DocuSigned by:

3A9C7AED2D004F0...
Owner Signature

DocuSigned by:

365EDF21138E4F0...
Agent/Applicant Signature

Planning and Development Services

7447 E. Indian School Road, Suite #105, Scottsdale, AZ 85251 • www.ScottsdaleAZ.gov

Affidavit of Authorization to Act for Property Owner



1. This affidavit concerns the following parcel of land:

- a. Street Address: 8101 East McDowell Road, Scottsdale, Arizona
- b. County Tax Assessor's Parcel Number: 131-09-002P
- c. General Location: E of the SEC of Hayden and McDowell Road
- d. Parcel Size: approximately 50,530 square feet of Land.
- e. Legal Description: See Legal Description - attachment

(If the land is a platted lot, then write the lot number, subdivision name, and the plat's recording number and date. Otherwise, write "see attached legal description" and attach a legal description.)

- 2. I am the owner of the land or I am the duly and lawfully appointed agent of the owner of the land and have authority from the owner to sign this affidavit on the owner's behalf. If the land has more than one owner, then I am the agent for all of the owners, and the word "owner" in this affidavit refers to all of them.
- 3. I have authority from the owner to act for the owner before the City of Scottsdale with regard to any and all reviews, zoning map amendments, general plan amendments, development variances, abandonments, plats, lot splits, lot ties, use permits, building permits and other land use regulatory or related matters of every description involving the land, or involving adjacent or nearby lands in which the owner has (or may acquire) an interest, and all applications, dedications, payments, assurances, decisions, agreements, legal documents, commitments, waivers and other matters relating to any of them.
- 4. The City of Scottsdale is authorized to rely on my authority as described in this affidavit until three work days after the day the owner delivers to the Director of the Scottsdale Planning & Development Services Department a written statement revoking my authority.
- 5. I will immediately deliver to the Director of the City of Scottsdale Planning & Development Services Department written notice of any change in the ownership of the land or in my authority to act for the owner.
- 6. If more than one person signs this affidavit, each of them, acting alone, shall have the authority described in this affidavit, and each of them warrant to the City of Scottsdale the authority of the others.
- 7. Under penalty of perjury, I warrant and represent to the City of Scottsdale that this affidavit is true and complete. I understand that any error or incomplete information in this affidavit or any applications may invalidate approvals or other actions taken by the City of Scottsdale, may otherwise delay or prevent development of the land, and may expose me and the owner to other liability. I understand that people who have not signed this form may be prohibited from speaking for the owner at public meetings or in other city processes.

Name (printed)

Margie Rice

Date

12/17, 2023

_____, 20__

_____, 20__

_____, 20__

DocuSigned by:

Signature

Margaret Rice

56BEBF21138E4F0...

Planning and Development Services

7447 E Indian School Road, Suite 105, Scottsdale, AZ 85251 ♦ www.ScottsdaleAZ.gov

Request for Site Visits and/or Inspections

Construction Document Application



This request concerns all property identified in the construction document (plan review) application.

Project Name: 8101 East McDowell Road Bldg.

Project Address: 8101 East McDowell Road, Scottsdale, Arizona 85257

STATEMENT OF AUTHORITY:

1. I am the owner of the property, or I am the duly and lawfully appointed agent of the property and have the authority from the owner to sign this request on the owner's behalf. If the land has more than one owner, then I am the agent for all owners, and the word "owner" refer to them all.
2. I have the authority from the owner to act for the owner before the City of Scottsdale regarding any and all development application regulatory or related matter of every description involving all property identified in the construction document.

STATEMENT OF REQUEST FOR SITE VISITS AND/OR INSPECTIONS

1. I hereby request that the City of Scottsdale's staff conduct site visits and/or inspections of the property identified in the construction document in order to efficiently process the application.
2. I understand that even though I have requested the City of Scottsdale's staff conduct site visits and/or inspections, city staff may determine that a site visit and/or an inspection is not necessary, and may opt not to perform the site visit and/or an inspection.

Property owner /Property owner's agent: Margie Rice Print Name

DocuSigned by:
Margaret Rice
56BEDF21138E4F0... Signature

City Use Only:

Submittal Date: _____ Plan review number: _____

Planning and Development Services
7447 E Indian School Road, Suite 105, Scottsdale, AZ 85251 ♦ www.ScottsdaleAZ.gov



Current Planning Services
Long Range Planning Services

NOTICE OF INSPECTION RIGHTS
A.R.S. § 9-833

You have the right to:

- Have the City staff member present a photo ID.
- Have the City staff member state the purpose for the planning inspection and legal authority to conduct it.
- Know the amount of inspection fees if applicable.
- An on-site representative may accompany the City staff member during the inspection except during confidential interviews and may:
 - Receive copies of any documents taken during the inspection.
 - Receive a split of any samples taken during the inspection.
 - Receive copies of any analysis of the samples taken when available.
- Be informed if statements are being recorded.
- Be given notice that any statements may be used in an inspection report.
- Be presented with a copy of your inspection rights.
- Be notified of the due process rights pertaining to an appeal

You are hereby notified and informed of the following:

- The inspection is conducted pursuant to the authority of A.R.S § 9-462.05. and/or Scottsdale Revised Code, Appendix B, Article I. Section 1.203.
- Any statements made by anyone interviewed during this inspection may be included in the inspection report.
- Information on appeal rights related to this inspection is found under Scottsdale Revised Code, Appendix B, Article I. Section 1.801.
- There is no inspection fee associated with this inspection.

I acknowledge I have been informed of my inspection rights. If I decline to sign this form, the inspector(s) may still proceed with the inspection.

If I have any questions, I may contact the City staff member, Sandra Childers

at the following number, 480-312-4214

Signature: Margaret Rice Date: 12/18/2023

Printed Name: Margie Rice

Check box if signature refused

Copy of Bill of Rights left at: _____

A.R.S § 9-833. Inspections; applicability

- A. A municipal inspector or regulator who enters any premises of a regulated person for the purpose of conducting an inspection shall:
1. Present photo identification on entry of the premises.
 2. On initiation of the inspection, state the purpose of the inspection and the legal authority for conducting the inspection.
 3. Disclose any applicable inspection fees.
 4. Except for a food and swimming pool inspection, afford an opportunity to have an authorized on-site representative of the regulated person accompany the municipal inspector or regulator on the premises, except during confidential interviews.
 5. Provide notice of the right to have:
 - (a) Copies of any original documents taken from the premises by the municipality during the inspection if the municipality is permitted by law to take original documents.
 - (b) A split or duplicate of any samples taken during the inspection if the split or duplicate of any samples, where appropriate, would not prohibit an analysis from being conducted or render an analysis inconclusive.
 - (c) Copies of any analysis performed on samples taken during the inspection.
 6. Inform each person whose conversation with the municipal inspector or regulator during the inspection is tape recorded that the conversation is being tape recorded.
 7. Inform each person interviewed during the inspection that statements made by the person may be included in the inspection report.
- B. On initiation of, or two working days before, an inspection of any premises of a regulated person, except for a food and swimming pool inspection that has up to one working day after an inspection, a municipal inspector or regulator shall provide the following in writing or electronically:
1. The rights described in subsection A of this section.
 2. The name and telephone number of a municipal contact person available to answer questions regarding the inspection.
 3. The due process rights relating to an appeal of a final decision of a municipality based on the results of the inspection, including the name and telephone number of a person to contact within the municipality and any appropriate municipality, county or state government ombudsman.
- C. A municipal inspector or regulator shall obtain the signature of the regulated person or on-site representative of the regulated person on the writing prescribed in subsection B of this section indicating that the regulated person or on-site representative of the regulated person has read the writing prescribed in subsection B of this section and is notified of the regulated person's or on-site representative of the regulated person's inspection and due process rights. The municipality shall maintain a copy of this signature with the inspection report. Unless the regulated person at the time of the inspection is informed how the report can be located electronically, the municipality shall leave a copy with the regulated person or on-site representative of the regulated person. If a regulated person or on-site representative of the regulated person is not at the site or refuses to sign the writing prescribed in subsection B of this section, the municipal inspector or regulator shall note that fact on the writing prescribed in subsection B of this section.
- D. A municipality that conducts an inspection shall give a copy of, or provide electronic access to, the inspection report to the regulated person or on-site representative of the regulated person either:
1. At the time of the inspection.
 2. Notwithstanding any other state law, within thirty working days after the inspection.
 3. As otherwise required by federal law.

- E. The inspection report shall contain deficiencies identified during an inspection. Unless otherwise provided by law, the municipality may provide the regulated person an opportunity to correct the deficiencies unless the municipality determines that the deficiencies are:
 - 1. Committed intentionally.
 - 2. Not correctable within a reasonable period of time as determined by the municipality.
 - 3. Evidence of a pattern of noncompliance.
 - 4. A risk to any person, the public health, safety or welfare or the environment.
- F. If the municipality allows the regulated person an opportunity to correct the deficiencies pursuant to subsection E of this section, the regulated person shall notify the municipality when the deficiencies have been corrected. Within thirty working days of receipt of notification from the regulated person that the deficiencies have been corrected, the municipality shall determine if the regulated person is in substantial compliance and notify the regulated person whether or not the regulated person is in substantial compliance, unless the determination is not possible due to conditions of normal operations at the premises. If the regulated person fails to correct the deficiencies or the municipality determines the deficiencies have not been corrected within a reasonable period of time, the municipality may take any enforcement action authorized by law for the deficiencies.
- G. A municipality's decision pursuant to subsection E or F of this section is not an appealable municipal action.
- H. At least once every month after the commencement of the inspection, a municipality shall provide the regulated person with an update, in writing or electronically, on the status of any municipal action resulting from an inspection of the regulated person. A municipality is not required to provide an update after the regulated person is notified that no municipal action will result from the municipality's inspection or after the completion of municipal action resulting from the municipality's inspection.
- I. This section does not authorize an inspection or any other act that is not otherwise authorized by law.
- J. This section applies only to inspections necessary for the issuance of a license or to determine compliance with licensure requirements. This section does not apply:
 - 1. To criminal investigations and undercover investigations that are generally or specifically authorized by law.
 - 2. If the municipal inspector or regulator has reasonable suspicion to believe that the regulated person may be or has been engaged in criminal activity.
 - 3. Inspections by a county board of health or a local health department pursuant to section 36-603.
- K. If a municipal inspector or regulator gathers evidence in violation of this section, the violation shall not be a basis to exclude the evidence in a civil or administrative proceeding, if the penalty sought is the denial, suspension or revocation of the regulated person's license or a civil penalty of more than one thousand dollars.
- L. Failure of a municipal employee to comply with this section:
 - 1. Constitutes cause for disciplinary action or dismissal pursuant to adopted municipal personnel policy.
 - 2. Shall be considered by the judge and administrative law judge as grounds for reduction of any fine or civil penalty.
- M. A municipality may adopt rules or ordinances to implement this section.
- N. This section:
 - 1. Shall not be used to exclude evidence in a criminal proceeding.
 - 2. Does not apply to a municipal inspection that is requested by the regulated person.

Appeals of Dedication, Exactions or Zoning Regulations



Rights of Property Owner

In addition to the other rights granted to you by the U.S. and Arizona Constitution, federal and state law and city ordinances or regulations, you are hereby notified of your right to appeal the following City actions relating to your property:

- 1) Any dedication or exaction which is required of you by an administrative agency or official of the city as a condition of granting approval of your request to use, improve or develop your real property. This appeal right does not apply to a dedication or exaction required as part of a city legislative act (for example a zoning ordinance) when an administrative agency or official has no discretion to determine the dedication or exaction.
- 2) The adoption or amendment of a zoning regulation that creates a taking of property in violation of Arizona and federal court decision.

Appeal Procedure

The appeal must be in writing and specify the City action appealed and the date final action was taken, and must be filed with or mailed to the hearing officer designated by the city within 30 days after the final action is taken

- No fee will be charged for filing
- The city Attorney's Office will review the appeal for compliance with the above requirements, and will notify you if your appeal does not comply
- Eligible appeals will be forwarded to the hearing officer, and a hearing will be scheduled within 30 days of receipt by the hearing officer of your request. Ten days notice will be given to you of the date, time and place of the hearing unless you indicate that less notice is acceptable to you.
- The City will submit a takings impact report to the hearing officer.
- In an appeal from a dedication or exaction, the City will bear the burden of proving that the dedication or exaction to be imposed on your property bears an essential nexus between the requirement and a legitimate governmental interest and that the proposed dedication or exaction is roughly proportional to the impact of the use, improvement or development you proposed.
- In an appeal from the adoption or amendment of a zoning regulation, the City will bear the burden of proving that any dedication or exaction requirement in the zoning regulation is roughly proportional to the impact of the proposed use, improvement, or development, and that the zoning regulation does not create a taking of property in violation of Arizona and federal court cases.
- The hearing officer must render his decision within five working days after the appeal is heard.
- The hearing officer can modify or delete a dedication or exaction or, in the case of an appeal from a zoning regulation, transmit a recommendation to the City Council.
- If you are dissatisfied with the decision of the hearing officer, you may file a complaint for a trial nevo with the Superior Court within 30 days of the hearing officer's decision.

For questions, you may contact:

City's Attorney's Office
 3939 Drinkwater Blvd.
 Scottsdale, AZ 85251
 480-312-2405

Address your appeal to:

Hearing Officer, C/O City Clerk
 3939 Drinkwater Blvd
 Scottsdale, AZ 85251

Please be aware that City Staff cannot give you legal advice. You may wish, but are not required, to hire an attorney to represent you in an appeal.

Planning and Development Services

7447 E. Indian School Road, Suite 105, Scottsdale, AZ 85251 ♦ www.ScottsdaleAZ.gov

**Owner Certification
Acknowledging Receipt
Of
Notice Of Right To Appeal
Exactions And Dedications**

I hereby certify that I am the owner of property located at:

8101 East McDowell Road, Scottsdale, Arizona 85257

(address where development approval, building permits, or city required improvements and dedications are being required)

and hereby certify that I have received a notice that explains my right to appeal all exactions and/or dedications required by the City of Scottsdale as part of my property development on the parcel listed in the above address.

DocuSigned by:

Bill Langhofer

Signature of Property Owner

12/18/2023

Date