

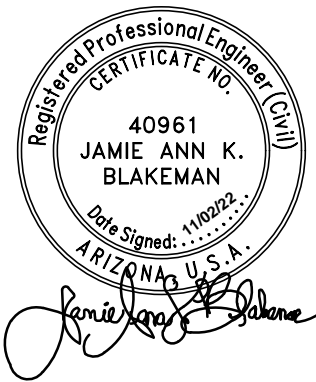

Gold Dust

Transportation Impact & Mitigation Analysis



Prepared for:



High Street Residential
2575 East Camelback Road, Suite 400
Phoenix, AZ 85016

Prepared by:



Lokahi, LLC
10555 N. 114th Street,
Suite 105
Scottsdale, AZ 85259

Project Number: 21.5257
November 2, 2022



TABLE OF CONTENTS:

- 1. Introduction and Executive Summary1**
 - 1.1. Purpose of Report and Study Objectives1
 - 1.2. Executive Summary.....1
- 2. Proposed Development4**
- 3. Area Conditions8**
 - 3.1. Study Roadway Segments.....8
 - 3.2. Study Intersections9
 - 3.3. Surrounding Area Land Use.....9
 - 3.4. Site Accessibility 10
 - 3.5. Collision Rates 11
 - 3.6. Collision History..... 11
- 4. Existing Conditions.....13**
 - 4.1. Existing Land Use13
 - 4.2. Existing Traffic Counts13
 - 4.3. Existing Roadway Capacity..... 14
 - 4.4. Existing Capacity Analysis..... 16
- 5. Projected Traffic..... 19**
 - 5.1. Trip Generation..... 19
 - 5.2. Trip Generation Comparison 20
 - 5.3. Trip Distribution and Assignment 20
- 6. Future Conditions (Year 2025)..... 23**
 - 6.1. Year 2025 No Build Traffic Volumes 23
 - 6.2. Year 2025 Build Traffic Volumes 23
 - 6.3. Year 2025 No Build Capacity Analysis..... 24
 - 6.4. Year 2025 Build Capacity Analysis 25
- 7. Turn Lane Analysis.....31**
 - 7.1. Right Turn Lane Warrant31
 - 7.2. Queue Analysis 33
- 8. Gold Dust Access34**
- 9. Recommendations & Conclusions.....36**





FIGURES:

Figure 1 – Vicinity Map5
 Figure 2 – Site Plan.....6
 Figure 3 – Study Area7
 Figure 4 – Existing Traffic Volumes 15
 Figure 5 – Existing Capacity Analysis 18
 Figure 6 – Trip Distribution.....21
 Figure 7 – Site Traffic Volumes 22
 Figure 8 – Year 2025 No Build Traffic Volumes..... 27
 Figure 9 – Year 2025 Build Traffic Volumes28
 Figure 10 – Year 2025 No Build Capacity Analysis.....29
 Figure 11 – Year 2025 Build Capacity Analysis30
 Figure 12 – Gold Dust Access 35

TABLES:

Table 1 – Collision Rates - Study Roadway Segment..... 11
 Table 2 – Level of Service Criteria 16
 Table 3 – Existing Level of Service and Delay17
 Table 4 – Trip Generation – Proposed Development..... 19
 Table 5 – Trip Generation (Existing Land Use)20
 Table 6 – Trip Generation Comparison20
 Table 7 – Trip Generation (Adjacent Land Uses).....24
 Table 8 – Year 2025 Level of Service and Delay26
 Table 9 –Right Turn Lane Criteria Analysis 31
 Table 10 – Queue Analysis33

APPENDICES:

Appendix A – Proposed Site Plan..... A
 Appendix B – Collision History B
 Appendix C – Parcel InformationC
 Appendix D – Traffic Count Data D
 Appendix E – Signal Timing E
 Appendix F – Existing Capacity Analysis..... F
 Appendix G – Trip Generation G
 Appendix H – MAG Socioeconomic Projections H
 Appendix I – Year 2025 No Build Capacity AnalysisI
 Appendix J – Year 2025 Build Capacity Analysis..... J





1. INTRODUCTION AND EXECUTIVE SUMMARY

1.1. PURPOSE OF REPORT AND STUDY OBJECTIVES

Lōkahi, LLC (Lōkahi) was retained by High Street Residential to complete a Transportation Impact & Mitigation Analysis for the proposed Gold Dust development located on the southwest corner of Gold Dust Avenue and Scottsdale Road, in Scottsdale, Arizona. The objective of this Transportation Impact & Mitigation Analysis is to analyze the traffic related impacts of the proposed development to the adjacent roadway network. See **Figure 1** for the vicinity map.

1.2. EXECUTIVE SUMMARY

The proposed Gold Dust development will be located on the southwest corner of Gold Dust Avenue and Scottsdale Road in Scottsdale, Arizona. The proposed Gold Dust development will be comprised of a total of 212 multifamily residential units, of which, there will be 159 one-bedroom, 51 two-bedroom, and 2 three-bedrooms units. Additionally, an approximate 2,500 square foot fitness/yoga studio will be located on-site that will be open to the general public.

This Transportation Impact and Mitigation Analysis includes:

- Level of service analysis of existing conditions for the weekday AM and PM peak hours
- Trip Generation for the existing development
- Trip Generation for the proposed development
- Trip Generation Comparison
- Level of service analysis for the opening year (2025) weekday AM and PM peak hours
 - 2025 No Build
 - 2025 Build

The following are the intersections included in this study:

- Gold Dust Avenue and Driveway A (1)
- Gold Dust Avenue and Scottsdale Road (2)
- Scottsdale Road and Driveway B (3)
- Scottsdale Road and Acacia Driveway (4)

Existing Capacity Analysis

The AM and PM peak hour existing conditions capacity analysis were completed for the existing study intersections. The results of the capacity analysis reveal the following location with an existing level of service (LOS) E or F:

Gold Dust Avenue and Scottsdale Road (2)

- Southbound shared through-right AM and PM peak hours operate at LOS E





Trip Generation

The proposed development is anticipated to generate 1,501 weekday trips with 88 occurring during the AM peak hour and 117 trips during the PM peak hour.

Trip Generation – Proposed Development

Land Use	ITE Code	Qty	Unit	Weekday	AM Peak Hour			PM Peak Hour		
				Total	Total	In	Out	Total	In	Out
Multifamily Housing (Low-Rise)	220	212	Dwelling Units	1,429	85	20	65	108	68	40
Health/Fitness Club	492	2.5	1000 SF GFA	72	3	2	1	9	5	4
Total				1,501	88	22	66	117	73	44

Trip Generation Comparison

The build-out of the proposed Gold Dust development is anticipated to generate 1 (0.1%) fewer weekday trips, with 23 (35.2%) more trips during the AM peak hour, and 65 (35.6%) fewer trips during the PM peak hour than the existing 27,581 square-foot commercial building.

Trip Generation Comparison

Land Use	ITE Code	Qty	Unit	Weekday	AM Peak Hour			PM Peak Hour		
				Total	Total	In	Out	Total	In	Out
Multifamily Housing (Low-Rise)	220	212	Dwelling Units	1,429	85	20	65	108	68	40
Health/Fitness Club	492	3	1000 SF GFA	72	3	2	1	9	5	4
Proposed Development Total				1,501	88	22	66	117	73	44
Strip Retail Plaza (<40k)	822	27,581	1000 SF GLA	1,502	65	40	25	182	91	91
Existing Land Use Total				1,502	65	40	25	182	91	91
Difference				-1	23	-18	41	-65	-18	-47
Percent Difference				-0.1%	35.2%	-45.0%	163.0%	-35.6%	-19.8%	-51.5%



Future Conditions - Year 2025

The Gold Dust development is anticipated to be constructed and ready to open in the year 2025. Therefore, year 2025 analyses was completed with and without the build out of the proposed development. An annual growth rate of 2.0% was applied to the existing traffic volumes.

A capacity analysis was completed for both the AM and PM peak hours for year 2025, with and without the build out of the proposed development. All movements operate at a LOS D or better or are maintained at the year 2025 no build level of service.

Recommendations

The existing Driveway A located approximately 400 feet west of Scottsdale Road will be slightly modified to align with the driveway on the north side of Gold Dust Avenue. Aligned driveways are ideal as they minimize confusion and overlapping of vehicular paths, specifically left turn movements. This driveway will continue to operate as it does today as a full access driveway.

Additionally, an existing full access driveway located along Gold Dust Avenue, approximately 600 feet west of Scottsdale Road will be removed. This will reduce the number of conflict points along this stretch of roadway.

It is anticipated that the proposed Gold Dust development will operate at acceptable levels of service and the access modifications described above will improve the overall operation of Gold Dust Avenue in this area.



2. PROPOSED DEVELOPMENT

The proposed development is located on the southwest corner of Gold Dust Avenue and Scottsdale Road in the City of Scottsdale, Arizona. The proposed Gold Dust development will be comprised of a total of 212 multifamily residential units, of which, there will be 159 one-bedroom, 51 two-bedroom, and 2 three-bedrooms units. Additionally, an approximate 2,500 square foot fitness/yoga studio will be located on-site that is anticipated to be open to the general public.

See **Figure 2** and **Appendix A** for the proposed site plan.

There are three (3) access points to the proposed site. All three (3) access points are existing driveways that provide shared access to adjacent developments.

Gold Dust Avenue and Driveway A (1) is an existing driveway located approximately 400 feet west of Scottsdale Road (centerline to centerline) and will be a full access driveway. This will remain a shared-access driveway.

Scottsdale Road and Driveway B (3) is an existing driveway located approximately 330 feet south of Gold Dust Avenue (centerline to centerline) and will be a right-in and right-out only driveway. This will remain a shared-access driveway.

Scottsdale Road and Acacia Driveway (4) is an existing driveway located approximately 650 feet south of Gold Dust Avenue (centerline to centerline) and will be a full access driveway. This will remain a shared-access driveway.

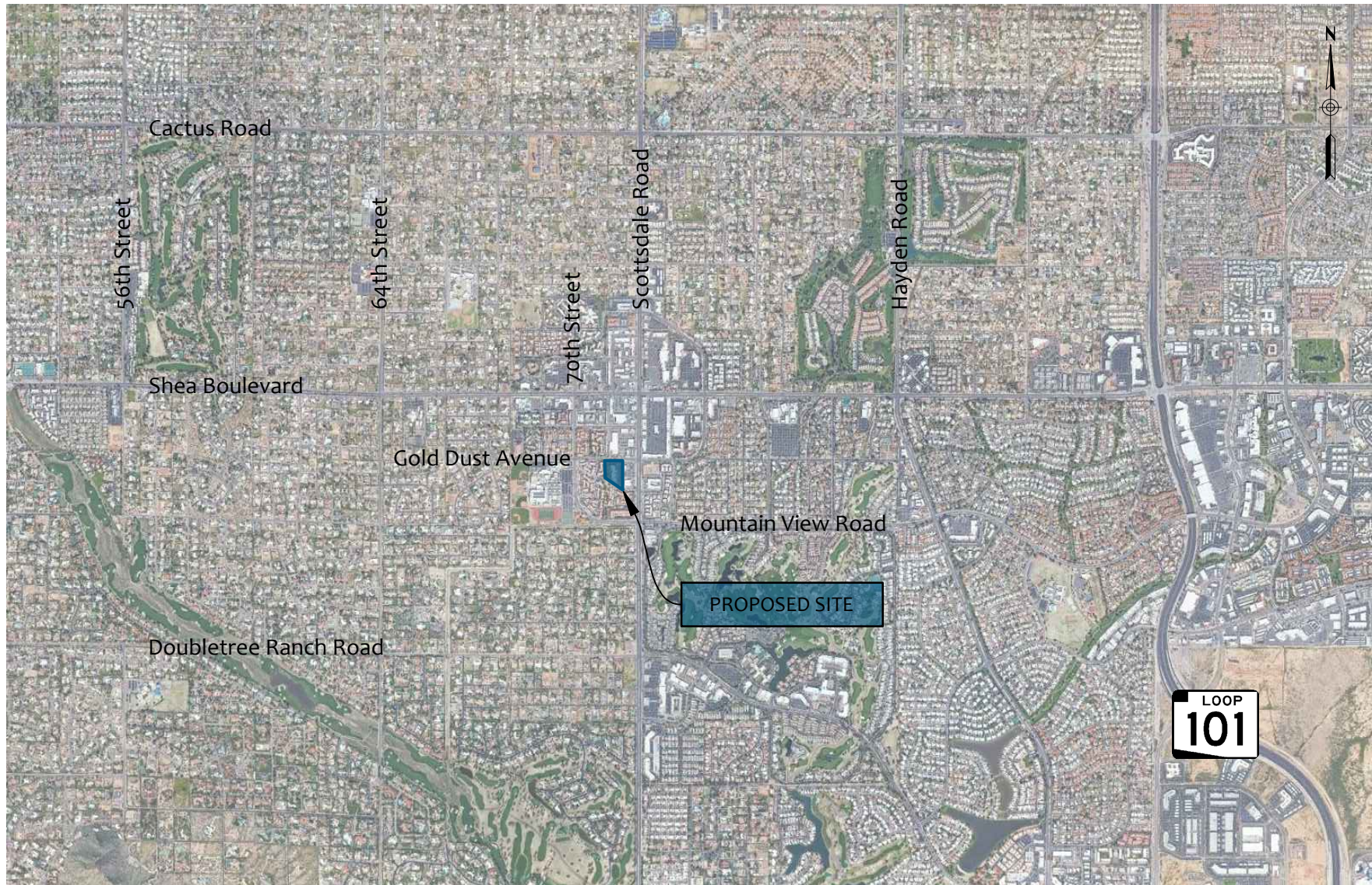

FIGURE 1 | VICINITY MAP

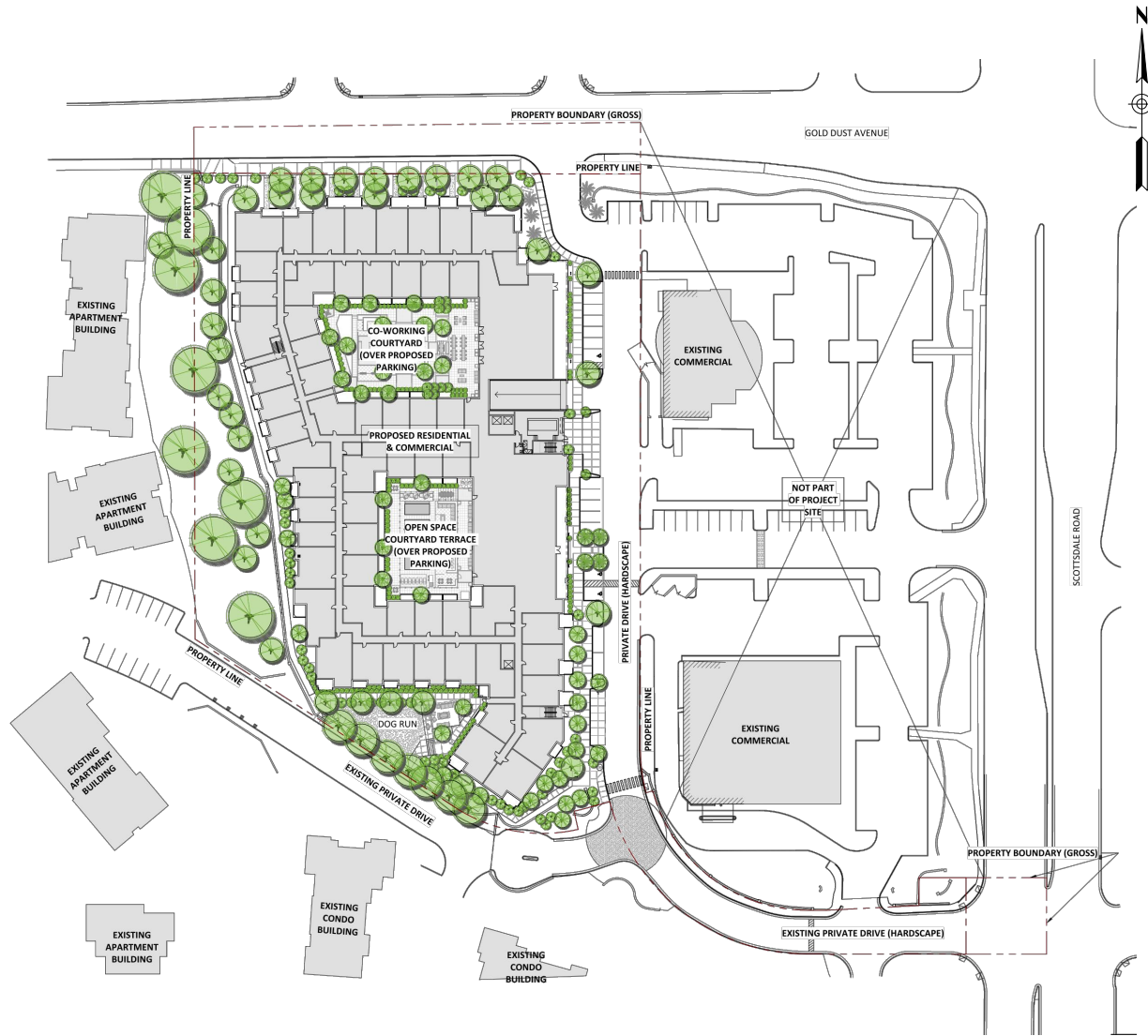

FIGURE 2 | SITE PLAN



LEGEND

- ◆ Intersection

FIGURE 3 | STUDY AREA



3. AREA CONDITIONS

The study area is located in the City of Scottsdale, Arizona. **Sections 3.1** and **3.2** provide detailed descriptions of the study roadway segments and intersections. See **Figure 3** for study area.

3.1. STUDY ROADWAY SEGMENTS

Scottsdale Road is a north-south roadway that provides three (3) travel lanes in each direction of travel, with a center raised median. The City of Scottsdale classifies Scottsdale Road as a major arterial, according to the *City of Scottsdale Transportation Master Plan*, dated July 5, 2016. The City of Scottsdale's 2020 *Average Daily Segment Traffic (ADT) Volumes* map reports an ADT of 28,200 and 39,300 vehicles per day (vpd) along Scottsdale Road, south and north of Shea Boulevard, respectively. There is a posted speed limit of 40 miles per hour (mph).

Gold Dust Avenue is an east-west roadway that generally provides one (1) travel lanes for each direction of travel, center two-way left turn lane, west of Scottsdale Road. East of Scottsdale Road, Gold Dust Avenue provides two (2) travel lanes for each direction of travel, with intermittent center two-way left turn lane and raised median. Approximately one-quarter of a mile east of Scottsdale Road, Gold Dust Avenue becomes 74th Street, which generally runs north-south. Similarly, approximately six-tenths of a mile to the west of Scottsdale Road, Gold Dust Avenue terminates at 68th Street. The City of Scottsdale classifies Gold Dust Avenue as a major collector, east of Scottsdale Road, according to the *City of Scottsdale Transportation Master Plan*, dated July 5, 2016. There is a posted speed limit of 30 mph and 35 mph, west and east of Scottsdale Road, respectively.



3.2. STUDY INTERSECTIONS

Gold Dust Avenue and Driveway A (1) currently operates as a two-way stop-controlled intersection, with the stop control on the northbound and southbound approaches. The northbound and southbound approaches each provide one (1) shared left-through-right turn lane. The eastbound and westbound approaches each provide one (1) dedicated left turn lane (via a center two-way left turn lane) and one (1) shared through-right turn lane.

Gold Dust Avenue and Scottsdale Road (2) currently operates a signalized intersection. The northbound approach provides one (1) dedicated left turn lane, three (3) through lanes, and one (1) dedicated right turn lane. The southbound approach provides one (1) dedicated left turn lane, two (2) through lanes, and one (1) shared through-right turn lane. The eastbound approach provides one (1) dedicated left turn lane, one (1) through lane, and one (1) dedicated right turn lane. The westbound approach provides one (1) dedicated left turn lane, one (1) through lane, and one (1) shared through-right turn lane.

Scottsdale Road and Driveway B (3) currently operates as a two-way stop-controlled intersection, with the stop control on the eastbound and westbound approaches. Driveway B is an existing right-in and right-out driveway. The northbound approach provides two (2) through lanes and one (1) shared through-right turn lane. The southbound approach provides two (2) through lanes and one (1) shared through-right turn lane. The eastbound and westbound approaches each provide one (1) dedicated right turn lane.

Scottsdale Road and Acacia Driveway (4) currently operates as a two-way stop-controlled intersection, with the stop control on the eastbound and westbound approaches. The northbound approach provides one (1) dedicated left turn lane, three (3) through lanes, and one (1) dedicated right turn lane. The southbound approach provides one (1) dedicated left turn lane, two (2) through lanes, and one (1) shared through-right turn lane. The eastbound and westbound approaches each provide one (1) shared left-through-right turn lane.

3.3. SURROUNDING AREA LAND USE

The proposed development is located in Scottsdale, Arizona. The proposed development is bordered by Gold Dust Avenue to the north, the Mosaic Apartments to the west, the Verona Condominium Homes to the south, and CVS Pharmacy and California Pizza Kitchen to the east. Chaparral High School is located approximately 700 feet west of the proposed site, at the southwest corner of Gold Dust Avenue and 70th Street. The remaining vicinity area is generally occupied by residential and commercial land uses.



3.4. SITE ACCESSIBILITY

Roadway System

The study area is located in the City of Scottsdale, Arizona approximately two (2) miles west of State Route 101 (SR 101). This route provides regional access to the Phoenix metropolitan area. Within the vicinity of the proposed site there is a well-developed roadway network.

Pedestrian Facilities

Continuous sidewalks are generally provided along the study roadway segments within the study area.

Marked crosswalks are provided along each crossing at the intersection of Gold Dust Avenue and Scottsdale Road (2).

Bicycle Facilities

Marked on-street bike lanes are provided in each direction of travel along Scottsdale Road and Gold Dust Avenue, within the study area. However, west of 70th Street, Gold Dust Avenue does not provide marked bike lanes.

Transit Facilities

Within the study area, Valley Metro Route 72 operates along Scottsdale Road. There are two (2) bus stops for Route 72 in the immediate area. There is one (1) bus stop provided on the southwest corner of Gold Dust Avenue and Scottsdale Road (2). An additional bus stop is located along the east side of Scottsdale Road approximately 200-feet south of Gold Dust Avenue.

Additionally, Valley Metro Route 80 operates along Shea Boulevard.



3.5. COLLISION RATES

The City of Scottsdale’s 2020 Traffic Volume & Collision Report provides collision rate and traffic volume information on major roadway segments and at major intersections within the City. Segment collisions are collisions that occur on a major street more than 100 feet from the major intersections that define the segment, including at minor intersections within the segment. Intersection collisions are collisions that occur at or within 100 feet of a major intersection. The collision rate and city-wide ranking for study roadway segments are shown in **Table 1**.

Table 1 – Collision Rates - Study Roadway Segment

Segment	From	To	Collision Rate	Rank
Scottsdale Road	Mountain View Road	Shea Boulevard	3.87	21
2020 City of Scottsdale Average Segment Collision Rate			1.36	

Collision rates for the study intersections are not provided in the City of Scottsdale’s 2020 Traffic Volume & Collision Report.

3.6. COLLISION HISTORY

The most recent 3-year collision history, from January 2019 to December 2021, was obtained from the City of Scottsdale. See **Appendix B** for collision data. The data included the following intersections and segments:

- Gold Dust Avenue and Scottsdale Road (2)
- Gold Dust Avenue, 70th Street to Scottsdale Road
- Scottsdale Road, Gold Dust Avenue to Mountain View Road

Gold Dust Avenue and Scottsdale Road (2)

During the three-year period, there were a total of 27 reported collisions at the intersection of Gold Dust Avenue and Scottsdale Road (2). Of the 27 collisions, there were 8 angle, 8 left turn, 5 rear end, 4 sideswipe same direction, 1 head on, and 1 unknown collision(s). There was a total of 11 failed to yield the right-of-way, 4 disregarded traffic signal, 3 unknown, 3 no improper action, 2 unsafe lane change, 2 other, 1 speed too fast for conditions, and 1 followed too closely collisions(s).

Gold Dust Avenue, 70th Street to Scottsdale Road

During the three-year period, there were a total of 4 reported collisions along the segment of Gold Dust Avenue, between 70th Street and Scottsdale Road. Of the 4 collisions, there were 3 angle and 1 single vehicle collision(s). Of which, 2 were speed too fast for conditions, 1 made improper turn, and 1 unknown.





Scottsdale Road, Gold Dust Avenue to Mountain View Road

During the three-year period, there were a total of 14 reported collisions along the segment of Scottsdale Road, between Gold Dust Avenue and Mountain View Road. Of the 14 collisions, there were 6 rear end, 5 sideswipe same direction, 1 angle, 1 single vehicle, and 1 other collision(s). Of which, 5 were speed too fast for conditions, 3 failed to yield the right-of-way, 1 unsafe lane change, 1 exceed lawful speed, 1 made improper turn, 1 failed to keep in proper lane, 1 other, and 1 unknown.



4. EXISTING CONDITIONS

4.1. EXISTING LAND USE

According to the Maricopa County Assessor, the approximate 4.76-acre site is a currently occupied by an approximate 27,581 square-foot commercial building. The site is currently zoned for Central Business (C-2) land uses. This zoning is intended to accommodate shopping and service needs for nearby neighborhoods. See **Appendix C** for detailed parcel information.

4.2. EXISTING TRAFFIC COUNTS

A local data collection firm, All Traffic Data, was utilized to collect traffic counts. On Tuesday, March 1, 2022, turning movement counts were obtained from 7:00 to 9:00 am and from 4:00 to 6:00 pm at the following locations:

- Gold Dust Avenue and Driveway A (1)
- Gold Dust Avenue and Scottsdale Road (2)
- Scottsdale Road and Driveway B (3)
- Scottsdale Road and Acacia Driveway (4)

Additionally, on Tuesday, March 1, 2022, bi-directional tube counts for 24-hours in 15-minute intervals were collected along the following roadway segments:

- Scottsdale Road, south of Gold Dust Avenue
- Gold Dust Avenue, west of Scottsdale Road

The turning movement counts were then analyzed for the highest 1-hour within each time period. The following peak hours were analyzed throughout this study.

AM Peak Hour	7:30 am – 8:30 am
PM Peak Hour	4:45 pm – 5:45 pm

The City of Scottsdale’s citywide seasonal adjustment factors were used to adjust the traffic counts. The traffic volumes were adjusted based on the month the counts were taken. Therefore, the recorded traffic volumes were divided by a factor of 1.04.

The recorded turning movement counts indicate that some u-turns movements were performed at study intersections. These u-turn volumes were added to the respective left turn movement volumes for the purposes of this study.

See **Appendix D** for detailed count data. See **Figure 4** for the existing adjusted AM and PM peak hour weekday traffic volumes.



4.3. EXISTING ROADWAY CAPACITY

At the request of the City of Scottsdale, the existing traffic volumes along the roadway segments in the area was completed.

As discussed in **Section 4.2**, bi-directional tube counts were collected at the following locations, and resulted in the following daily traffic volumes:

- Scottsdale Road, south of Gold Dust Avenue 31,600 vpd
- Gold Dust Avenue, west of Scottsdale Road 3,400 vpd

Additionally, the City of Scottsdale’s 2020 *Average Daily Segment Traffic (ADT) Volumes* map reports the following traffic counts along Shea Boulevard:

- Shea Boulevard, east of Scottsdale Road 31,300 vpd
- Shea Boulevard, west of Scottsdale Road 35,400 vpd

Scottsdale Road

As mentioned in **Section 3.1**, Scottsdale Road is classified as a major arterial. The City of Scottsdale 2018 *Design Standards & Policies Manual* Section 5-3.101 indicates major arterials with the urban character are intended to serve a range of traffic volumes with an upper range of 55,000 vpd. With the recorded traffic count of 31,600 vpd, Scottsdale Road, south of Gold Dust Avenue is currently operating at approximately 57.5% capacity.

Gold Dust Avenue

As mentioned in **Section 3.1**, Gold Dust Avenue, east of Scottsdale Road, is classified as a major collector. Gold Dust Avenue, west of Scottsdale Road, is currently unclassified. With one (1) travel lane in each direction of travel, Gold Dust Avenue, west of Scottsdale Road, resembles the minor collector with the urban character. The City of Scottsdale 2018 *Design Standards & Policies Manual* Section 5-3.101 indicates minor collectors with the urban character are intended to serve a range of traffic volumes with an upper range of 15,000 vpd. With the recorded traffic count of 3,400 vpd, Gold Dust Avenue, west of Scottsdale Road, is currently operating at approximately 22.7% capacity.

Shea Boulevard

The City of Scottsdale classifies Shea Boulevard as a major arterial, according to the *City of Scottsdale Transportation Master Plan*, dated July 5, 2016. The City of Scottsdale 2018 *Design Standards & Policies Manual* Section 5-3.101 indicates major arterials with the urban character are intended to serve a range of traffic volumes with an upper range of 55,000 vpd. As discussed above, previously recorded traffic counts along Shea Boulevard indicate 31,300 vpd and 35,400 vpd, east and west of Scottsdale Road respectively. Therefore, Shea Boulevard is currently operating at approximately 56.9% and 64.4% capacity, east of west of Scottsdale Road, respectively.

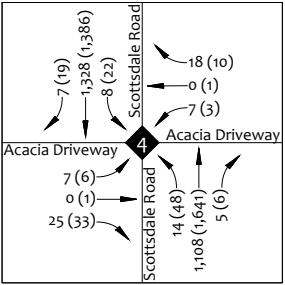
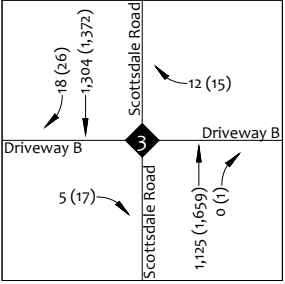
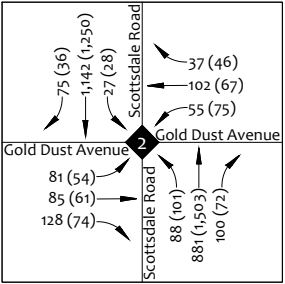
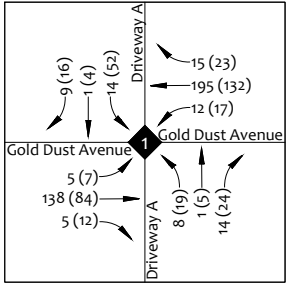
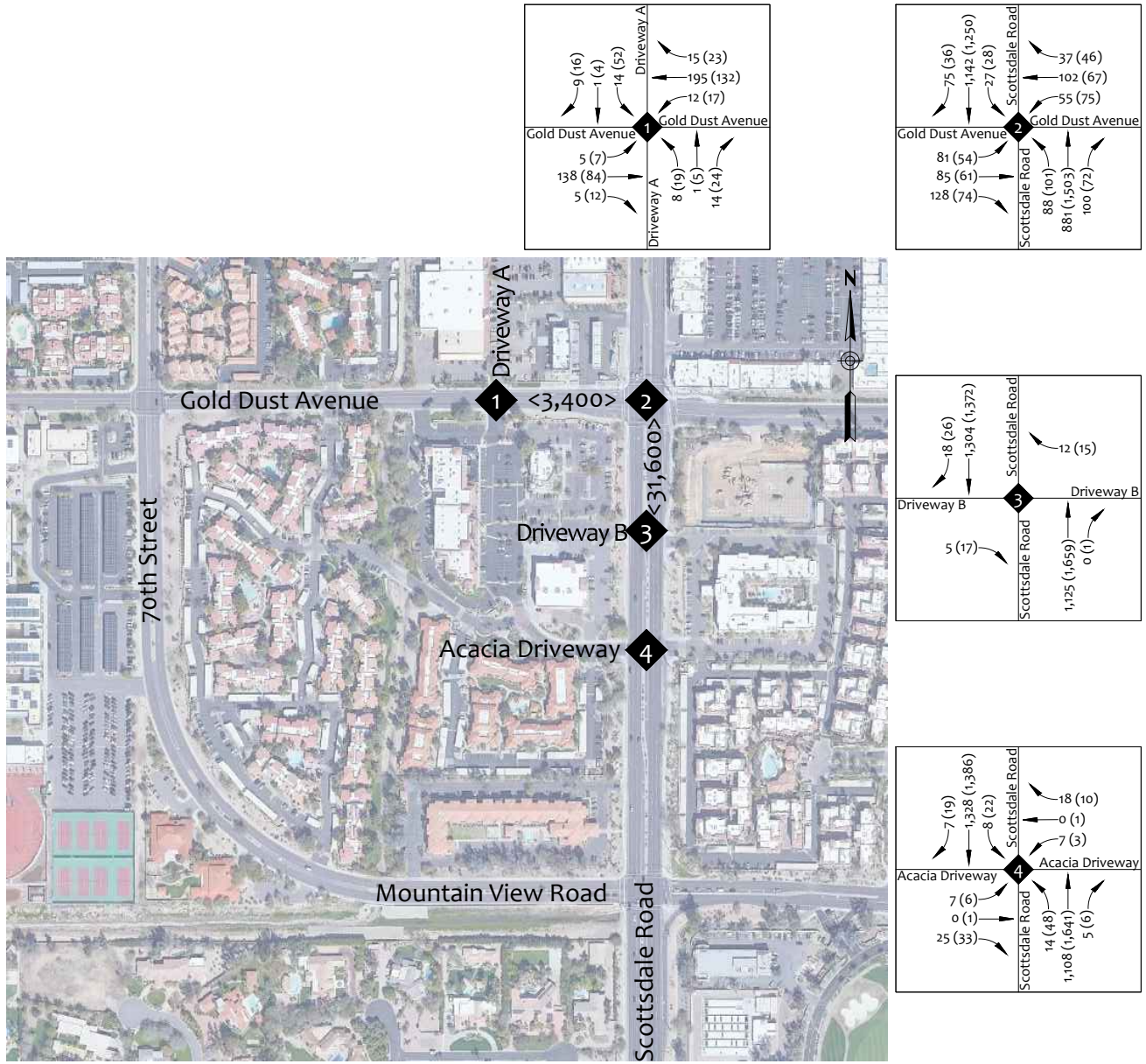

FIGURE 4 | EXISTING TRAFFIC VOLUMES



4.4. EXISTING CAPACITY ANALYSIS

The existing conditions capacity analysis was completed for the existing study intersections. The capacity and level of service for the study area intersections were evaluated using the methodology presented in the 6th Edition of the Highway Capacity Manual (HCM). Traffic analysis software, Synchro Version 11, was used to perform the analyses using the signal timing provided by the City of Scottsdale. The existing peak hour factor (PHF) was used. However, if the existing PHF was greater than 0.92, the PHF was defaulted to 0.92. See **Appendix E** for the existing signal timing.

Table 2 is from the 6th Edition of the Highway Capacity Manual Exhibit 20-2, which lists the Level of Service (LOS) thresholds for signalized and unsignalized intersections.

Table 2 – Level of Service Criteria

Level of Service (LOS)	Control Delay per Vehicle (s/veh)	
	Signalized Intersection	Unsignalized Intersection
A	≤ 10	0 - 10
B	> 10-20	> 10-15
C	> 20-35	> 15-25
D	> 35-55	> 25-35
E	> 55-80	> 35-50
F	> 80	> 50

The results of the capacity analysis reveal the following locations with an existing level of service (LOS) E or F:

Gold Dust Avenue and Scottsdale Road (2)

- Southbound shared through-right AM and PM peak hours operate at LOS E

The existing AM and PM peak hour level of service and delay for the study intersections are shown in **Table 3**.

See **Figure 5** for the existing AM and PM peak hour capacity analysis. The detailed capacity analysis sheets can be found in **Appendix F**.



Table 3 – Existing Level of Service and Delay

Intersection	Existing Conditions			
	AM PEAK		PM PEAK	
Study Intersections	LOS	DELAY	LOS	DELAY
Gold Dust Avenue and Driveway A (1)				
Eastbound Left	A	83.0	A	7.6
Westbound Left	A	7.9	A	7.5
Northbound Shared Left-Through-Right	B	14.2	B	10.6
Southbound Shared Left-Through-Right	C	17.5	B	12.0
Gold Dust Avenue and Scottsdale Road (2)				
Overall Intersection	D	46.7	D	47.2
Eastbound Left	D	53.9	D	53.4
Eastbound Through	D	47.1	D	48.9
Eastbound Right	D	50.3	D	50.0
Westbound Left	D	53.0	D	54.8
Westbound Through	D	46.7	D	48.8
Westbound Shared Through-Right	D	46.8	D	49.0
Northbound Left	A	6.5	B	18.3
Northbound Through	D	42.4	D	43.2
Northbound Right	C	29.4	C	26.6
Southbound Left	B	15.1	C	22.7
Southbound Through	D	51.0	D	51.9
Southbound Shared Through-Right	E	58.6	E	59.4
Scottsdale Road and Driveway B (3)				
Eastbound Right	B	11.0	B	11.1
Westbound Right	B	10.6	B	11.8
Scottsdale Road and Acacia Driveway (4)				
Eastbound Shared Left-Through-Right	B	13.9	B	13.7
Westbound Shared Left-Through-Right	B	12.7	C	15.4
Northbound Left	A	9.8	B	10.0
Southbound Left	A	9.6	B	10.4

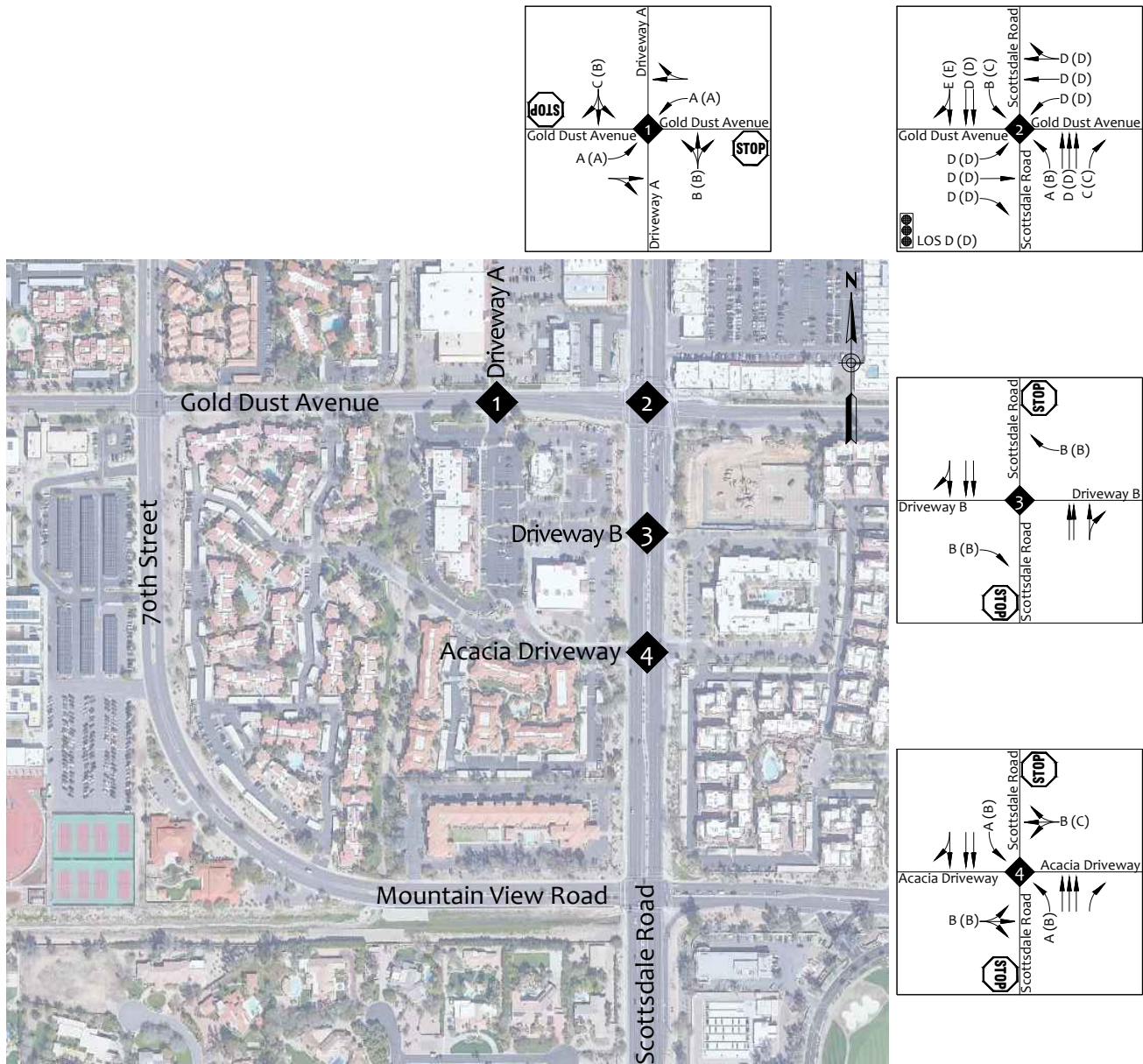

LEGEND

AM (PM) Peak Hour Capacity Analysis

- ◆ Intersection
- ↔ Lane Configuration

FIGURE 5 | EXISTING CAPACITY ANALYSIS



5. PROJECTED TRAFFIC

5.1. TRIP GENERATION

The trip generation for the proposed development was calculated utilizing the Institute of Transportation Engineers (ITE) publication entitled *Trip Generation, 11th Edition*. The ITE rates are based on studies that measured the trip generation characteristics for various types of land uses. The rates are expressed in terms of trips per unit of land use type. This publication is considered to be the standard for the transportation engineering profession.

Proposed Development

The proposed Gold Dust development will be comprised of a total of 212 multifamily residential units that will be located in the three-story buildings. Additionally, an approximate 2,500 square foot fitness/yoga studio will be located on-site that is anticipated to be open to the general public.

The trip generation for the proposed Gold Dust development was calculated utilizing ITE Land Use 220 – Multifamily Housing (Low-Rise) and ITE Land Use 492 – Health Club. However, ITE Land Use 492 does not currently provide weekday data, therefore, ITE Land Use 495 Recreation Community Center weekday data was utilized for the fitness/yoga studio calculations. Trip generation calculations are shown in **Table 4** below. Detailed trip generation calculations are provided in **Appendix G**.

Table 4 – Trip Generation – Proposed Development

Land Use	ITE Code	Qty	Unit	Weekday	AM Peak Hour			PM Peak Hour		
				Total	Total	In	Out	Total	In	Out
Multifamily Housing (Low-Rise)	220	212	Dwelling Units	1,429	85	20	65	108	68	40
Health/Fitness Club	492	2.5	1000 SF GFA	72	3	2	1	9	5	4
Total				1,501	88	22	66	117	73	44

The proposed development is anticipated to generate 1,501 weekday trips with 88 occurring during the AM peak hour and 117 trips during the PM peak hour.

Existing Land Use

According to Maricopa County Assessor, the existing parcel is occupied by 27,581 square-foot commercial building. Utilizing ITE Land Use 822 – Strip Retail Plaza (<40K), the trip generation for the existing land use was calculated as shown in **Table 5** below.



Table 5 – Trip Generation (Existing Land Use)

Land Use	ITE Code	Qty	Unit	Weekday	AM Peak Hour			PM Peak Hour		
				Total	Total	In	Out	Total	In	Out
Strip Retail Plaza (<40k)	822	27,581	1000 SF GLA	1,502	65	40	25	182	91	91

5.2. TRIP GENERATION COMPARISON

Proposed Development versus Existing Land Use

A trip generation comparison between the proposed Gold Dust development and the existing 27,581 square-foot commercial building was calculated. See **Table 6** below.

Table 6 – Trip Generation Comparison

Land Use	ITE Code	Qty	Unit	Weekday	AM Peak Hour			PM Peak Hour		
				Total	Total	In	Out	Total	In	Out
Multifamily Housing (Low-Rise)	220	212	Dwelling Units	1,429	85	20	65	108	68	40
Health/Fitness Club	492	3	1000 SF GFA	72	3	2	1	9	5	4
Proposed Development Total				1,501	88	22	66	117	73	44
Strip Retail Plaza (<40k)	822	27,581	1000 SF GLA	1,502	65	40	25	182	91	91
Existing Land Use Total				1,502	65	40	25	182	91	91
Difference				-1	23	-18	41	-65	-18	-47
Percent Difference				-0.1%	35.2%	-45.0%	163.0%	-35.6%	-19.8%	-51.5%

The build-out of the proposed Gold Dust development is anticipated to generate 1 (0.1%) fewer weekday trips, with 23 (35.2%) more trips during the AM peak hour, and 65 (35.6%) fewer trips during the PM peak hour than the existing 27,581 square-foot commercial building.

5.3. TRIP DISTRIBUTION AND ASSIGNMENT

The trip distribution procedure determines the general pattern of travel for vehicles entering and leaving the proposed development. The trip distribution for Gold Dust development is based on the distribution of the existing traffic. This project is being developed in a primarily developed area, so it can be assumed that the existing trip distribution will remain. The trip distribution is shown in **Figure 6**.

The trip assignment was generally based on proximity of the driveways, permitted turn movements, as well as ease and probability of use. The site generated traffic volumes are shown in **Figure 7**.



LEGEND

AM (PM) Inbound Trip Distribution Percentages

AM (PM) Outbound Trip Distribution Percentages

◆ Intersection

FIGURE 6 | TRIP DISTRIBUTION

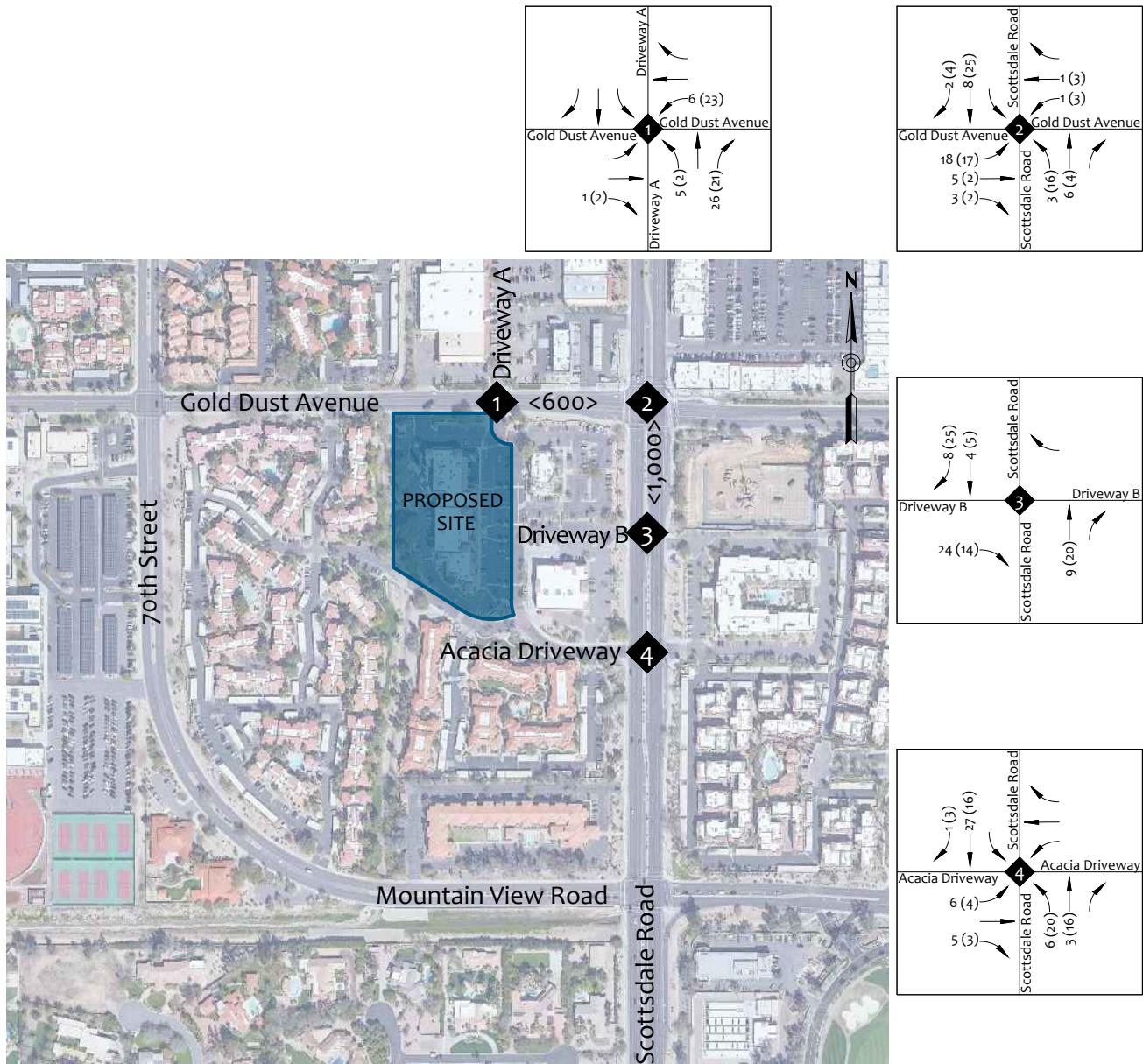

LEGEND

AM (PM) Peak Hour Traffic Volumes

◆ Intersection

<ADT> Average Daily Traffic

FIGURE 7 | SITE TRAFFIC VOLUMES



6. FUTURE CONDITIONS (YEAR 2025)

The proposed Gold Dust development is anticipated to be constructed and ready to open in the year 2025. This section analyzes the effects the proposed development will have on the surrounding roadway network during the opening year of 2025.

6.1. YEAR 2025 NO BUILD TRAFFIC VOLUMES

According to the 2019 Maricopa Associations of Governments (MAG) socioeconomic projections in the City of Scottsdale within the study area (RAZ 247), it is estimated that in the year 2018 the population was approximately 13,549. MAG estimates that the 2030 population of the surrounding area to be 15,420. This results in an approximate annual growth rate of 1.08%.

As a conservative approach, a 2.0% annual growth rate was utilized. See **Appendix H** for the MAG socioeconomic projections. See **Figure 8** for the year 2025 no build traffic volumes.

6.2. YEAR 2025 BUILD TRAFFIC VOLUMES

As previously discussed, the existing 27,581 square foot commercial building will be replaced by the proposed Gold Dust development. Therefore, the trip generation for the land uses that have access to the study driveways (Driveway A, Driveway B, and Acacia Driveway) was calculated.

In addition to the 27,581 square foot commercial building, the following developments currently have access to the site driveways:

- California Pizza Kitchen 5,160 square feet
- CVS Pharmacy 14,391 square feet
- Mosaic Apartments 304 multi-family units
- Verona Condominiums 108 multi-family units



Table 7 – Trip Generation (Adjacent Land Uses)

Land Use	ITE Code	Qty	Unit	Weekday	AM Peak Hour			PM Peak Hour		
				Total	Total	In	Out	Total	In	Out
Multifamily Housing (Low-Rise)	220	304	Dwelling Units	2,024	117	28	89	151	95	56
Multifamily Housing (Low-Rise)	220	108.0	Dwelling Units	768	56	13	43	67	42	25
High-Turnover (Sit-Down) Restaurant	932	5.2	1000 SF GFA	553	49	27	22	47	29	18
Pharmacy/Drugstore with Drive-Thru	881	14.4	1000 SF GFA	1,560	54	28	26	148	74	74
Adjacent Land Use Total Trips				4,905	276	96	180	413	240	173
Strip Retail Plaza (<40k)	822	28	1000 SF GLA	1,502	65	40	25	182	91	91
Commercial Total Trips (To Be Removed)				1,502	65	40	25	182	91	91
Total Trips				6,407	341	136	205	595	331	264
Percent Removed				23%	19%	29%	12%	31%	27%	34%

As shown in **Table 7**, of the parcels with access to the site driveways, the 27,581 square foot commercial building represents 19% and 31% of the total AM and PM peak hour volumes, respectively. Therefore, the 2025 no build traffic volumes entering and exiting the site driveways (Driveway A, Driveway B, and Acacia Driveway) were reduced by the appropriate peak hour percentages. Detailed trip generation calculations are provided in **Appendix G**.

When the site traffic (**Figure 7**) are added to the year 2025 no build traffic (**Figure 8**), the result is the 2025 build traffic volumes. This represents the traffic volumes with the build out of the proposed development. The year 2025 build traffic volumes are shown in **Figure 9**.

6.3. YEAR 2025 NO BUILD CAPACITY ANALYSIS

The capacity and level of service for the study area intersections were evaluated for the 2025 no build scenario. The PHF was assumed to be 0.92.

The year 2025 no build AM and PM peak hour level of service and delay for the study intersections are shown in **Table 8**. The detailed capacity analysis sheets can be found in **Appendix I**.

The results of the year 2025 no build capacity analysis are shown in **Figure 10**. The results of the capacity analysis reveal the following locations with a level of service (LOS) E or F:

Gold Dust Avenue and Scottsdale Road (2)

- Southbound shared through-right AM and PM peak hours operate at LOS E



6.4. YEAR 2025 BUILD CAPACITY ANALYSIS

The capacity and level of service for the study area intersections were evaluated for the year 2025 build traffic volumes. See **Figure 9**. The PHF was assumed to be 0.92.

The year 2025 build AM and PM peak hour level of service and delay for the study intersections are shown in **Table 8**. The detailed capacity analysis sheets can be found in **Appendix J**.

The results of the year 2025 build capacity analysis are shown in **Figure 11**. All movements operate at a LOS D or better or are maintained at the year 2025 no build level of service.



Table 8 – Year 2025 Level of Service and Delay

Intersection	2025 No Build Conditions				2025 Build Conditions			
	AM PEAK		PM PEAK		AM PEAK		PM PEAK	
Study Intersections	LOS	DELAY	LOS	DELAY	LOS	DELAY	LOS	DELAY
Gold Dust Avenue and Driveway A (1)								
Eastbound Left	A	7.7	A	7.6	A	7.7	A	7.6
Westbound Left	A	7.6	A	7.5	A	7.6	A	7.5
Northbound Shared Left-Through-Right	B	10.6	B	10.5	B	10.3	B	10.2
Southbound Shared Left-Through-Right	B	11.5	B	11.7	B	11.8	B	12.3
Gold Dust Avenue and Scottsdale Road (2)								
Overall Intersection	D	47.1	D	45.7	D	46.7	D	45.4
Eastbound Left	D	54.2	D	53.2	D	53.2	D	54.1
Eastbound Through	D	47.5	D	48.2	D	45.7	D	48.0
Eastbound Right	D	51.2	D	49.3	D	48.4	D	49.1
Westbound Left	D	53.3	D	54.5	D	51.5	D	54.5
Westbound Through	D	47.0	D	48.1	D	45.2	D	47.9
Westbound Shared Through-Right	D	47.2	D	48.4	D	45.3	D	48.2
Northbound Left	A	5.8	C	20.2	A	7.4	C	20.9
Northbound Through	D	42.9	D	41.4	D	42.7	D	41.3
Northbound Right	C	29.9	C	24.7	C	29.7	C	24.7
Southbound Left	B	14.7	C	25.1	B	15.8	C	25.4
Southbound Through	D	51.4	D	50.3	D	51.2	D	49.7
Southbound Shared Through-Right	E	59.1	E	57.5	E	58.9	E	56.9
Scottsdale Road and Driveway B (3)								
Eastbound Right	B	11.0	B	11.3	B	11.2	B	11.4
Westbound Right	B	10.6	B	12.4	B	10.6	B	12.4
Scottsdale Road and Acacia Driveway (4)								
Eastbound Shared Left-Through-Right	B	14.4	C	16.8	C	16.2	C	18.4
Westbound Shared Left-Through-Right	B	13.0	C	21.5	B	13.2	C	19.4
Northbound Left	A	10.0	B	10.3	B	10.0	B	10.5
Southbound Left	A	9.4	B	10.7	A	9.4	B	11.0

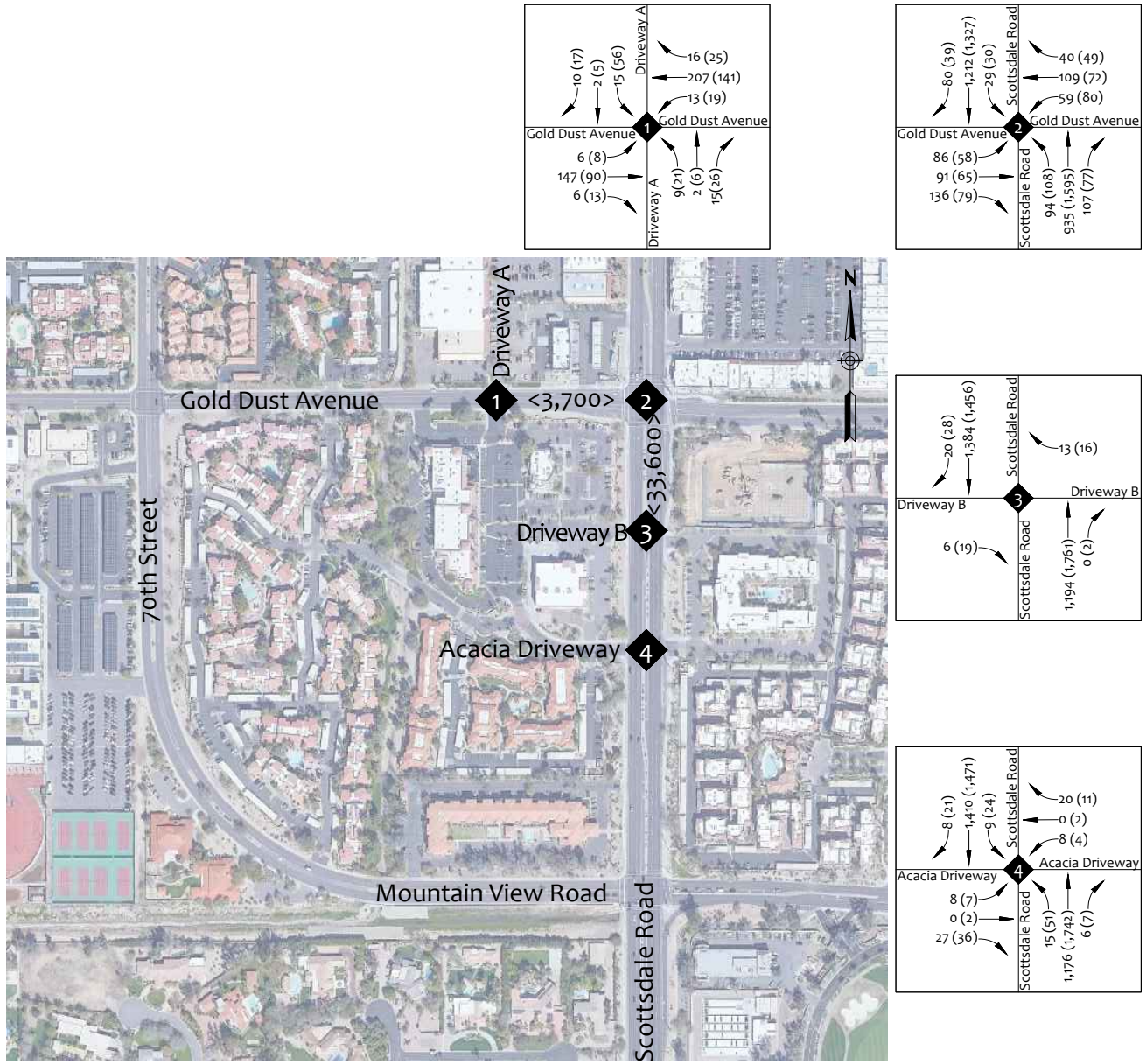

LEGEND

AM (PM) Peak Hour Traffic Volumes

◆ Intersection

<ADT> Average Daily Traffic

FIGURE 8 | YEAR 2025 NO BUILD TRAFFIC VOLUMES

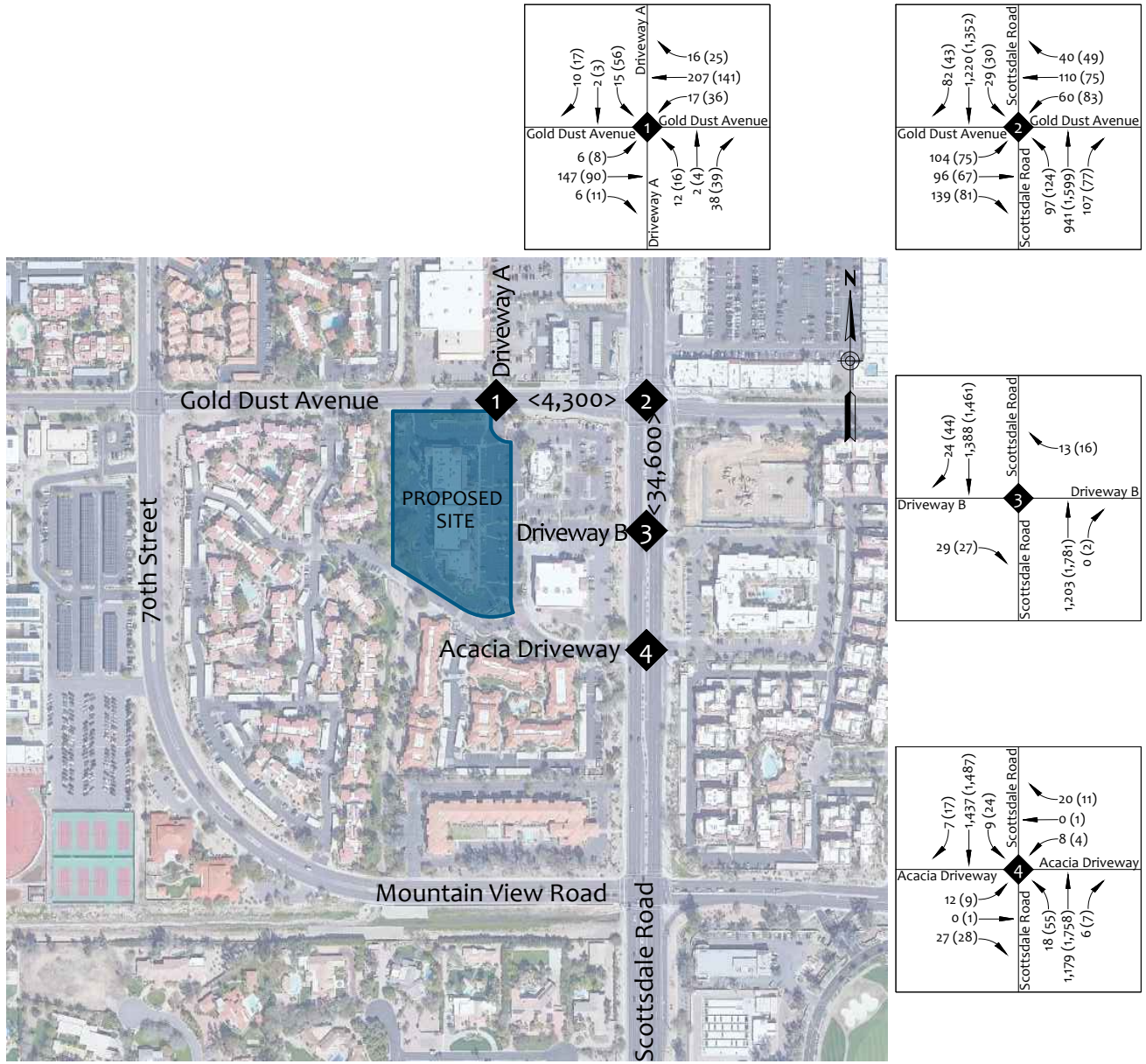
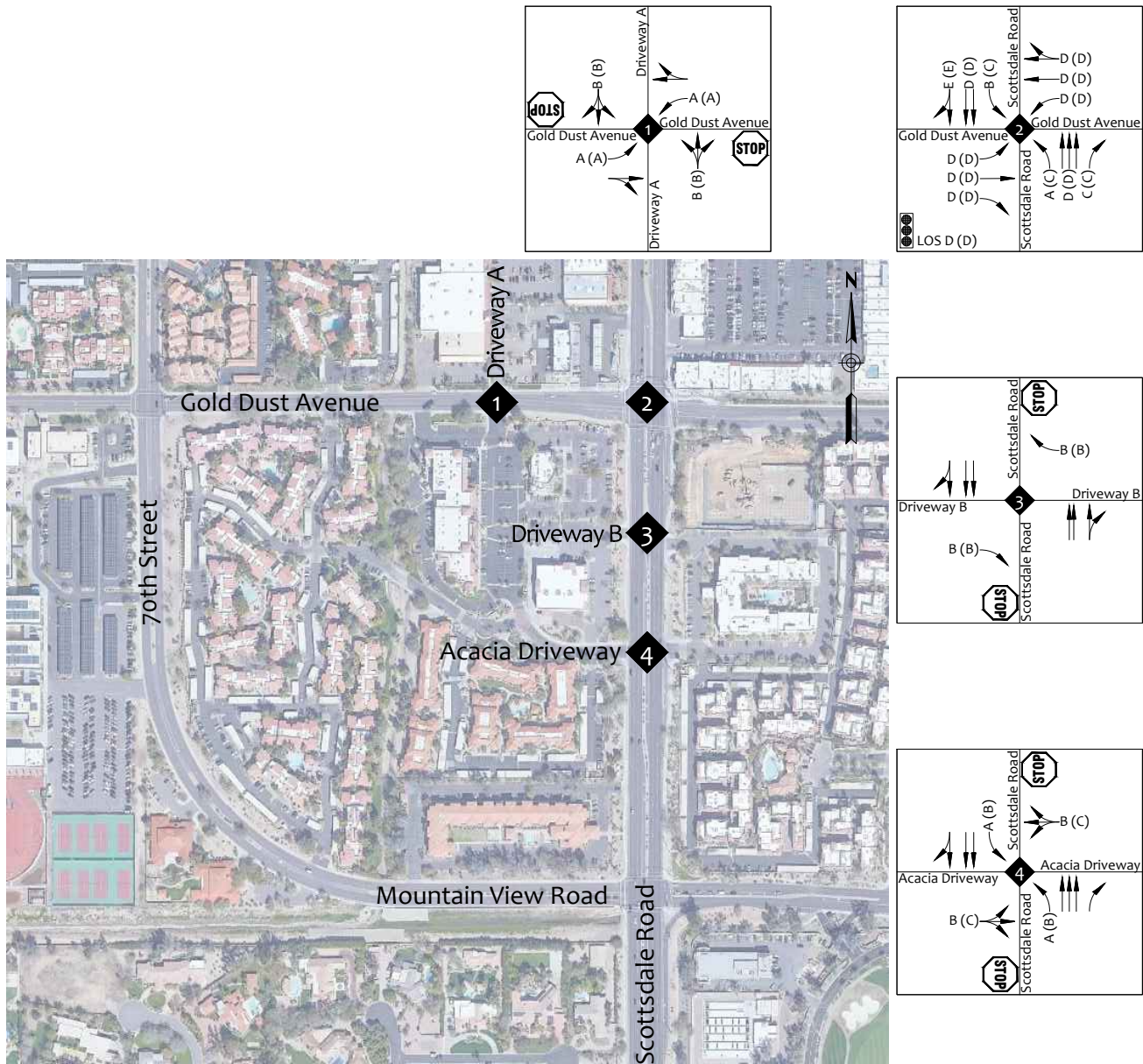

FIGURE 9 | YEAR 2025 BUILD TRAFFIC VOLUMES



LEGEND

AM (PM) Peak Hour Capacity Analysis



-  Intersection
-  Lane Configuration

FIGURE 10 | YEAR 2025 NO BUILD CAPACITY ANALYSIS



- LEGEND**
- AM (PM) Peak Hour Capacity Analysis
 - ◆ Intersection
 - ↔ Lane Configuration

FIGURE 11 | YEAR 2025 BUILD CAPACITY ANALYSIS

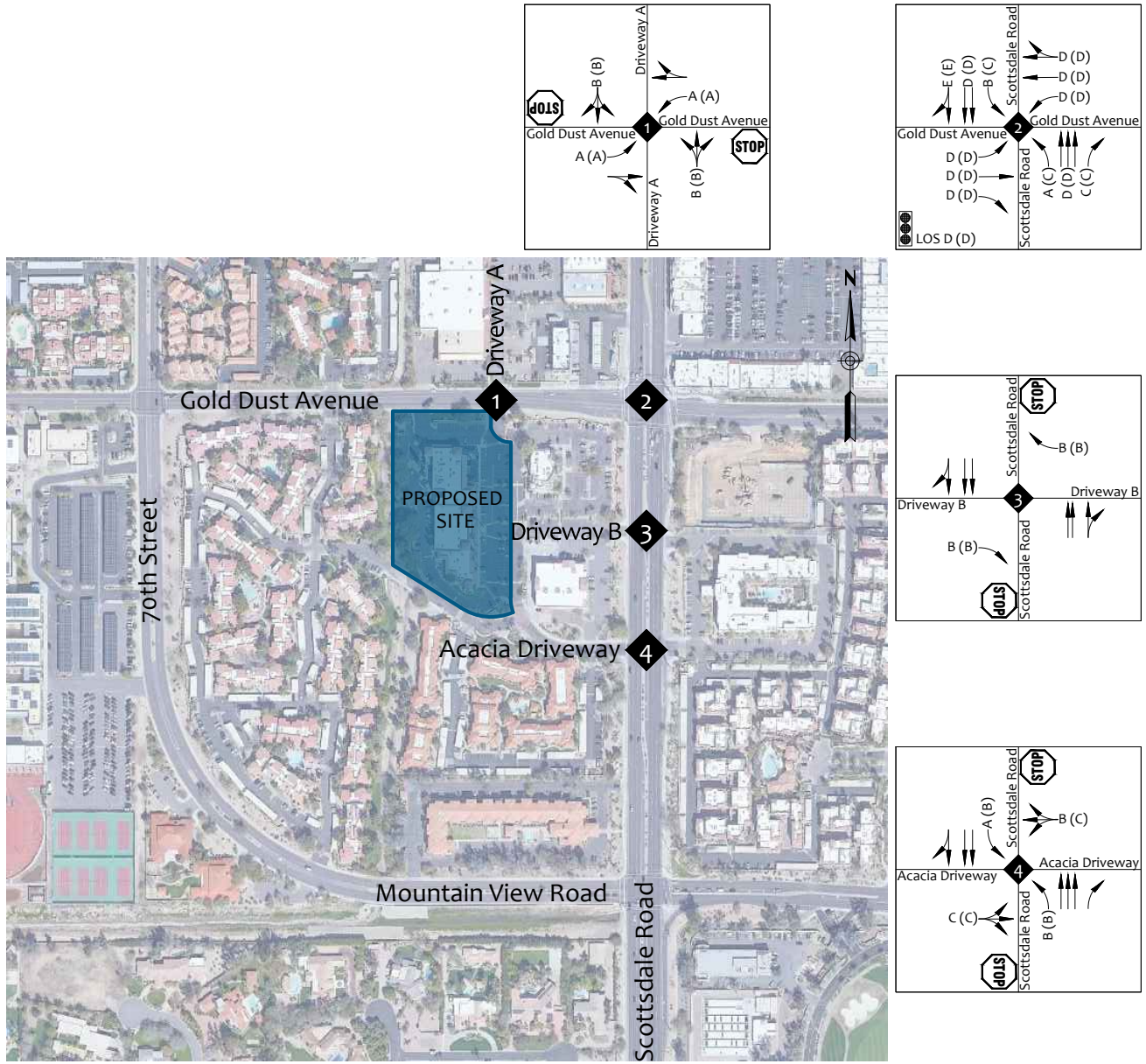

7. TURN LANE ANALYSIS

7.1. RIGHT TURN LANE WARRANT

The City of Scottsdale 2018 *Design Standards & Policies Manual* Section 5.3.206 deceleration lane criteria is analyzed below for the site driveways.

Deceleration lanes are required at all new driveways on major arterials and at new commercial/retail driveways on minor arterials. To determine the need for a deceleration lane on streets classified as a minor arterial or collector, the following Scottsdale criteria is used:

- At least 5,000 vehicle per day are expected to be using the street.
- The roadway’s 85th percentile speed limit is at least 35 mph.
- At least 30 vehicles will make right-turns into the driveway during a 1-hour period.

The site driveways were evaluated using the City of Scottsdale deceleration lane criteria. See **Table 9**.

Table 9 –Right Turn Lane Criteria Analysis

Year	Scenario	On	At	No. Thru Lanes	Speed Limit	ADT	Peak Hour	Right Turn		
								Direction	Right	Warranted
2025	Build	Gold Dust Avenue	Driveway A	1	30	4,300	AM	EB	6	NO
							PM		11	
2025	Build	Scottsdale Road	Driveway B	3	40	34,600	AM	SB	24	YES
							PM		44	
2025	Build	Scottsdale Road	Driveway C	3	40	34,600	AM	SB	7	NO
							PM		17	

A southbound right turn deceleration lane at Scottsdale Road and Driveway B (3) meets the City of Scottsdale criteria that triggers consideration for installation. Several factors to consider along with these criteria are discussed below:

- Driveway B is an existing driveway that serves the existing commercial development. At the time of the traffic count data collection effort, the commercial development was not operating at full capacity with full occupancy and activity. Based on the trip generation calculations, as shown in **Table 6**, the existing commercial development when it was operating at full capacity was likely generating similar traffic levels as the proposed Gold Dust development. Based on the trip generation comparison the proposed develop in fact generates less traffic. This driveway has operated with no historical concerns and is anticipated to operate similar with the new development.



- Right turn deceleration lanes are often installed in high traffic, higher speed areas where the primary roadway function is to allow through traffic to progress along the roadway as efficiently as possible and without having to slow for right turning vehicles. This stretch of Scottsdale Road has a posted speed limit of 40 mph encouraging slower speed than a typical arterial roadway. Additionally, along this stretch of road, the majority of driveway do not have a right turn deceleration lane. Including driveways of land uses that are much higher traffic generators.
- According to the crash analysis in [Section 3.6](#), there were no major crashes or crash pattern identified with the traffic operations along this stretch of roadway, nor at the existing driveways to the existing development.

Therefore, considering the character of the surrounding area, the existing infrastructure and standards historically established, existing and historic traffic operations, a proposed land use that is consistent with the area, and the desire to maintain the character and consistency of the area, a right turn deceleration lane is not recommended for installation at the intersection of Scottsdale Road and Driveway B (3).



7.2. QUEUE ANALYSIS

Queue calculations were completed for the turn lanes within the study intersections based on the year 2025 build traffic volumes. The maximum 95th percentile queue calculated by Synchro, Version 11 for the study intersections is shown in **Table 10** below.

Table 10 – Queue Analysis

Intersection	Movement	Existing	HCM 95th Percentile
Gold Dust Avenue and Driveway A (1)	NB Shared Left-Through-Right	On-Site	25'
	SB Shared Left-Through-Right	On-Site	25'
	EB Left	TWLTL	0'
	WB Left	TWLTL	25'
Scottsdale Road and Gold Dust Avenue (2)	NB Left	140'	75'
	NB Right	160'	50'
	SB Left	155'	25'
	EB Left	100'	150'
	EB Right	50'	75'
	WB Left	100'	125'
Scottsdale Road and Driveway B (3)	EB Right	On-Site	25'
	WB Right	On-Site	25'
Scottsdale Road and Acacia Driveway (4)	NB Left	140'	25'
	SB Left	140'	0'
	EB Shared Left-Through-Right	On-Site	25'
	WB Shared Left-Through-Right	On-Site	25'

The northbound approach at the intersection of Gold Dust Avenue and Driveway A (1) has a 95th percentile queue of one (1) vehicle.

Similarly, the westbound approach at the intersection of Gold Dust Avenue and Driveway A (1) has a 95th percentile queue of one (1) vehicle. The eastbound left at the intersection of Scottsdale Road and Gold Dust Avenue has a 95th percentile queue of 150-feet, or six (6) vehicles. With approximately 300-feet between Driveway A and Scottsdale Road, sufficient room is provided for the back-to-back left turn lanes.



8. GOLD DUST ACCESS

Driveway A is an existing driveway located along Gold Dust Avenue, approximately 400 feet west of Scottsdale Road (centerline to centerline) and is slightly offset with the existing driveway that is located on the north side of Gold Dust Avenue. As shown on the proposed site plan Driveway A curves into the parking lot on-site, where it intersects with an internal drive aisle.

With the build out of the proposed Gold Dust development, this existing access will be slightly modified to align directly with the north driveway. Aligning driveways is generally a good practice and recommended roadway configuration.

The City of Scottsdale has requested Driveway A be shifted approximately 50-feet to the east to align with the internal drive aisle. See [Figure 12](#). This request was evaluated, below are some key points to note with moving the access to the east:

- Aligning driveways is generally a good practice and recommended roadway configuration.
- The misalignment of driveways creates conflicting left turn movements. Shifting the driveway east, the northbound lefts entering the two-way left turn lane would conflict with the southbound lefts.
- There are back-to-back lefts with the westbound left turns at the driveway and the eastbound left turns at the signalized intersection at Scottsdale Road. As proposed, there is 300-feet provided for the back-to-back lefts. As described in the prior section, 150-feet is the anticipated 95th percentile queue for the eastbound left turning movement at Scottsdale Road, and 25-feet for the westbound left turning movement at the driveway for a total of 175-feet. This results in 125-feet of separation between the two anticipated queues. Shifting the proposed driveway east by approximately 50-feet reduces this to 75-feet. Ideally greater distance and separation is desirable.
- As indicated in [Section 7.2](#), the northbound approach at the intersection of Gold Dust Avenue and Driveway A (1) experiences a 95th percentile queue of one (1) vehicle. Approximately 40 feet is provided between the face of curb on Gold Dust Avenue and the point of curvature of the drive aisle. This provided sufficient space for the 95th percentile queuing without any major impact to on-site circulation.

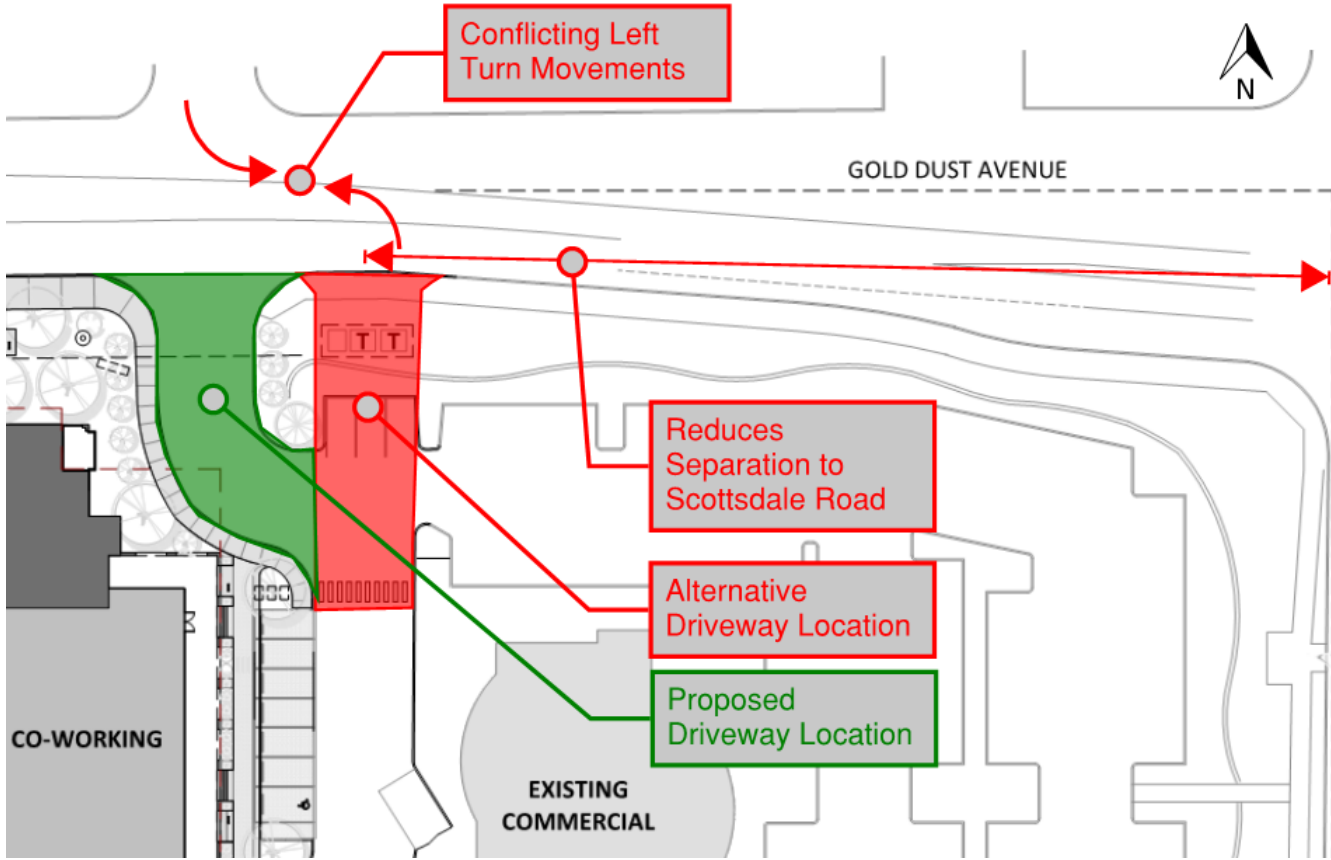

Figure 12 – Gold Dust Access



9. RECOMMENDATIONS & CONCLUSIONS

The proposed Gold Dust development will be located on the southwest corner of Gold Dust Avenue and Scottsdale Road in the City of Scottsdale, Arizona. The proposed Gold Dust development will be comprised of a total of 212 multifamily residential units, of which, there will be 159 one-bedroom, 51 two-bedroom, and 2 three-bedrooms units. Additionally, an approximate 2,500 square foot fitness/yoga studio will be located on-site that will be open to the general public.

Trip Generation

The proposed development is anticipated to generate 1,501 weekday trips with 88 occurring during the AM peak hour and 117 trips during the PM peak hour.

Trip Generation Comparison

The build-out of the proposed Gold Dust development is anticipated to generate 1 (0.1%) fewer weekday trips, with 23 (35.2%) more trips during the AM peak hour, and 65 (35.6%) fewer trips during the PM peak hour than the existing 27,581 square-foot commercial building.

Recommendations

The existing Driveway A located approximately 400 feet west of Scottsdale Road will be slightly modified to align with the driveway on the north side of Gold Dust Avenue. Aligned driveways are ideal as they minimize confusion and overlapping of vehicular paths, specifically left turn movements. This driveway will continue to operate as it does today as a full access driveway.

Additionally, an existing full access driveway located along Gold Dust Avenue, approximately 600 feet west of Scottsdale Road will be removed. This will reduce the number of conflict points along this stretch of roadway.

It is anticipated that the proposed Gold Dust development will operate at acceptable levels of service and the access modifications described above will improve the overall operation of Gold Dust Avenue in this area.



Appendix A – Proposed Site Plan



500 Washington Avenue South, Suite 1088
Minneapolis, MN 55415
p 612.339.5508 | f 612.339.5382
www.esgarth.com



11/2/2022 10:11:06 AM



Appendix B – Collision History

CITY OF SCOTTSDALE

COLLISION SUMMARY

REPORT #	DATE YYMMDD	TIME HHMM	NORTH / SOUTH ST.	TYPE	EAST WEST ST.	TYPE	DIR FROM	DIST FROM	INJ. SEV. #1 #2	PHYS. COND. #1 #2	VIOLATION #1 #2	ACTION #1 #2	TRAV. DIR. #1 #2	MANNER OF COLLISION	COMMENTS
2004098	200224	1326	70	ST	GOLD DUST	AV	S			0 0	20 1	4 1	NE SB	2	
2100364	210106	1343	70	ST	GOLD DUST	AV	AT			0 0	6 1	1 1	WB NB	2	
2103655	210222	1503	70	ST	GOLD DUST	AV	AT			5 1	6 1	1 1	WB SB	2	
2107198	210414	1145	70	ST	GOLD DUST	AV	S	726		0 0	20 1	4 1	NB NB	7	
2115335	210806	0735	70	ST	GOLD DUST	AV	S	148		0 0	20 1	4 1	SB SB	2	
2112793	210630	2040	SCOTTSDALE	RD	ACACIA	DR	S	44		0 0	12 1	8 1	NB NB	6	
1900172	190103	1725	SCOTTSDALE	RD	GOLD DUST	AV	AT		1 1	0 0		1 3	NB NB	4	MULTI VEH 3
1900250	190104	2231	SCOTTSDALE	RD	GOLD DUST	AV	W	346	1 1	97 0	20 1	4 1	NB EB	2	
1902451	190201	1433	SCOTTSDALE	RD	GOLD DUST	AV	AT			0 0	20 1	4 3	NB EB	3	
1902913	190206	1149	SCOTTSDALE	RD	GOLD DUST	AV	S	25		0 0	4 1	1 3	NB NB	4	
1903511	190214	1622	SCOTTSDALE	RD	GOLD DUST	AV	AT			0 0	1 1	1 1	NB NB	4	
1912857	190616	1504	SCOTTSDALE	RD	GOLD DUST	AV	S	200		99 0	2 1	1 1	SB SB	4	
1913770	190628	1500	SCOTTSDALE	RD	GOLD DUST	AV	AT			0 0	97 1	1 3	EB EB	4	
1914574	190710	1319	SCOTTSDALE	RD	GOLD DUST	AV	AT			0 0	20 1	4 1	WB SB	3	
1916291	190803	1803	SCOTTSDALE	RD	GOLD DUST	AV	N	250		99 0	13 1	1 1	SB SB	6	
1919823	190921	1435	SCOTTSDALE	RD	GOLD DUST	AV	AT			0 0	6 1	1 1	NB WB	2	
1920175	190926	0316	SCOTTSDALE	RD	GOLD DUST	AV	S	500		0 0	20 1	4 1	SB SB	6	
1920362	190928	1139	SCOTTSDALE	RD	GOLD DUST	AV	N	115		99 0	99 1	8 1	SB SB	6	
1921138	191009	1856	SCOTTSDALE	RD	GOLD DUST	AV	AT			4 0	2 1	5 3	EB WB	5	
1923485	191109	1804	SCOTTSDALE	RD	GOLD DUST	AV	AT			0 0	12 1	8 1	NB NB	6	
1925155	191204	1218	SCOTTSDALE	RD	GOLD DUST	AV	AT			0 0	20 1	4 1	EB EB	6	
1925570	191209	1453	SCOTTSDALE	RD	GOLD DUST	AV	AT			0 0	1 1	4 1	WB SB	2	
2001066	200115	1240	SCOTTSDALE	RD	GOLD DUST	AV	W	150		0 0	7 1	6 1	WB WB	2	
2004960	200306	1743	SCOTTSDALE	RD	GOLD DUST	AV	AT			1 0	1 1	1 3	NB NB	4	
2009548	200602	1200	SCOTTSDALE	RD	GOLD DUST	AV	AT			0 0	20 1	4 1	NW SB	3	
2009827	200608	0558	SCOTTSDALE	RD	GOLD DUST	AV	AT			0 0	20 1	4 1	NW SB	3	
2010483	200618	1414	SCOTTSDALE	RD	GOLD DUST	AV	AT			0 0	6 1	1 1	NB WB	2	
2012488	200724	1223	SCOTTSDALE	RD	GOLD DUST	AV	S	570		0 0	20 1	4 1	SB SB	4	
2014410	200826	1736	SCOTTSDALE	RD	GOLD DUST		AT			99 99	99 99	14 99	EB 99	99	
2015360	200910	2235	SCOTTSDALE	RD	GOLD DUST		W	400		0 0	2 1	1 1	NB WB	2	
2016146	200924	0007	SCOTTSDALE	RD	GOLD DUST	AV	W	550		99	2 0	1	EB	1	
2021166	201209	0835	SCOTTSDALE	RD	GOLD DUST	AV	AT			0 0	6 1	1 1	NB EB	2	
2021471	201213	0943	SCOTTSDALE	RD	GOLD DUST	AV	S	570		99 0	2 1	1 2	SB SB	4	
2021991	201220	1301	SCOTTSDALE	RD	GOLD DUST	AV	AT			0 0	99 99	4 1	NB SB	3	
2102668	210208	1405	SCOTTSDALE	RD	GOLD DUST	AV	AT			99 0	99 20	1 4	WB EB	3	
2104564	210307	1655	SCOTTSDALE	RD	GOLD DUST	AV	AT			0 0	6 1	1 1	SB WB	2	

REPORT #	DATE YYMMDD	TIME HHMM	NORTH / SOUTH ST.	TYPE	EAST WEST ST.	TYPE	DIR FROM	DIST FROM	INJ. SEV. #1 #2	PHYS. COND. #1 #2	VIOLATION #1 #2	ACTION #1 #2	TRAV. DIR. #1 #2	MANNER OF COLLISION	COMMENTS
2106185	210330	1507	SCOTTSDALE	RD	GOLD DUST	AV	AT			0 0	20 1	4 1	WB SB	3	
2106234	210331	1241	SCOTTSDALE	RD	GOLD DUST	AV	AT			0 0	20 1	4 1	NW SB	2	
2108802	210505	1616	SCOTTSDALE	RD	GOLD DUST	AV				0 0	12 1	8 1	SB SB	6	
2114335	210722	1709	SCOTTSDALE	RD	GOLD DUST	AV				0 0	97 1	1 3	NB NB	6	
2116247	210819	1707	SCOTTSDALE	RD	GOLD DUST	AV	S	315		0 0	20 1	97 1	EB SB	2	
2120524	211020	2042	SCOTTSDALE	RD	GOLD DUST					0 0	20 1	4 1	WB SB	3	
2121788	211107	0000	SCOTTSDALE	RD	GOLD DUST	AV				0 0	20 1	1 1	SB EB	2	
2123040	211124	1942	SCOTTSDALE	RD	GOLD DUST	AV	W	95		0 0	20 1	4 1	EB EB	2	
1900744	190111	0652	SCOTTSDALE	RD	MOUNTAIN VIEW	RD	W	552		0 0	4 1	2 5	WB WB	4	
1901008	190114	1517	SCOTTSDALE	RD	MOUNTAIN VIEW	RD	AT			0 0	13 1	1 1	NB NB	6	
1902553	190202	1223	SCOTTSDALE	RD	MOUNTAIN VIEW	DR	N	100		0 0	2 1	1 3	SB SB	4	
1902555	190202	1235	SCOTTSDALE	RD	MOUNTAIN VIEW	RD	N	150		0 0	97 1	1 3	SB SB	4	
1903773	190217	1751	SCOTTSDALE	RD	MOUNTAIN VIEW	RD	AT			0 0	20 1	4 1	SB NB	3	
1903979	190220	1139	SCOTTSDALE	RD	MOUNTAIN VIEW	RD	AT			0 0	6 1	1 1	NB WB	2	
1905688	190314	1908	SCOTTSDALE	RD	MOUNTAIN VIEW	RD	W	141		0 0	14 1	17 1	NB WB	5	
1908400	190418	1747	SCOTTSDALE	RD	MOUNTAIN VIEW	RD	S	300		0 0	7 1	4 1	NB NB	2	
1908949	190425	1245	SCOTTSDALE	RD	MOUNTAIN VIEW	RD	S	40		99 0	4 1	1 3	NB NB	4	
1909048	190426	1656	SCOTTSDALE	RD	MOUNTAIN VIEW	RD	AT			0 0	20 1	4 1	EB NB	3	
1910713	190518	1927	SCOTTSDALE	RD	MOUNTAIN VIEW	RD	AT			0	7 0	6	SB	1	
1911216	190525	1150	SCOTTSDALE	RD	MOUNTAIN VIEW	RD	AT			0 0	20 1	4 1	SB NB	2	
1913513	190625	1202	SCOTTSDALE	RD	MOUNTAIN VIEW	RD	W	100		0 0	2 1	3 3	EB EB	4	
1917704	190823	2030	SCOTTSDALE	RD	MOUNTAIN VIEW	RD	W	549		0 0	2 1	1 5	WB NB	4	
1924177	191119	1403	SCOTTSDALE	RD	MOUNTAIN VIEW	RD	AT			0 0	1 1	1 3	SB SB	6	
1926220	191218	1400	SCOTTSDALE	RD	MOUNTAIN VIEW	RD	AT			0 0	3 1	5 5	NB NB	4	
1926376	191220	1203	SCOTTSDALE	RD	MOUNTAIN VIEW	RD	AT			0 0	20 1	4 1	EB NB	2	
1926445	191221	1233	SCOTTSDALE	RD	MOUNTAIN VIEW	RD	AT			0 0	6 1	1 1	WB NB	2	
200032	200105	1349	SCOTTSDALE	RD	MOUNTAIN VIEW	RD	AT			0 0	12 12	8 8	NB NB	6	
2001435	200120	0841	SCOTTSDALE	RD	MOUNTAIN VIEW	RD	AT			0 0	3 1	5 3	NB NB	4	
2003384	200214	2056	SCOTTSDALE	RD	MOUNTAIN VIEW	RD	AT			0 0	7 1	5 1	SB SB	2	
2004711	200303	1334	SCOTTSDALE	RD	MOUNTAIN VIEW	RD	N	310		0 0	12 1	8 1	NB NB	6	
2005676	200316	1206	SCOTTSDALE	RD	MOUNTAIN VIEW	RD	N	748		0 0	13 1	8 1	NB NB	6	
2009926	200609	1244	SCOTTSDALE	RD	MOUNTAIN VIEW	RD	S	50		0 0	2 1	2 3	SB SB	4	
2011738	200710	1815	SCOTTSDALE	RD	MOUNTAIN VIEW	RD	AT			0 0	20 1	4 1	SB NB	3	
2011909	200714	0610	SCOTTSDALE	RD	MOUNTAIN VIEW	RD	N	15		0	3 0	1	NB	1	
2012436	200723	1405	SCOTTSDALE	RD	MOUNTAIN VIEW	RD	N	40		0 0	2 1	2 3	NB NB	4	
2012731	200729	0747	SCOTTSDALE	RD	MOUNTAIN VIEW	RD	AT			0 0	6 1	1 1	SB EB	3	
2016566	200930	0730	SCOTTSDALE	RD	MOUNTAIN VIEW	RD	N	30		0 0	4 1	1 1	SB SB	4	
2016590	200930	1338	SCOTTSDALE	RD	MOUNTAIN VIEW	RD	AT			0 0	2 1	1 3	SB SB	4	

REPORT #	DATE YYMMDD	TIME HHMM	NORTH / SOUTH ST.	TYPE	EAST WEST ST.	TYPE	DIR FROM	DIST FROM	INJ. SEV. #1 #2	PHYS. COND. #1 #2	VIOLATION #1 #2	ACTION #1 #2	TRAV. DIR. #1 #2	MANNER OF COLLISION	COMMENTS
2018926	201104	1827	SCOTTSDALE	RD	MOUNTAIN VIEW	RD	AT			0 0	99 1	4 4	WB WB	4	
2021152	201208	2227	SCOTTSDALE	RD	MOUNTAIN VIEW	RD	AT			0 0	1 1	1 4	NB SE	3	
2100546	210108	1929	SCOTTSDALE	RD	MOUNTAIN VIEW	RD	N	320		0 0	2 1	1 1	SB NB	97	
2101624	210125	0544	SCOTTSDALE	RD	MOUNTAIN VIEW	RD	AT			0 0	2 97	1 4	NB SB	5	
2103585	210221	1732	SCOTTSDALE	RD	MOUNTAIN VIEW	RD	AT			0 0	2 1	1 3	NB NB	4	
2105777	210324	1854	SCOTTSDALE	RD	MOUNTAIN VIEW	RD	AT			99 0	20 1	6 1	SB EB	2	
2107617	210420	0728	SCOTTSDALE	RD	MOUNTAIN VIEW	RD	N			0 0	7 1	5 1	SW SB	6	BIKE
2111254	210608	1045	SCOTTSDALE	RD	MOUNTAIN VIEW	RD	W	87		0 0	12 1	8 1	EB EB	2	
2112741	210630	0905	SCOTTSDALE	RD	MOUNTAIN VIEW	RD				0 0	7 1	6 1	SW EB	97	
2113118	210706	0818	SCOTTSDALE	RD	MOUNTAIN VIEW	RD	S	0		99	97	1	NB	1	
2120508	211020	1625	SCOTTSDALE	RD	MOUNTAIN VIEW	DR				0 0	20 1	5 1	SB SB	2	
2120573	211021	1557	SCOTTSDALE	RD	MOUNTAIN VIEW					0 0	20 1	4 1	WB SB	3	
2122530	211117	0928	SCOTTSDALE	RD	MOUNTAIN VIEW	RD	E	50		3 0	4 1	2 3	WB WB	4	
2123385	211130	1116	SCOTTSDALE	RD	MOUNTAIN VIEW	RD				0 0	2 1	4 3	NW NW	4	
2124767	211218	1351	SCOTTSDALE	RD	MOUNTAIN VIEW	RD	N	100		0 0	2 1	1 1	SB SB	4	

KEY

INJURY SEVERITY:

1=NO INJURY, 2=POSSIBLE INJURY, 3=NON-INCAPACITATING INJURY, 4=INCAPACITATING INJURY, 5=FATAL INJURY, 99=NOT REPORTED / UNKNOWN

PHYSICAL CONDITION:

0=NO APPARENT INFLUENCE, 1=ILLNESS, 2=PHYSICAL IMPAIRMENT, 3=FELL ASLEEP / FATIGUED 4=ALCOHOL, 5=DRUGS, 6=MEDICATIONS, A=NO TEST GIVEN, B=TEST GIVEN, C=TEST REFUSED, D=TESTING UNKNOWN, 97=OTHER, 99=UNKNOWN

VIOLATION:

1=NO IMPROPER ACTION, 2=SPEED TOO FAST FOR CONDITIONS, 3=EXCEEDED LAWFUL SPEED 4=FOLLOWED TOO CLOSELY. 5=RAN STOP SIGN, 6=DISREGARDED TRAFFIC SIGNAL7=MADE IMPROPER TURN, 8=DROVE/RODE IN OPPOSING TRAFFIC LANE, 9=KNOWINGLY OPERATED WITH FAULTY / MISSING EQUIPMENT, 10=REQUIRED MOTORCYCLE SAFETY EQUIPMENT NOT USED, 11=PASSED IN NO PASSING ZONE, 12=UNSAFE LANE CHANGE, 13=FAILED TO KEEP IN PROPER LANE, 14=DISREGARDED PAVEMENT MARKINGS, 15=OTHER UNSAFE PASSING, 16=INATTENTION/DISTRACTION, 17=DID NOT USE CROSSWALK, 18=WALKED ON WRONG SIDE OF ROAD, 19=ELECTRONIC COMMUNICATIONS DEVICE, 20=FAILED TO YIELD RIGHT OF WAY (added August 2014), 97=OTHER, 99 UNKNOWN

ACTION:

1=GOING STRAIGHT AHEAD, 2=SLOWING IN TRAFFICWAY, 3=STOPPED IN TRAFFICWAY, 4=MAKING LEFT TURN, 5=MAKING RIGHT TURN, 6=MAKING U-TURN, 7=OVERTAKING/PASSING, 8=CHANGING LANES, 9=NEGOTIATING A CURVE, 10=BACKING, 11=AVOIDING VEH/OBJ/PED/CYCLIST/ANIMAL, 12=ENTERING PARKING POSITION, 13=LEAVING PARKING POSITION, 14=PROPERLY PARKED, 15=IMPROPERLY PARKED, 16=DRIVERLESS MOVING VEHICLE, 17=CROSSING ROAD, 18=WALKING WITH TRAFFIC, 19=WALKING AGAINST TRAFFIC, 20=STANDING, 21=LYING, 22=GETTING ON OR OFF VEHICLE, 23=WORKING ON/PUSHING VEHICLE, 24=WORKING ON ROAD, 97=OTHER, 99=UNKNOWN

MANNER OF COLLISION:

1=SINGLE VEHICLE, 2=ANGLE (front to side, other than left turn), 3=LEFT TURN, 4=REAR END (front to rear), 5=HEAD-ON (front to front, other than left turn), 6=SIDESWIPE (same direction), 7=SIDESWIPE (opposite direction), 8=REAR-TO-SIDE, 9=REAR TO REAR, 97=OTHER, 99=UNKNOWN

TOTAL 89



Appendix C – Parcel Information

175-56-002H

Commercial Parcel

This is a Commercial parcel located at [10050 N SCOTTSDALE RD PARADISE VALLEY 85253](#). The current owner is ACACIA CREEK PARTNERS LLC. Its current year full cash value is \$7,970,400.

MAPS	PICTOMETRY	VIEW/PAY TAX BILL	DEED
OWNER	VALUATIONS	ADDITIONAL INFO	SKETCHES
MAP FERRET	SIMILAR PARCELS	REGISTER RENTAL	

PROPERTY INFORMATION



[10050 N SCOTTSDALE RD PARADISE VALLEY 85253](#)

MCR #

Description

PT NE4 SEC 27 DAF COM SE COR SD NE4 TH N 646.85F W 65F TO POB TH CONT W 128F TO BEG OF 165F RAD CUR TO RT TH NWLY ALG SD CUR 216.76F TH S 75D 16M W 20F TO BEG OF NON-TAN CUR TH WLY ALG ARC SD CUR TO R T 10F TH S 12D 40M E 15F TO BEG OF NON-TAN CUR TH WLY ALG ARC SD CUR TO RT 103.07F TH N 57D 08M W 250.76F N 376.03F TO A PT ON SLY R/W LN OF GOLD DUST RD TH E ALG SD R/W LN 360.68F S 464.70F TO BEG OF 135F RAD CUR TO LFT TH SLY ALG SD CUR 34.71F TH N 75D 16M E 5.50F TO BEG OF NON-TAN CUR TH SELY ALG ARC OF SD CUR TO LFT 170.12F TH E 14.87F TH N 87D 08M E 75.23F N 22.53F E 38F S 61.78F TO POB

Lat/Long

[33.577693 | -111.92763](#)

Lot Size

205,952 sq ft.

Zoning

C-2

Lot #

High School District

SCOTTSDALE UNIFIED #48

Elementary School District

SCOTTSDALE UNIFIED SCHOOL DISTRICT

Local Jurisdiction

SCOTTSDALE

S/T/R

27 3N 4E

Market

00/

Area/Neighborhood

Subdivision (0 Parcels)

OWNER INFORMATION



[ACACIA CREEK PARTNERS LLC](#)

Mailing Address 34975 W TWELVE MILE RD, FARMINGTON HILLS, MI 48331
Deed Number [121060742](#)
Last Deed Date 11/21/2012
Sale Date n/a
Sale Price n/a

VALUATION INFORMATION



We provide valuation information for the past 5 years. For mobile display, we only show 1 year of valuation information. Should you need more data, please look at our [data sales](#).

The Valuation Information displayed below may not reflect the taxable value used on the tax bill due to any special valuation relief program. [CLICK HERE TO PAY YOUR TAXES OR VIEW YOUR TAX BILL](#)

Tax Year	2022	2021	2020	2019	2018
Full Cash Value [?]	\$7,970,400	\$7,969,800	\$7,444,400	\$7,146,400	\$6,604,200
Limited Value [?]	\$5,234,773	\$4,985,498	\$4,748,093	\$4,521,993	\$4,306,660
Legal Class	1.12	1.12	1.12	1.12	1.12
Description	COMMERCIAL / OTHER R/P	COMMERCIAL / OTHER R/P	COMMERCIAL / OTHER R/P	COMMERCIAL / OTHER R/P	COMMERCIAL / OTHER R/P
Assessment Ratio	17.5%	18.0%	18.0%	18.0%	18.0%
Assessed LPV	\$916,085	\$897,390	\$854,657	\$813,959	\$775,199
Property Use Code	1130	1130	1130	1130	1130
PU Description	Retail	Retail	Retail	Retail	Retail
Tax Area Code	481400	481400	481400	481400	481400
Valuation Source	Notice	Notice	Notice	Notice	Notice

ADDITIONAL PROPERTY INFORMATION



Additional property data.

Description	Imp #	Occupancy	Rank	CCI	Age	Sq Ft.
Neighborhood Shopping Ctr	000101	412	2	C	26	27,581
Site Improvements	000201	163	2	D	26	1

BUILDING SKETCHES



Sketches that illustrate the external dimensions of a property.

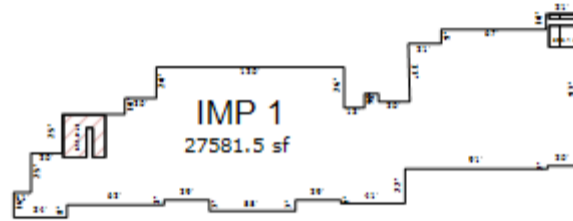

MAP FERRET MAPS



Mapferret maps, also known as Mapld maps, pdf maps, or output maps are now available here without having to search.

▶ [Parcel Maps \(1\)](#)

▶ [Book/Map Maps \(3\)](#)

CAUTION! USERS SHOULD INDEPENDENTLY RESEARCH AND VERIFY INFORMATION ON THIS WEBSITE BEFORE RELYING ON IT.

The Assessor's Office has compiled information on this website that it uses to identify, classify, and value real and personal property. Please contact the Maricopa County S.T.A.R. Center at (602) 506-3406 if you believe any information is incomplete, out of date, or incorrect so that appropriate corrections can be addressed. Please note that a statutory process is also available to correct errors pursuant to Arizona Revised Statutes 42-16254.

The Assessor does not guarantee that any information provided on this website is accurate, complete, or current. In many instances, the Assessor has gathered information from independent sources and made it available on this site, and the original information may have contained errors and omissions. Errors and omissions may also have occurred in the process of gathering, interpreting, and reporting the information. Information on the website is not updated in "real time". In addition, users are cautioned that the process used on this site to illustrate the boundaries of the adjacent parcels is not always consistent with the recorded documents for such parcels. The parcel boundaries depicted on this site are for illustrative purposes only, and the exact relationship of adjacent parcels should be independently researched and verified. The information provided on this site is not the equivalent of a title report or a real estate survey. Users should independently research, investigate and verify all information before relying on it or in the preparation of legal documents.

By using this website, you acknowledge having read the above and waive any right you may have to claim against Maricopa County, its officers, employees, and contractors arising out of my reliance on or the use of the information provided on this website.



Appendix D – Traffic Count Data



(303) 216-2439
www.alltrafficdata.net

Location: 3 DWY 400FT E.O SCOTTSDALE & GOLD DUST AVE AM

Date: Tuesday, March 1, 2022

Peak Hour: 07:00 AM - 08:00 AM

Peak 15-Minutes: 07:30 AM - 07:45 AM

Peak Hour - Motorized Vehicles

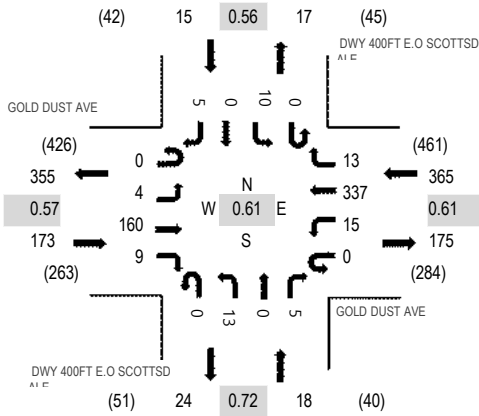

Peak Hour - Bicycles

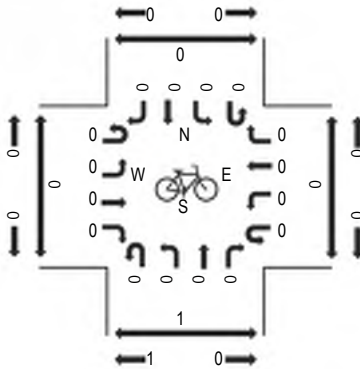

Peak Hour - Pedestrians

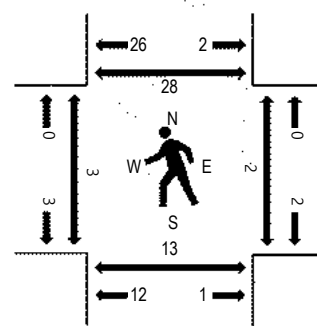

Note: Total study counts contained in parentheses.

Traffic Counts - Motorized Vehicles

Interval Start Time	GOLD DUST AVE Eastbound				GOLD DUST AVE Westbound				DWY 400FT E.O SCOTTSDALE Northbound				DWY 400FT E.O SCOTTSDALE Southbound				Total	Rolling Hour	Pedestrian Crossings			
	U-Turn	Left	Thru	Right	U-Turn	Left	Thru	Right	U-Turn	Left	Thru	Right	U-Turn	Left	Thru	Right			West	East	South	North
7:00 AM	0	1	15	0	0	2	37	2	0	1	0	0	0	3	0	1	62	571	0	0	0	1
7:15 AM	0	1	32	5	0	8	124	6	0	6	0	3	0	1	0	0	186	555	0	2	6	12
7:30 AM	0	2	72	2	0	5	143	2	0	3	0	0	0	3	0	3	235	429	3	0	6	14
7:45 AM	0	0	41	2	0	0	33	3	0	3	0	2	0	3	0	1	88	260	0	0	1	1
8:00 AM	0	1	15	1	0	3	10	5	0	1	0	8	0	1	0	1	46	235	0	1	2	2
8:15 AM	0	2	15	0	0	4	16	5	0	1	1	4	0	7	1	4	60		0	0	0	0
8:30 AM	0	2	26	2	0	2	23	5	0	0	0	0	0	5	0	1	66		0	0	0	0
8:45 AM	0	2	18	6	0	8	11	4	0	2	1	4	0	6	0	1	63		0	0	3	2
Count Total	0	11	234	18	0	32	397	32	0	17	2	21	0	29	1	12	806		3	3	18	32
Peak Hour	0	4	160	9	0	15	337	13	0	13	0	5	0	10	0	5	571		3	2	13	28



(303) 216-2439
www.alltrafficdata.net

Location: 4 SCOTTSDALE RD & GOLD DUST AVE AM

Date: Tuesday, March 1, 2022

Peak Hour: 07:30 AM - 08:30 AM

Peak 15-Minutes: 07:30 AM - 07:45 AM

Peak Hour - Motorized Vehicles

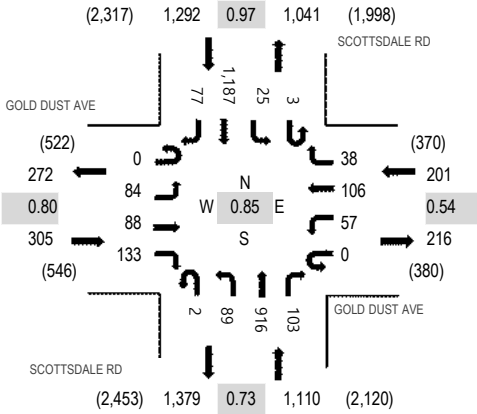

Peak Hour - Bicycles

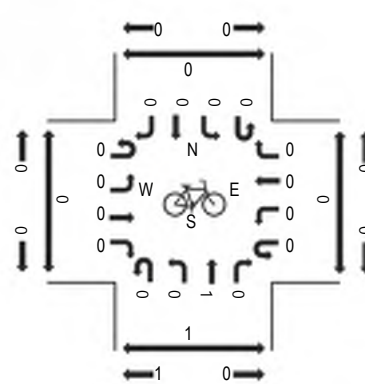

Peak Hour - Pedestrians

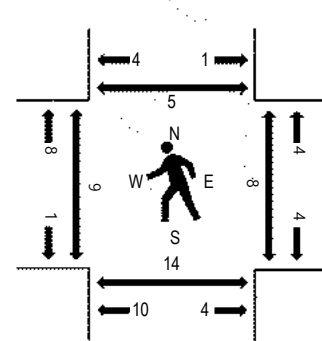

Note: Total study counts contained in parentheses.

Traffic Counts - Motorized Vehicles

Interval Start Time	GOLD DUST AVE Eastbound				GOLD DUST AVE Westbound				SCOTTSDALE RD Northbound			SCOTTSDALE RD Southbound				Total	Rolling Hour	Pedestrian Crossings				
	U-Turn	Left	Thru	Right	U-Turn	Left	Thru	Right	U-Turn	Left	Thru	Right	U-Turn	Left	Thru			Right	West	East	South	North
7:00 AM	0	14	17	16	0	9	10	8	0	12	94	11	2	4	156	19	372	2,588	0	1	0	2
7:15 AM	0	12	24	23	0	11	51	7	0	42	181	14	0	4	203	45	617	2,868	0	1	1	1
7:30 AM	0	29	36	31	0	16	80	14	1	39	251	25	1	6	273	52	854	2,908	4	4	3	3
7:45 AM	0	23	24	40	0	12	9	8	1	15	257	26	0	6	312	12	745	2,702	1	0	0	0
8:00 AM	0	21	13	31	0	12	9	9	0	22	201	26	1	5	297	5	652	2,765	0	2	5	1
8:15 AM	0	11	15	31	0	17	8	7	0	13	207	26	1	8	305	8	657		4	2	6	1
8:30 AM	0	22	22	28	0	13	9	7	0	13	232	16	1	6	275	4	648		1	1	3	2
8:45 AM	0	15	16	32	0	21	12	11	1	22	350	22	1	8	286	11	808		0	0	0	2
Count Total	0	147	167	232	0	111	188	71	3	178	1,773	166	7	47	2,107	156	5,353		10	11	18	12
Peak Hour	0	84	88	133	0	57	106	38	2	89	916	103	3	25	1,187	77	2,908		9	8	14	5



(303) 216-2439
www.alltrafficdata.net

Location: 5 SCOTTSDALE RD & DWY 300FT S.O GOLD DUST AM

Date: Tuesday, March 1, 2022

Peak Hour: 07:30 AM - 08:30 AM

Peak 15-Minutes: 07:45 AM - 08:00 AM

Peak Hour - Motorized Vehicles

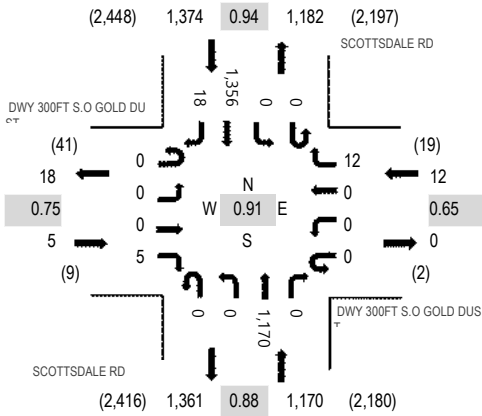

Peak Hour - Bicycles

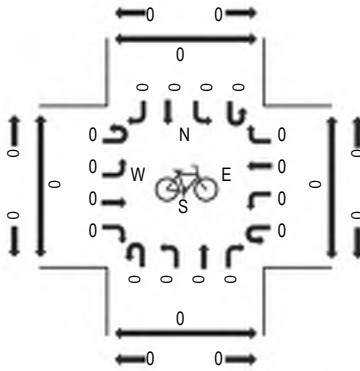

Peak Hour - Pedestrians

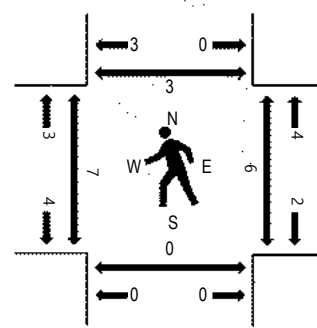

Note: Total study counts contained in parentheses.

Traffic Counts - Motorized Vehicles

Interval Start Time	DWY 300FT S.O GOLD DUST Eastbound				DWY 300FT S.O GOLD DUST Westbound				SCOTTSDALE RD Northbound				SCOTTSDALE RD Southbound				Total	Rolling Hour	Pedestrian Crossings				
	U-Turn	Left	Thru	Right	U-Turn	Left	Thru	Right	U-Turn	Left	Thru	Right	U-Turn	Left	Thru	Right			West	East	South	North	
7:00 AM	0	0	0	0	0	0	0	0	1	0	0	172	0	0	0	166	10	349	2,184	1	1	0	0
7:15 AM	0	0	0	1	0	0	0	0	1	0	0	259	1	0	0	229	10	501	2,422	2	2	0	0
7:30 AM	0	0	0	1	0	0	0	0	5	0	0	306	0	0	0	308	11	631	2,561	3	0	0	2
7:45 AM	0	0	0	2	0	0	0	0	2	0	0	334	0	0	0	364	1	703	2,525	2	2	0	0
8:00 AM	0	0	0	0	0	0	0	0	5	0	0	242	0	0	0	338	2	587	2,472	1	2	0	0
8:15 AM	0	0	0	2	0	0	0	0	0	0	0	288	0	0	0	346	4	640		1	2	0	1
8:30 AM	0	0	0	2	0	0	0	0	2	0	0	274	0	0	0	316	1	595		1	1	0	0
8:45 AM	0	0	0	1	0	0	0	0	3	0	0	303	1	0	0	340	2	650		0	3	0	0
Count Total	0	0	0	9	0	0	0	0	19	0	0	2,178	2	0	0	2,407	41	4,656		11	13	0	3
Peak Hour	0	0	0	5	0	0	0	0	12	0	0	1,170	0	0	0	1,356	18	2,561		7	6	0	3



(303) 216-2439
www.alltrafficdata.net

Location: 6 SCOTTSDALE RD & ACACIA DR AM

Date: Tuesday, March 1, 2022

Peak Hour: 07:45 AM - 08:45 AM

Peak 15-Minutes: 07:45 AM - 08:00 AM

Peak Hour - Motorized Vehicles

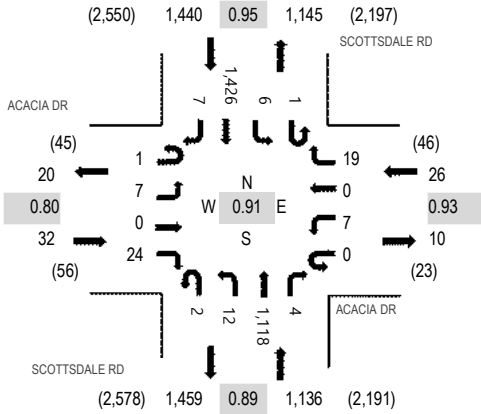

Peak Hour - Bicycles

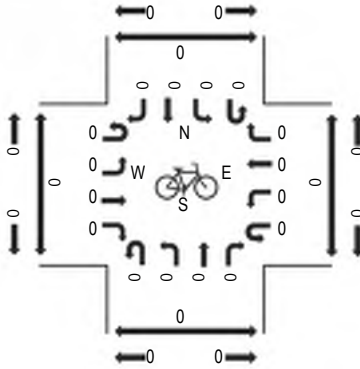

Peak Hour - Pedestrians

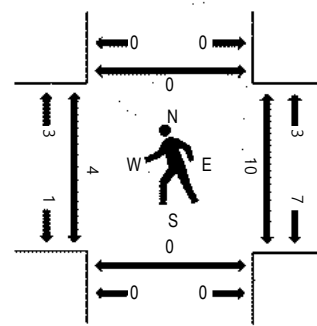

Note: Total study counts contained in parentheses.

Traffic Counts - Motorized Vehicles

Interval Start Time	ACACIA DR Eastbound				ACACIA DR Westbound				SCOTTSDALE RD Northbound				SCOTTSDALE RD Southbound				Total	Rolling Hour	Pedestrian Crossings			
	U-Turn	Left	Thru	Right	U-Turn	Left	Thru	Right	U-Turn	Left	Thru	Right	U-Turn	Left	Thru	Right			West	East	South	North
7:00 AM	0	2	0	3	0	1	0	6	0	4	167	1	0	1	200	0	385	2,268	0	1	0	0
7:15 AM	0	3	0	4	0	0	0	7	1	8	250	1	0	1	246	1	522	2,477	1	2	0	0
7:30 AM	0	1	0	5	0	1	0	4	0	4	303	1	0	3	311	2	635	2,624	5	0	0	0
7:45 AM	0	3	0	7	0	2	0	5	0	4	324	1	0	4	373	3	726	2,634	2	2	0	0
8:00 AM	0	3	0	5	0	2	0	4	1	2	240	1	0	0	334	2	594	2,575	1	2	0	0
8:15 AM	0	0	0	8	0	2	0	5	0	3	285	2	0	1	363	0	669		0	2	0	0
8:30 AM	1	1	0	4	0	1	0	5	1	3	269	0	1	1	356	2	645		1	4	0	0
8:45 AM	0	1	0	5	0	0	0	1	1	6	305	3	2	2	341	0	667		0	1	0	0
Count Total	1	14	0	41	0	9	0	37	4	34	2,143	10	3	13	2,524	10	4,843		10	14	0	0
Peak Hour	1	7	0	24	0	7	0	19	2	12	1,118	4	1	6	1,426	7	2,634		4	10	0	0



(303) 216-2439
www.alltrafficdata.net

Location: 3 DWY 400FT E.O SCOTTSDALE & GOLD DUST AVE PM

Date: Tuesday, March 1, 2022

Peak Hour: 05:00 PM - 06:00 PM

Peak 15-Minutes: 05:15 PM - 05:30 PM

Peak Hour - Motorized Vehicles

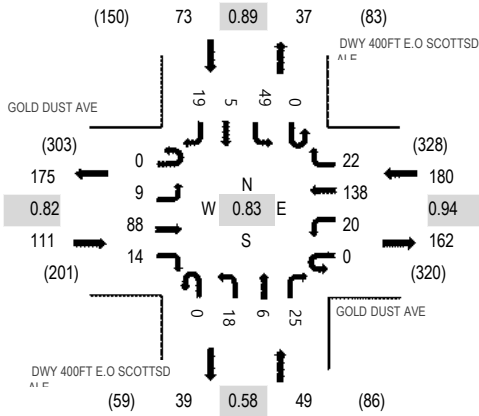

Peak Hour - Bicycles

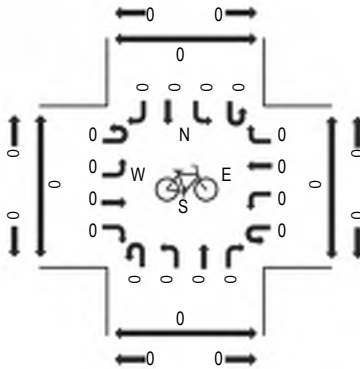

Peak Hour - Pedestrians

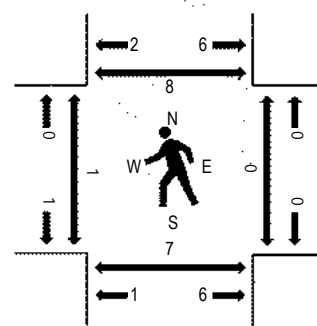

Note: Total study counts contained in parentheses.

Traffic Counts - Motorized Vehicles

Interval Start Time	GOLD DUST AVE Eastbound				GOLD DUST AVE Westbound				DWY 400FT E.O SCOTTSDALE Northbound				DWY 400FT E.O SCOTTSDALE Southbound				Total	Rolling Hour	Pedestrian Crossings			
	U-Turn	Left	Thru	Right	U-Turn	Left	Thru	Right	U-Turn	Left	Thru	Right	U-Turn	Left	Thru	Right			West	East	South	North
4:00 PM	0	2	25	2	0	1	23	7	0	3	3	1	0	10	1	3	81	352	0	1	5	5
4:15 PM	0	2	14	3	0	3	25	11	0	3	3	10	0	17	2	4	97	384	0	0	0	2
4:30 PM	0	1	19	1	0	2	27	8	0	0	1	5	0	21	0	3	88	412	1	0	0	5
4:45 PM	0	2	18	1	0	4	31	6	0	4	0	4	0	14	0	2	86	405	0	0	1	2
5:00 PM	0	2	26	4	0	2	40	4	0	5	1	7	0	18	2	2	113	413	0	0	1	0
5:15 PM	0	1	29	4	0	9	32	7	0	8	3	10	0	15	1	6	125		0	0	0	5
5:30 PM	0	2	14	3	0	2	34	6	0	2	1	3	0	7	1	6	81		1	0	6	3
5:45 PM	0	4	19	3	0	7	32	5	0	3	1	5	0	9	1	5	94		0	0	0	0
Count Total	0	16	164	21	0	30	244	54	0	28	13	45	0	111	8	31	765		2	1	13	22
Peak Hour	0	9	88	14	0	20	138	22	0	18	6	25	0	49	5	19	413		1	0	7	8



(303) 216-2439
www.alltrafficdata.net

Location: 4 SCOTTSDALE RD & GOLD DUST AVE PM

Date: Tuesday, March 1, 2022

Peak Hour: 04:45 PM - 05:45 PM

Peak 15-Minutes: 05:00 PM - 05:15 PM

Peak Hour - Motorized Vehicles

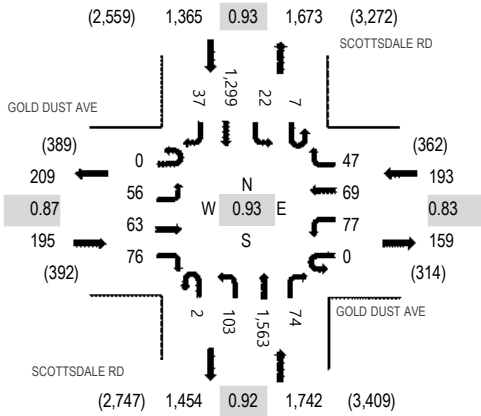

Peak Hour - Bicycles

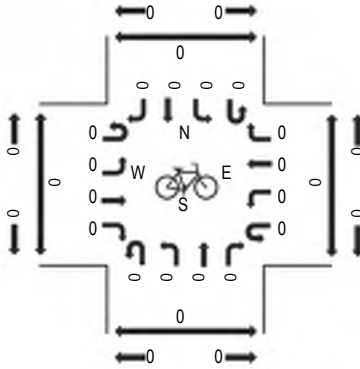

Peak Hour - Pedestrians

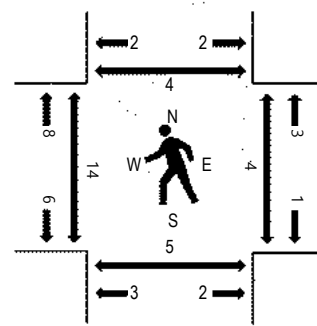

Note: Total study counts contained in parentheses.

Traffic Counts - Motorized Vehicles

Interval Start Time	GOLD DUST AVE Eastbound				GOLD DUST AVE Westbound				SCOTTSDALE RD Northbound				SCOTTSDALE RD Southbound				Total	Rolling Hour	Pedestrian Crossings			
	U-Turn	Left	Thru	Right	U-Turn	Left	Thru	Right	U-Turn	Left	Thru	Right	U-Turn	Left	Thru	Right			West	East	South	North
4:00 PM	0	13	14	20	0	15	9	11	0	30	451	26	0	6	292	9	896	3,349	0	0	0	0
4:15 PM	0	22	12	23	0	23	12	16	1	26	368	15	3	14	283	5	823	3,389	5	0	0	2
4:30 PM	0	17	14	23	0	20	15	8	1	22	383	17	1	2	274	8	805	3,451	1	0	0	0
4:45 PM	0	18	19	13	0	23	21	14	0	28	352	19	0	3	309	6	825	3,495	5	0	2	1
5:00 PM	0	16	14	24	0	19	17	5	0	23	431	21	3	10	343	10	936	3,373	4	1	0	0
5:15 PM	0	14	24	26	0	20	19	12	2	26	381	16	1	6	330	8	885		1	1	2	3
5:30 PM	0	8	6	13	0	15	12	16	0	26	399	18	3	3	317	13	849		4	2	1	0
5:45 PM	0	9	16	14	0	22	12	6	1	22	288	16	3	3	281	10	703		4	4	0	1
Count Total	0	117	119	156	0	157	117	88	5	203	3,053	148	14	47	2,429	69	6,722		24	8	5	7
Peak Hour	0	56	63	76	0	77	69	47	2	103	1,563	74	7	22	1,299	37	3,495		14	4	5	4



(303) 216-2439
www.alltrafficdata.net

Location: 5 SCOTTSDALE RD & DWY 300FT S.O GOLD DUST PM

Date: Tuesday, March 1, 2022

Peak Hour: 04:45 PM - 05:45 PM

Peak 15-Minutes: 05:00 PM - 05:15 PM

Peak Hour - Motorized Vehicles

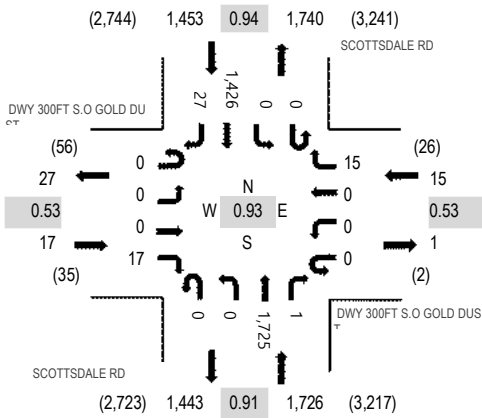

Peak Hour - Bicycles

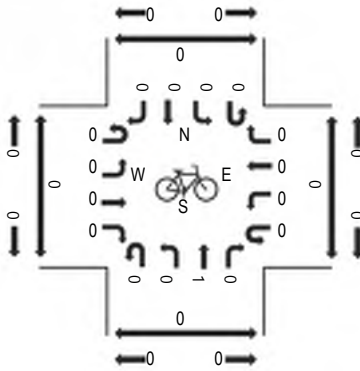

Peak Hour - Pedestrians

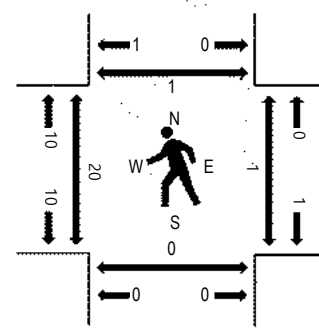

Note: Total study counts contained in parentheses.

Traffic Counts - Motorized Vehicles

Interval Start Time	DWY 300FT S.O GOLD DUST Eastbound				DWY 300FT S.O GOLD DUST Westbound				SCOTTSDALE RD Northbound				SCOTTSDALE RD Southbound				Total	Rolling Hour	Pedestrian Crossings			
	U-Turn	Left	Thru	Right	U-Turn	Left	Thru	Right	U-Turn	Left	Thru	Right	U-Turn	Left	Thru	Right			West	East	South	North
4:00 PM	0	0	0	5	0	0	0	2	0	0	339	0	0	0	316	11	673	2,908	3	0	0	0
4:15 PM	0	0	0	9	0	0	0	4	0	0	400	0	0	0	324	5	742	3,102	4	1	0	0
4:30 PM	0	0	0	0	0	0	0	2	0	0	425	1	0	0	310	7	745	3,161	1	0	0	0
4:45 PM	0	0	0	5	0	0	0	5	0	0	393	0	0	0	341	4	748	3,211	4	0	0	0
5:00 PM	0	0	0	3	0	0	0	2	0	0	476	0	0	0	381	5	867	3,114	6	1	0	1
5:15 PM	0	0	0	5	0	0	0	8	0	0	412	0	0	0	368	8	801		2	0	0	0
5:30 PM	0	0	0	4	0	0	0	0	0	0	444	1	0	0	336	10	795		8	0	0	0
5:45 PM	0	0	0	4	0	0	0	3	0	0	326	0	0	0	312	6	651		5	0	0	0
Count Total	0	0	0	35	0	0	0	26	0	0	3,215	2	0	0	2,688	56	6,022		33	2	0	1
Peak Hour	0	0	0	17	0	0	0	15	0	0	1,725	1	0	0	1,426	27	3,211		20	1	0	1



(303) 216-2439
www.alltrafficdata.net

Location: 6 SCOTTSDALE RD & ACACIA DR PM

Date: Tuesday, March 1, 2022

Peak Hour: 04:45 PM - 05:45 PM

Peak 15-Minutes: 05:00 PM - 05:15 PM

Peak Hour - Motorized Vehicles

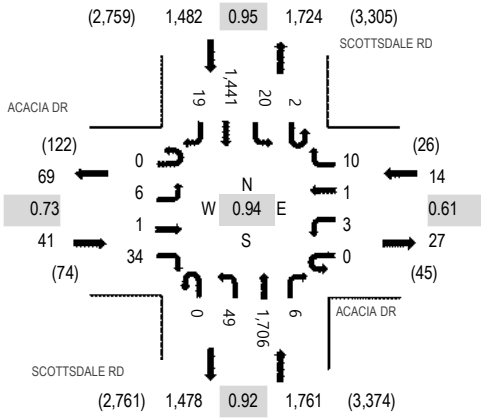

Peak Hour - Bicycles

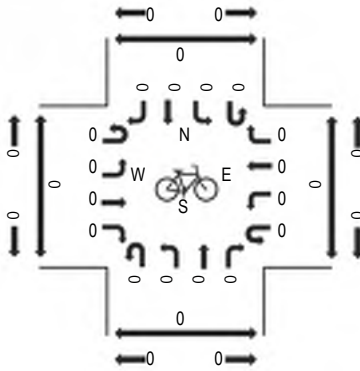

Peak Hour - Pedestrians

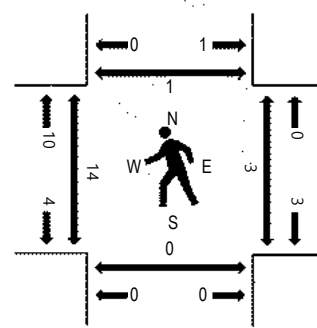

Note: Total study counts contained in parentheses.

Traffic Counts - Motorized Vehicles

Interval Start Time	ACACIA DR Eastbound				ACACIA DR Westbound				SCOTTSDALE RD Northbound				SCOTTSDALE RD Southbound				Total	Rolling Hour	Pedestrian Crossings			
	U-Turn	Left	Thru	Right	U-Turn	Left	Thru	Right	U-Turn	Left	Thru	Right	U-Turn	Left	Thru	Right			West	East	South	North
4:00 PM	0	1	0	5	0	0	0	3	0	12	427	1	0	5	321	4	779	3,047	0	0	0	0
4:15 PM	0	1	0	8	0	2	0	1	0	12	403	2	2	2	316	3	752	3,147	6	1	0	0
4:30 PM	0	0	0	8	0	0	0	2	1	9	417	3	0	4	307	2	753	3,214	3	0	0	0
4:45 PM	0	1	0	9	0	0	0	1	0	9	393	0	1	3	344	2	763	3,298	3	0	0	0
5:00 PM	0	1	0	7	0	1	0	6	0	11	461	4	0	5	377	6	879	3,186	6	1	0	0
5:15 PM	0	3	1	10	0	0	1	3	0	19	407	2	0	8	360	5	819		2	0	0	0
5:30 PM	0	1	0	8	0	2	0	0	0	10	445	0	1	4	360	6	837		3	2	0	1
5:45 PM	0	2	0	8	0	0	0	4	0	8	317	1	1	0	307	3	651		12	0	0	2
Count Total	0	10	1	63	0	5	1	20	1	90	3,270	13	5	31	2,692	31	6,233		35	4	0	3
Peak Hour	0	6	1	34	0	3	1	10	0	49	1,706	6	2	20	1,441	19	3,298		14	3	0	1

Start Time	01-Mar-22 Tue	EB	WB							Total
12:00 AM		2	7							9
01:00		2	5							7
02:00		1	3							4
03:00		0	4							4
04:00		8	0							8
05:00		25	9							34
06:00		55	71							126
07:00		171	355							526
08:00		87	73							160
09:00		68	99							167
10:00		71	103							174
11:00		115	97							212
12:00 PM		64	103							167
01:00		91	128							219
02:00		194	200							394
03:00		120	129							249
04:00		92	127							219
05:00		109	177							286
06:00		69	130							199
07:00		42	75							117
08:00		36	68							104
09:00		15	39							54
10:00		19	22							41
11:00		6	20							26
Total		1462	2044							3506
Percent		41.7%	58.3%							
AM Peak	-	07:00	07:00	-	-	-	-	-	-	07:00
Vol.	-	171	355	-	-	-	-	-	-	526
PM Peak	-	14:00	14:00	-	-	-	-	-	-	14:00
Vol.	-	194	200	-	-	-	-	-	-	394
Grand Total		1462	2044							3506
Percent		41.7%	58.3%							
ADT		ADT 3,506	AADT 3,506							

Site Code: 7
SCOTTSDALE RD S.O GOLD DUST AVE

Start Time	01-Mar-22 Tue	NB	SB							Total
12:00 AM		90	76							166
01:00		47	32							79
02:00		46	29							75
03:00		34	35							69
04:00		63	73							136
05:00		142	196							338
06:00		381	444							825
07:00		889	1005							1894
08:00		941	1213							2154
09:00		1007	1036							2043
10:00		1112	995							2107
11:00		1191	1116							2307
12:00 PM		1150	1201							2351
01:00		1274	1093							2367
02:00		1283	1114							2397
03:00		1248	1207							2455
04:00		1283	1143							2426
05:00		1311	1262							2573
06:00		1009	923							1932
07:00		763	683							1446
08:00		573	486							1059
09:00		499	382							881
10:00		290	217							507
11:00		158	114							272
Total		16784	16075							32859
Percent		51.1%	48.9%							
AM Peak	-	11:00	08:00	-	-	-	-	-	-	11:00
Vol.	-	1191	1213	-	-	-	-	-	-	2307
PM Peak	-	17:00	17:00	-	-	-	-	-	-	17:00
Vol.	-	1311	1262	-	-	-	-	-	-	2573
Grand Total		16784	16075							32859
Percent		51.1%	48.9%							
ADT		ADT 32,859	AADT 32,859							



Appendix E – Signal Timing

SCOTTSDALE & GOLDDUST			System # 102
BASIC TIMING PLAN	Section #	I.P. Address	Date Designed
		MM1-5-1 172.27.11.02	6/28/2021

TIMING PLAN - MM-2-1	Phase	1	2		4	5	6		8
	Movement	NBL	SBT		WBT	SBL	NBT		EBT
	NOTES	p&P	COORD			p&P	COORD		
	MIN GRN	5	10		7	5	10		7
	BK MGRN								
	CS MGRN								
	DLY GRN								
	WALK		4		4		4		4
	WALK2		7		7		7		7
	WLK MAX								
	PED CLR/FDW		22		23		19		28
	PD CLR2								
	PC MAX								
	PED CO								
	VEH EXT	2	1		2	2	1		2
	VH EXT2								
	MAX 1	15	65		45	15	65		45
	MAX 2	25	75		50	25	75		50
	MAX 3								
	DYM MAX								
DYM STP									
YELLOW	4	4.7		4	4	4.7		4	
RED CLR	2	1.0		1.4	2	1.0		1.4	
RED MAX									
RED RVT	2	2		2	2	2		2	
ACT B4									
SEC/ACT									
MAX INT									
TIME B4									
CARS WT									
STPTDUC									
TTREDUC									
MIN GAP									
RECALLS - MM-2-8	LOCK DET								
	VEH RECALL		X			X			
	PED RECALL								
	MAX RECALL								
	SOFT RECALL								
	NO REST								
ADD INIT CAL									

NOTES

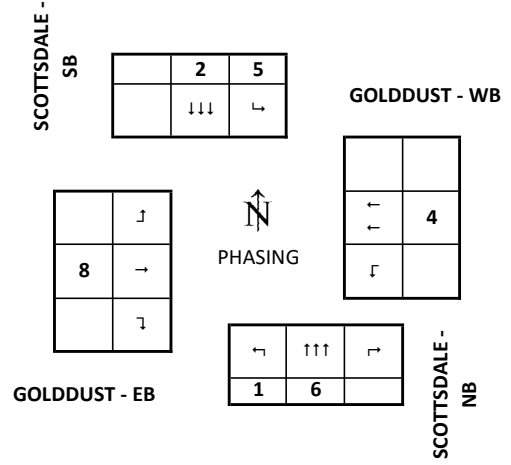

PHASING SEQUENCES	
TOD: MORNING	
R1	2 1 4
R2	6 5 8
Use Timing plan:	
TOD: MIDDAY	
R1	2 1 4
R2	6 5 8
Use Timing plan:	
TOD: EVENING	
R1	2 1 4
R2	6 5 8
Use Timing plan:	
TOD: NIGHT	
R1	2 1 4
R2	6 5 8
Use Timing plan:	
FREE	
R1	2 1 4
R2	6 5 8
Use Timing plan: 254	

Approved By
Effective Date 6/21/2021

SCOTTSDALE & GOLDDUST

System #

102

COORDINATOR

Section #

0

Date Updated

6/28/2021

PHASE	1	2	3	4	5	6	7	8
FDW		22		23		19		28
YELLOW	4	4.7		4	4	4.7		4
ALL RED	2	1		1.4	2	1		1.4
WALK		22		23		19		28

PLAN 1 AM PLAN OPERATIVE TIMES 6:00	R1	2	↓	1	↶	4	←			COORD PATTERN	OFFSET
	R2	6	↑	5	↷	8	→			Balanced	110
		RING 1				RING 2					
	PHASE	1	2		4	5	6		8		
	SPLIT	13	77		30	13	77		30	Target Cycle Length	
	COORD		X				X			120	
	RECALLS		V				V			Actual Cycle Length	
	GREEN	7.0	71.3		24.6	7.0	71.3		24.6	120	

PLAN 2 MIDDAY PLAN OPERATIVE TIMES 9:00	R1	2	↓	1	↶	4	←			COORD PATTERN	OFFSET
	R2	6	↑	5	↷	8	→			Balanced	46
		RING 1				RING 2					
	PHASE	1	2		4	5	6		8		
	SPLIT	14	67		27	14	67		27	Target Cycle Length	
	COORD		X				X			108	
	RECALLS		V				V			Actual Cycle Length	
	GREEN	8.0	61.3		21.6	8.0	61.3		21.6	108	

PLAN 3 PM PLAN OPERATIVE TIMES 15:00	R1	2	↓	1	↶	4	←			COORD PATTERN	OFFSET
	R2	6	↑	5	↷	8	→			Balanced	55
		RING 1				RING 2					
	PHASE	1	2		4	5	6		8		
	SPLIT	13	80		27	13	80		27	Target Cycle Length	
	COORD		X				X			120	
	RECALLS		V				V			Actual Cycle Length	
	GREEN	7.0	74.3		21.6	7.0	74.3		21.6	120	

PLAN 10 MIDNIGHT PLAN OPERATIVE TIMES	R1	2	↓	1	↶	4	←			COORD PATTERN	OFFSET
	R2	6	↑	5	↷	8	→			Balanced	75
		RING 1				RING 2					
	PHASE	1	2		4	5	6		8		
	SPLIT	11	53		26	11	53		26	Target Cycle Length	
	COORD		X				X			90	
	RECALLS		V				V			Actual Cycle Length	
	GREEN	5.0	47.3		20.6	5.0	47.3		20.6	90	



Appendix F – Existing Capacity Analysis

Intersection												
Int Delay, s/veh	2.1											
Movement	EBL	EBT	EBR	WBL	WBT	WBR	NBL	NBT	NBR	SBL	SBT	SBR
Lane Configurations	↶	↷		↶	↷		↕	↕		↕	↕	
Traffic Vol, veh/h	5	138	5	12	195	15	8	1	14	14	1	9
Future Vol, veh/h	5	138	5	12	195	15	8	1	14	14	1	9
Conflicting Peds, #/hr	0	0	0	0	0	0	0	0	0	0	0	0
Sign Control	Free	Free	Free	Free	Free	Free	Stop	Stop	Stop	Stop	Stop	Stop
RT Channelized	-	-	None	-	-	None	-	-	None	-	-	None
Storage Length	100	-	-	100	-	-	-	-	-	-	-	-
Veh in Median Storage, #	-	0	-	-	0	-	-	0	-	-	0	-
Grade, %	-	0	-	-	0	-	-	0	-	-	0	-
Peak Hour Factor	46	46	46	46	46	46	46	46	46	46	46	46
Heavy Vehicles, %	2	2	2	2	2	2	2	2	2	2	2	2
Mvmt Flow	11	300	11	26	424	33	17	2	30	30	2	20

Major/Minor	Major1			Major2			Minor1			Minor2		
Conflicting Flow All	457	0	0	311	0	0	832	837	306	837	826	441
Stage 1	-	-	-	-	-	-	328	328	-	493	493	-
Stage 2	-	-	-	-	-	-	504	509	-	344	333	-
Critical Hdwy	4.12	-	-	4.12	-	-	7.12	6.52	6.22	7.12	6.52	6.22
Critical Hdwy Stg 1	-	-	-	-	-	-	6.12	5.52	-	6.12	5.52	-
Critical Hdwy Stg 2	-	-	-	-	-	-	6.12	5.52	-	6.12	5.52	-
Follow-up Hdwy	2.218	-	-	2.218	-	-	3.518	4.018	3.318	3.518	4.018	3.318
Pot Cap-1 Maneuver	1104	-	-	1249	-	-	288	303	734	286	307	616
Stage 1	-	-	-	-	-	-	685	647	-	558	547	-
Stage 2	-	-	-	-	-	-	550	538	-	671	644	-
Platoon blocked, %	-	-	-	-	-	-	-	-	-	-	-	-
Mov Cap-1 Maneuver	1104	-	-	1249	-	-	271	294	734	266	297	616
Mov Cap-2 Maneuver	-	-	-	-	-	-	271	294	-	266	297	-
Stage 1	-	-	-	-	-	-	678	641	-	552	536	-
Stage 2	-	-	-	-	-	-	519	527	-	635	638	-

Approach	EB			WB			NB			SB		
HCM Control Delay, s	0.3			0.4			14.2			17.5		
HCM LOS							B			C		

Minor Lane/Major Mvmt	NBLn1	EBL	EBT	EBR	WBL	WBT	WBR	SBLn1
Capacity (veh/h)	442	1104	-	-	1249	-	-	340
HCM Lane V/C Ratio	0.113	0.01	-	-	0.021	-	-	0.153
HCM Control Delay (s)	14.2	8.3	-	-	7.9	-	-	17.5
HCM Lane LOS	B	A	-	-	A	-	-	C
HCM 95th %tile Q(veh)	0.4	0	-	-	0.1	-	-	0.5

2: Scottsdale Road & Gold Dust Avenue

06/15/2022



Movement	EBL	EBT	EBR	WBL	WBT	WBR	NBL	NBT	NBR	SBL	SBT	SBR
Lane Configurations	↖	↑	↗	↖	↕		↖	↕	↗	↖	↕	↗
Traffic Volume (veh/h)	81	85	128	55	102	37	88	881	100	27	1142	75
Future Volume (veh/h)	81	85	128	55	102	37	88	881	100	27	1142	75
Initial Q (Qb), veh	0	0	0	0	0	0	0	0	0	0	0	0
Ped-Bike Adj(A_pbT)	1.00		1.00	1.00		1.00	1.00		1.00	1.00		1.00
Parking Bus, Adj	1.00	1.00	1.00	1.00	1.00	1.00	1.00	1.00	1.00	1.00	1.00	1.00
Work Zone On Approach		No			No			No			No	
Adj Sat Flow, veh/h/ln	1870	1870	1870	1870	1870	1870	1870	1870	1870	1870	1870	1870
Adj Flow Rate, veh/h	95	100	151	65	120	44	104	1036	118	32	1344	88
Peak Hour Factor	0.85	0.85	0.85	0.85	0.85	0.85	0.85	0.85	0.85	0.85	0.85	0.85
Percent Heavy Veh, %	2	2	2	2	2	2	2	2	2	2	2	2
Cap, veh/h	179	264	224	164	364	128	787	1157	359	944	1508	99
Arrive On Green	0.14	0.14	0.14	0.14	0.14	0.14	0.82	0.45	0.45	0.49	0.31	0.31
Sat Flow, veh/h	1222	1870	1585	1129	2578	906	1781	5106	1585	1781	4896	321
Grp Volume(v), veh/h	95	100	151	65	81	83	104	1036	118	32	934	498
Grp Sat Flow(s),veh/h/ln	1222	1870	1585	1129	1777	1707	1781	1702	1585	1781	1702	1813
Q Serve(g_s), s	9.1	5.8	10.9	6.7	4.9	5.3	0.0	22.4	5.7	0.0	31.4	31.4
Cycle Q Clear(g_c), s	14.4	5.8	10.9	12.5	4.9	5.3	0.0	22.4	5.7	0.0	31.4	31.4
Prop In Lane	1.00		1.00	1.00		0.53	1.00		1.00	1.00		0.18
Lane Grp Cap(c), veh/h	179	264	224	164	251	241	787	1157	359	944	1049	558
V/C Ratio(X)	0.53	0.38	0.68	0.40	0.32	0.34	0.13	0.90	0.33	0.03	0.89	0.89
Avail Cap(c_a), veh/h	257	383	325	237	364	350	787	3034	942	944	2023	1077
HCM Platoon Ratio	1.00	1.00	1.00	1.00	1.00	1.00	2.00	2.00	2.00	1.00	1.00	1.00
Upstream Filter(I)	1.00	1.00	1.00	1.00	1.00	1.00	1.00	1.00	1.00	1.00	1.00	1.00
Uniform Delay (d), s/veh	53.0	46.8	48.9	52.4	46.4	46.5	6.5	31.5	27.0	15.1	39.6	39.6
Incr Delay (d2), s/veh	0.9	0.3	1.3	0.6	0.3	0.3	0.0	10.9	2.4	0.0	11.4	19.0
Initial Q Delay(d3),s/veh	0.0	0.0	0.0	0.0	0.0	0.0	0.0	0.0	0.0	0.0	0.0	0.0
%ile BackOfQ(50%),veh/ln	2.8	2.7	4.4	1.9	2.2	2.2	0.5	7.9	2.2	0.4	14.4	16.5
Unsig. Movement Delay, s/veh												
LnGrp Delay(d),s/veh	53.9	47.1	50.3	53.0	46.7	46.8	6.5	42.4	29.4	15.1	51.0	58.6
LnGrp LOS	D	D	D	D	D	D	A	D	C	B	D	E
Approach Vol, veh/h		346			229			1258			1464	
Approach Delay, s/veh		50.4			48.5			38.2			52.8	
Approach LOS		D			D			D			D	
Timer - Assigned Phs	1	2		4	5	6		8				
Phs Duration (G+Y+Rc), s	55.0	42.7		22.3	64.8	32.9		22.3				
Change Period (Y+Rc), s	6.0	5.7		* 5.4	6.0	5.7		* 5.4				
Max Green Setting (Gmax), s	7.0	71.3		* 25	7.0	71.3		* 25				
Max Q Clear Time (g_c+I1), s	2.0	33.4		14.5	2.0	24.4		16.4				
Green Ext Time (p_c), s	0.0	3.6		0.5	0.0	2.8		0.5				

Intersection Summary

HCM 6th Ctrl Delay	46.7
HCM 6th LOS	D

Notes

User approved pedestrian interval to be less than phase max green.
 * HCM 6th computational engine requires equal clearance times for the phases crossing the barrier.

3: Scottsdale Road & Driveway B

06/15/2022

Intersection												
Int Delay, s/veh	0.1											
Movement	EBL	EBT	EBR	WBL	WBT	WBR	NBL	NBT	NBR	SBL	SBT	SBR
Lane Configurations			↗			↗	↑↑↑			↑↑↑		
Traffic Vol, veh/h	0	0	5	0	0	12	0	1125	0	0	1304	18
Future Vol, veh/h	0	0	5	0	0	12	0	1125	0	0	1304	18
Conflicting Peds, #/hr	0	0	0	0	0	0	0	0	0	0	0	0
Sign Control	Stop	Stop	Stop	Stop	Stop	Stop	Free	Free	Free	Free	Free	Free
RT Channelized	-	-	None	-	-	None	-	-	None	-	-	None
Storage Length	-	-	0	-	-	0	-	-	-	-	-	-
Veh in Median Storage, #	-	0	-	-	0	-	-	0	-	-	0	-
Grade, %	-	0	-	-	0	-	-	0	-	-	0	-
Peak Hour Factor	91	91	91	91	91	91	91	91	91	91	91	91
Heavy Vehicles, %	2	2	2	2	2	2	2	2	2	2	2	2
Mvmt Flow	0	0	5	0	0	13	0	1236	0	0	1433	20

Major/Minor	Minor2		Minor1		Major1		Major2					
Conflicting Flow All	-	-	727	-	-	618	-	0	0	-	-	0
Stage 1	-	-	-	-	-	-	-	-	-	-	-	-
Stage 2	-	-	-	-	-	-	-	-	-	-	-	-
Critical Hdwy	-	-	7.14	-	-	7.14	-	-	-	-	-	-
Critical Hdwy Stg 1	-	-	-	-	-	-	-	-	-	-	-	-
Critical Hdwy Stg 2	-	-	-	-	-	-	-	-	-	-	-	-
Follow-up Hdwy	-	-	3.92	-	-	3.92	-	-	-	-	-	-
Pot Cap-1 Maneuver	0	0	*610	0	0	*653	0	-	-	0	-	-
Stage 1	0	0	-	0	0	-	0	-	-	0	-	-
Stage 2	0	0	-	0	0	-	0	-	-	0	-	-
Platoon blocked, %			1			1		-	-		-	-
Mov Cap-1 Maneuver	-	-	*610	-	-	*653	-	-	-	-	-	-
Mov Cap-2 Maneuver	-	-	-	-	-	-	-	-	-	-	-	-
Stage 1	-	-	-	-	-	-	-	-	-	-	-	-
Stage 2	-	-	-	-	-	-	-	-	-	-	-	-

Approach	EB	WB	NB	SB
HCM Control Delay, s	11	10.6	0	0
HCM LOS	B	B		

Minor Lane/Major Mvmt	NBT	NBR	EBLn1WBLn1	SBT	SBR
Capacity (veh/h)	-	-	610	653	-
HCM Lane V/C Ratio	-	-	0.009	0.02	-
HCM Control Delay (s)	-	-	11	10.6	-
HCM Lane LOS	-	-	B	B	-
HCM 95th %tile Q(veh)	-	-	0	0.1	-

Notes
 ~: Volume exceeds capacity \$: Delay exceeds 300s +: Computation Not Defined *: All major volume in platoon

4: Scottsdale Road & Acacia Driveway

06/15/2022

Intersection												
Int Delay, s/veh	0.4											
Movement	EBL	EBT	EBR	WBL	WBT	WBR	NBL	NBT	NBR	SBL	SBT	SBR
Lane Configurations		↕			↕		↕ ↑↑↑	↑↑↑	↕	↕ ↑↑↑		
Traffic Vol, veh/h	7	0	25	7	0	18	14	1108	5	8	1328	7
Future Vol, veh/h	7	0	25	7	0	18	14	1108	5	8	1328	7
Conflicting Peds, #/hr	0	0	0	0	0	0	0	0	0	0	0	0
Sign Control	Stop	Stop	Stop	Stop	Stop	Stop	Free	Free	Free	Free	Free	Free
RT Channelized	-	-	None	-	-	None	-	-	None	-	-	None
Storage Length	-	-	-	-	-	-	150	-	100	150	-	-
Veh in Median Storage, #	-	0	-	-	0	-	-	0	-	-	0	-
Grade, %	-	0	-	-	0	-	-	0	-	-	0	-
Peak Hour Factor	90	90	90	90	90	90	90	90	90	90	90	90
Heavy Vehicles, %	2	2	2	2	2	2	2	2	2	2	2	2
Mvmt Flow	8	0	28	8	0	20	16	1231	6	9	1476	8

Major/Minor	Minor2		Minor1		Major1			Major2				
Conflicting Flow All	2022	2767	742	1871	2765	616	1484	0	0	1237	0	0
Stage 1	1498	1498	-	1263	1263	-	-	-	-	-	-	-
Stage 2	524	1269	-	608	1502	-	-	-	-	-	-	-
Critical Hdwy	6.44	6.54	7.14	6.44	6.54	7.14	5.34	-	-	5.34	-	-
Critical Hdwy Stg 1	7.34	5.54	-	7.34	5.54	-	-	-	-	-	-	-
Critical Hdwy Stg 2	6.74	5.54	-	6.74	5.54	-	-	-	-	-	-	-
Follow-up Hdwy	3.82	4.02	3.92	3.82	4.02	3.92	3.12	-	-	3.12	-	-
Pot Cap-1 Maneuver	*232	*46	*610	*313	*46	*675	*767	-	-	792	-	-
Stage 1	*626	*595	-	*595	*597	-	-	-	-	-	-	-
Stage 2	*692	*592	-	*626	*595	-	-	-	-	-	-	-
Platoon blocked, %	1	1	1	1	1	1	1	-	-	1	-	-
Mov Cap-1 Maneuver	*219	*44	*610	*291	*45	*675	*767	-	-	792	-	-
Mov Cap-2 Maneuver	*219	*44	-	*291	*45	-	-	-	-	-	-	-
Stage 1	*613	*589	-	*583	*584	-	-	-	-	-	-	-
Stage 2	*658	*579	-	*591	*589	-	-	-	-	-	-	-

Approach	EB		WB		NB		SB	
HCM Control Delay, s	13.9		12.7		0.1		0.1	
HCM LOS	B		B					

Minor Lane/Major Mvmt	NBL	NBT	NBR	EBLn1	WBLn1	SBL	SBT	SBR
Capacity (veh/h)	*767	-	-	439	493	792	-	-
HCM Lane V/C Ratio	0.02	-	-	0.081	0.056	0.011	-	-
HCM Control Delay (s)	9.8	-	-	13.9	12.7	9.6	-	-
HCM Lane LOS	A	-	-	B	B	A	-	-
HCM 95th %tile Q(veh)	0.1	-	-	0.3	0.2	0	-	-

Notes
 ~: Volume exceeds capacity \$: Delay exceeds 300s +: Computation Not Defined *: All major volume in platoon

Intersection												
Int Delay, s/veh	3.9											
Movement	EBL	EBT	EBR	WBL	WBT	WBR	NBL	NBT	NBR	SBL	SBT	SBR
Lane Configurations	↖	↗		↖	↗			↕			↕	
Traffic Vol, veh/h	7	84	12	17	132	23	19	5	24	52	4	16
Future Vol, veh/h	7	84	12	17	132	23	19	5	24	52	4	16
Conflicting Peds, #/hr	0	0	0	0	0	0	0	0	0	0	0	0
Sign Control	Free	Free	Free	Free	Free	Free	Stop	Stop	Stop	Stop	Stop	Stop
RT Channelized	-	-	None	-	-	None	-	-	None	-	-	None
Storage Length	100	-	-	100	-	-	-	-	-	-	-	-
Veh in Median Storage, #	-	0	-	-	0	-	-	0	-	-	0	-
Grade, %	-	0	-	-	0	-	-	0	-	-	0	-
Peak Hour Factor	81	81	81	81	81	81	81	81	81	81	81	81
Heavy Vehicles, %	2	2	2	2	2	2	2	2	2	2	2	2
Mvmt Flow	9	104	15	21	163	28	23	6	30	64	5	20

Major/Minor	Major1			Major2			Minor1			Minor2		
Conflicting Flow All	191	0	0	119	0	0	362	363	112	367	356	177
Stage 1	-	-	-	-	-	-	130	130	-	219	219	-
Stage 2	-	-	-	-	-	-	232	233	-	148	137	-
Critical Hdwy	4.12	-	-	4.12	-	-	7.12	6.52	6.22	7.12	6.52	6.22
Critical Hdwy Stg 1	-	-	-	-	-	-	6.12	5.52	-	6.12	5.52	-
Critical Hdwy Stg 2	-	-	-	-	-	-	6.12	5.52	-	6.12	5.52	-
Follow-up Hdwy	2.218	-	-	2.218	-	-	3.518	4.018	3.318	3.518	4.018	3.318
Pot Cap-1 Maneuver	1383	-	-	1469	-	-	594	565	941	589	570	866
Stage 1	-	-	-	-	-	-	874	789	-	783	722	-
Stage 2	-	-	-	-	-	-	771	712	-	855	783	-
Platoon blocked, %	-	-	-	-	-	-	-	-	-	-	-	-
Mov Cap-1 Maneuver	1383	-	-	1469	-	-	567	553	941	557	558	866
Mov Cap-2 Maneuver	-	-	-	-	-	-	567	553	-	557	558	-
Stage 1	-	-	-	-	-	-	868	783	-	778	712	-
Stage 2	-	-	-	-	-	-	737	702	-	816	778	-

Approach	EB			WB			NB			SB		
HCM Control Delay, s	0.5			0.7			10.6			12		
HCM LOS							B			B		

Minor Lane/Major Mvmt	NBLn1	EBL	EBT	EBR	WBL	WBT	WBR	SBLn1
Capacity (veh/h)	705	1383	-	-	1469	-	-	605
HCM Lane V/C Ratio	0.084	0.006	-	-	0.014	-	-	0.147
HCM Control Delay (s)	10.6	7.6	-	-	7.5	-	-	12
HCM Lane LOS	B	A	-	-	A	-	-	B
HCM 95th %tile Q(veh)	0.3	0	-	-	0	-	-	0.5

2: Scottsdale Road & Gold Dust Avenue

06/15/2022



Movement	EBL	EBT	EBR	WBL	WBT	WBR	NBL	NBT	NBR	SBL	SBT	SBR
Lane Configurations	↘	↑	↗	↘	↕		↘	↕	↗	↘	↕	↗
Traffic Volume (veh/h)	54	61	74	75	67	46	101	1503	72	28	1250	36
Future Volume (veh/h)	54	61	74	75	67	46	101	1503	72	28	1250	36
Initial Q (Qb), veh	0	0	0	0	0	0	0	0	0	0	0	0
Ped-Bike Adj(A_pbT)	1.00		1.00	1.00		1.00	1.00		1.00	1.00		1.00
Parking Bus, Adj	1.00	1.00	1.00	1.00	1.00	1.00	1.00	1.00	1.00	1.00	1.00	1.00
Work Zone On Approach		No			No			No			No	
Adj Sat Flow, veh/h/ln	1870	1870	1870	1870	1870	1870	1870	1870	1870	1870	1870	1870
Adj Flow Rate, veh/h	58	66	80	81	72	46	109	1616	77	30	1344	39
Peak Hour Factor	0.93	0.93	0.93	0.93	0.93	1.00	0.93	0.93	0.93	0.93	0.93	0.93
Percent Heavy Veh, %	2	2	2	2	2	2	2	2	2	2	2	2
Cap, veh/h	165	216	183	163	249	147	864	1820	565	747	1512	44
Arrive On Green	0.12	0.12	0.12	0.12	0.12	0.12	0.45	0.36	0.36	0.39	0.30	0.30
Sat Flow, veh/h	1274	1870	1585	1242	2151	1268	1781	5106	1585	1781	5100	148
Grp Volume(v), veh/h	58	66	80	81	58	60	109	1616	77	30	897	486
Grp Sat Flow(s),veh/h/ln	1274	1870	1585	1242	1777	1642	1781	1702	1585	1781	1702	1844
Q Serve(g_s), s	5.3	3.9	5.6	7.7	3.6	4.0	0.0	35.8	3.9	0.0	30.2	30.2
Cycle Q Clear(g_c), s	9.2	3.9	5.6	11.6	3.6	4.0	0.0	35.8	3.9	0.0	30.2	30.2
Prop In Lane	1.00		1.00	1.00		0.77	1.00		1.00	1.00		0.08
Lane Grp Cap(c), veh/h	165	216	183	163	205	190	864	1820	565	747	1009	547
V/C Ratio(X)	0.35	0.31	0.44	0.50	0.28	0.31	0.13	0.89	0.14	0.04	0.89	0.89
Avail Cap(c_a), veh/h	247	337	285	243	320	296	864	3162	981	747	2108	1142
HCM Platoon Ratio	1.00	1.00	1.00	1.00	1.00	1.00	1.00	1.00	1.00	1.00	1.00	1.00
Upstream Filter(I)	1.00	1.00	1.00	1.00	1.00	1.00	1.00	1.00	1.00	1.00	1.00	1.00
Uniform Delay (d), s/veh	52.9	48.6	49.4	53.9	48.5	48.7	18.3	36.4	26.1	22.7	40.3	40.3
Incr Delay (d2), s/veh	0.5	0.3	0.6	0.9	0.3	0.3	0.0	6.9	0.5	0.0	11.6	19.1
Initial Q Delay(d3),s/veh	0.0	0.0	0.0	0.0	0.0	0.0	0.0	0.0	0.0	0.0	0.0	0.0
%ile BackOfQ(50%),veh/ln	1.7	1.8	2.3	2.4	1.6	1.6	1.7	15.5	1.5	0.5	13.9	16.2
Unsig. Movement Delay, s/veh												
LnGrp Delay(d),s/veh	53.4	48.9	50.0	54.8	48.8	49.0	18.3	43.2	26.6	22.7	51.9	59.4
LnGrp LOS	D	D	D	D	D	D	B	D	C	C	D	E
Approach Vol, veh/h		204			199			1802			1413	
Approach Delay, s/veh		50.6			51.3			41.0			53.9	
Approach LOS		D			D			D			D	
Timer - Assigned Phs	1	2		4	5	6		8				
Phs Duration (G+Y+Rc), s	59.5	41.3		19.3	52.3	48.5		19.3				
Change Period (Y+Rc), s	6.0	5.7		* 5.4	6.0	5.7		* 5.4				
Max Green Setting (Gmax), s	7.0	74.3		* 22	7.0	74.3		* 22				
Max Q Clear Time (g_c+I1), s	2.0	32.2		13.6	2.0	37.8		11.2				
Green Ext Time (p_c), s	0.0	3.4		0.3	0.0	5.0		0.3				

Intersection Summary

HCM 6th Ctrl Delay	47.2
HCM 6th LOS	D

Notes

User approved pedestrian interval to be less than phase max green.
 * HCM 6th computational engine requires equal clearance times for the phases crossing the barrier.

3: Scottsdale Road & Driveway B

06/15/2022

Intersection												
Int Delay, s/veh	0.1											
Movement	EBL	EBT	EBR	WBL	WBT	WBR	NBL	NBT	NBR	SBL	SBT	SBR
Lane Configurations			↗			↗	↑↑↑			↑↑↑		
Traffic Vol, veh/h	0	0	17	0	0	15	0	1659	1	0	1372	26
Future Vol, veh/h	0	0	17	0	0	15	0	1659	1	0	1372	26
Conflicting Peds, #/hr	0	0	0	0	0	0	0	0	0	0	0	0
Sign Control	Stop	Stop	Stop	Stop	Stop	Stop	Free	Free	Free	Free	Free	Free
RT Channelized	-	-	None	-	-	None	-	-	None	-	-	None
Storage Length	-	-	0	-	-	0	-	-	-	-	-	-
Veh in Median Storage, #	-	0	-	-	0	-	-	0	-	-	0	-
Grade, %	-	0	-	-	0	-	-	0	-	-	0	-
Peak Hour Factor	93	93	93	93	93	93	93	93	93	93	93	93
Heavy Vehicles, %	2	2	2	2	2	2	2	2	2	2	2	2
Mvmt Flow	0	0	18	0	0	16	0	1784	1	0	1475	28

Major/Minor	Minor2		Minor1		Major1		Major2	
Conflicting Flow All	-	-	752	-	-	893	-	0
Stage 1	-	-	-	-	-	-	-	-
Stage 2	-	-	-	-	-	-	-	-
Critical Hdwy	-	-	7.14	-	-	7.14	-	-
Critical Hdwy Stg 1	-	-	-	-	-	-	-	-
Critical Hdwy Stg 2	-	-	-	-	-	-	-	-
Follow-up Hdwy	-	-	3.92	-	-	3.92	-	-
Pot Cap-1 Maneuver	0	0	*610	0	0	*545	0	-
Stage 1	0	0	-	0	0	-	0	-
Stage 2	0	0	-	0	0	-	0	-
Platoon blocked, %			1			1		
Mov Cap-1 Maneuver	-	-	*610	-	-	*545	-	-
Mov Cap-2 Maneuver	-	-	-	-	-	-	-	-
Stage 1	-	-	-	-	-	-	-	-
Stage 2	-	-	-	-	-	-	-	-

Approach	EB		WB		NB		SB	
HCM Control Delay, s	11.1		11.8		0		0	
HCM LOS	B		B					

Minor Lane/Major Mvmt	NBT	NBR	EBLn1WBLn1	SBT	SBR
Capacity (veh/h)	-	-	610	545	-
HCM Lane V/C Ratio	-	-	0.03	0.03	-
HCM Control Delay (s)	-	-	11.1	11.8	-
HCM Lane LOS	-	-	B	B	-
HCM 95th %tile Q(veh)	-	-	0.1	0.1	-

Notes
 ~: Volume exceeds capacity \$: Delay exceeds 300s +: Computation Not Defined *: All major volume in platoon

4: Scottsdale Road & Acacia Driveway

06/15/2022

Intersection												
Int Delay, s/veh	0.5											
Movement	EBL	EBT	EBR	WBL	WBT	WBR	NBL	NBT	NBR	SBL	SBT	SBR
Lane Configurations		↕			↕		↕ ↑↑↑	↑↑↑	↕	↕ ↑↑↑		
Traffic Vol, veh/h	6	1	33	3	1	10	48	1641	6	22	1386	19
Future Vol, veh/h	6	1	33	3	1	10	48	1641	6	22	1386	19
Conflicting Peds, #/hr	0	0	0	0	0	0	0	0	0	0	0	0
Sign Control	Stop	Stop	Stop	Stop	Stop	Stop	Free	Free	Free	Free	Free	Free
RT Channelized	-	-	None	-	-	None	-	-	None	-	-	None
Storage Length	-	-	-	-	-	-	150	-	100	150	-	-
Veh in Median Storage, #	-	0	-	-	0	-	-	0	-	-	0	-
Grade, %	-	0	-	-	0	-	-	0	-	-	0	-
Peak Hour Factor	94	94	94	94	94	94	94	94	94	94	94	94
Heavy Vehicles, %	2	2	2	2	2	2	2	2	2	2	2	2
Mvmt Flow	6	1	35	3	1	11	51	1746	6	23	1474	20

Major/Minor	Minor2		Minor1		Major1		Major2					
Conflicting Flow All	2331	3384	747	2484	3388	873	1494	0	0	1752	0	0
Stage 1	1530	1530	-	1848	1848	-	-	-	-	-	-	-
Stage 2	801	1854	-	636	1540	-	-	-	-	-	-	-
Critical Hdwy	6.44	6.54	7.14	6.44	6.54	7.14	5.34	-	-	5.34	-	-
Critical Hdwy Stg 1	7.34	5.54	-	7.34	5.54	-	-	-	-	-	-	-
Critical Hdwy Stg 2	6.74	5.54	-	6.74	5.54	-	-	-	-	-	-	-
Follow-up Hdwy	3.82	4.02	3.92	3.82	4.02	3.92	3.12	-	-	3.12	-	-
Pot Cap-1 Maneuver	*244	180	*610	*244	176	*545	*767	-	-	*686	-	-
Stage 1	*595	575	-	*528	512	-	-	-	-	-	-	-
Stage 2	*560	507	-	*626	567	-	-	-	-	-	-	-
Platoon blocked, %	1	1	1	1	1	1	1	-	-	1	-	-
Mov Cap-1 Maneuver	*221	162	*610	*212	159	*545	*767	-	-	*686	-	-
Mov Cap-2 Maneuver	*221	162	-	*212	159	-	-	-	-	-	-	-
Stage 1	*555	556	-	*493	478	-	-	-	-	-	-	-
Stage 2	*511	474	-	*569	547	-	-	-	-	-	-	-

Approach	EB		WB		NB		SB	
HCM Control Delay, s	13.7		15.4		0.3		0.2	
HCM LOS	B		C					

Minor Lane/Major Mvmt	NBL	NBT	NBR	EBLn1	WBLn1	SBL	SBT	SBR
Capacity (veh/h)	* 767	-	-	458	361	* 686	-	-
HCM Lane V/C Ratio	0.067	-	-	0.093	0.041	0.034	-	-
HCM Control Delay (s)	10	-	-	13.7	15.4	10.4	-	-
HCM Lane LOS	B	-	-	B	C	B	-	-
HCM 95th %tile Q(veh)	0.2	-	-	0.3	0.1	0.1	-	-

Notes
 ~: Volume exceeds capacity \$: Delay exceeds 300s +: Computation Not Defined *: All major volume in platoon



Appendix G – Trip Generation



Proposed Development

220 Multifamily Housing (Low-Rise)																							
Land Use	ITE Code	Qty	Unit	Weekday			AM Peak Hour			PM Peak Hour			Weekday			AM Peak Hour			PM Peak Hour				
				Rate	% In	% Out	Rate	% In	% Out	Rate	% In	% Out	Total	In	Out	Total	In	Out	Total	In	Out		
Multifamily Housing (Low-Rise)	220	212	Dwelling Units	6.74	50%	50%	0.40	24%	76%	0.51	63%	37%	1,429	715	714	85	20	65	108	68	40	Average	
Multifamily Housing (Low-Rise)	220	212	Dwelling Units	2.46	50%	50%	0.13	24%	76%	0.08	63%	37%	522	261	261	28	7	21	17	11	6	Minimum	
Multifamily Housing (Low-Rise)	220	212	Dwelling Units	12.50	50%	50%	0.73	24%	76%	1.04	63%	37%	2,650	1,325	1,325	155	37	118	220	139	81	Maximum	
Land Use	ITE Code	Qty	Unit	Weekday			AM Peak Hour			PM Peak Hour			Weekday			AM Peak Hour			PM Peak Hour				
Multifamily Housing (Low-Rise)	220	212	Dwelling Units	Equation			Equation			Equation			Total	In	Out	Total	In	Out	Total	In	Out	Equation	
Multifamily Housing (Low-Rise)	220	212	Dwelling Units	T=6.41(X)+75.31			T=0.31(X)+22.85			T=0.43(X)+20.55			1,434	717	717	89	21	68	112	71	41		Equation

Multifamily Housing (Low-Rise)	Standard Deviation	1.79		0.12		0.15	
	Number of Studies	22		49		59	
	Average Size	229		249		241	
	R ²	0.86		0.79		0.84	

492 Health/Fitness Club																						
Land Use	ITE Code	Qty	Unit	Weekday*			AM Peak Hour			PM Peak Hour			Weekday			AM Peak Hour			PM Peak Hour			
				Rate	% In	% Out	Rate	% In	% Out	Rate	% In	% Out	Total	In	Out	Total	In	Out	Total	In	Out	
Health/Fitness Club	492	2.5	1000 SF GFA	28.82	50%	50%	1.31	51%	49%	3.45	57%	43%	72	36	36	3	2	1	9	5	4	Average
Health/Fitness Club	492	2.5	1000 SF GFA	21.49	50%	50%	0.3	51%	49%	1.48	57%	43%	54	27	27	1	1	0	4	2	2	Minimum
Health/Fitness Club	492	2.5	1000 SF GFA	36.71	50%	50%	2	51%	49%	8.37	57%	43%	92	46	46	5	3	2	21	12	9	Maximum
Land Use	ITE Code	Qty	Unit	Weekday*			AM Peak Hour			PM Peak Hour			Weekday			AM Peak Hour			PM Peak Hour			
Health/Fitness Club	492	2.5	1000 SF GFA	Equation			Equation			Equation			Total	In	Out	Total	In	Out	Total	In	Out	Equation
Health/Fitness Club	492	2.5	1000 SF GFA	Ln(T)=0.98Ln(X)+3.42			N/A			Ln(T)=0.67Ln(X)+2.44			75	38	37	N/A	N/A	N/A	21	12	9	

Health/Fitness Club	Standard Deviation	8.56*		0.64		1.57	
	Number of Studies	4*		6		8	
	Average Size	78*		44		37	
	R ²	0.74*		N/A		0.67	

*Land Use 495 Recreational Community Center Data Used for Weekday Calculations



Gold Dust

Completed: GT 3/19/2022
Checked: TC 3/19/2022

Trip Generation Calculations, 11th Edition

Adjacent Land Uses

220 Multifamily Housing (Low-Rise) (One to Three Levels)																						
Land Use	ITE Code	Qty	Unit	Weekday			AM Peak Hour			PM Peak Hour			Weekday			AM Peak Hour			PM Peak Hour			Average
				Rate	% In	% Out	Rate	% In	% Out	Rate	% In	% Out	Total	In	Out	Total	In	Out	Total	In	Out	
Multifamily Housing (Low-Rise)	220	304	Dwelling Units	6.74	50%	50%	0.40	24%	76%	0.51	63%	37%	2,049	1,025	1,024	122	29	93	155	98	57	Average
Multifamily Housing (Low-Rise)	220	304	Dwelling Units	2.46	50%	50%	0.13	24%	76%	0.08	63%	37%	748	374	374	40	10	30	24	15	9	Minimum
Multifamily Housing (Low-Rise)	220	304	Dwelling Units	12.50	50%	50%	0.73	24%	76%	1.04	63%	37%	3,800	1,900	1,900	222	53	169	316	199	117	Maximum
Land Use	ITE Code	Qty	Unit	Weekday			AM Peak Hour			PM Peak Hour			Weekday			AM Peak Hour			PM Peak Hour			Equation
Multifamily Housing (Low-Rise)	220	304	Dwelling Units	T=6.41(X)+75.31			T=0.31(X)+22.85			T=0.43(X)+20.55			Total	In	Out	Total	In	Out	Total	In	Out	
				50%	50%		24%	76%		63%	37%	2,024	1,012	1,012	117	28	89	151	95	56		
Multifamily Housing (Low-Rise)				Standard Deviation	1.79			0.12			0.15											
				Number of Studies	22			49			59											
				Average Size	229			249			241											
				R ²	0.86			0.79			0.84											

220 Multifamily Housing (Low-Rise) (One to Three Levels)																						
Land Use	ITE Code	Qty	Unit	Weekday			AM Peak Hour			PM Peak Hour			Weekday			AM Peak Hour			PM Peak Hour			Average
				Rate	% In	% Out	Rate	% In	% Out	Rate	% In	% Out	Total	In	Out	Total	In	Out	Total	In	Out	
Multifamily Housing (Low-Rise)	220	108	Dwelling Units	6.74	50%	50%	0.40	24%	76%	0.51	63%	37%	728	364	364	43	10	33	55	35	20	Average
Multifamily Housing (Low-Rise)	220	108	Dwelling Units	2.46	50%	50%	0.13	24%	76%	0.08	63%	37%	266	133	133	14	3	11	9	6	3	Minimum
Multifamily Housing (Low-Rise)	220	108	Dwelling Units	12.50	50%	50%	0.73	24%	76%	1.04	63%	37%	1,350	675	675	79	19	60	112	71	41	Maximum
Land Use	ITE Code	Qty	Unit	Weekday			AM Peak Hour			PM Peak Hour			Weekday			AM Peak Hour			PM Peak Hour			Equation
Multifamily Housing (Low-Rise)	220	108	Dwelling Units	T=6.41(X)+75.31			T=0.31(X)+22.85			T=0.43(X)+20.55			Total	In	Out	Total	In	Out	Total	In	Out	
				50%	50%		24%	76%		63%	37%	768	384	384	56	13	43	67	42	25		
Multifamily Housing (Low-Rise)				Standard Deviation	1.79			0.12			0.15											
				Number of Studies	22			49			59											
				Average Size	229			249			241											
				R ²	0.86			0.79			0.84											

932 High-Turnover (Sit-Down) Restaurant																						
Land Use	ITE Code	Qty	Unit	Weekday			AM Peak Hour			PM Peak Hour			Weekday			AM Peak Hour			PM Peak Hour			Average
				Rate	% In	% Out	Rate	% In	% Out	Rate	% In	% Out	Total	In	Out	Total	In	Out	Total	In	Out	
High-Turnover (Sit-Down) Restaurant	932	5,160	1000 SF GFA	107.20	50%	50%	9.57	55%	45%	9.05	61%	39%	553	277	276	49	27	22	47	29	18	Average
High-Turnover (Sit-Down) Restaurant	932	5,160	1000 SF GFA	13.04	50%	50%	0.76	55%	45%	0.92	61%	39%	67	34	33	4	2	2	5	3	2	Minimum
High-Turnover (Sit-Down) Restaurant	932	5,160	1000 SF GFA	742.41	50%	50%	102.39	55%	45%	62.00	61%	39%	3,831	1,916	1,915	528	290	238	320	195	125	Maximum
Land Use	ITE Code	Qty	Unit	Weekday			AM Peak Hour			PM Peak Hour			Weekday			AM Peak Hour			PM Peak Hour			Equation
High-Turnover (Sit-Down) Restaurant	932	5,160	1000 SF GFA	N/A			N/A			N/A			Total	In	Out	Total	In	Out	Total	In	Out	
				N/A	N/A	N/A	N/A	N/A	N/A	N/A	N/A	N/A	N/A	N/A	N/A	N/A	N/A	N/A	N/A	N/A	N/A	
High-Turnover (Sit-Down) Restaurant				Standard Deviation	66.72			11.61			6.18											
				Number of Studies	50			37			104											
				Average Size	5			5			6											
				R ²	N/A			N/A			N/A											

881 Pharmacy/Drugstore with Drive-Thru																						
Land Use	ITE Code	Qty	Unit	Weekday			AM Peak Hour			PM Peak Hour			Weekday			AM Peak Hour			PM Peak Hour			Average
				Rate	% In	% Out	Rate	% In	% Out	Rate	% In	% Out	Total	In	Out	Total	In	Out	Total	In	Out	
Pharmacy/Drugstore with Drive-Thru	881	14,391	1000 SF GFA	108.40	50%	50%	3.74	52%	48%	10.25	50%	50%	1,560	780	780	54	28	26	148	74	74	Average
Pharmacy/Drugstore with Drive-Thru	881	14,391	1000 SF GFA	65.05	50%	50%	1.93	52%	48%	4.86	50%	50%	936	468	468	28	15	13	70	35	35	Minimum



Appendix H – MAG Socioeconomic Projections

Socioeconomic Projections

Population and Employment

by Municipal Planning Area, Jurisdiction, and Regional Analysis Zone

June 2019



302 North 1st Avenue, Suite 300
Phoenix, Arizona 85003
(602) 254-6300

Maricopa Association of Governments

**Table 1: Total Population by Municipal Planning Area
July 1, 2018 and Projections July 1, 2020 to July 1, 2055**

Municipal Planning Area	Total Population					
	2018	2020	2030	2040	2050	2055
Apache Junction	59,000	60,800	70,000	92,000	117,100	132,600
Avondale	84,200	86,700	101,800	111,900	119,000	122,100
Buckeye	89,000	97,700	186,600	305,400	409,900	459,300
Carefree	3,700	3,800	4,100	4,200	4,200	4,300
Cave Creek	5,900	6,000	6,500	7,000	7,200	7,300
Chandler	270,300	279,500	309,100	321,100	329,000	332,400
El Mirage	34,300	35,100	36,500	36,900	37,200	37,200
Florence	79,400	85,500	120,300	160,500	209,900	231,400
Fort McDowell Yavapai Native Nation	1,000	1,100	1,100	1,100	1,100	1,100
Fountain Hills	24,000	24,700	26,200	26,600	26,900	27,000
Gila Bend	2,500	2,700	3,700	3,700	3,900	4,200
Gila River Indian Native Nation	12,000	12,200	12,300	12,300	12,300	12,300
Gilbert	256,500	265,900	293,500	308,800	318,100	321,400
Glendale	272,200	279,100	306,400	323,400	333,200	338,800
Goodyear	87,300	92,100	140,300	192,200	228,600	247,900
Guadalupe	6,300	6,400	6,700	6,800	6,800	6,800
Litchfield Park	13,300	14,000	15,400	15,700	16,100	16,400
Maricopa	59,800	67,000	90,800	106,400	121,600	128,900
Mesa	533,400	552,800	607,500	649,400	680,000	690,300
Paradise Valley	14,000	14,100	14,700	15,100	15,200	15,300
Peoria	188,500	196,600	232,400	273,700	312,600	329,900
Phoenix	1,653,500	1,697,700	1,881,900	2,019,300	2,117,400	2,155,300
Queen Creek	58,700	65,000	90,900	109,000	120,900	128,500
Salt River Pima-Maricopa Native Nation	6,800	6,100	5,700	5,800	5,800	5,800
Scottsdale	245,500	253,800	281,900	299,400	311,400	316,700
Surprise	144,000	150,300	216,700	307,500	383,300	417,200
Tempe	185,300	190,000	217,100	247,000	272,400	282,200
Tolleson	7,000	7,100	8,600	10,300	11,400	11,800
Unincorporated Pinal County	66,800	68,600	79,100	93,700	110,800	122,700
Unincorporated Maricopa County	97,900	101,200	110,500	116,800	137,000	152,600
Wickenburg	8,200	8,500	9,400	9,500	9,800	10,000
Youngtown	6,600	6,800	7,300	7,700	7,800	7,800

Notes: Numbers rounded to the nearest 100. These projections include both the Maricopa County and Pinal County portions for Apache Junction, Queen Creek, and the Gila River Indian Community. Peoria and Wickenburg include only the Maricopa County portion.

Source: Maricopa Association of Governments (MAG) Socioeconomic Projections of Population and Employment by Municipal Planning Area (MPA) and Regional Analysis Zone (RAZ), June 2019

For explanation of variables and complete notation on this series, please refer to the Notes and Caveats in Appendix A.

Maricopa Association of Governments
Table 2: Total Employment by Municipal Planning Area
July 1, 2018 and Projections July 1, 2020 to July 1, 2055

Municipal Planning Area	Total Employment					
	2018	2020	2030	2040	2050	2055
Apache Junction	7,800	8,800	13,100	17,800	26,400	30,500
Avondale	22,400	23,200	30,400	36,200	42,800	45,400
Buckeye	21,600	26,900	42,900	64,500	98,000	128,900
Carefree	1,600	1,600	2,100	2,400	2,500	2,600
Cave Creek	2,200	2,400	2,700	2,900	3,000	3,200
Chandler	145,500	154,700	182,300	202,100	215,200	222,000
El Mirage	5,000	5,100	6,500	7,200	8,000	8,900
Florence	11,000	12,100	17,000	26,400	40,900	51,100
Fort McDowell Yavapai Native Nation	2,200	2,400	2,400	2,500	2,600	2,600
Fountain Hills	7,100	7,700	9,100	9,800	10,200	10,300
Gila Bend	900	900	1,200	1,300	1,500	1,700
Gila River Indian Native Nation	10,500	10,700	11,500	13,100	14,800	15,500
Gilbert	92,800	98,600	120,200	135,900	146,600	152,200
Glendale	103,800	111,400	134,000	153,100	168,900	175,900
Goodyear	35,900	37,200	50,600	69,000	92,600	102,500
Guadalupe	1,300	1,300	1,500	1,600	1,600	1,600
Litchfield Park	3,800	4,400	5,200	5,900	6,400	6,700
Maricopa	6,200	7,100	11,400	18,200	28,200	33,500
Mesa	197,200	205,900	249,000	296,000	333,700	351,000
Paradise Valley	6,300	6,300	6,800	7,100	7,500	7,700
Peoria	58,200	62,400	73,100	84,800	91,900	96,300
Phoenix	897,700	937,600	1,084,000	1,189,200	1,264,900	1,298,900
Queen Creek	15,500	16,400	19,900	24,000	28,900	31,100
Salt River Pima-Maricopa Native Nation	21,200	22,900	28,200	33,900	35,900	36,400
Scottsdale	197,200	207,400	235,500	252,000	261,700	267,000
Surprise	33,600	36,400	59,500	86,400	113,400	130,500
Tempe	190,000	200,500	231,200	257,700	280,000	290,900
Tolleson	17,700	18,300	21,200	23,900	26,000	26,700
Unincorporated Pinal County	3,500	3,900	6,000	8,900	13,500	17,800
Unincorporated Maricopa County	28,600	31,500	35,500	41,100	51,200	58,400
Wickenburg	4,400	4,600	5,200	5,600	6,000	6,200
Youngtown	1,500	1,800	2,200	2,700	2,800	3,100

Notes: Numbers rounded to the nearest 100. These projections include both the Maricopa County and Pinal County portions for Apache Junction, Queen Creek, and the Gila River Indian Community. Peoria and Wickenburg include only the Maricopa County portion.

Source: Maricopa Association of Governments (MAG) Socioeconomic Projections of Population and Employment by Municipal Planning Area (MPA) and Regional Analysis Zone (RAZ), June 2019

For explanation of variables and complete notation on this series, please refer to the Notes and Caveats in Appendix A.

Regional Analysis Zones (RAZ), 2019
Maricopa and Pinal Counties, Arizona

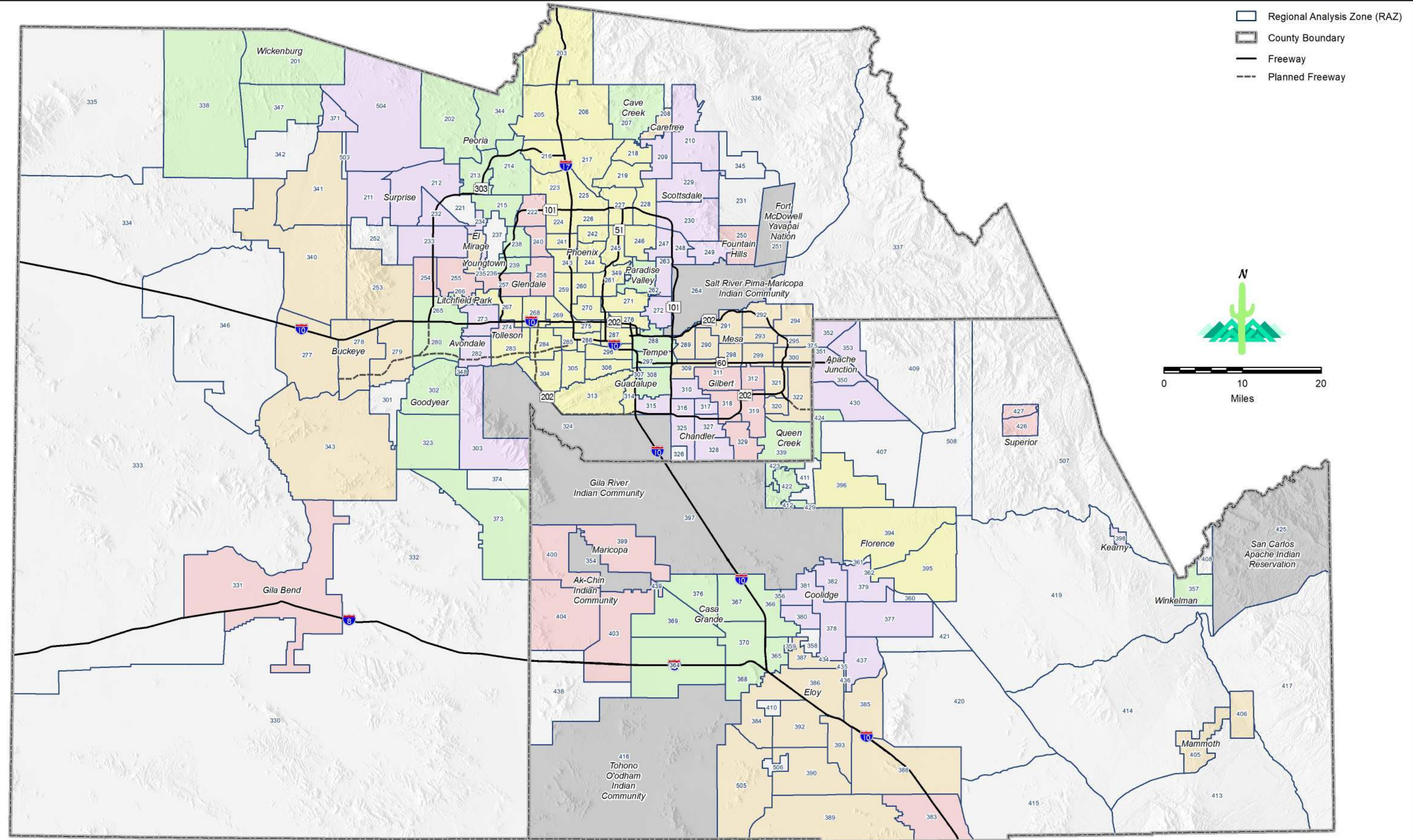

Maricopa Association of Governments
Table 4: Population by Regional Analysis Zone (RAZ) by MPA
July 1, 2018 and Projections July 1, 2020 to July 1, 2055

RAZ	County	Total Population					
		2018	2020	2030	2040	2050	2055
	Total	1,653,469	1,697,722	1,881,876	2,019,269	2,117,427	2,155,333
Queen Creek MPA							
339	Maricopa County	49,781	53,579	72,670	82,172	87,155	89,586
422	Pinal County	13	13	300	437	564	638
423	Pinal County	1,286	1,410	3,714	6,136	7,457	8,686
424	Pinal County	7,642	10,003	14,200	20,287	25,759	29,586
	Total	58,722	65,005	90,884	109,032	120,935	128,496
Salt River Pima-Maricopa Native Nation MPA							
264	Maricopa County	6,798	6,073	5,708	5,820	5,820	5,820
	Total	6,798	6,073	5,708	5,820	5,820	5,820
Scottsdale MPA							
209	Maricopa County	12,188	12,605	13,961	14,512	14,984	15,255
210	Maricopa County	6,013	6,591	10,463	12,339	13,491	13,961
229	Maricopa County	20,542	21,269	25,221	27,864	29,698	30,229
230	Maricopa County	32,232	33,028	38,882	43,580	46,789	48,510
247	Maricopa County	13,549	13,858	15,420	16,342	16,871	17,019
248	Maricopa County	36,178	37,227	38,468	38,807	39,048	39,143
249	Maricopa County	20,903	21,410	22,543	22,768	22,839	22,848
263	Maricopa County	34,908	35,814	37,002	37,252	37,584	37,773
272	Maricopa County	68,987	71,970	79,910	85,942	90,054	91,927
	Total	245,500	253,772	281,870	299,406	311,358	316,665
Surprise MPA							
211	Maricopa County	863	884	4,471	23,112	36,704	40,737
212	Maricopa County	10,265	11,365	37,615	69,296	85,862	93,806
232	Maricopa County	29,296	30,200	34,506	37,144	37,927	38,313
233	Maricopa County	87,834	91,276	111,822	119,384	123,777	126,523
234	Maricopa County	8,969	9,467	10,460	10,878	11,335	11,488
371	Maricopa County	342	344	434	734	2,584	4,316
504	Maricopa County	6,460	6,718	17,425	46,912	85,127	102,004
	Total	144,029	150,254	216,733	307,460	383,316	417,187
Tempe MPA							
288	Maricopa County	73,442	76,444	100,651	129,202	150,094	157,410
297	Maricopa County	53,146	54,092	56,336	57,432	61,780	64,273
308	Maricopa County	58,756	59,473	60,120	60,348	60,476	60,559
	Total	185,344	190,009	217,107	246,982	272,350	282,242

Notes: Numbers rounded to the nearest 100. These projections include both the Maricopa County and Pinal County portions for Apache Junction, Queen Creek, and the Gila River Indian Community. Peoria and Wickenburg include only the Maricopa County portion.

Source: Maricopa Association of Governments (MAG) Socioeconomic Projections of Population and Employment by Municipal Planning Area (MPA) and Regional Analysis Zone (RAZ), May 2019

For explanation of variables and complete notation on this series, please refer to the Notes and Caveats in Appendix A.

Maricopa Association of Governments
Table 5: Employment by Regional Analysis Zone (RAZ) by MPA
July 1, 2018 and Projections July 1, 2020 to July 1, 2055

RAZ	County	Total Employment					
		2018	2020	2030	2040	2050	2055
Total		897,713	937,622	1,083,980	1,189,209	1,264,941	1,298,903
Queen Creek MPA							
339	Maricopa County	13,933	14,696	16,482	18,825	20,733	21,151
422	Pinal County	9	8	18	22	31	39
423	Pinal County	89	109	351	620	1,068	1,639
424	Pinal County	1,435	1,576	3,073	4,571	7,020	8,309
Total		15,466	16,389	19,924	24,038	28,852	31,138
Salt River Pima-Maricopa Native Nation MPA							
264	Maricopa County	21,160	22,869	28,215	33,871	35,903	36,442
Total		21,160	22,869	28,215	33,871	35,903	36,442
Scottsdale MPA							
209	Maricopa County	4,488	4,659	4,851	5,174	5,161	5,344
210	Maricopa County	2,386	3,018	2,759	3,091	3,139	3,191
229	Maricopa County	9,604	10,005	11,231	11,962	12,193	12,896
230	Maricopa County	23,272	24,919	32,112	36,968	40,834	42,136
247	Maricopa County	44,254	47,089	52,652	54,822	55,679	56,105
248	Maricopa County	29,603	30,901	33,285	34,001	34,234	34,548
249	Maricopa County	7,409	7,692	8,179	8,684	8,906	9,045
263	Maricopa County	26,351	26,961	28,903	30,245	30,919	31,381
272	Maricopa County	49,833	52,185	61,540	67,039	70,676	72,330
Total		197,200	207,429	235,512	251,986	261,741	266,976
Surprise MPA							
211	Maricopa County	60	53	1,560	3,172	4,766	7,017
212	Maricopa County	2,008	2,338	5,821	9,965	13,362	15,709
232	Maricopa County	8,349	9,228	11,297	12,187	12,875	13,116
233	Maricopa County	19,943	21,079	32,661	44,032	52,007	57,402
234	Maricopa County	2,588	2,711	3,354	3,922	4,239	4,386
371	Maricopa County	18	20	327	423	2,381	2,937
504	Maricopa County	677	1,020	4,460	12,695	23,763	29,886
Total		33,643	36,449	59,480	86,396	113,393	130,453
Tempe MPA							
288	Maricopa County	88,927	94,229	111,010	128,894	144,714	152,703
297	Maricopa County	44,730	47,069	53,149	57,125	60,725	62,552
308	Maricopa County	56,380	59,208	67,052	71,701	74,542	75,596
Total		190,037	200,506	231,211	257,720	279,981	290,851

Notes: Numbers rounded to the nearest 100. These projections include both the Maricopa County and Pinal County portions for Apache Junction, Queen Creek, and the Gila River Indian Community. Peoria and Wickenburg include only the Maricopa County portion.

Source: Maricopa Association of Governments (MAG) Socioeconomic Projections of Population and Employment by Municipal Planning Area (MPA) and Regional Analysis Zone (RAZ), May 2019

For explanation of variables and complete notation on this series, please refer to the Notes and Caveats in Appendix A.



Appendix I – Year 2025 No Build Capacity Analysis

Intersection												
Int Delay, s/veh	1.6											
Movement	EBL	EBT	EBR	WBL	WBT	WBR	NBL	NBT	NBR	SBL	SBT	SBR
Lane Configurations												
Traffic Vol, veh/h	6	147	6	13	207	16	9	2	15	15	2	10
Future Vol, veh/h	6	147	6	13	207	16	9	2	15	15	2	10
Conflicting Peds, #/hr	0	0	0	0	0	0	0	0	0	0	0	0
Sign Control	Free	Free	Free	Free	Free	Free	Stop	Stop	Stop	Stop	Stop	Stop
RT Channelized	-	-	None	-	-	None	-	-	None	-	-	None
Storage Length	100	-	-	100	-	-	-	-	-	-	-	-
Veh in Median Storage, #	-	0	-	-	0	-	-	0	-	-	0	-
Grade, %	-	0	-	-	0	-	-	0	-	-	0	-
Peak Hour Factor	92	92	92	92	92	92	92	92	92	92	92	92
Heavy Vehicles, %	2	2	2	2	2	2	2	2	2	2	2	2
Mvmt Flow	7	160	7	14	225	17	10	2	16	16	2	11

Major/Minor	Major1			Major2			Minor1			Minor2		
Conflicting Flow All	242	0	0	167	0	0	446	448	164	449	443	234
Stage 1	-	-	-	-	-	-	178	178	-	262	262	-
Stage 2	-	-	-	-	-	-	268	270	-	187	181	-
Critical Hdwy	4.12	-	-	4.12	-	-	7.12	6.52	6.22	7.12	6.52	6.22
Critical Hdwy Stg 1	-	-	-	-	-	-	6.12	5.52	-	6.12	5.52	-
Critical Hdwy Stg 2	-	-	-	-	-	-	6.12	5.52	-	6.12	5.52	-
Follow-up Hdwy	2.218	-	-	2.218	-	-	3.518	4.018	3.318	3.518	4.018	3.318
Pot Cap-1 Maneuver	1324	-	-	1411	-	-	523	506	881	520	509	805
Stage 1	-	-	-	-	-	-	824	752	-	743	691	-
Stage 2	-	-	-	-	-	-	738	686	-	815	750	-
Platoon blocked, %	-	-	-	-	-	-	-	-	-	-	-	-
Mov Cap-1 Maneuver	1324	-	-	1411	-	-	508	498	881	503	501	805
Mov Cap-2 Maneuver	-	-	-	-	-	-	508	498	-	503	501	-
Stage 1	-	-	-	-	-	-	820	748	-	739	684	-
Stage 2	-	-	-	-	-	-	719	679	-	793	746	-

Approach	EB			WB			NB			SB		
HCM Control Delay, s	0.3			0.4			10.6			11.5		
HCM LOS							B			B		

Minor Lane/Major Mvmt	NBLn1	EBL	EBT	EBR	WBL	WBT	WBR	SBLn1
Capacity (veh/h)	671	1324	-	-	1411	-	-	584
HCM Lane V/C Ratio	0.042	0.005	-	-	0.01	-	-	0.05
HCM Control Delay (s)	10.6	7.7	-	-	7.6	-	-	11.5
HCM Lane LOS	B	A	-	-	A	-	-	B
HCM 95th %tile Q(veh)	0.1	0	-	-	0	-	-	0.2

2: Scottsdale Road & Gold Dust Avenue

06/15/2022



Movement	EBL	EBT	EBR	WBL	WBT	WBR	NBL	NBT	NBR	SBL	SBT	SBR
Lane Configurations	↘	↑	↗	↘	↕		↘	↕	↗	↘	↕	↗
Traffic Volume (veh/h)	86	91	136	59	109	40	94	935	107	29	1212	80
Future Volume (veh/h)	86	91	136	59	109	40	94	935	107	29	1212	80
Initial Q (Qb), veh	0	0	0	0	0	0	0	0	0	0	0	0
Ped-Bike Adj(A_pbT)	1.00		1.00	1.00		1.00	1.00		1.00	1.00		1.00
Parking Bus, Adj	1.00	1.00	1.00	1.00	1.00	1.00	1.00	1.00	1.00	1.00	1.00	1.00
Work Zone On Approach		No			No			No			No	
Adj Sat Flow, veh/h/ln	1870	1870	1870	1870	1870	1870	1870	1870	1870	1870	1870	1870
Adj Flow Rate, veh/h	93	99	148	64	118	43	102	1016	116	32	1317	87
Peak Hour Factor	0.92	0.92	0.92	0.92	0.92	0.92	0.92	0.92	0.92	0.92	0.92	0.92
Percent Heavy Veh, %	2	2	2	2	2	2	2	2	2	2	2	2
Cap, veh/h	176	257	218	161	355	124	804	1137	353	957	1480	98
Arrive On Green	0.14	0.14	0.14	0.14	0.14	0.14	0.83	0.45	0.45	0.50	0.30	0.30
Sat Flow, veh/h	1225	1870	1585	1133	2583	902	1781	5106	1585	1781	4893	323
Grp Volume(v), veh/h	93	99	148	64	80	81	102	1016	116	32	916	488
Grp Sat Flow(s),veh/h/ln	1225	1870	1585	1133	1777	1708	1781	1702	1585	1781	1702	1812
Q Serve(g_s), s	8.9	5.8	10.7	6.5	4.9	5.2	0.0	22.0	5.7	0.0	30.8	30.8
Cycle Q Clear(g_c), s	14.1	5.8	10.7	12.3	4.9	5.2	0.0	22.0	5.7	0.0	30.8	30.8
Prop In Lane	1.00		1.00	1.00		0.53	1.00		1.00	1.00		0.18
Lane Grp Cap(c), veh/h	176	257	218	161	245	235	804	1137	353	957	1030	548
V/C Ratio(X)	0.53	0.38	0.68	0.40	0.33	0.35	0.13	0.89	0.33	0.03	0.89	0.89
Avail Cap(c_a), veh/h	228	337	285	209	320	307	804	3162	981	957	2108	1122
HCM Platoon Ratio	1.00	1.00	1.00	1.00	1.00	1.00	2.00	2.00	2.00	1.00	1.00	1.00
Upstream Filter(I)	1.00	1.00	1.00	1.00	1.00	1.00	1.00	1.00	1.00	1.00	1.00	1.00
Uniform Delay (d), s/veh	53.2	47.1	49.2	52.7	46.7	46.9	5.8	32.0	27.5	14.7	39.9	39.9
Incr Delay (d2), s/veh	0.9	0.4	2.0	0.6	0.3	0.3	0.0	10.9	2.5	0.0	11.5	19.2
Initial Q Delay(d3),s/veh	0.0	0.0	0.0	0.0	0.0	0.0	0.0	0.0	0.0	0.0	0.0	0.0
%ile BackOfQ(50%),veh/ln	2.8	2.7	4.3	1.9	2.2	2.2	0.5	7.8	2.2	0.4	14.1	16.2
Unsig. Movement Delay, s/veh												
LnGrp Delay(d),s/veh	54.2	47.5	51.2	53.3	47.0	47.2	5.8	42.9	29.9	14.7	51.4	59.1
LnGrp LOS	D	D	D	D	D	D	A	D	C	B	D	E
Approach Vol, veh/h		340			225			1234			1436	
Approach Delay, s/veh		50.9			48.9			38.6			53.2	
Approach LOS		D			D			D			D	
Timer - Assigned Phs	1	2		4	5	6		8				
Phs Duration (G+Y+Rc), s	56.1	42.0		21.9	65.7	32.4		21.9				
Change Period (Y+Rc), s	6.0	5.7		* 5.4	6.0	5.7		* 5.4				
Max Green Setting (Gmax), s	7.0	74.3		* 22	7.0	74.3		* 22				
Max Q Clear Time (g_c+I1), s	2.0	32.8		14.3	2.0	24.0		16.1				
Green Ext Time (p_c), s	0.0	3.5		0.4	0.0	2.7		0.4				

Intersection Summary

HCM 6th Ctrl Delay	47.1
HCM 6th LOS	D

Notes

User approved pedestrian interval to be less than phase max green.
 * HCM 6th computational engine requires equal clearance times for the phases crossing the barrier.

3: Scottsdale Road & Driveway B

06/15/2022

Intersection												
Int Delay, s/veh	0.1											
Movement	EBL	EBT	EBR	WBL	WBT	WBR	NBL	NBT	NBR	SBL	SBT	SBR
Lane Configurations			↗			↗	↑↑↑			↑↑↑		
Traffic Vol, veh/h	0	0	6	0	0	13	0	1194	0	0	1384	20
Future Vol, veh/h	0	0	6	0	0	13	0	1194	0	0	1384	20
Conflicting Peds, #/hr	0	0	0	0	0	0	0	0	0	0	0	0
Sign Control	Stop	Stop	Stop	Stop	Stop	Stop	Free	Free	Free	Free	Free	Free
RT Channelized	-	-	None	-	-	None	-	-	None	-	-	None
Storage Length	-	-	0	-	-	0	-	-	-	-	-	-
Veh in Median Storage, #	-	0	-	-	0	-	-	0	-	-	0	-
Grade, %	-	0	-	-	0	-	-	0	-	-	0	-
Peak Hour Factor	92	92	92	92	92	92	92	92	92	92	92	92
Heavy Vehicles, %	2	2	2	2	2	2	2	2	2	2	2	2
Mvmt Flow	0	0	7	0	0	14	0	1298	0	0	1504	22

Major/Minor	Minor2		Minor1		Major1		Major2	
Conflicting Flow All	-	-	763	-	-	649	-	0
Stage 1	-	-	-	-	-	-	-	-
Stage 2	-	-	-	-	-	-	-	-
Critical Hdwy	-	-	7.14	-	-	7.14	-	-
Critical Hdwy Stg 1	-	-	-	-	-	-	-	-
Critical Hdwy Stg 2	-	-	-	-	-	-	-	-
Follow-up Hdwy	-	-	3.92	-	-	3.92	-	-
Pot Cap-1 Maneuver	0	0	*610	0	0	*653	0	-
Stage 1	0	0	-	0	0	-	0	-
Stage 2	0	0	-	0	0	-	0	-
Platoon blocked, %			1			1		
Mov Cap-1 Maneuver	-	-	*610	-	-	*653	-	-
Mov Cap-2 Maneuver	-	-	-	-	-	-	-	-
Stage 1	-	-	-	-	-	-	-	-
Stage 2	-	-	-	-	-	-	-	-

Approach	EB	WB	NB	SB
HCM Control Delay, s	11	10.6	0	0
HCM LOS	B	B		

Minor Lane/Major Mvmt	NBT	NBR	EBLn1WBLn1	SBT	SBR
Capacity (veh/h)	-	-	610	653	-
HCM Lane V/C Ratio	-	-	0.011	0.022	-
HCM Control Delay (s)	-	-	11	10.6	-
HCM Lane LOS	-	-	B	B	-
HCM 95th %tile Q(veh)	-	-	0	0.1	-

Notes
 ~: Volume exceeds capacity \$: Delay exceeds 300s +: Computation Not Defined *: All major volume in platoon

4: Scottsdale Road & Acacia Driveway

06/15/2022

Intersection												
Int Delay, s/veh	0.4											
Movement	EBL	EBT	EBR	WBL	WBT	WBR	NBL	NBT	NBR	SBL	SBT	SBR
Lane Configurations		↕			↕		↕ ↑↑↑	↑↑↑	↕	↕ ↑↑↑		
Traffic Vol, veh/h	8	0	27	8	0	20	15	1176	6	9	1410	8
Future Vol, veh/h	8	0	27	8	0	20	15	1176	6	9	1410	8
Conflicting Peds, #/hr	0	0	0	0	0	0	0	0	0	0	0	0
Sign Control	Stop	Stop	Stop	Stop	Stop	Stop	Free	Free	Free	Free	Free	Free
RT Channelized	-	-	None	-	-	None	-	-	None	-	-	None
Storage Length	-	-	-	-	-	-	150	-	100	150	-	-
Veh in Median Storage, #	-	0	-	-	0	-	-	0	-	-	0	-
Grade, %	-	0	-	-	0	-	-	0	-	-	0	-
Peak Hour Factor	92	92	92	92	92	92	92	92	92	92	92	92
Heavy Vehicles, %	2	2	2	2	2	2	2	2	2	2	2	2
Mvmt Flow	9	0	29	9	0	22	16	1278	7	10	1533	9

Major/Minor	Minor2		Minor1		Major1			Major2				
Conflicting Flow All	2101	2875	771	1943	2872	639	1542	0	0	1285	0	0
Stage 1	1558	1558	-	1310	1310	-	-	-	-	-	-	-
Stage 2	543	1317	-	633	1562	-	-	-	-	-	-	-
Critical Hdwy	6.44	6.54	7.14	6.44	6.54	7.14	5.34	-	-	5.34	-	-
Critical Hdwy Stg 1	7.34	5.54	-	7.34	5.54	-	-	-	-	-	-	-
Critical Hdwy Stg 2	6.74	5.54	-	6.74	5.54	-	-	-	-	-	-	-
Follow-up Hdwy	3.82	4.02	3.92	3.82	4.02	3.92	3.12	-	-	3.12	-	-
Pot Cap-1 Maneuver	*227	*40	*588	*315	*40	*653	*740	-	-	*821	-	-
Stage 1	*604	*574	-	*650	*625	-	-	-	-	-	-	-
Stage 2	*670	*618	-	*604	*574	-	-	-	-	-	-	-
Platoon blocked, %	1	1	1	1	1	1	1	-	-	1	-	-
Mov Cap-1 Maneuver	*214	*38	*588	*292	*39	*653	*740	-	-	*821	-	-
Mov Cap-2 Maneuver	*214	*38	-	*292	*39	-	-	-	-	-	-	-
Stage 1	*591	*567	-	*635	*611	-	-	-	-	-	-	-
Stage 2	*634	*605	-	*567	*567	-	-	-	-	-	-	-

Approach	EB		WB		NB		SB	
HCM Control Delay, s	14.4		13		0.1		0.1	
HCM LOS	B		B					

Minor Lane/Major Mvmt	NBL	NBT	NBR	EBLn1	WBLn1	SBL	SBT	SBR
Capacity (veh/h)	*740	-	-	420	483	*821	-	-
HCM Lane V/C Ratio	0.022	-	-	0.091	0.063	0.012	-	-
HCM Control Delay (s)	10	-	-	14.4	13	9.4	-	-
HCM Lane LOS	A	-	-	B	B	A	-	-
HCM 95th %tile Q(veh)	0.1	-	-	0.3	0.2	0	-	-

Notes
 ~: Volume exceeds capacity \$: Delay exceeds 300s +: Computation Not Defined *: All major volume in platoon

Intersection

Int Delay, s/veh 3.9

Movement	EBL	EBT	EBR	WBL	WBT	WBR	NBL	NBT	NBR	SBL	SBT	SBR
Lane Configurations	↶	↷		↶	↷			↕			↕	
Traffic Vol, veh/h	8	90	13	19	141	25	21	6	26	56	5	17
Future Vol, veh/h	8	90	13	19	141	25	21	6	26	56	5	17
Conflicting Peds, #/hr	0	0	0	0	0	0	0	0	0	0	0	0
Sign Control	Free	Free	Free	Free	Free	Free	Stop	Stop	Stop	Stop	Stop	Stop
RT Channelized	-	-	None	-	-	None	-	-	None	-	-	None
Storage Length	100	-	-	100	-	-	-	-	-	-	-	-
Veh in Median Storage, #	-	0	-	-	0	-	-	0	-	-	0	-
Grade, %	-	0	-	-	0	-	-	0	-	-	0	-
Peak Hour Factor	92	92	92	92	92	92	92	92	92	92	92	92
Heavy Vehicles, %	2	2	2	2	2	2	2	2	2	2	2	2
Mvmt Flow	9	98	14	21	153	27	23	7	28	61	5	18

Major/Minor	Major1			Major2			Minor1			Minor2		
Conflicting Flow All	180	0	0	112	0	0	343	345	105	350	339	167
Stage 1	-	-	-	-	-	-	123	123	-	209	209	-
Stage 2	-	-	-	-	-	-	220	222	-	141	130	-
Critical Hdwy	4.12	-	-	4.12	-	-	7.12	6.52	6.22	7.12	6.52	6.22
Critical Hdwy Stg 1	-	-	-	-	-	-	6.12	5.52	-	6.12	5.52	-
Critical Hdwy Stg 2	-	-	-	-	-	-	6.12	5.52	-	6.12	5.52	-
Follow-up Hdwy	2.218	-	-	2.218	-	-	3.518	4.018	3.318	3.518	4.018	3.318
Pot Cap-1 Maneuver	1396	-	-	1478	-	-	611	578	949	605	582	877
Stage 1	-	-	-	-	-	-	881	794	-	793	729	-
Stage 2	-	-	-	-	-	-	782	720	-	862	789	-
Platoon blocked, %	-	-	-	-	-	-	-	-	-	-	-	-
Mov Cap-1 Maneuver	1396	-	-	1478	-	-	585	566	949	573	570	877
Mov Cap-2 Maneuver	-	-	-	-	-	-	585	566	-	573	570	-
Stage 1	-	-	-	-	-	-	876	789	-	788	719	-
Stage 2	-	-	-	-	-	-	749	710	-	824	784	-

Approach	EB			WB			NB			SB		
HCM Control Delay, s	0.5			0.8			10.5			11.7		
HCM LOS							B			B		

Minor Lane/Major Mvmt	NBLn1	EBL	EBT	EBR	WBL	WBT	WBR	SBLn1
Capacity (veh/h)	717	1396	-	-	1478	-	-	620
HCM Lane V/C Ratio	0.08	0.006	-	-	0.014	-	-	0.137
HCM Control Delay (s)	10.5	7.6	-	-	7.5	-	-	11.7
HCM Lane LOS	B	A	-	-	A	-	-	B
HCM 95th %tile Q(veh)	0.3	0	-	-	0	-	-	0.5

2: Scottsdale Road & Gold Dust Avenue

06/15/2022



Movement	EBL	EBT	EBR	WBL	WBT	WBR	NBL	NBT	NBR	SBL	SBT	SBR
Lane Configurations	↘	↑	↗	↘	↕		↘	↕	↗	↘	↕	↗
Traffic Volume (veh/h)	58	65	79	80	72	49	108	1595	77	30	1327	39
Future Volume (veh/h)	58	65	79	80	72	49	108	1595	77	30	1327	39
Initial Q (Qb), veh	0	0	0	0	0	0	0	0	0	0	0	0
Ped-Bike Adj(A_pbT)	1.00		1.00	1.00		1.00	1.00		1.00	1.00		1.00
Parking Bus, Adj	1.00	1.00	1.00	1.00	1.00	1.00	1.00	1.00	1.00	1.00	1.00	1.00
Work Zone On Approach		No			No			No			No	
Adj Sat Flow, veh/h/ln	1870	1870	1870	1870	1870	1870	1870	1870	1870	1870	1870	1870
Adj Flow Rate, veh/h	63	71	86	87	78	53	117	1734	84	33	1442	42
Peak Hour Factor	0.92	0.92	0.92	0.92	0.92	0.92	0.92	0.92	0.92	0.92	0.92	0.92
Percent Heavy Veh, %	2	2	2	2	2	2	2	2	2	2	2	2
Cap, veh/h	169	231	196	169	259	162	814	1947	604	689	1616	47
Arrive On Green	0.12	0.12	0.12	0.12	0.12	0.12	0.42	0.38	0.38	0.35	0.32	0.32
Sat Flow, veh/h	1259	1870	1585	1230	2099	1312	1781	5106	1585	1781	5099	149
Grp Volume(v), veh/h	63	71	86	87	65	66	117	1734	84	33	963	521
Grp Sat Flow(s),veh/h/ln	1259	1870	1585	1230	1777	1634	1781	1702	1585	1781	1702	1844
Q Serve(g_s), s	5.8	4.2	6.0	8.3	4.0	4.4	0.0	38.2	4.2	0.0	32.3	32.3
Cycle Q Clear(g_c), s	10.2	4.2	6.0	12.5	4.0	4.4	0.0	38.2	4.2	0.0	32.3	32.3
Prop In Lane	1.00		1.00	1.00		0.80	1.00		1.00	1.00		0.08
Lane Grp Cap(c), veh/h	169	231	196	169	219	202	814	1947	604	689	1079	584
V/C Ratio(X)	0.37	0.31	0.44	0.51	0.30	0.33	0.14	0.89	0.14	0.05	0.89	0.89
Avail Cap(c_a), veh/h	240	337	285	239	320	294	814	3162	981	689	2108	1142
HCM Platoon Ratio	1.00	1.00	1.00	1.00	1.00	1.00	1.00	1.00	1.00	1.00	1.00	1.00
Upstream Filter(I)	1.00	1.00	1.00	1.00	1.00	1.00	1.00	1.00	1.00	1.00	1.00	1.00
Uniform Delay (d), s/veh	52.7	47.9	48.8	53.6	47.9	48.0	20.2	34.8	24.3	25.1	39.0	39.0
Incr Delay (d2), s/veh	0.5	0.3	0.6	0.9	0.3	0.3	0.0	6.6	0.5	0.0	11.2	18.5
Initial Q Delay(d3),s/veh	0.0	0.0	0.0	0.0	0.0	0.0	0.0	0.0	0.0	0.0	0.0	0.0
%ile BackOfQ(50%),veh/ln	1.9	2.0	2.4	2.6	1.8	1.8	1.9	16.3	1.6	0.6	14.7	17.1
Unsig. Movement Delay, s/veh												
LnGrp Delay(d),s/veh	53.2	48.2	49.3	54.5	48.1	48.4	20.2	41.4	24.7	25.1	50.3	57.5
LnGrp LOS	D	D	D	D	D	D	C	D	C	C	D	E
Approach Vol, veh/h		220			218			1935			1517	
Approach Delay, s/veh		50.1			50.8			39.4			52.2	
Approach LOS		D			D			D			D	
Timer - Assigned Phs	1	2		4	5	6		8				
Phs Duration (G+Y+Rc), s	56.1	43.7		20.2	48.3	51.5		20.2				
Change Period (Y+Rc), s	6.0	5.7		* 5.4	6.0	5.7		* 5.4				
Max Green Setting (Gmax), s	7.0	74.3		* 22	7.0	74.3		* 22				
Max Q Clear Time (g_c+I1), s	2.0	34.3		14.5	2.0	40.2		12.2				
Green Ext Time (p_c), s	0.1	3.7		0.3	0.0	5.6		0.3				

Intersection Summary

HCM 6th Ctrl Delay	45.7
HCM 6th LOS	D

Notes

User approved pedestrian interval to be less than phase max green.
 * HCM 6th computational engine requires equal clearance times for the phases crossing the barrier.

3: Scottsdale Road & Driveway B

06/15/2022

Intersection												
Int Delay, s/veh	0.1											
Movement	EBL	EBT	EBR	WBL	WBT	WBR	NBL	NBT	NBR	SBL	SBT	SBR
Lane Configurations			↗			↗	↑↑↑			↑↑↑		
Traffic Vol, veh/h	0	0	19	0	0	16	0	1761	2	0	1456	28
Future Vol, veh/h	0	0	19	0	0	16	0	1761	2	0	1456	28
Conflicting Peds, #/hr	0	0	0	0	0	0	0	0	0	0	0	0
Sign Control	Stop	Stop	Stop	Stop	Stop	Stop	Free	Free	Free	Free	Free	Free
RT Channelized	-	-	None	-	-	None	-	-	None	-	-	None
Storage Length	-	-	0	-	-	0	-	-	-	-	-	-
Veh in Median Storage, #	-	0	-	-	0	-	-	0	-	-	0	-
Grade, %	-	0	-	-	0	-	-	0	-	-	0	-
Peak Hour Factor	92	92	92	92	92	92	92	92	92	92	92	92
Heavy Vehicles, %	2	2	2	2	2	2	2	2	2	2	2	2
Mvmt Flow	0	0	21	0	0	17	0	1914	2	0	1583	30

Major/Minor	Minor2		Minor1		Major1		Major2	
Conflicting Flow All	-	-	807	-	-	958	-	0
Stage 1	-	-	-	-	-	-	-	-
Stage 2	-	-	-	-	-	-	-	-
Critical Hdwy	-	-	7.14	-	-	7.14	-	-
Critical Hdwy Stg 1	-	-	-	-	-	-	-	-
Critical Hdwy Stg 2	-	-	-	-	-	-	-	-
Follow-up Hdwy	-	-	3.92	-	-	3.92	-	-
Pot Cap-1 Maneuver	0	0	*588	0	0	*502	0	-
Stage 1	0	0	-	0	0	-	0	-
Stage 2	0	0	-	0	0	-	0	-
Platoon blocked, %			1			1	-	-
Mov Cap-1 Maneuver	-	-	*588	-	-	*502	-	-
Mov Cap-2 Maneuver	-	-	-	-	-	-	-	-
Stage 1	-	-	-	-	-	-	-	-
Stage 2	-	-	-	-	-	-	-	-

Approach	EB		WB		NB		SB	
HCM Control Delay, s	11.3		12.4		0		0	
HCM LOS	B		B					

Minor Lane/Major Mvmt	NBT	NBR	EBLn1WBLn1	SBT	SBR
Capacity (veh/h)	-	-	588	502	-
HCM Lane V/C Ratio	-	-	0.035	0.035	-
HCM Control Delay (s)	-	-	11.3	12.4	-
HCM Lane LOS	-	-	B	B	-
HCM 95th %tile Q(veh)	-	-	0.1	0.1	-

Notes
 ~: Volume exceeds capacity \$: Delay exceeds 300s +: Computation Not Defined *: All major volume in platoon

4: Scottsdale Road & Acacia Driveway

06/15/2022

Intersection												
Int Delay, s/veh	0.6											
Movement	EBL	EBT	EBR	WBL	WBT	WBR	NBL	NBT	NBR	SBL	SBT	SBR
Lane Configurations		↕			↕		↕ ↑↑↑	↑↑↑	↕	↕ ↑↑↑		
Traffic Vol, veh/h	7	2	36	4	2	11	51	1742	7	24	1471	21
Future Vol, veh/h	7	2	36	4	2	11	51	1742	7	24	1471	21
Conflicting Peds, #/hr	0	0	0	0	0	0	0	0	0	0	0	0
Sign Control	Stop	Stop	Stop	Stop	Stop	Stop	Free	Free	Free	Free	Free	Free
RT Channelized	-	-	None	-	-	None	-	-	None	-	-	None
Storage Length	-	-	-	-	-	-	150	-	100	150	-	-
Veh in Median Storage, #	-	0	-	-	0	-	-	0	-	-	0	-
Grade, %	-	0	-	-	0	-	-	0	-	-	0	-
Peak Hour Factor	92	92	92	92	92	92	92	92	92	92	92	92
Heavy Vehicles, %	2	2	2	2	2	2	2	2	2	2	2	2
Mvmt Flow	8	2	39	4	2	12	55	1893	8	26	1599	23

Major/Minor	Minor2		Minor1		Major1			Major2				
Conflicting Flow All	2531	3674	811	2696	3677	947	1622	0	0	1901	0	0
Stage 1	1663	1663	-	2003	2003	-	-	-	-	-	-	-
Stage 2	868	2011	-	693	1674	-	-	-	-	-	-	-
Critical Hdwy	6.44	6.54	7.14	6.44	6.54	7.14	5.34	-	-	5.34	-	-
Critical Hdwy Stg 1	7.34	5.54	-	7.34	5.54	-	-	-	-	-	-	-
Critical Hdwy Stg 2	6.74	5.54	-	6.74	5.54	-	-	-	-	-	-	-
Follow-up Hdwy	3.82	4.02	3.92	3.82	4.02	3.92	3.12	-	-	3.12	-	-
Pot Cap-1 Maneuver	*200	86	*588	*200	84	*524	729	-	-	*658	-	-
Stage 1	*537	532	-	*444	451	-	-	-	-	-	-	-
Stage 2	*537	445	-	*604	523	-	-	-	-	-	-	-
Platoon blocked, %	1	1	1	1	1	1	1	-	-	1	-	-
Mov Cap-1 Maneuver	*175	76	*588	*167	75	*524	729	-	-	*658	-	-
Mov Cap-2 Maneuver	*175	76	-	*167	75	-	-	-	-	-	-	-
Stage 1	*497	511	-	*410	417	-	-	-	-	-	-	-
Stage 2	*483	411	-	*539	502	-	-	-	-	-	-	-

Approach	EB		WB		NB		SB	
HCM Control Delay, s	16.8		21.5		0.3		0.2	
HCM LOS	C		C					

Minor Lane/Major Mvmt	NBL	NBT	NBR	EBLn1WBLn1	SBL	SBT	SBR
Capacity (veh/h)	729	-	-	353	237	*658	-
HCM Lane V/C Ratio	0.076	-	-	0.139	0.078	0.04	-
HCM Control Delay (s)	10.3	-	-	16.8	21.5	10.7	-
HCM Lane LOS	B	-	-	C	C	B	-
HCM 95th %tile Q(veh)	0.2	-	-	0.5	0.3	0.1	-

Notes
 ~: Volume exceeds capacity \$: Delay exceeds 300s +: Computation Not Defined *: All major volume in platoon



Appendix J – Year 2025 Build Capacity Analysis

Intersection												
Int Delay, s/veh	2.1											
Movement	EBL	EBT	EBR	WBL	WBT	WBR	NBL	NBT	NBR	SBL	SBT	SBR
Lane Configurations	↶	↷		↶	↷			↕			↕	
Traffic Vol, veh/h	6	147	6	17	207	16	12	2	38	15	2	10
Future Vol, veh/h	6	147	6	17	207	16	12	2	38	15	2	10
Conflicting Peds, #/hr	0	0	0	0	0	0	0	0	0	0	0	0
Sign Control	Free	Free	Free	Free	Free	Free	Stop	Stop	Stop	Stop	Stop	Stop
RT Channelized	-	-	None	-	-	None	-	-	None	-	-	None
Storage Length	100	-	-	100	-	-	-	-	-	-	-	-
Veh in Median Storage, #	-	0	-	-	0	-	-	0	-	-	0	-
Grade, %	-	0	-	-	0	-	-	0	-	-	0	-
Peak Hour Factor	92	92	92	92	92	92	92	92	92	92	92	92
Heavy Vehicles, %	2	2	2	2	2	2	2	2	2	2	2	2
Mvmt Flow	7	160	7	18	225	17	13	2	41	16	2	11

Major/Minor	Major1			Major2			Minor1			Minor2		
Conflicting Flow All	242	0	0	167	0	0	454	456	164	469	451	234
Stage 1	-	-	-	-	-	-	178	178	-	270	270	-
Stage 2	-	-	-	-	-	-	276	278	-	199	181	-
Critical Hdwy	4.12	-	-	4.12	-	-	7.12	6.52	6.22	7.12	6.52	6.22
Critical Hdwy Stg 1	-	-	-	-	-	-	6.12	5.52	-	6.12	5.52	-
Critical Hdwy Stg 2	-	-	-	-	-	-	6.12	5.52	-	6.12	5.52	-
Follow-up Hdwy	2.218	-	-	2.218	-	-	3.518	4.018	3.318	3.518	4.018	3.318
Pot Cap-1 Maneuver	1324	-	-	1411	-	-	516	501	881	505	504	805
Stage 1	-	-	-	-	-	-	824	752	-	736	686	-
Stage 2	-	-	-	-	-	-	730	680	-	803	750	-
Platoon blocked, %	-	-	-	-	-	-	-	-	-	-	-	-
Mov Cap-1 Maneuver	1324	-	-	1411	-	-	501	492	881	473	495	805
Mov Cap-2 Maneuver	-	-	-	-	-	-	501	492	-	473	495	-
Stage 1	-	-	-	-	-	-	820	748	-	732	677	-
Stage 2	-	-	-	-	-	-	709	671	-	759	746	-

Approach	EB			WB			NB			SB		
HCM Control Delay, s	0.3			0.5			10.3			11.8		
HCM LOS							B			B		

Minor Lane/Major Mvmt	NBLn1	EBL	EBT	EBR	WBL	WBT	WBR	SBLn1
Capacity (veh/h)	731	1324	-	-	1411	-	-	560
HCM Lane V/C Ratio	0.077	0.005	-	-	0.013	-	-	0.052
HCM Control Delay (s)	10.3	7.7	-	-	7.6	-	-	11.8
HCM Lane LOS	B	A	-	-	A	-	-	B
HCM 95th %tile Q(veh)	0.3	0	-	-	0	-	-	0.2

2: Scottsdale Road & Gold Dust Avenue

11/02/2022

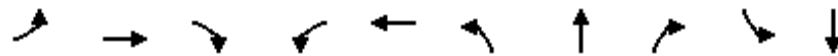

Lane Group	EBL	EBT	EBR	WBL	WBT	NBL	NBT	NBR	SBL	SBT
Lane Group Flow (vph)	113	104	151	65	163	105	1023	116	32	1415
v/c Ratio	0.72	0.43	0.45	0.41	0.34	0.38	0.29	0.10	0.07	0.41
Control Delay	72.9	51.7	11.8	53.8	36.6	12.3	9.3	2.3	5.1	9.5
Queue Delay	0.0	0.0	0.0	0.0	0.0	0.0	0.0	0.0	0.0	0.0
Total Delay	72.9	51.7	11.8	53.8	36.6	12.3	9.3	2.3	5.1	9.5
Queue Length 50th (ft)	85	75	3	47	46	16	117	0	5	156
Queue Length 95th (ft)	140	122	59	87	74	40	188	27	16	241
Internal Link Dist (ft)		130			1006		246			672
Turn Bay Length (ft)	100		60	100		150		160	160	
Base Capacity (vph)	247	381	441	246	726	296	3562	1143	455	3437
Starvation Cap Reductn	0	0	0	0	0	0	0	0	0	0
Spillback Cap Reductn	0	0	0	0	0	0	0	0	0	0
Storage Cap Reductn	0	0	0	0	0	0	0	0	0	0
Reduced v/c Ratio	0.46	0.27	0.34	0.26	0.22	0.35	0.29	0.10	0.07	0.41

Intersection Summary

2: Scottsdale Road & Gold Dust Avenue

11/02/2022



Movement	EBL	EBT	EBR	WBL	WBT	WBR	NBL	NBT	NBR	SBL	SBT	SBR
Lane Configurations	↖	↑	↗	↖	↕		↖	↕	↗	↖	↕	↗
Traffic Volume (veh/h)	104	96	139	60	110	40	97	941	107	29	1220	82
Future Volume (veh/h)	104	96	139	60	110	40	97	941	107	29	1220	82
Initial Q (Qb), veh	0	0	0	0	0	0	0	0	0	0	0	0
Ped-Bike Adj(A_pbT)	1.00		1.00	1.00		1.00	1.00		1.00	1.00		1.00
Parking Bus, Adj	1.00	1.00	1.00	1.00	1.00	1.00	1.00	1.00	1.00	1.00	1.00	1.00
Work Zone On Approach		No			No			No			No	
Adj Sat Flow, veh/h/ln	1870	1870	1870	1870	1870	1870	1870	1870	1870	1870	1870	1870
Adj Flow Rate, veh/h	113	104	151	65	120	43	105	1023	116	32	1326	89
Peak Hour Factor	0.92	0.92	0.92	0.92	0.92	0.92	0.92	0.92	0.92	0.92	0.92	0.92
Percent Heavy Veh, %	2	2	2	2	2	2	2	2	2	2	2	2
Cap, veh/h	196	288	244	177	400	138	770	1144	355	925	1489	100
Arrive On Green	0.15	0.15	0.15	0.15	0.15	0.15	0.80	0.45	0.45	0.48	0.30	0.30
Sat Flow, veh/h	1223	1870	1585	1125	2595	892	1781	5106	1585	1781	4887	328
Grp Volume(v), veh/h	113	104	151	65	81	82	105	1023	116	32	924	491
Grp Sat Flow(s),veh/h/ln	1223	1870	1585	1125	1777	1710	1781	1702	1585	1781	1702	1811
Q Serve(g_s), s	10.9	6.0	10.7	6.6	4.8	5.1	0.0	22.1	5.7	0.0	31.1	31.1
Cycle Q Clear(g_c), s	16.0	6.0	10.7	12.6	4.8	5.1	0.0	22.1	5.7	0.0	31.1	31.1
Prop In Lane	1.00		1.00	1.00		0.52	1.00		1.00	1.00		0.18
Lane Grp Cap(c), veh/h	196	288	244	177	274	264	770	1144	355	925	1037	552
V/C Ratio(X)	0.58	0.36	0.62	0.37	0.29	0.31	0.14	0.89	0.33	0.03	0.89	0.89
Avail Cap(c_a), veh/h	258	383	325	235	364	351	770	3034	942	925	2023	1076
HCM Platoon Ratio	1.00	1.00	1.00	1.00	1.00	1.00	2.00	2.00	2.00	1.00	1.00	1.00
Upstream Filter(I)	1.00	1.00	1.00	1.00	1.00	1.00	1.00	1.00	1.00	1.00	1.00	1.00
Uniform Delay (d), s/veh	52.2	45.4	47.4	51.1	45.0	45.1	7.3	31.8	27.3	15.8	39.8	39.8
Incr Delay (d2), s/veh	1.0	0.3	0.9	0.5	0.2	0.2	0.0	10.9	2.4	0.0	11.4	19.1
Initial Q Delay(d3),s/veh	0.0	0.0	0.0	0.0	0.0	0.0	0.0	0.0	0.0	0.0	0.0	0.0
%ile BackOfQ(50%),veh/ln	3.4	2.8	4.3	1.9	2.1	2.2	0.6	7.8	2.2	0.4	14.2	16.3
Unsig. Movement Delay, s/veh												
LnGrp Delay(d),s/veh	53.2	45.7	48.4	51.5	45.2	45.3	7.4	42.7	29.7	15.8	51.2	58.9
LnGrp LOS	D	D	D	D	D	D	A	D	C	B	D	E
Approach Vol, veh/h		368			228			1244			1447	
Approach Delay, s/veh		49.1			47.1			38.5			53.1	
Approach LOS		D			D			D			D	
Timer - Assigned Phs	1	2		4	5	6		8				
Phs Duration (G+Y+Rc), s	53.8	42.3		23.9	63.5	32.6		23.9				
Change Period (Y+Rc), s	6.0	5.7		* 5.4	6.0	5.7		* 5.4				
Max Green Setting (Gmax), s	7.0	71.3		* 25	7.0	71.3		* 25				
Max Q Clear Time (g_c+I1), s	2.0	33.1		14.6	2.0	24.1		18.0				
Green Ext Time (p_c), s	0.0	3.5		0.5	0.0	2.7		0.5				

Intersection Summary

HCM 6th Ctrl Delay	46.7
HCM 6th LOS	D

Notes

User approved pedestrian interval to be less than phase max green.
 * HCM 6th computational engine requires equal clearance times for the phases crossing the barrier.

3: Scottsdale Road & Driveway B

11/02/2022

Intersection												
Int Delay, s/veh	0.2											
Movement	EBL	EBT	EBR	WBL	WBT	WBR	NBL	NBT	NBR	SBL	SBT	SBR
Lane Configurations			↗			↗	↑↑↑				↑↑↑	
Traffic Vol, veh/h	0	0	29	0	0	13	0	1203	0	0	1388	24
Future Vol, veh/h	0	0	29	0	0	13	0	1203	0	0	1388	24
Conflicting Peds, #/hr	0	0	0	0	0	0	0	0	0	0	0	0
Sign Control	Stop	Stop	Stop	Stop	Stop	Stop	Free	Free	Free	Free	Free	Free
RT Channelized	-	-	None	-	-	None	-	-	None	-	-	None
Storage Length	-	-	0	-	-	0	-	-	-	-	-	-
Veh in Median Storage, #	-	0	-	-	0	-	-	0	-	-	0	-
Grade, %	-	0	-	-	0	-	-	0	-	-	0	-
Peak Hour Factor	92	92	92	92	92	92	92	92	92	92	92	92
Heavy Vehicles, %	2	2	2	2	2	2	2	2	2	2	2	2
Mvmt Flow	0	0	32	0	0	14	0	1308	0	0	1509	26

Major/Minor	Minor2		Minor1		Major1		Major2					
Conflicting Flow All	-	-	768	-	-	654	-	0	0	-	-	0
Stage 1	-	-	-	-	-	-	-	-	-	-	-	-
Stage 2	-	-	-	-	-	-	-	-	-	-	-	-
Critical Hdwy	-	-	7.14	-	-	7.14	-	-	-	-	-	-
Critical Hdwy Stg 1	-	-	-	-	-	-	-	-	-	-	-	-
Critical Hdwy Stg 2	-	-	-	-	-	-	-	-	-	-	-	-
Follow-up Hdwy	-	-	3.92	-	-	3.92	-	-	-	-	-	-
Pot Cap-1 Maneuver	0	0	*610	0	0	*653	0	-	-	0	-	-
Stage 1	0	0	-	0	0	-	0	-	-	0	-	-
Stage 2	0	0	-	0	0	-	0	-	-	0	-	-
Platoon blocked, %			1			1		-	-		-	-
Mov Cap-1 Maneuver	-	-	*610	-	-	*653	-	-	-	-	-	-
Mov Cap-2 Maneuver	-	-	-	-	-	-	-	-	-	-	-	-
Stage 1	-	-	-	-	-	-	-	-	-	-	-	-
Stage 2	-	-	-	-	-	-	-	-	-	-	-	-

Approach	EB		WB		NB		SB	
HCM Control Delay, s	11.2		10.6		0		0	
HCM LOS	B		B					

Minor Lane/Major Mvmt	NBT	NBR	EBLn1	WBLn1	SBT	SBR
Capacity (veh/h)	-	-	610	653	-	-
HCM Lane V/C Ratio	-	-	0.052	0.022	-	-
HCM Control Delay (s)	-	-	11.2	10.6	-	-
HCM Lane LOS	-	-	B	B	-	-
HCM 95th %tile Q(veh)	-	-	0.2	0.1	-	-

Notes
 ~: Volume exceeds capacity \$: Delay exceeds 300s +: Computation Not Defined *: All major volume in platoon

4: Scottsdale Road & Acacia Driveway

11/02/2022

Intersection												
Int Delay, s/veh	0.5											
Movement	EBL	EBT	EBR	WBL	WBT	WBR	NBL	NBT	NBR	SBL	SBT	SBR
Lane Configurations		↕			↕		↕ ↑↑↑	↑↑↑	↕	↕ ↑↑↑		
Traffic Vol, veh/h	12	0	27	8	0	20	18	1179	6	9	1437	7
Future Vol, veh/h	12	0	27	8	0	20	18	1179	6	9	1437	7
Conflicting Peds, #/hr	0	0	0	0	0	0	0	0	0	0	0	0
Sign Control	Stop	Stop	Stop	Stop	Stop	Stop	Free	Free	Free	Free	Free	Free
RT Channelized	-	-	None	-	-	None	-	-	None	-	-	None
Storage Length	-	-	-	-	-	-	150	-	100	150	-	-
Veh in Median Storage, #	-	0	-	-	0	-	-	0	-	-	0	-
Grade, %	-	0	-	-	0	-	-	0	-	-	0	-
Peak Hour Factor	92	92	92	92	92	92	92	92	92	92	92	92
Heavy Vehicles, %	2	2	2	2	2	2	2	2	2	2	2	2
Mvmt Flow	13	0	29	9	0	22	20	1282	7	10	1562	8

Major/Minor	Minor2		Minor1		Major1		Major2					
Conflicting Flow All	2139	2915	785	1967	2912	641	1570	0	0	1289	0	0
Stage 1	1586	1586	-	1322	1322	-	-	-	-	-	-	-
Stage 2	553	1329	-	645	1590	-	-	-	-	-	-	-
Critical Hdwy	6.44	6.54	7.14	6.44	6.54	7.14	5.34	-	-	5.34	-	-
Critical Hdwy Stg 1	7.34	5.54	-	7.34	5.54	-	-	-	-	-	-	-
Critical Hdwy Stg 2	6.74	5.54	-	6.74	5.54	-	-	-	-	-	-	-
Follow-up Hdwy	3.82	4.02	3.92	3.82	4.02	3.92	3.12	-	-	3.12	-	-
Pot Cap-1 Maneuver	*210	*37	*588	*300	*37	*653	*740	-	-	*821	-	-
Stage 1	*604	*574	-	*633	*614	-	-	-	-	-	-	-
Stage 2	*670	*608	-	*604	*574	-	-	-	-	-	-	-
Platoon blocked, %	1	1	1	1	1	1	1	-	-	1	-	-
Mov Cap-1 Maneuver	*197	*35	*588	*276	*35	*653	*740	-	-	*821	-	-
Mov Cap-2 Maneuver	*197	*35	-	*276	*35	-	-	-	-	-	-	-
Stage 1	*588	*567	-	*616	*597	-	-	-	-	-	-	-
Stage 2	*630	*592	-	*567	*567	-	-	-	-	-	-	-

Approach	EB		WB		NB		SB	
HCM Control Delay, s	16.2		13.2		0.1		0.1	
HCM LOS	C		B					

Minor Lane/Major Mvmt	NBL	NBT	NBR	EBLn1	WBLn1	SBL	SBT	SBR
Capacity (veh/h)	*740	-	-	365	470	*821	-	-
HCM Lane V/C Ratio	0.026	-	-	0.116	0.065	0.012	-	-
HCM Control Delay (s)	10	-	-	16.2	13.2	9.4	-	-
HCM Lane LOS	A	-	-	C	B	A	-	-
HCM 95th %tile Q(veh)	0.1	-	-	0.4	0.2	0	-	-

Notes
 ~: Volume exceeds capacity \$: Delay exceeds 300s +: Computation Not Defined *: All major volume in platoon

Intersection												
Int Delay, s/veh	4.2											
Movement	EBL	EBT	EBR	WBL	WBT	WBR	NBL	NBT	NBR	SBL	SBT	SBR
Lane Configurations	↶	↷		↶	↷			↕			↕	
Traffic Vol, veh/h	8	90	11	36	141	25	16	4	39	56	3	17
Future Vol, veh/h	8	90	11	36	141	25	16	4	39	56	3	17
Conflicting Peds, #/hr	0	0	0	0	0	0	0	0	0	0	0	0
Sign Control	Free	Free	Free	Free	Free	Free	Stop	Stop	Stop	Stop	Stop	Stop
RT Channelized	-	-	None	-	-	None	-	-	None	-	-	None
Storage Length	100	-	-	100	-	-	-	-	-	-	-	-
Veh in Median Storage, #	-	0	-	-	0	-	-	0	-	-	0	-
Grade, %	-	0	-	-	0	-	-	0	-	-	0	-
Peak Hour Factor	92	92	92	92	92	92	92	92	92	92	92	92
Heavy Vehicles, %	2	2	2	2	2	2	2	2	2	2	2	2
Mvmt Flow	9	98	12	39	153	27	17	4	42	61	3	18

Major/Minor	Major1			Major2			Minor1			Minor2		
Conflicting Flow All	180	0	0	110	0	0	377	380	104	390	373	167
Stage 1	-	-	-	-	-	-	122	122	-	245	245	-
Stage 2	-	-	-	-	-	-	255	258	-	145	128	-
Critical Hdwy	4.12	-	-	4.12	-	-	7.12	6.52	6.22	7.12	6.52	6.22
Critical Hdwy Stg 1	-	-	-	-	-	-	6.12	5.52	-	6.12	5.52	-
Critical Hdwy Stg 2	-	-	-	-	-	-	6.12	5.52	-	6.12	5.52	-
Follow-up Hdwy	2.218	-	-	2.218	-	-	3.518	4.018	3.318	3.518	4.018	3.318
Pot Cap-1 Maneuver	1396	-	-	1480	-	-	580	552	951	569	557	877
Stage 1	-	-	-	-	-	-	882	795	-	759	703	-
Stage 2	-	-	-	-	-	-	749	694	-	858	790	-
Platoon blocked, %	-	-	-	-	-	-	-	-	-	-	-	-
Mov Cap-1 Maneuver	1396	-	-	1480	-	-	551	534	951	527	539	877
Mov Cap-2 Maneuver	-	-	-	-	-	-	551	534	-	527	539	-
Stage 1	-	-	-	-	-	-	877	790	-	754	685	-
Stage 2	-	-	-	-	-	-	710	676	-	810	785	-

Approach	EB			WB			NB			SB		
HCM Control Delay, s	0.6			1.3			10.2			12.3		
HCM LOS							B			B		

Minor Lane/Major Mvmt	NBLn1	EBL	EBT	EBR	WBL	WBT	WBR	SBLn1
Capacity (veh/h)	761	1396	-	-	1480	-	-	579
HCM Lane V/C Ratio	0.084	0.006	-	-	0.026	-	-	0.143
HCM Control Delay (s)	10.2	7.6	-	-	7.5	-	-	12.3
HCM Lane LOS	B	A	-	-	A	-	-	B
HCM 95th %tile Q(veh)	0.3	0	-	-	0.1	-	-	0.5

2: Scottsdale Road & Gold Dust Avenue

11/02/2022

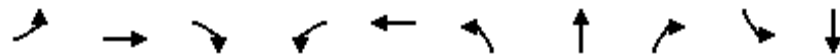

Lane Group	EBL	EBT	EBR	WBL	WBT	NBL	NBT	NBR	SBL	SBT
Lane Group Flow (vph)	82	73	88	90	135	135	1738	84	33	1517
v/c Ratio	0.63	0.37	0.36	0.65	0.34	0.47	0.46	0.07	0.15	0.43
Control Delay	71.5	54.0	13.7	71.9	31.1	14.4	2.1	0.2	6.2	8.9
Queue Delay	0.0	0.0	0.0	0.0	0.0	0.0	0.0	0.0	0.0	0.0
Total Delay	71.5	54.0	13.7	71.9	31.1	14.4	2.1	0.2	6.2	8.9
Queue Length 50th (ft)	62	54	0	68	31	9	72	1	4	168
Queue Length 95th (ft)	112	97	47	119	60	60	61	0	13	245
Internal Link Dist (ft)		130			1006		246			672
Turn Bay Length (ft)	100		60	100		150		160	160	
Base Capacity (vph)	192	288	319	204	560	307	3793	1201	256	3535
Starvation Cap Reductn	0	0	0	0	0	0	0	0	0	0
Spillback Cap Reductn	0	0	0	0	0	0	0	0	0	0
Storage Cap Reductn	0	0	0	0	0	0	0	0	0	0
Reduced v/c Ratio	0.43	0.25	0.28	0.44	0.24	0.44	0.46	0.07	0.13	0.43

Intersection Summary

2: Scottsdale Road & Gold Dust Avenue

11/02/2022



Movement	EBL	EBT	EBR	WBL	WBT	WBR	NBL	NBT	NBR	SBL	SBT	SBR
Lane Configurations	↘	↑	↗	↘	↕		↘	↕	↗	↘	↕	↗
Traffic Volume (veh/h)	75	67	81	83	75	49	124	1599	77	30	1352	43
Future Volume (veh/h)	75	67	81	83	75	49	124	1599	77	30	1352	43
Initial Q (Qb), veh	0	0	0	0	0	0	0	0	0	0	0	0
Ped-Bike Adj(A_pbT)	1.00		1.00	1.00		1.00	1.00		1.00	1.00		1.00
Parking Bus, Adj	1.00	1.00	1.00	1.00	1.00	1.00	1.00	1.00	1.00	1.00	1.00	1.00
Work Zone On Approach		No			No			No			No	
Adj Sat Flow, veh/h/ln	1870	1870	1870	1870	1870	1870	1870	1870	1870	1870	1870	1870
Adj Flow Rate, veh/h	82	73	88	90	82	53	135	1738	84	33	1470	47
Peak Hour Factor	0.92	0.92	0.92	0.92	0.92	0.92	0.92	0.92	0.92	0.92	0.92	0.92
Percent Heavy Veh, %	2	2	2	2	2	2	2	2	2	2	2	2
Cap, veh/h	171	236	200	171	270	161	797	1952	606	683	1645	53
Arrive On Green	0.13	0.13	0.13	0.13	0.13	0.13	0.41	0.38	0.38	0.35	0.32	0.32
Sat Flow, veh/h	1254	1870	1585	1225	2139	1278	1781	5106	1585	1781	5083	163
Grp Volume(v), veh/h	82	73	88	90	67	68	135	1738	84	33	985	532
Grp Sat Flow(s),veh/h/ln	1254	1870	1585	1225	1777	1640	1781	1702	1585	1781	1702	1841
Q Serve(g_s), s	7.7	4.3	6.2	8.7	4.1	4.5	0.7	38.3	4.1	0.0	33.0	33.0
Cycle Q Clear(g_c), s	12.2	4.3	6.2	12.9	4.1	4.5	0.7	38.3	4.1	0.0	33.0	33.0
Prop In Lane	1.00		1.00	1.00		0.78	1.00		1.00	1.00		0.09
Lane Grp Cap(c), veh/h	171	236	200	171	224	207	797	1952	606	683	1102	596
V/C Ratio(X)	0.48	0.31	0.44	0.53	0.30	0.33	0.17	0.89	0.14	0.05	0.89	0.89
Avail Cap(c_a), veh/h	207	290	246	206	275	254	797	3247	1008	683	2164	1171
HCM Platoon Ratio	1.00	1.00	1.00	1.00	1.00	1.00	1.00	1.00	1.00	1.00	1.00	1.00
Upstream Filter(I)	1.00	1.00	1.00	1.00	1.00	1.00	1.00	1.00	1.00	1.00	1.00	1.00
Uniform Delay (d), s/veh	53.4	47.7	48.5	53.6	47.6	47.8	20.9	34.7	24.2	25.4	38.6	38.6
Incr Delay (d2), s/veh	0.8	0.3	0.6	0.9	0.3	0.3	0.0	6.6	0.5	0.0	11.1	18.3
Initial Q Delay(d3),s/veh	0.0	0.0	0.0	0.0	0.0	0.0	0.0	0.0	0.0	0.0	0.0	0.0
%ile BackOfQ(50%),veh/ln	2.5	2.0	2.5	2.7	1.8	1.9	2.2	16.3	1.6	0.6	15.0	17.4
Unsig. Movement Delay, s/veh												
LnGrp Delay(d),s/veh	54.1	48.0	49.1	54.5	47.9	48.2	20.9	41.3	24.7	25.4	49.7	56.9
LnGrp LOS	D	D	D	D	D	D	C	D	C	C	D	E
Approach Vol, veh/h		243			225			1957			1550	
Approach Delay, s/veh		50.5			50.6			39.2			51.7	
Approach LOS		D			D			D			D	
Timer - Assigned Phs	1	2		4	5	6		8				
Phs Duration (G+Y+Rc), s	54.9	44.5		20.5	47.9	51.6		20.5				
Change Period (Y+Rc), s	6.0	5.7		* 5.4	6.0	5.7		* 5.4				
Max Green Setting (Gmax), s	8.0	76.3		* 19	8.0	76.3		* 19				
Max Q Clear Time (g_c+I1), s	2.7	35.0		14.9	2.0	40.3		14.2				
Green Ext Time (p_c), s	0.1	3.8		0.2	0.0	5.6		0.2				

Intersection Summary

HCM 6th Ctrl Delay	45.4
HCM 6th LOS	D

Notes

User approved pedestrian interval to be less than phase max green.
 * HCM 6th computational engine requires equal clearance times for the phases crossing the barrier.

3: Scottsdale Road & Driveway B

11/02/2022

Intersection												
Int Delay, s/veh	0.2											
Movement	EBL	EBT	EBR	WBL	WBT	WBR	NBL	NBT	NBR	SBL	SBT	SBR
Lane Configurations			↗			↗	↑↑↑			↑↑↑		
Traffic Vol, veh/h	0	0	27	0	0	16	0	1781	2	0	1461	44
Future Vol, veh/h	0	0	27	0	0	16	0	1781	2	0	1461	44
Conflicting Peds, #/hr	0	0	0	0	0	0	0	0	0	0	0	0
Sign Control	Stop	Stop	Stop	Stop	Stop	Stop	Free	Free	Free	Free	Free	Free
RT Channelized	-	-	None	-	-	None	-	-	None	-	-	None
Storage Length	-	-	0	-	-	0	-	-	-	-	-	-
Veh in Median Storage, #	-	0	-	-	0	-	-	0	-	-	0	-
Grade, %	-	0	-	-	0	-	-	0	-	-	0	-
Peak Hour Factor	92	92	92	92	92	92	92	92	92	92	92	92
Heavy Vehicles, %	2	2	2	2	2	2	2	2	2	2	2	2
Mvmt Flow	0	0	29	0	0	17	0	1936	2	0	1588	48

Major/Minor	Minor2		Minor1		Major1		Major2	
Conflicting Flow All	-	-	818	-	-	969	-	0
Stage 1	-	-	-	-	-	-	-	-
Stage 2	-	-	-	-	-	-	-	-
Critical Hdwy	-	-	7.14	-	-	7.14	-	-
Critical Hdwy Stg 1	-	-	-	-	-	-	-	-
Critical Hdwy Stg 2	-	-	-	-	-	-	-	-
Follow-up Hdwy	-	-	3.92	-	-	3.92	-	-
Pot Cap-1 Maneuver	0	0	*588	0	0	*502	0	-
Stage 1	0	0	-	0	0	-	0	-
Stage 2	0	0	-	0	0	-	0	-
Platoon blocked, %			1			1		
Mov Cap-1 Maneuver	-	-	*588	-	-	*502	-	-
Mov Cap-2 Maneuver	-	-	-	-	-	-	-	-
Stage 1	-	-	-	-	-	-	-	-
Stage 2	-	-	-	-	-	-	-	-

Approach	EB		WB		NB		SB	
HCM Control Delay, s	11.4		12.4		0		0	
HCM LOS	B		B					

Minor Lane/Major Mvmt	NBT	NBR	EBLn1	WBLn1	SBT	SBR
Capacity (veh/h)	-	-	588	502	-	-
HCM Lane V/C Ratio	-	-	0.05	0.035	-	-
HCM Control Delay (s)	-	-	11.4	12.4	-	-
HCM Lane LOS	-	-	B	B	-	-
HCM 95th %tile Q(veh)	-	-	0.2	0.1	-	-

Notes
 ~: Volume exceeds capacity \$: Delay exceeds 300s +: Computation Not Defined *: All major volume in platoon

4: Scottsdale Road & Acacia Driveway

11/02/2022

Intersection												
Int Delay, s/veh	0.5											
Movement	EBL	EBT	EBR	WBL	WBT	WBR	NBL	NBT	NBR	SBL	SBT	SBR
Lane Configurations		↕			↕		↕ ↑↑↑	↑↑↑	↕	↕ ↑↑↑		
Traffic Vol, veh/h	9	1	28	4	1	11	55	1758	7	24	1487	17
Future Vol, veh/h	9	1	28	4	1	11	55	1758	7	24	1487	17
Conflicting Peds, #/hr	0	0	0	0	0	0	0	0	0	0	0	0
Sign Control	Stop	Stop	Stop	Stop	Stop	Stop	Free	Free	Free	Free	Free	Free
RT Channelized	-	-	None	-	-	None	-	-	None	-	-	None
Storage Length	-	-	-	-	-	-	150	-	100	150	-	-
Veh in Median Storage, #	-	0	-	-	0	-	-	0	-	-	0	-
Grade, %	-	0	-	-	0	-	-	0	-	-	0	-
Peak Hour Factor	92	92	92	92	92	92	92	92	92	92	92	92
Heavy Vehicles, %	2	2	2	2	2	2	2	2	2	2	2	2
Mvmt Flow	10	1	30	4	1	12	60	1911	8	26	1616	18

Major/Minor	Minor2		Minor1		Major1		Major2					
Conflicting Flow All	2562	3716	817	2730	3717	956	1634	0	0	1919	0	0
Stage 1	1677	1677	-	2031	2031	-	-	-	-	-	-	-
Stage 2	885	2039	-	699	1686	-	-	-	-	-	-	-
Critical Hdwy	6.44	6.54	7.14	6.44	6.54	7.14	5.34	-	-	5.34	-	-
Critical Hdwy Stg 1	7.34	5.54	-	7.34	5.54	-	-	-	-	-	-	-
Critical Hdwy Stg 2	6.74	5.54	-	6.74	5.54	-	-	-	-	-	-	-
Follow-up Hdwy	3.82	4.02	3.92	3.82	4.02	3.92	3.12	-	-	3.12	-	-
Pot Cap-1 Maneuver	*156	*148	*567	*156	*148	*502	*713	-	-	*631	-	-
Stage 1	*582	*553	-	*515	*490	-	-	-	-	-	-	-
Stage 2	*515	*488	-	*582	*553	-	-	-	-	-	-	-
Platoon blocked, %	1	1	1	1	1	1	1	-	-	1	-	-
Mov Cap-1 Maneuver	*137	*130	*567	*133	*130	*502	*713	-	-	*631	-	-
Mov Cap-2 Maneuver	*137	*130	-	*133	*130	-	-	-	-	-	-	-
Stage 1	*533	*531	-	*472	*449	-	-	-	-	-	-	-
Stage 2	*459	*447	-	*527	*531	-	-	-	-	-	-	-

Approach	EB		WB		NB		SB	
HCM Control Delay, s	18.4		19.4		0.3		0.2	
HCM LOS	C		C					

Minor Lane/Major Mvmt	NBL	NBT	NBR	EBLn1	WBLn1	SBL	SBT	SBR
Capacity (veh/h)	* 713	-	-	310	268	* 631	-	-
HCM Lane V/C Ratio	0.084	-	-	0.133	0.065	0.041	-	-
HCM Control Delay (s)	10.5	-	-	18.4	19.4	11	-	-
HCM Lane LOS	B	-	-	C	C	B	-	-
HCM 95th %tile Q(veh)	0.3	-	-	0.5	0.2	0.1	-	-

Notes
 ~: Volume exceeds capacity \$: Delay exceeds 300s +: Computation Not Defined *: All major volume in platoon