



## Drainage Reports

# Gentry on the Green Preliminary Drainage Report

Job No. 19001704

Prepared for:

Owner:  
**COLRICH**  
444 WEST BEACH ST, STE. 300  
SAN DIEGO, CA 92101

Prepared by:

**Atwell, LLC**  
4700 E Southern Ave  
Mesa, AZ 85206



*Seth Jared Gardner*

June 2019



**GENTRY ON THE GREEN  
PRELIMINARY DRAINAGE REPORT  
TABLE OF CONTENTS**

|     |   |   |
|-----|---|---|
| 1.0 | INTRODUCTION/PROJECT DESCRIPTION.....               | 1 |
| 1.1 | PROJECT ADDRESS.....                                | 1 |
| 1.2 | GENERAL TOPOGRAPHY .....                            | 1 |
| 1.3 | PURPOSE .....                                       | 1 |
| 1.4 | EXISTING/ON-GOING STUDIES .....                     | 2 |
| 2.0 | FEMA FLOOD HAZARD ZONES .....                       | 2 |
| 3.0 | OFF-SITE ANALYSIS.....                              | 3 |
| 3.1 | EXISTING OFF-SITE FLOW CHARACTERISTICS.....         | 3 |
| 3.2 | PROPOSED OFF-SITE IMPROVEMENTS .....                | 4 |
| 4.0 | ON-SITE ANALYSIS .....                              | 4 |
| 4.1 | EXISTING ON-SITE FLOW CHARACTERISTICS.....          | 4 |
| 4.2 | METHODOLOGY AND CRITERIA .....                      | 4 |
| 4.3 | RETENTION REQUIREMENTS .....                        | 5 |
| 4.4 | SITE ULTIMATE OUTFALL .....                         | 6 |
| 4.5 | FINISHED FLOOR ELEVATIONS .....                     | 6 |
| 4.6 | STORM WATER QUALITY .....                           | 6 |
| 5.0 | STORM WATER POLLUTION PREVENTION PLAN (SWPPP) ..... | 7 |
| 6.0 | SUMMARY AND CONCLUSION.....                         | 8 |
| 7.0 | REFERENCES.....                                     | 9 |

## APPENDIX A

- EXHIBIT 1 – VICINITY MAP
- EXHIBIT 2 – FEMA FIRMETTE MAP
- EXHIBIT 3 – PRE-DEVELOPMENT DRAINAGE MAP
- EXHIBIT 4 – POST DEVELOPMENT DRAINAGE MAP

## APPENDIX B

- WEIGHTED AVERAGE RUNOFF COEFFICIENT CALCULATIONS
- EXHIBIT B.1 – PRE-DEVELOPMENT LAND USE AREAS
- EXHIBIT B.2 – POST-DEVELOPMENT LAND USE AREAS
- NOAA ATLAS 14 – POINT PRECIPITATION FREQUENCY ESTIMATES
- INDIAN BEND WASH FLOWMASTER CROSS SECTION ANALYSIS

## APPENDIX C

- EXCERPTS FROM FLO-2D WEB TOOL
- EXCERPTS FROM GENERAL DESIGN MEMORANDUM – PHASE 1, PLAN FORMULATION  
FOR INDIAN BEND WASH

## APPENDIX D

- STORM WATER QUALITY EXAMPLES



## **1.0 INTRODUCTION/PROJECT DESCRIPTION**

Gentry on the Green (“Project”) is a proposed Mixed-Use development within the jurisdiction of Scottsdale, Arizona. The Project lies within the southeast quarter of Section 23, Township 2 North, Range 4 East, of the Gila and Salt River Base and Meridian, Maricopa County, Arizona. More specifically the Project is located on the southwest corner of Camelback Road and Hayden Road. The current zoning is “R-5” and the current Land Use is “Urban Neighborhood”. The Project is proposing to demolish the existing structures on the property and construct new structures consisting of Multi-Family Residential, Commercial, Office and Retail uses.

### **1.1 PROJECT ADDRESS**

The Project area is currently the site of the Visconti at Camelback (7979 E Camelback Road) east of 78<sup>th</sup> Street and Cortesian Apartments (7749 E Camelback Road) west of 78<sup>th</sup> Street. A portion of the Visconti at Camelback Apartments has been recorded as “Indian Bend” (Book 248, Page 13, MCR). The Cortesian Apartment has been recorded as “Madeira Condominiums” (Book 223, Page 16, MCR).

### **1.2 GENERAL TOPOGRAPHY**

This area is an existing developed multi-family community. The area generally slopes to the east. Directly adjacent and defining the eastern boundary is Indian Bend Wash. The existing property east of 78<sup>th</sup> Street currently slopes toward and discharges directly into Indian Bend Wash. Property that lies west of 78<sup>th</sup> Street slopes toward and discharges directly into 78<sup>th</sup> street. These flows are conveyed to the south toward Glenrosa Avenue. These flows then follow Glenrosa Avenue to the east and ultimately discharge into Indian Bend Wash.

### **1.3 PURPOSE**

The purpose of this Preliminary Drainage Report is to support a re-zoning application that is required to support the proposed land plan. Preliminary drainage concepts are presented herein to provide sufficient information to indicate that the proposed improvement complies with the current City of Scottsdale requirements. This document has been prepared in accordance with Chapter 4 of the City of Scottsdale Design Standards and Policies Manual (DSPM) and the Flood Control District of Maricopa County Drainage Design Manuals.

#### **1.4 EXISTING/ON-GOING STUDIES**

To the east of the Project is Indian Bend Wash. Indian Bend Wash is a conveyance system that drains significant portions of the North Scottsdale and North Phoenix area. Due to the significance of this wash, multiple studies have been conducted on this wash. Per the City of Scottsdale Code, Section 37-22, developments in the Indian Bend Wash area are required to consider a study by the U.S. Army Corps of Engineers (USACOE) entitled, in part, General Design Memorandum – Phase 1, Plan Formulation for Indian Bend Wash, dated October 1973. More recently, the City of Scottsdale, in conjunction with the Flood Control District of Maricopa County (FCD) have updated the Lower Indian Bend Wash Area Drainage Master Study (LIBW ADMS). This study utilized a modeling program named FLO-2D. Results from the FLO-2D program have been published by the FCD through their GIS based FLO-2D Web Tool. This study generally quantifies the flows in the area of Indian Bend Wash.

#### **2.0 FEMA FLOOD HAZARD ZONES**

The Project is located on Federal Emergency Management Agency (FEMA) National Flood Insurance Program (NFIP), Flood Insurance Rate Map (FIRM) No. 04013C1770L and 04013C2235L (See Exhibit 1), revised October 16, 2013. The Project is located in Flood Hazard Zone “X” and Zone “X” Shaded. Flood Zone “X” is defined as follows:

Area of Minimal Flooding

Flood Zone “X” Shaded is defined as follows:

0.2% Annual Change Flood Hazard, Areas of 1% annual chance flood with average depth less than one foot or with drainage areas of less than one square mile.

Indian Bend Wash lies within a Flood Hazard Zone AE which is defined as areas subject to inundation by the 1-percent-annual-chance flood event determined by detailed methods. Base Flood Elevations (BFEs) are shown.

Proposed finished floors are designed to maintain at least 1-foot freeboard above these BFE’s.

### **3.0 OFF-SITE ANALYSIS**

#### **3.1 EXISTING OFF-SITE FLOW CHARACTERISTICS**

Detailed studies have been conducted in the vicinity of this project. Results from previous studies were used to determine offsite flows. The LIBW ADMS describes in detail the flow characteristics surrounding the Project. The Project area and the surrounding properties generally slope toward Indian Bend Wash, to the east. Camelback Road is fully developed with curb and gutter. There is a storm drain system on the south side of Camelback Road that conveys storm water from the west to Indian Bend Wash.

According to the LIBW ADMS, Indian Bend Wash conveys approximately 19,000 cfs. The majority of these flows are conveyed east of Hayden Road in the Indian Bend Wash Overflow Channel. The portion of Indian Bend Wash adjacent to the Project is considered the Indian Bend Wash Low Flow channel and conveys approximately 3,000 cfs. The LIBW ADMS determined the 100-year, 6-hour storm High Water Elevation (HWE) though the wash. These elevations are shown on Exhibit 3 in the Appendix of this report.

The LIBW ADMS FLO-2D analysis indicates that a portion of the flows on Camelback Road are diverted and conveyed south along 78<sup>th</sup> Street. These diverted flows are estimated to be approximately 53 cfs. These flows are conveyed within 78<sup>th</sup> Street toward Glenrosa Avenue, where they eventually enter into the Indian Bend Wash. Excerpts from the Flood Control District of Maricopa County FLO-2D Web Tool program is included in Appendix C of this report.

In 1973 the United States Army Corps of Engineers (USACOE) prepared a document entitled, in part, General Design Memorandum – Phase 1, Plan Formulation for Indian Bend Wash, dated October 1973 (ACOE Report). In this document Indian Bend Wash was studied and high water elevations were estimated. Peak flows in Indian Bend Wash (low flow channel and Overflow channel) are estimated to be 27,000 cfs with 30,000 cfs as a design value used by Scottsdale as part of the flood plain management criteria. See Appendix C for the water surface profile that was determined in the ACOE Report.

In evaluation of the results of the FLO-2D model and the ACOE results a few items should be noted. The FLO-2D results indicate an approximate flow of 19,000cfs in the Indian Bend Wash system, significantly lower than that of the ACOE study. The FLO-2D results indicate that Hayden Road creates a split flow system, with excess from the Indian Bend Low Flow channel overtopping Hayden

Road and combining with the flows in the Indian Bend Overflow Channel. In the FLO-2D model the overflow channel ranges from 1.25 feet to 1.45 feet below the low flow channel. With these observations noted, a cross section was analyzed using the design value of 30,000cfs. The FlowMaster V8i program was used to determine the estimated water surface elevation. FlowMaster assumed a constant water surface elevation across the section. Results of the FlowMaster program are included in Appendix B of this report. As these results indicate an estimated water surface elevation lower than the FLO-2D study, the proposed buildings finished floors will be placed well above this estimated water surface elevation.

No offsite flows are anticipated to impact this site.

### **3.2 PROPOSED OFF-SITE IMPROVEMENTS**

This project does not propose any improvements to the current off-site drainage characteristics. Reasonable care will be taken during final design to maintain existing flow patterns in and around the project site.

## **4.0 ON-SITE ANALYSIS**

### **4.1 EXISTING ON-SITE FLOW CHARACTERISTICS**

The current site does not provide for any on-site retention. Flows from the Project site are conveyed to adjacent streets or directly into Indian Bend Wash. Exhibit 3 – Pre-Development Drainage Map illustrates the estimated drainage patterns found within the development area.

### **4.2 METHODOLOGY AND CRITERIA**

Runoff from the proposed improvements will maintain similar flow patterns as compared to the pre-development conditions. Runoff will be directed to adjacent streets or into Indian Bend Wash. Areas exposed to vehicular traffic and other sources of possible contaminants will have water quality measures in-line to ensure runoff is treated prior to exiting the site. Runoff from areas not exposed to contaminants (ie. roof drains, interior courtyards etc.) will be allowed to convey directly into adjacent streets or Indian Bend Wash without being treated.

For Phase 1 of the Project, the proposed improvements include a storm drain system that will collect runoff from around the Project and convey the flows toward Indian Bend Wash. The Rational Method will be used to calculate 10-year and 100-year peak flows for each inlet. The storm drain system will be designed to convey the peak 100-year flows below the inlet grade. Peak flow calculation

and storm drain analysis will be included in subsequent reports. Exhibit 4 – Post-Development Drainage Map illustrates the conceptual drainage patterns for the improvements.

Phase 2 of the Project will follow similar drainage criteria, with the exception of a storm drain system connection to Indian Bend Wash. It is anticipated that surface flow will be treated via surface basins or similar prior to entering the adjacent streets. In the existing conditions, the area west of 78th Street flows directly into 78<sup>th</sup> Street. This same discharge location will be utilized with the Phase 2 development.

### **4.3 RETENTION REQUIREMENTS**

Both Visconti at Camelback and Cortesian Apartments were constructed prior to 1987. As such, the City of Scottsdale DSPM requires these sites to retain the difference between the Pre-Development condition and the Post-Development condition. The Project site was analyzed in the Pre-Development condition and the Post-Development condition to determine a weighted average runoff coefficient for each. Runoff coefficients were selected for Rooftops ( $C_{10yr}=0.85$ ), Asphalt/Concrete ( $C_{10yr}=0.85$ ), and Openspace ( $C_{10yr}=0.50$ ), in accordance with Table 3.2 – Runoff Coefficients for Maricopa County from the Drainage Design Manual for Maricopa County – Hydrology (DDM – Hydrology). Areas for the Pre-Development condition were developed from aerial imagery, ground survey and site visits. Areas for the Post-Developed condition were taken from the most recent version of the proposed site plan. Runoff coefficients for each land use category were held constant between Pre and Post conditions. Land Use area maps and Weighted Average Runoff Coefficient calculations can be found in Appendix B of this report. The total runoff volume for the site is calculated according to the following equation:

$$V = \Delta C \times (P/12) \times A$$

Where:  $V$  = Total Runoff Volume (cubic feet)  
 $\Delta C$  = Increase in Weighted Runoff coefficient ( $C_{post} - C_{pre}$ )  
 $P$  = 100-year 2-hour precipitation depth (inches)  
 $A$  = Drainage Area (sf).

For determining the precipitation depth, the NOAA Atlas 14 Data Server was used. The precipitation for the Project for a 100-year, 2-hour storm is 2.17 inches. (See the Appendix B for NOAA 14 information).

It was found in the pre vs. post development condition comparison that the post development will produce a lower volume of runoff than the current conditions. Therefore, this site will not be required to retain any storm water.

#### **4.3.1 DISSIPATION OF STORED RUNOFF**

The City of Scottsdale requires that any retained/detained storm water be drained within 36-hours. It is not anticipated that this site will incorporate any retention/detention facilities, as discussed previously. However, it is anticipated that any retained/detained storm water will be drained into Indian Bend Wash via orifice plates. Further detail will be developed in subsequent reports.

#### **4.4 SITE ULTIMATE OUTFALL**

During greater-than-design or back-to-back storm events, excess storm water will overflow to adjacent streets or Indian Bend Wash. Excess water will leave the site at different locations where it will discharge into the Camelback Road, 78th Street, Parkway Avenue or Indian Bend Wash, in accordance with the historical flow patterns. The site ultimate outfall for Phase 1 is located in the southeast corner of the site along Indian Bend Wash at an elevation of 1244 (NAVD 88). The site ultimate outfall for Phase 2 is located in the southeast corner of the site along 78th Street at an elevation of 1247 (NAVD 88). See Exhibit 4 – Post-Development Drainage Exhibit in Appendix A for outfall elevations and locations.

#### **4.5 FINISHED FLOOR ELEVATIONS**

The proposed finished floors were set in consideration of the site ultimate outfall elevation and the 100-year high water elevation within Indian Bend Wash. Finished floors are set to ensure at least 1-foot of freeboard above the LIBW ADMS WSE in Indian Bend Wash and at least 1-foot above the site ultimate outfall. Furthermore, finished floors are set to ensure they are above the water surface elevation established in the Phase 1, Plan Formulation for Indian Bend Wash, prepared by the USACOE, dated October 1973.

#### **4.6 STORM WATER QUALITY**

Portions of the site exposed to vehicular traffic or other sources of possible surface run-off pollutants will incorporate some type of in-line water quality device. Low impact development measures are anticipated to be utilized throughout the site, where ever practical. Some of these measures may include permeable pavements (pavers and/or concrete), vegetated or rock bioswales, shallow bioretention systems, bioretention planters, sediment traps, inlet liners

and in-line storm water quality units. Examples of these measures are provided in Appendix D of this report.

## **5.0 STORM WATER POLLUTION PREVENTION PLAN (SWPPP)**

It is the responsibility of the contractor to remain compliant with all NPDES regulations during the construction period. A SWPPP is provided with the final construction documents.

## **6.0 SUMMARY AND CONCLUSION**

This preliminary drainage report provides sufficient information to conclude that the proposed development complies with City of Scottsdale Design Standards and Policies Manual and the Flood Control District of Maricopa County drainage design standards. This study has determined the following:

- No off-site flows impact this site
- The proposed improvements will maintain the historical discharge locations
- This site will not increase storm water runoff, therefore this site is not responsible for any storm water storage
- The proposed project will not increase peak flows exiting the site
- Storm water discharges will be treated to ensure current storm water quality standards
- All finished floor elevations are set a minimum of 1-foot above the adjacent 100-year water surface elevation and/or the site ultimate outfall
- Phase 2 (West of 78<sup>th</sup> Ave) will be designed to maintain these same design criteria.



## **7.0 REFERENCES**

1. Flood Control District of Maricopa County (August 2013). *Drainage Design Manual for Maricopa County, Arizona, Hydraulics*. Phoenix, Arizona
2. Flood Control District of Maricopa County (February 2011). *Drainage Design Manual for Maricopa County, Arizona, Hydrology*. Phoenix, Arizona
3. City of Scottsdale (2018). *Design Standards and Policies Manual (DSPM)*, Scottsdale, Arizona
4. Gaven and Barker, Inc, (December 2017). *Lower Indian Bend Wash Area Drainage Master Study – Hydrology & Hydraulics Report*. Phoenix, Arizona
5. United State Army Corps of Engineers, (October 1973). *Gila River Basin, Arizona Indian Bend Wash Design Memorandum No. 1, General Design Memorandum – Phase 1 Plan Formulation for Indian Bend Wash*. Los Angeles, California
6. Flood Control District of Maricopa County, (2019) FLO-2D Web Tool, <https://gis.maricopa.gov/flo-2dModels/>
7. City of Scottsdale, (2019) *Greater Phoenix Metro Green Infrastructure Handbook - Low-Impact Development Details for Alternative Stormwater Management*, Scottsdale, Arizona

## APPENDIX A

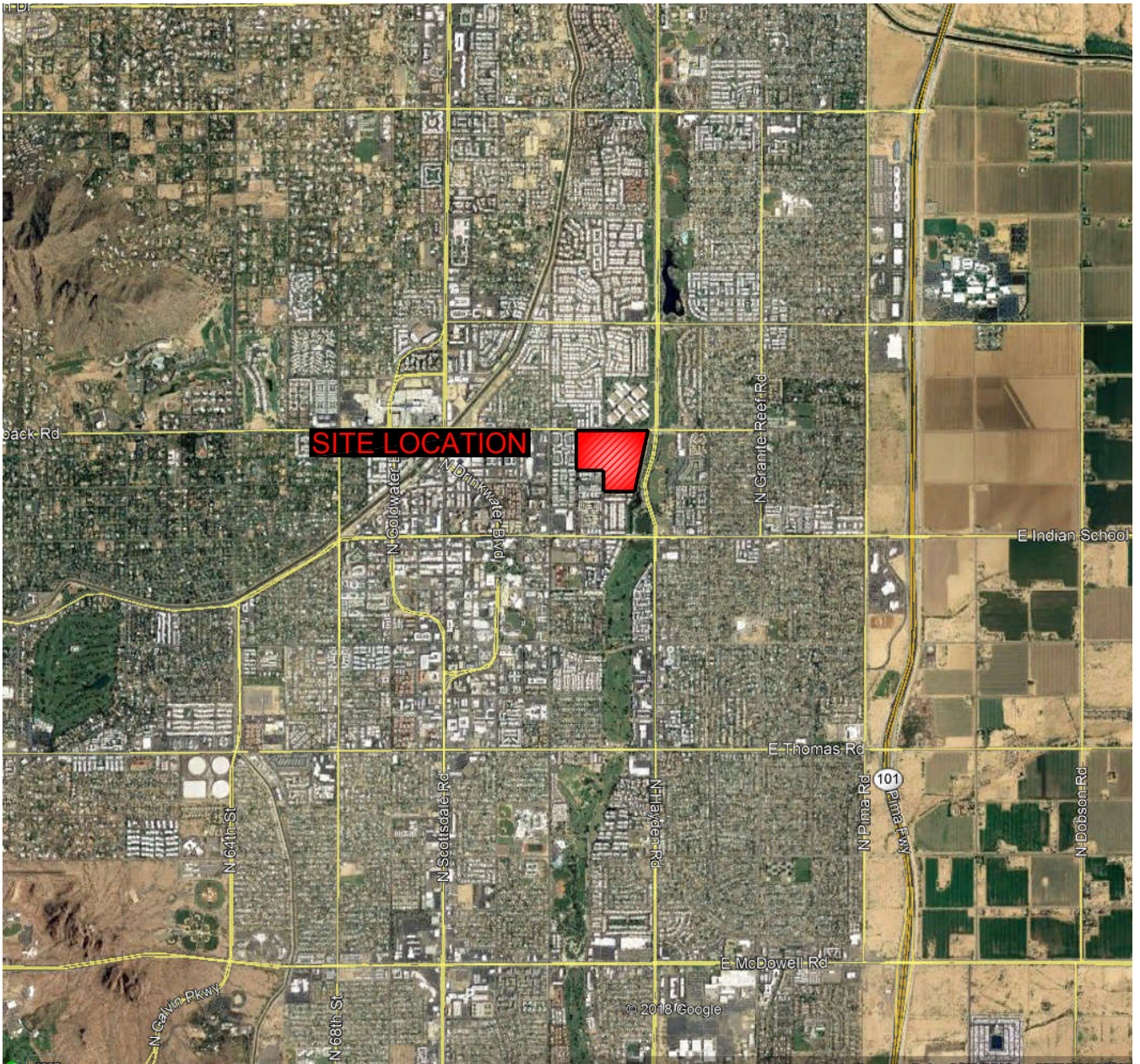
EXHIBIT 1 – VICINITY MAP

EXHIBIT 2 – FEMA FIRMETTE MAP

EXHIBIT 3 – PRE-DEVELOPMENT DRAINAGE MAP

EXHIBIT 4 – POST-DEVELOPMENT DRAINAGE MAP

k:\19001704\project\_documents\engineering-planning-power\_and\_energy\reports\water\exhibits\19001704 - exh. 1 vicinity map.dwg Saved: 5/16/2019 12:59 PM Plot date: 5/16/2019 12:59 PM



### LEGEND

GENTRY ON THE GREEN



# ATWELL

866.850.4200 [www.atwell-group.com](http://www.atwell-group.com)

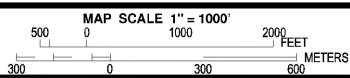
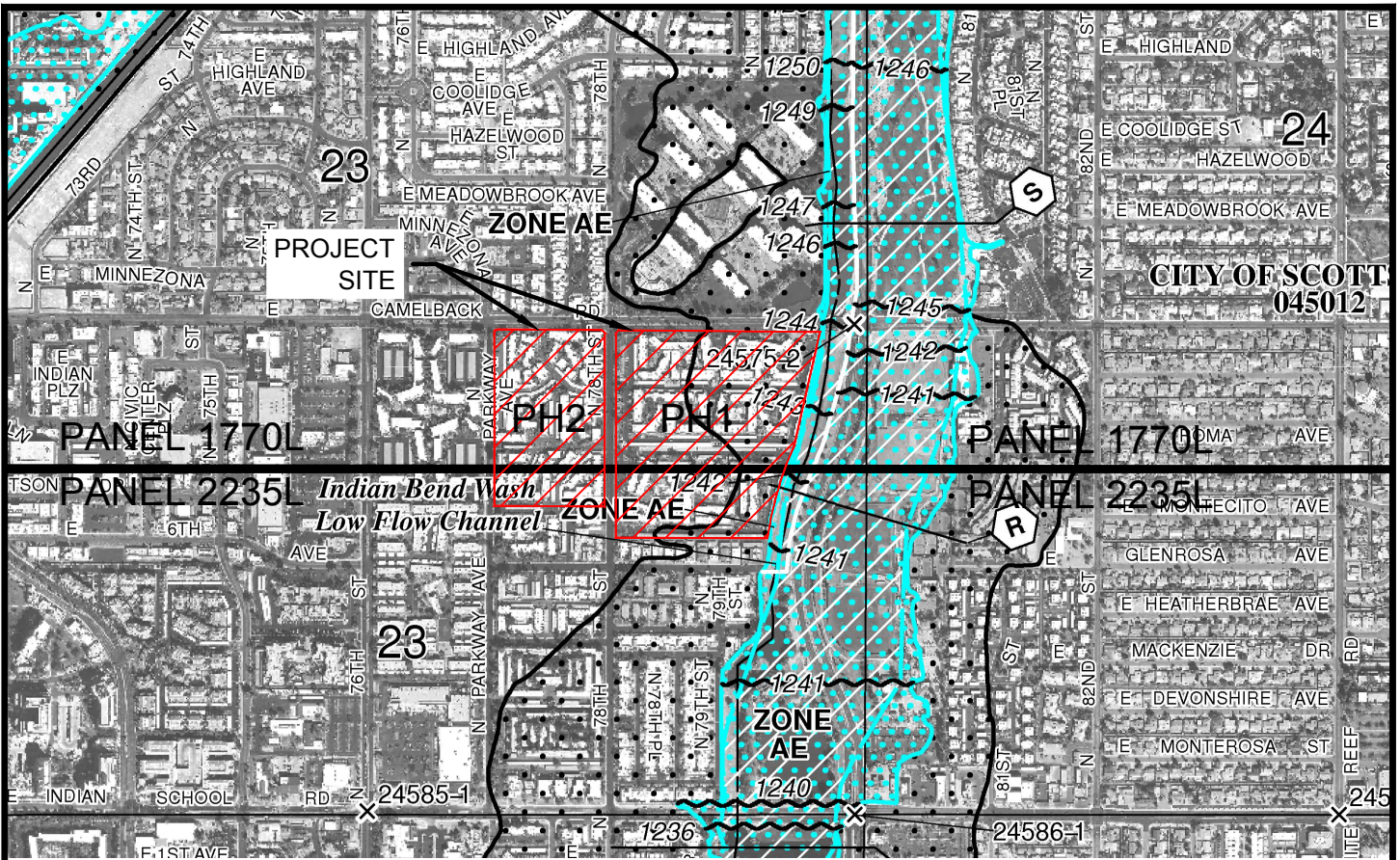
4700 E. SOUTHERN AVENUE  
MESA, AZ 85206  
480.218.8831

## EXHIBIT 1 - VICINITY MAP

### GENTRY ON THE GREEN

SCOTTSDALE, AZ





**NFIP** PANEL 1770L

**FIRM**  
FLOOD INSURANCE RATE MAP  
MARICOPA COUNTY,  
ARIZONA  
AND INCORPORATED AREAS

**PANEL 1770 OF 4425**  
(SEE MAP INDEX FOR FIRM PANEL LAYOUT)

**CONTAINS:**

| COMMUNITY               | NUMBER | PANEL | SUFFIX |
|-------------------------|--------|-------|--------|
| MARICOPA COUNTY         | 040037 | 1770  | L      |
| PARADISE VALLEY TOWN OF | 040049 | 1770  | L      |
| SCOTTSDALE, CITY OF     | 045012 | 1770  | L      |

Notice to User: The Map Number shown below should be used when placing map orders; the Community Number shown above should be used on insurance applications for the subject community.

**MAP NUMBER**  
04013C1770L  
**MAP REVISED**  
OCTOBER 16, 2013

Federal Emergency Management Agency

**NFIP** PANEL 2235L

**FIRM**  
FLOOD INSURANCE RATE MAP  
MARICOPA COUNTY,  
ARIZONA  
AND INCORPORATED AREAS

**PANEL 2235 OF 4425**  
(SEE MAP INDEX FOR FIRM PANEL LAYOUT)

**CONTAINS:**

| COMMUNITY           | NUMBER | PANEL | SUFFIX |
|---------------------|--------|-------|--------|
| MARICOPA COUNTY     | 040037 | 2235  | L      |
| MESA, CITY OF       | 040048 | 2235  | L      |
| SCOTTSDALE, CITY OF | 045012 | 2235  | L      |
| TEMPE, CITY OF      | 040054 | 2235  | L      |

Notice to User: The Map Number shown below should be used when placing map orders; the Community Number shown above should be used on insurance applications for the subject community.

**MAP NUMBER**  
04013C2235L  
**MAP REVISED**  
OCTOBER 16, 2013

Federal Emergency Management Agency

**LEGEND**

SPECIAL FLOOD HAZARD AREAS (SFHAs) SUBJECT TO INUNDATION BY THE 1% ANNUAL CHANCE FLOOD

The 1% annual chance flood (100-year flood), also known as the base flood, is the flood that has a 1% chance of being equaled or exceeded in any given year. The Special Flood Hazard Area is the area subject to flooding by the 1% annual chance flood. Areas of Special Flood Hazard include Zones A, AE, AH, AO, AR, A99, V and VE. The Base Flood Elevation is the water-surface elevation of the 1% annual chance flood.

**ZONE A** No Base Flood Elevations determined.  
**ZONE AE** Base Flood Elevations determined.  
**ZONE AH** Flood depths of 1 to 3 feet (usually areas of ponding); Base Flood Elevations determined.  
**ZONE AO** Flood depths of 1 to 3 feet (usually sheet flow on sloping terrain); average depths determined. For areas of alluvial fan flooding, velocities also determined.  
**ZONE AR** Special Flood Hazard Area formerly protected from the 1% annual chance flood by a flood control system that was subsequently decertified. Zone AR indicates that the former flood control system is being restored to provide protection from the 1% annual chance or greater flood.  
**ZONE A99** Area to be protected from 1% annual chance flood by a Federal flood protection system under construction; no Base Flood Elevations determined.  
**ZONE V** Coastal flood zone with velocity hazard (wave action); no Base Flood Elevations determined.  
**ZONE VE** Coastal flood zone with velocity hazard (wave action); Base Flood Elevations determined.

FLOODWAY AREAS IN ZONE AE

The floodway is the channel of a stream plus any adjacent floodplain areas that must be kept free of encroachment so that the 1% annual chance flood can be carried without substantial increases in flood heights.

**OTHER FLOOD AREAS**

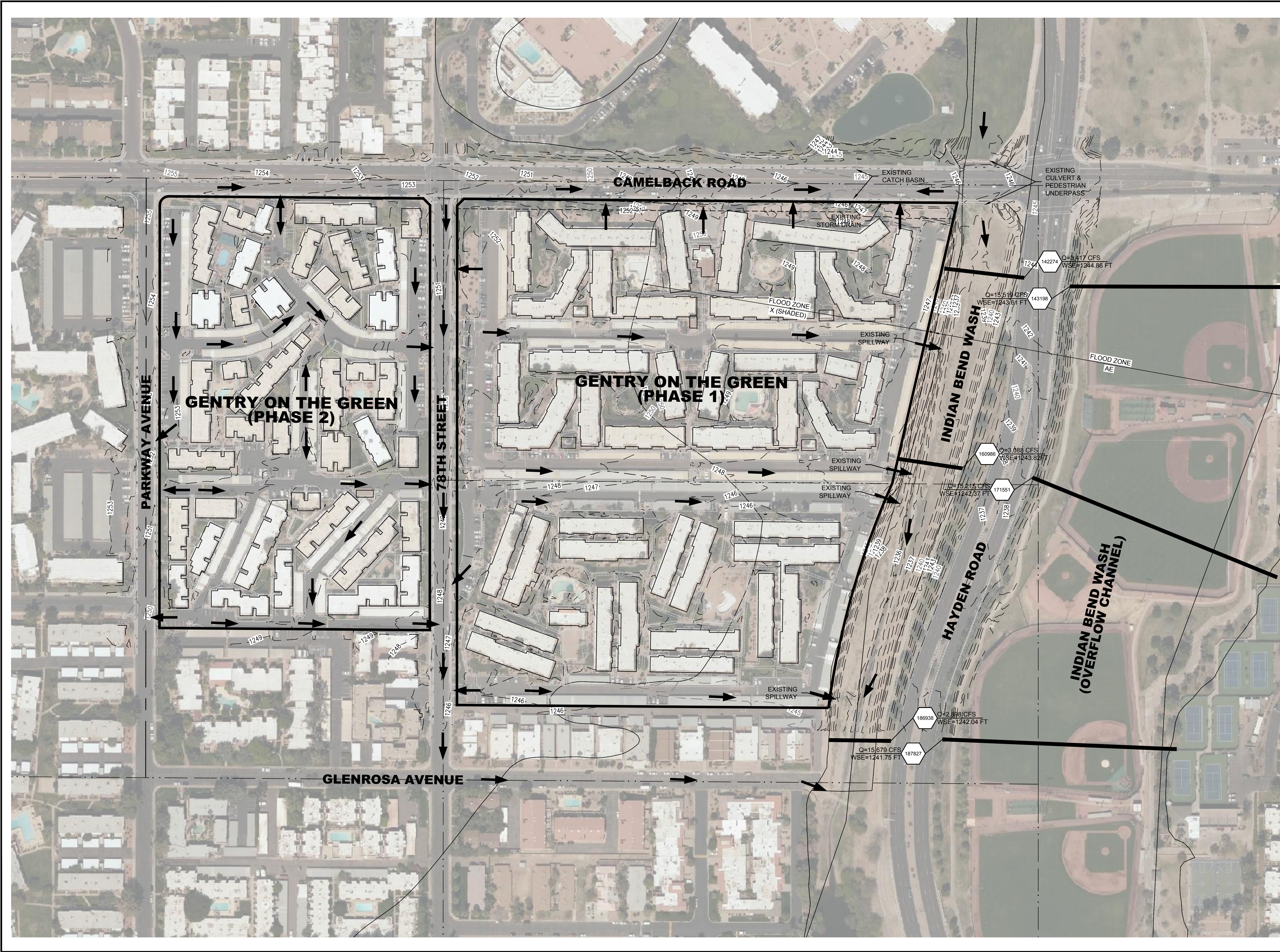
**ZONE X** Areas of 0.2% annual chance flood; areas of 1% annual chance flood with average depths of less than 1 foot or with drainage areas less than 1 square mile; and areas protected by levees from 1% annual chance flood.

**OTHER AREAS**

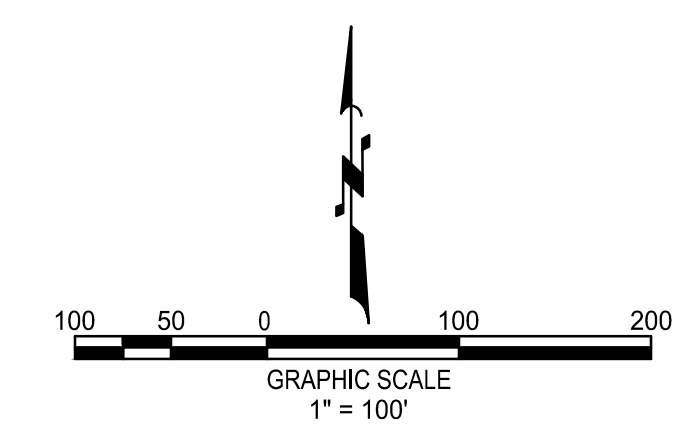
**ZONE X** Areas determined to be outside the 0.2% annual chance floodplain.  
**ZONE D** Areas in which flood hazards are undetermined, but possible.

**EXHIBIT 3**  
**FEMA FIRM**  
**GENTRIFY ON THE GREEN**





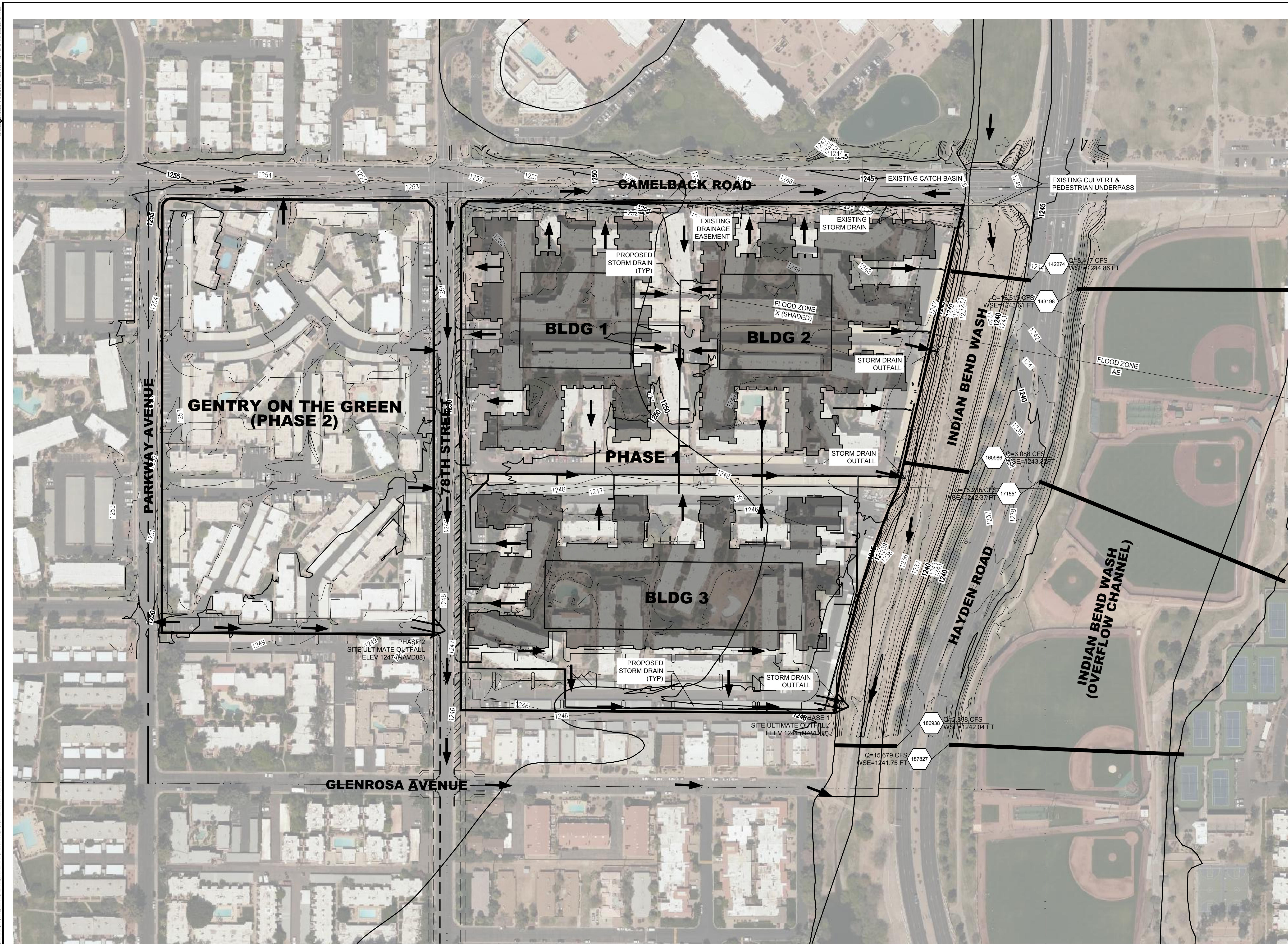
- LEGEND**
- PROJECT AREA BOUNDARY
  - LOWER INDIAN BEND WASH ADMP CROSS SECTION ID
  - DIRECTION OF FLOW
  - FEMA FLOOD ZONE BOUNDARY



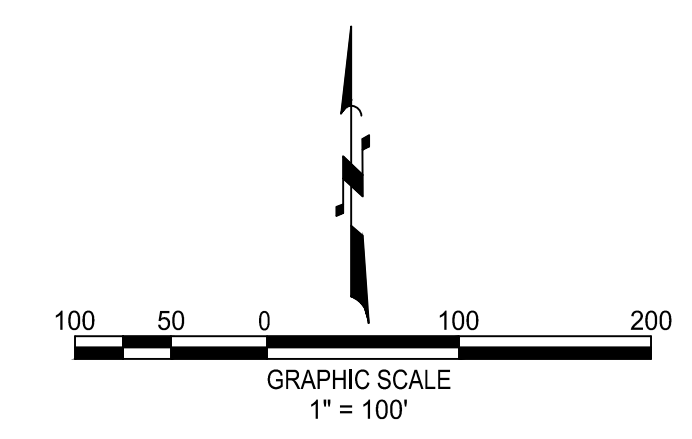
**EXHIBIT 3**  
 NOT FOR CONSTRUCTION  
 GENTRY ON THE GREEN  
 PRE-DEVELOPMENT DRAINAGE EXHIBIT  
 SCOTTSDALE, ARIZONA

**ATWELL**  
 800.850.4500 [www.atwell-group.com](http://www.atwell-group.com)  
 4700 E. SOUTHWEST AVENUE  
 MESA, AZ 85208  
 602.941.9501





- LEGEND**
- PROJECT AREA BOUNDARY
  - LOWER INDIAN BEND WASH ADMP CROSS SECTION ID
  - DIRECTION OF FLOW
  - FEMA FLOOD ZONE BOUNDARY



**EXHIBIT 4**  
 NOT FOR CONSTRUCTION  
 GENTRY ON THE GREEN  
 POST-DEVELOPMENT DRAINAGE EXHIBIT  
 SCOTTSDALE, ARIZONA





## APPENDIX B

WEIGHTED AVERAGE RUNOFF COEFFICIENT CALCULATIONS

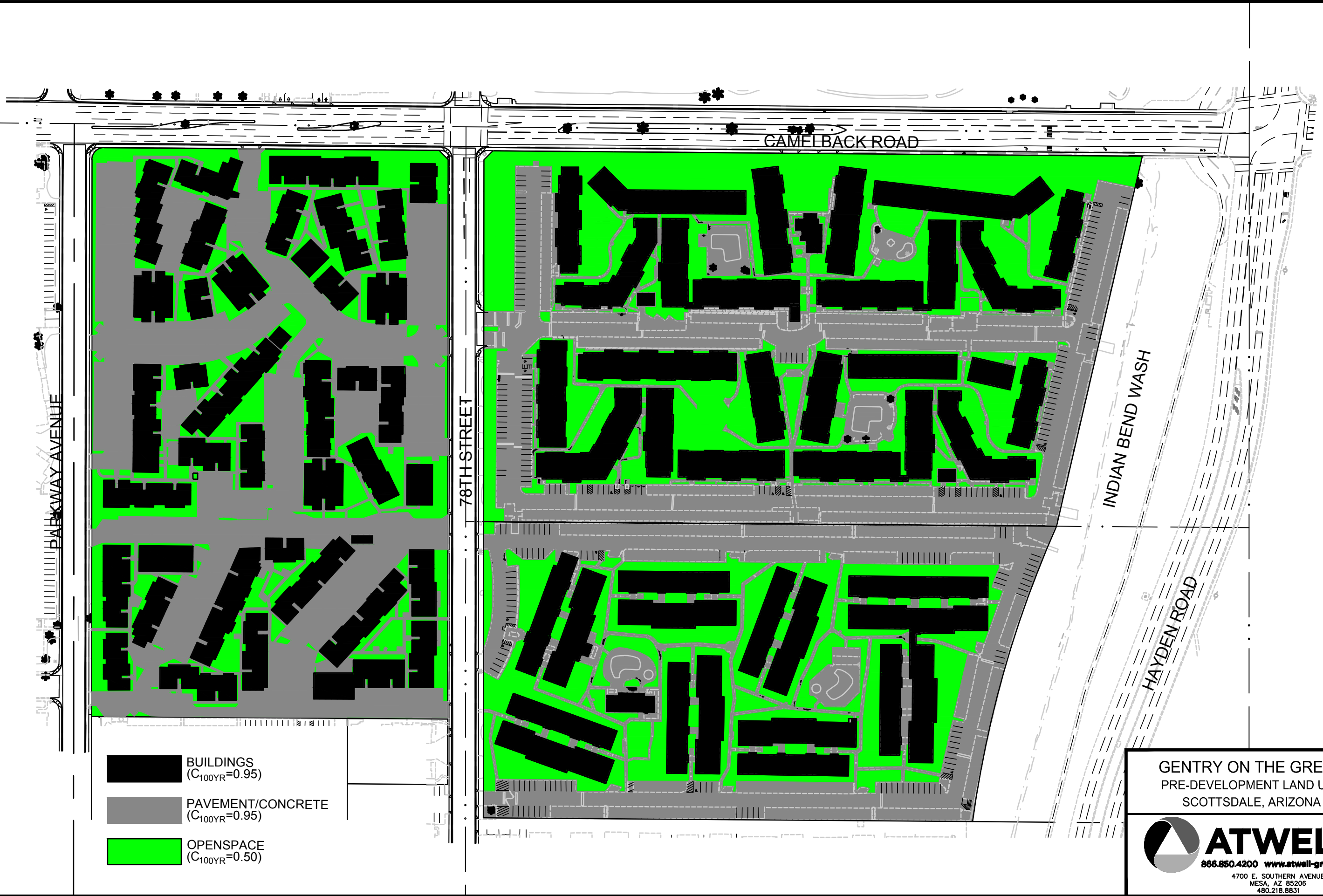
EXHIBIT B.1 – PRE-DEVELOPMENT LAND USE AREAS




EXHIBIT B.2 – POST-DEVELOPMENT LAND USE AREAS

NOAA ATLAS 14 – POINT PRECIPITATION FREQUENCY ESTIMATES

INDIAN BEND WASH FLOWMASTER CROSS SECTION ANALYSIS

Copyright © 2016 Atwell. No reproduction shall be made without the prior written consent of Atwell.  
I:\1800704\project\_documents\engineering\planning-power and energy\reports\1800704-predev\_land\_use\1800704-predev\_land\_use.dwg 5/20/2019 4:34 PM Plotted: 5/20/2019 4:34 PM



-  BUILDINGS  
( $C_{100YR}=0.95$ )
-  PAVEMENT/CONCRETE  
( $C_{100YR}=0.95$ )
-  OPENSACE  
( $C_{100YR}=0.50$ )

GENTRY ON THE GREEN  
PRE-DEVELOPMENT LAND USE  
SCOTTSDALE, ARIZONA



**ATWELL**  
866.850.4200 [www.atwell-group.com](http://www.atwell-group.com)  
4700 E. SOUTHERN AVENUE  
MESA, AZ 85206  
480.218.8831





# WEIGHTED RUNOFF COEFFICIENT

**Project:** Gentry on the Green - Phase 1

**Description:** City of Scottsdale

Date: 5/30/2019

**Prepared by:** Jared G.

Atwell Project #: 19001704

Objective: Compute weighted Average Runoff Coefficient.

Equations:

$$C_w = \frac{A_1 C_1 + A_2 C_2 + \dots + A_n C_n}{A_1 + A_2 + \dots + A_n}$$

## 100-yr Weighted Coefficient

Phase 1 Pre-Development Conditions

| Sub Area Type                                    | Area (Sq. Ft.)   | 100-yr Runoff Coefficient | AC             |
|--|------------------|---------------------------|----------------|
| Rooftop  | 326,667          | 0.95                      | 310,334        |
| Asphalt/Concrete                                 | 409,116          | 0.95                      | 388,660        |
| Openspace  | 341,510          | 0.50                      | 170,755        |
| <b>Totals</b>                                    | <b>1,077,293</b> |                           | <b>869,749</b> |
| <b><math>C_w = \Sigma AC / \Sigma A =</math></b> |                  |                           | <b>0.81</b>    |

## 100-yr Weighted Coefficient

Phase 1 Post-Development Conditions

| Sub Area Type                                    | Area (Sq. Ft.)   | 100-yr Runoff Coefficient | AC             |
|--|------------------|---------------------------|----------------|
| Rooftop  | 523,424          | 0.95                      | 497,253        |
| Asphalt/Concrete                                 | 172,846          | 0.95                      | 164,204        |
| Permeable Pvmt*                                  | 94,837           | 0.30                      | 28,451         |
| Openspace  | 286,186          | 0.50                      | 143,093        |
| <b>Totals</b>                                    | <b>1,077,293</b> |                           | <b>833,001</b> |
| <b><math>C_w = \Sigma AC / \Sigma A =</math></b> |                  |                           | <b>0.77</b>    |

\*See Permeable Interlocking Concrete Pavement (PICP) Design Professionals Fact Sheet (Attached)



**NOAA Atlas 14, Volume 1, Version 5**  
**Location name: Scottsdale, Arizona, USA\***  
**Latitude: 33.5008°, Longitude: -111.9114°**  
**Elevation: 1242.49 ft\*\***



\* source: ESRI Maps  
 \*\* source: USGS

**POINT PRECIPITATION FREQUENCY ESTIMATES**

Sanja Perica, Sarah Dietz, Sarah Heim, Lillian Hiner, Kazungu Maitaria, Deborah Martin, Sandra Pavlovic, Ishani Roy, Carl Trypaluk, Dale Unruh, Fenglin Yan, Michael Yekta, Tan Zhao, Geoffrey Bonnin, Daniel Brewer, Li-Chuan Chen, Tye Parzybok, John Yarchoan

NOAA, National Weather Service, Silver Spring, Maryland

[PF\\_tabular](#) | [PF\\_graphical](#) | [Maps\\_&\\_aerials](#)

**PF tabular**

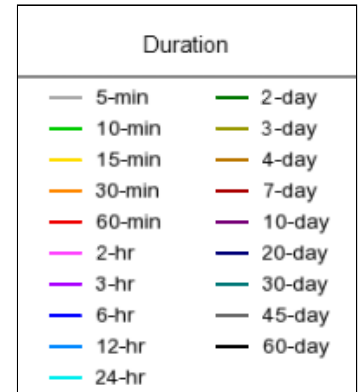
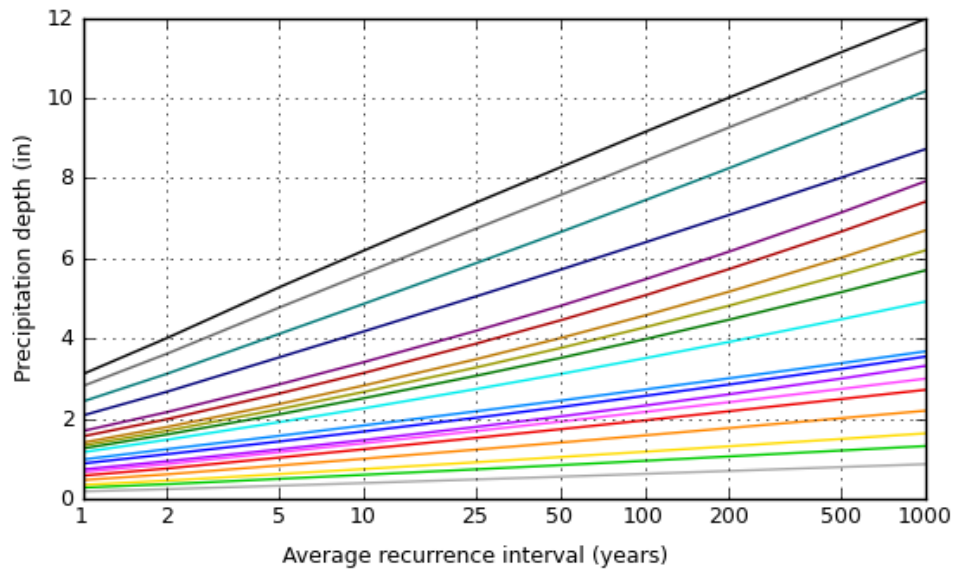
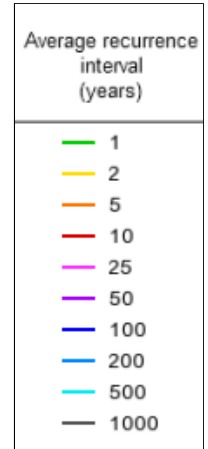
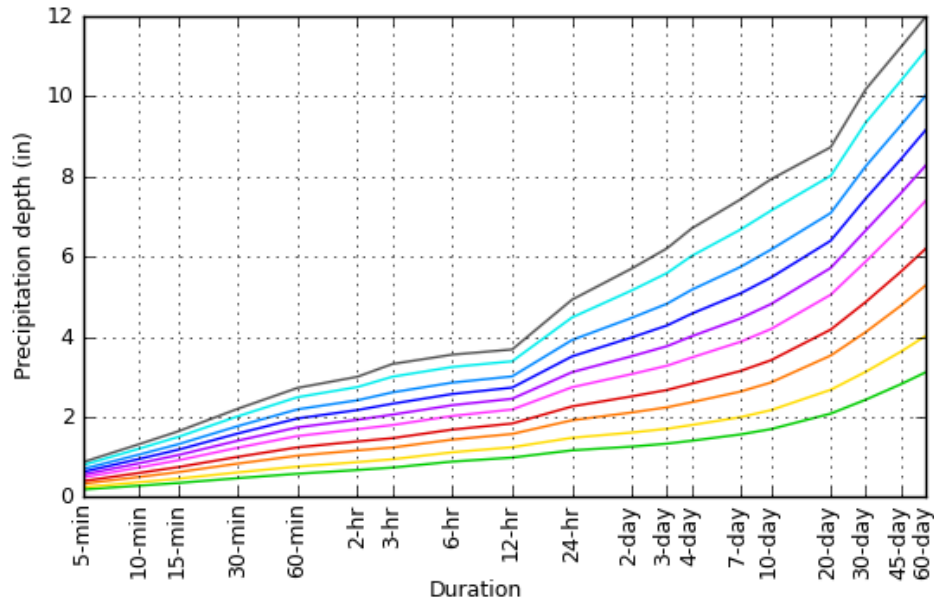
| <b>PDS-based point precipitation frequency estimates with 90% confidence intervals (in inches)<sup>1</sup></b> |  |                               |                               |                               |                               |                               |                               |                               |                               |                              |
|--|--|-------------------------------|-------------------------------|-------------------------------|-------------------------------|-------------------------------|-------------------------------|-------------------------------|-------------------------------|------------------------------|
| <b>Duration</b>  | <b>Average recurrence interval (years)</b> |                               |                               |                               |                               |                               |                               |                               |                               |                              |
|  | <b>1</b>                                   | <b>2</b>                      | <b>5</b>                      | <b>10</b>                     | <b>25</b>                     | <b>50</b>                     | <b>100</b>                    | <b>200</b>                    | <b>500</b>                    | <b>1000</b>                  |
| <b>5-min</b>   | <b>0.184</b><br>(0.154-0.225)              | <b>0.241</b><br>(0.202-0.294) | <b>0.327</b><br>(0.273-0.398) | <b>0.393</b><br>(0.326-0.475) | <b>0.483</b><br>(0.394-0.581) | <b>0.552</b><br>(0.445-0.661) | <b>0.623</b><br>(0.492-0.744) | <b>0.695</b><br>(0.540-0.829) | <b>0.792</b><br>(0.599-0.945) | <b>0.865</b><br>(0.642-1.03) |
| <b>10-min</b>  | <b>0.280</b><br>(0.235-0.342)              | <b>0.366</b><br>(0.308-0.447) | <b>0.498</b><br>(0.415-0.605) | <b>0.599</b><br>(0.496-0.724) | <b>0.735</b><br>(0.599-0.884) | <b>0.840</b><br>(0.677-1.01)  | <b>0.948</b><br>(0.749-1.13)  | <b>1.06</b><br>(0.822-1.26)   | <b>1.21</b><br>(0.911-1.44)   | <b>1.32</b><br>(0.977-1.58)  |
| <b>15-min</b>  | <b>0.347</b><br>(0.291-0.424)              | <b>0.454</b><br>(0.382-0.554) | <b>0.617</b><br>(0.515-0.750) | <b>0.742</b><br>(0.615-0.897) | <b>0.911</b><br>(0.743-1.10)  | <b>1.04</b><br>(0.839-1.25)   | <b>1.18</b><br>(0.928-1.40)   | <b>1.31</b><br>(1.02-1.56)    | <b>1.49</b><br>(1.13-1.78)    | <b>1.63</b><br>(1.21-1.95)   |
| <b>30-min</b>  | <b>0.467</b><br>(0.392-0.571)              | <b>0.611</b><br>(0.514-0.746) | <b>0.831</b><br>(0.693-1.01)  | <b>0.999</b><br>(0.828-1.21)  | <b>1.23</b><br>(1.00-1.48)    | <b>1.40</b><br>(1.13-1.68)    | <b>1.58</b><br>(1.25-1.89)    | <b>1.77</b><br>(1.37-2.11)    | <b>2.01</b><br>(1.52-2.40)    | <b>2.20</b><br>(1.63-2.63)   |
| <b>60-min</b>  | <b>0.578</b><br>(0.485-0.706)              | <b>0.757</b><br>(0.636-0.923) | <b>1.03</b><br>(0.858-1.25)   | <b>1.24</b><br>(1.02-1.50)    | <b>1.52</b><br>(1.24-1.83)    | <b>1.74</b><br>(1.40-2.08)    | <b>1.96</b><br>(1.55-2.34)    | <b>2.19</b><br>(1.70-2.61)    | <b>2.49</b><br>(1.88-2.97)    | <b>2.72</b><br>(2.02-3.26)   |
| <b>2-hr</b>  | <b>0.671</b><br>(0.571-0.802)              | <b>0.868</b><br>(0.738-1.04)  | <b>1.16</b><br>(0.984-1.39)   | <b>1.39</b><br>(1.16-1.65)    | <b>1.69</b><br>(1.40-2.00)    | <b>1.93</b><br>(1.58-2.27)    | <b>2.17</b><br>(1.75-2.56)    | <b>2.41</b><br>(1.91-2.84)    | <b>2.74</b><br>(2.12-3.24)    | <b>3.00</b><br>(2.27-3.56)   |
| <b>3-hr</b>  | <b>0.732</b><br>(0.620-0.884)              | <b>0.940</b><br>(0.799-1.14)  | <b>1.23</b><br>(1.04-1.49)    | <b>1.47</b><br>(1.23-1.76)    | <b>1.79</b><br>(1.48-2.14)    | <b>2.05</b><br>(1.67-2.44)    | <b>2.33</b><br>(1.86-2.76)    | <b>2.61</b><br>(2.05-3.09)    | <b>3.00</b><br>(2.29-3.56)    | <b>3.32</b><br>(2.47-3.95)   |
| <b>6-hr</b>  | <b>0.881</b><br>(0.761-1.04)               | <b>1.11</b><br>(0.969-1.32)   | <b>1.43</b><br>(1.23-1.68)    | <b>1.68</b><br>(1.44-1.96)    | <b>2.02</b><br>(1.71-2.35)    | <b>2.29</b><br>(1.90-2.65)    | <b>2.57</b><br>(2.10-2.98)    | <b>2.85</b><br>(2.29-3.31)    | <b>3.24</b><br>(2.54-3.77)    | <b>3.55</b><br>(2.72-4.14)   |
| <b>12-hr</b>   | <b>0.981</b><br>(0.858-1.14)               | <b>1.24</b><br>(1.08-1.44)    | <b>1.57</b><br>(1.37-1.82)    | <b>1.83</b><br>(1.58-2.11)    | <b>2.18</b><br>(1.87-2.51)    | <b>2.45</b><br>(2.07-2.81)    | <b>2.73</b><br>(2.27-3.14)    | <b>3.01</b><br>(2.47-3.46)    | <b>3.39</b><br>(2.71-3.91)    | <b>3.68</b><br>(2.89-4.28)   |
| <b>24-hr</b>   | <b>1.16</b><br>(1.04-1.31)                 | <b>1.48</b><br>(1.32-1.67)    | <b>1.91</b><br>(1.70-2.16)    | <b>2.26</b><br>(2.01-2.54)    | <b>2.74</b><br>(2.41-3.08)    | <b>3.11</b><br>(2.73-3.50)    | <b>3.51</b><br>(3.05-3.94)    | <b>3.92</b><br>(3.38-4.40)    | <b>4.48</b><br>(3.82-5.03)    | <b>4.92</b><br>(4.16-5.55)   |
| <b>2-day</b>   | <b>1.26</b><br>(1.12-1.42)                 | <b>1.61</b><br>(1.44-1.81)    | <b>2.11</b><br>(1.88-2.38)    | <b>2.51</b><br>(2.23-2.83)    | <b>3.07</b><br>(2.71-3.45)    | <b>3.51</b><br>(3.08-3.95)    | <b>3.98</b><br>(3.47-4.49)    | <b>4.47</b><br>(3.87-5.04)    | <b>5.16</b><br>(4.41-5.82)    | <b>5.70</b><br>(4.83-6.46)   |
| <b>3-day</b>   | <b>1.33</b><br>(1.19-1.50)                 | <b>1.70</b><br>(1.52-1.92)    | <b>2.24</b><br>(1.99-2.52)    | <b>2.67</b><br>(2.37-3.00)    | <b>3.27</b><br>(2.89-3.68)    | <b>3.76</b><br>(3.30-4.22)    | <b>4.28</b><br>(3.72-4.81)    | <b>4.82</b><br>(4.16-5.43)    | <b>5.59</b><br>(4.76-6.29)    | <b>6.20</b><br>(5.24-7.00)   |
| <b>4-day</b>   | <b>1.40</b><br>(1.25-1.58)                 | <b>1.79</b><br>(1.60-2.02)    | <b>2.36</b><br>(2.10-2.66)    | <b>2.83</b><br>(2.50-3.18)    | <b>3.48</b><br>(3.07-3.91)    | <b>4.01</b><br>(3.51-4.50)    | <b>4.57</b><br>(3.98-5.13)    | <b>5.17</b><br>(4.45-5.81)    | <b>6.02</b><br>(5.12-6.76)    | <b>6.70</b><br>(5.64-7.55)   |
| <b>7-day</b>   | <b>1.56</b><br>(1.39-1.76)                 | <b>1.99</b><br>(1.77-2.25)    | <b>2.63</b><br>(2.33-2.96)    | <b>3.14</b><br>(2.78-3.54)    | <b>3.87</b><br>(3.40-4.35)    | <b>4.45</b><br>(3.90-5.00)    | <b>5.08</b><br>(4.41-5.70)    | <b>5.74</b><br>(4.94-6.45)    | <b>6.67</b><br>(5.67-7.50)    | <b>7.42</b><br>(6.24-8.37)   |
| <b>10-day</b>  | <b>1.69</b><br>(1.51-1.91)                 | <b>2.17</b><br>(1.93-2.44)    | <b>2.86</b><br>(2.54-3.21)    | <b>3.41</b><br>(3.02-3.83)    | <b>4.19</b><br>(3.69-4.69)    | <b>4.81</b><br>(4.21-5.38)    | <b>5.47</b><br>(4.76-6.12)    | <b>6.17</b><br>(5.33-6.91)    | <b>7.14</b><br>(6.09-8.00)    | <b>7.93</b><br>(6.69-8.89)   |
| <b>20-day</b>  | <b>2.08</b><br>(1.86-2.33)                 | <b>2.67</b><br>(2.39-3.00)    | <b>3.53</b><br>(3.15-3.95)    | <b>4.18</b><br>(3.71-4.67)    | <b>5.05</b><br>(4.47-5.64)    | <b>5.72</b><br>(5.04-6.38)    | <b>6.40</b><br>(5.61-7.15)    | <b>7.09</b><br>(6.19-7.93)    | <b>8.02</b><br>(6.94-8.99)    | <b>8.73</b><br>(7.50-9.81)   |
| <b>30-day</b>  | <b>2.43</b><br>(2.16-2.72)                 | <b>3.12</b><br>(2.79-3.50)    | <b>4.12</b><br>(3.66-4.60)    | <b>4.87</b><br>(4.32-5.43)    | <b>5.88</b><br>(5.20-6.55)    | <b>6.65</b><br>(5.86-7.41)    | <b>7.45</b><br>(6.53-8.29)    | <b>8.26</b><br>(7.20-9.19)    | <b>9.34</b><br>(8.09-10.4)    | <b>10.2</b><br>(8.74-11.4)   |
| <b>45-day</b>  | <b>2.81</b><br>(2.52-3.15)                 | <b>3.62</b><br>(3.24-4.05)    | <b>4.77</b><br>(4.27-5.33)    | <b>5.62</b><br>(5.01-6.27)    | <b>6.74</b><br>(5.99-7.52)    | <b>7.58</b><br>(6.72-8.45)    | <b>8.43</b><br>(7.43-9.40)    | <b>9.27</b><br>(8.14-10.4)    | <b>10.4</b><br>(9.05-11.6)    | <b>11.2</b><br>(9.73-12.6)   |
| <b>60-day</b>  | <b>3.11</b><br>(2.79-3.47)                 | <b>4.01</b><br>(3.60-4.47)    | <b>5.28</b><br>(4.73-5.87)    | <b>6.19</b><br>(5.54-6.90)    | <b>7.39</b><br>(6.59-8.22)    | <b>8.27</b><br>(7.35-9.20)    | <b>9.15</b><br>(8.11-10.2)    | <b>10.0</b><br>(8.84-11.2)    | <b>11.1</b><br>(9.78-12.5)    | <b>12.0</b><br>(10.4-13.4)   |

<sup>1</sup> Precipitation frequency (PF) estimates in this table are based on frequency analysis of partial duration series (PDS). Numbers in parenthesis are PF estimates at lower and upper bounds of the 90% confidence interval. The probability that precipitation frequency estimates (for a given duration and average recurrence interval) will be greater than the upper bound (or less than the lower bound) is 5%. Estimates at upper bounds are not checked against probable maximum precipitation (PMP) estimates and may be higher than currently valid PMP values. Please refer to NOAA Atlas 14 document for more information.

[Back to Top](#)

# PF graphical

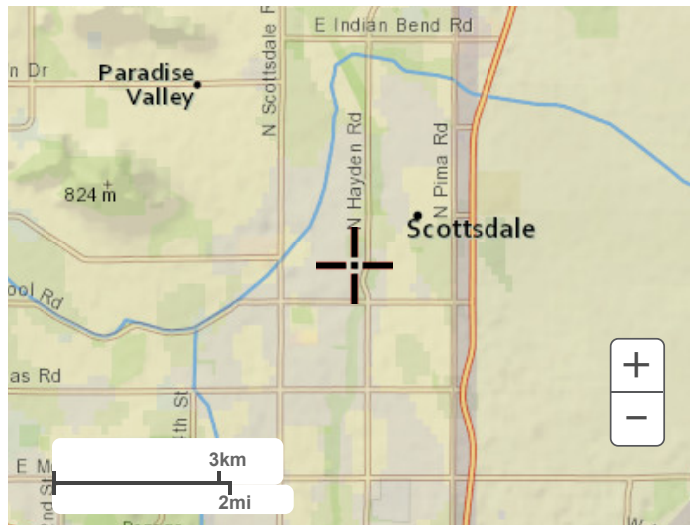
PDS-based depth-duration-frequency (DDF) curves  
 Latitude: 33.5008°, Longitude: -111.9114°



[Back to Top](#)

## Maps & aerials

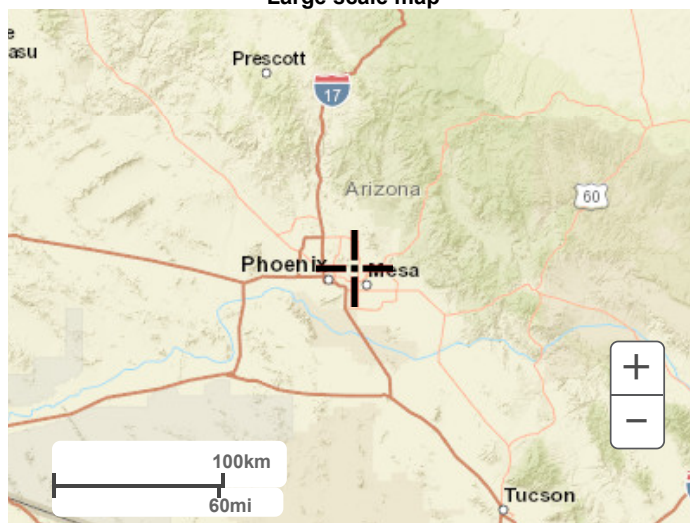
Small scale terrain



Large scale terrain



Large scale map



Large scale aerial

---

## Cross Section for Section A-A

---

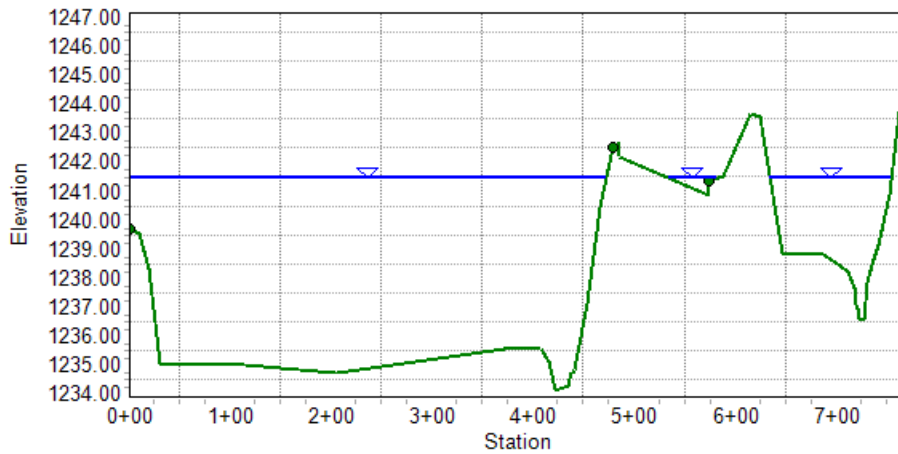
### Project Description

|                 |                 |
|-----------------|-----------------|
| Friction Method | Manning Formula |
| Solve For       | Normal Depth    |

### Input Data

|               |          |                    |
|---------------|----------|--------------------|
| Channel Slope | 0.00420  | ft/ft              |
| Normal Depth  | 7.33     | ft                 |
| Discharge     | 30000.00 | ft <sup>3</sup> /s |

### Cross Section Image





## Worksheet for Section A-A

### Input Data

| Station (ft) | Elevation (ft) |
|--------------|----------------|
| 7+11         | 1238.20        |
| 7+17         | 1237.69        |
| 7+19         | 1237.04        |
| 7+20         | 1236.95        |
| 7+22         | 1236.56        |
| 7+27         | 1236.60        |
| 7+31         | 1237.91        |
| 7+36         | 1238.63        |
| 7+42         | 1239.16        |
| 7+53         | 1240.92        |
| 7+64         | 1244.73        |
| 7+68         | 1245.17        |
| 7+70         | 1245.70        |
| 7+71         | 1246.94        |

### Options

|                                   |                     |
|-----------------------------------|---------------------|
| Current Roughness weighted Method | Pavlovskii's Method |
| Open Channel Weighting Method     | Pavlovskii's Method |
| Closed Channel Weighting Method   | Pavlovskii's Method |

### Results

|                  |                    |                 |
|------------------|--------------------|-----------------|
| Normal Depth     | 7.33               | ft              |
| Elevation Range  | 1234.13 to 1246.94 | ft              |
| Flow Area        | 3161.92            | ft <sup>2</sup> |
| Wetted Perimeter | 644.71             | ft              |
| Hydraulic Radius | 4.90               | ft              |
| Top Width        | 640.15             | ft              |
| Normal Depth     | 7.33               | ft              |
| Critical Depth   | 6.27               | ft              |
| Critical Slope   | 0.00770            | ft/ft           |
| Velocity         | 9.49               | ft/s            |
| Velocity Head    | 1.40               | ft              |



---

## Worksheet for Section A-A

---

### Results

|                 |             |    |
|-----------------|-------------|----|
| Specific Energy | 8.73        | ft |
| Froude Number   | 0.75        |    |
| Flow Type       | Subcritical |    |

### GVF Input Data

|                  |      |    |
|------------------|------|----|
| Downstream Depth | 0.00 | ft |
| Length           | 0.00 | ft |
| Number Of Steps  | 0    |    |

### GVF Output Data

|                     |          |       |
|---------------------|----------|-------|
| Upstream Depth      | 0.00     | ft    |
| Profile Description |          |       |
| Profile Headloss    | 0.00     | ft    |
| Downstream Velocity | Infinity | ft/s  |
| Upstream Velocity   | Infinity | ft/s  |
| Normal Depth        | 7.33     | ft    |
| Critical Depth      | 6.27     | ft    |
| Channel Slope       | 0.00420  | ft/ft |
| Critical Slope      | 0.00770  | ft/ft |

# APPENDIX C

EXCERPTS FROM FLO-2D WEB TOOL

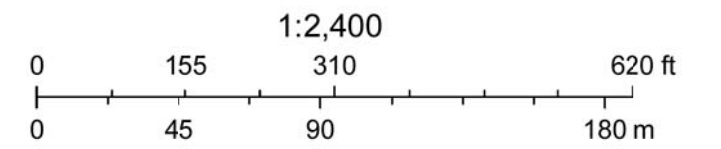
EXCERPTS FROM GENERAL DESIGN MEMORANDUM – PHASE 1, PLAN FORMULATION  
FOR INDIAN BEND WASH



# 679\_LIBW - South 100YR6HR



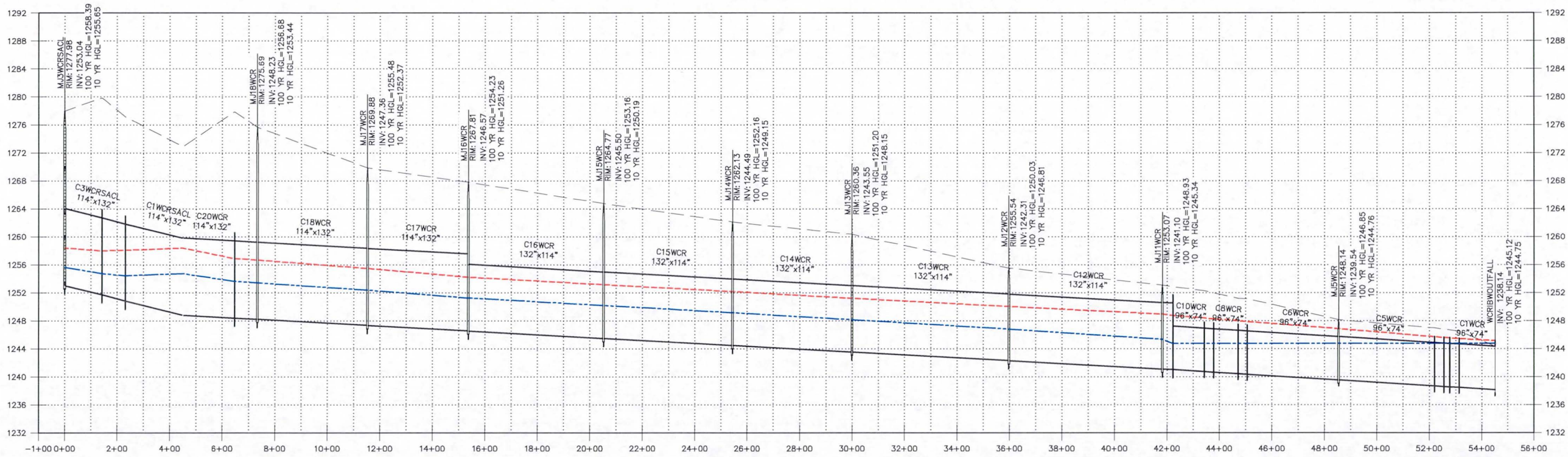
May 16, 2019











SHEET SD6 OF SD121

**Gavan & Barker**  
Civil Engineering & Landscape Architecture  
2030 North Central Avenue, Suite 1500  
Phoenix, AZ 85012 Phone: 602-269-0351

**TYLIN INTERNATIONAL**  
engineers | planners | scientists

### LOWER INDIAN BEND WASH ADMS/P STUDY AREA-SOUTH

SWMM Outfall:  
**WCRIBWOUTFALL**  
(West Camelback Road S.D. Outfall)

|          | By  | Date       |
|----------|-----|------------|
| Prepared | AJA | 12/18/2017 |
| Checked  | MTG | 1/11/2018  |

**Legend (Plan)**

- Inlet & SWMM Identifier
- Manhole & SWMM Identifier
- ▲ Outlet & SWMM Identifier
- Storm Drain Pipes

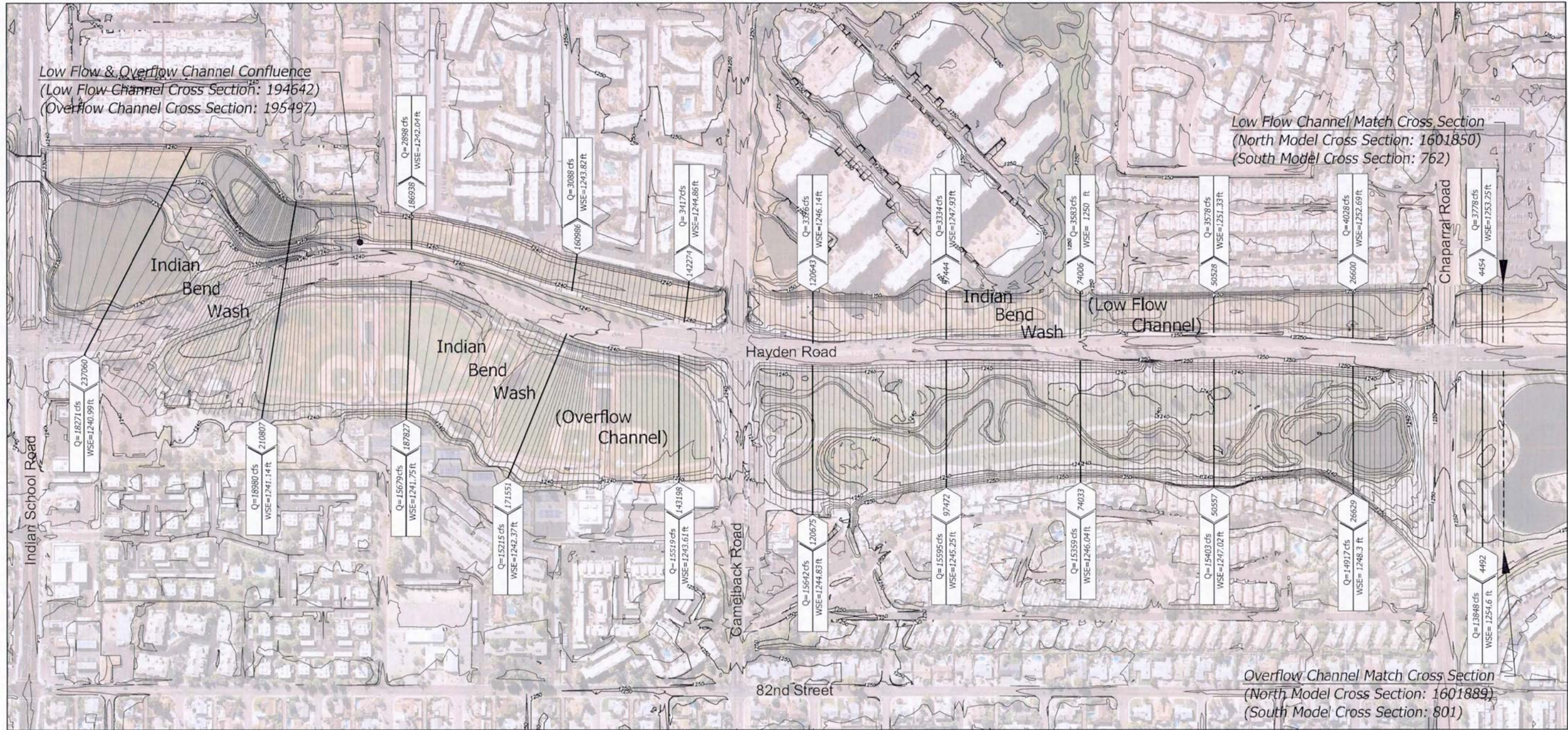
**Legend (Profile)**

- Ground Elevation
- - - Hydraulic Grade Line (100yr, 6-hr)
- - - Hydraulic Grade Line (10yr, 6-hr)

Scale: 1"=400' Horizontal  
1"=15' Vertical

11-ZN-2019  
06/12/19

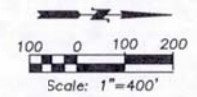




NOTE: The displayed results were obtained from the CHANMAX.OUT file for the governing 100-year storm (6-hour).

### LOWER INDIAN BEND WASH ADMS/P STUDY AREA-SOUTH

- Legend**
- B A Channel Cross Section ID
  - C Peak Discharge (100yr, 6-hr)
  - C Max Water Surface Elevation
  - Reference Channel Cross Section
  - Channel Cross Section



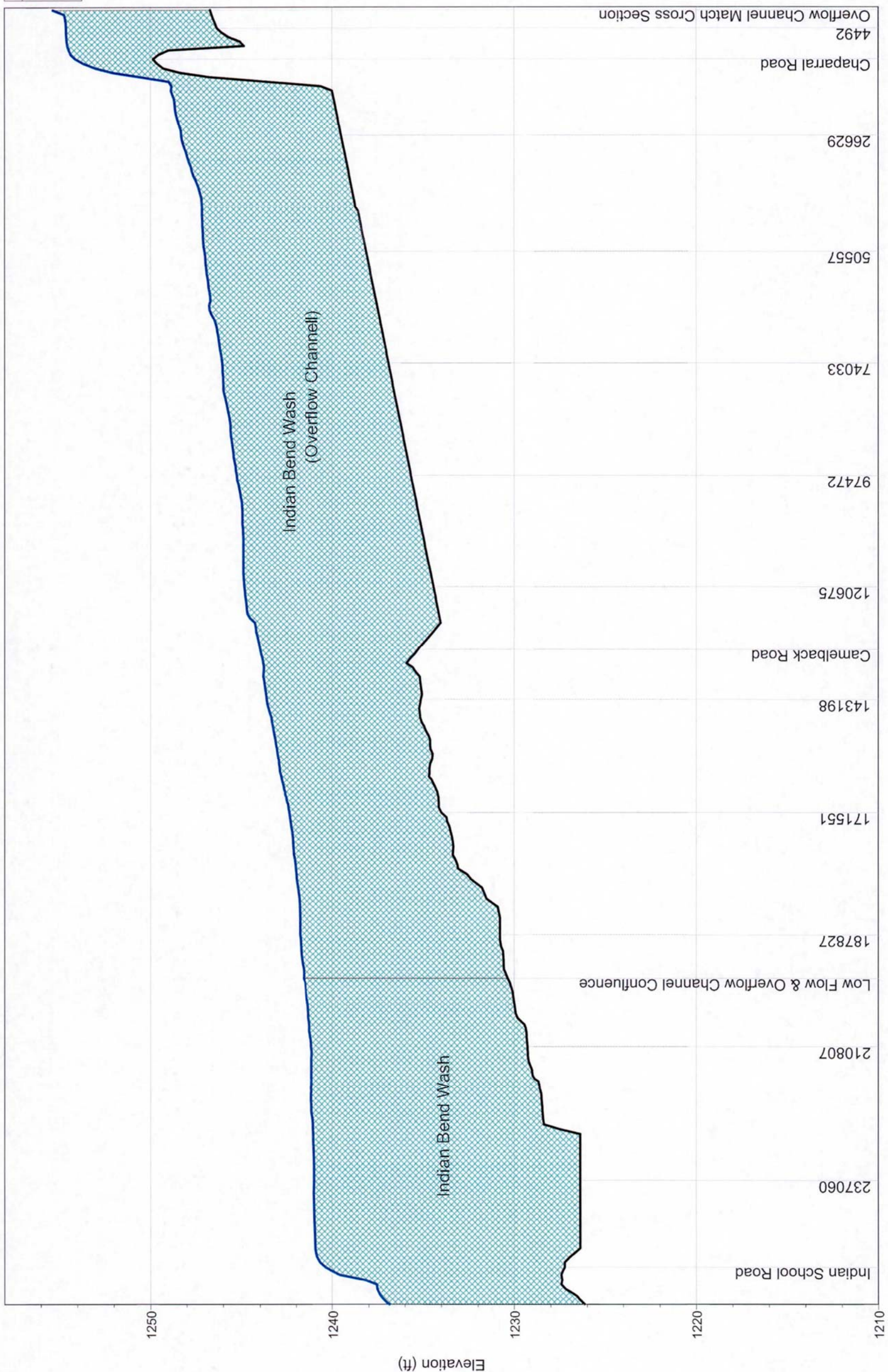
| Cross Section Map<br>Indian Bend Wash<br>(Indian School Road to Chaparral Road) |     |            |
|---|-----|------------|
|   | By  | Date       |
| Prepared  | AJA | 12/28/2017 |
| Checked   | MTG | 12/28/2017 |

**Gavan & Barker**  
Civil Engineering & Landscape Architecture  
1303 North Central Avenue, Suite 1300  
Phoenix, AZ 85012 Phone: 482-500-0331

**TYLIN INTERNATIONAL**  
engineers | planners | scientists



| Legend |             |
|--------|-------------|
|        | FLO-2D WSEL |
|        | Ground      |



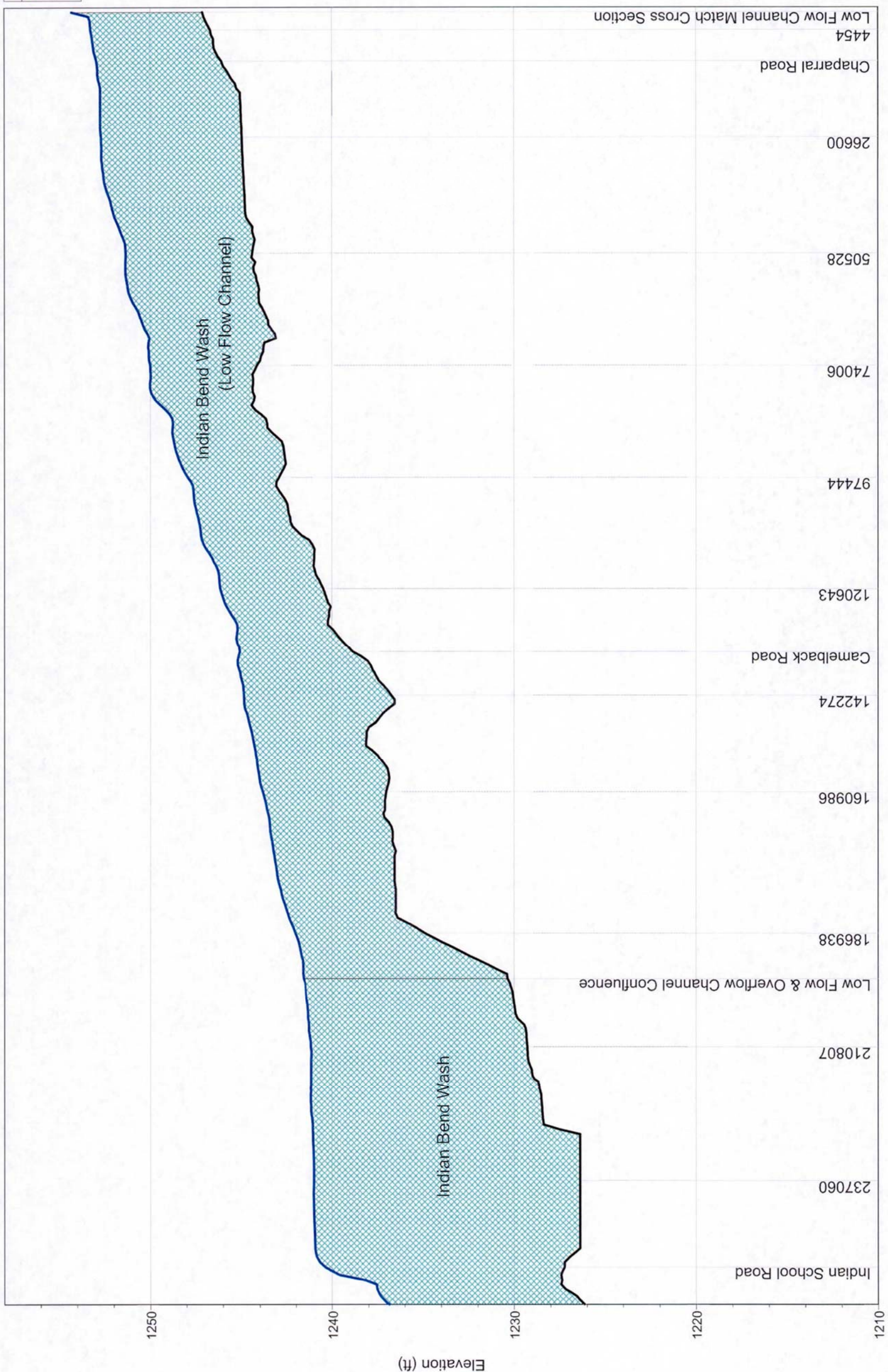
NOTE: The ground profile was taken from the XSEC.DAT file and the max water surface elevation was taken from the CHANMAX.OUT file; both are displayed using HEC-RAS.

| Water Surface Profile                                      |                  |
|--|------------------|
| Indian Bend Wash<br>(Indian School Road to Chapparal Road) |                  |
| Prepared   | By: AJA          |
| Checked  | By: MTG          |
|  | Date: 12/28/2017 |
|  | Date: 12/28/2017 |

**LOWER INDIAN BEND WASH ADMS/P  
STUDY AREA-SOUTH**

Gavan & Barker, Inc.  
TYLINTERNATIONAL  
Flood Control District of Tarrant County





| Legend |             |
|--------|-------------|
|        | FLO-2D WSEL |
|        | Ground      |

NOTE: The ground profile was taken from the XSEC.DAT file and the max water surface elevation was taken from the CHANMAX.OUT file; both are displayed using HEC-RAS.

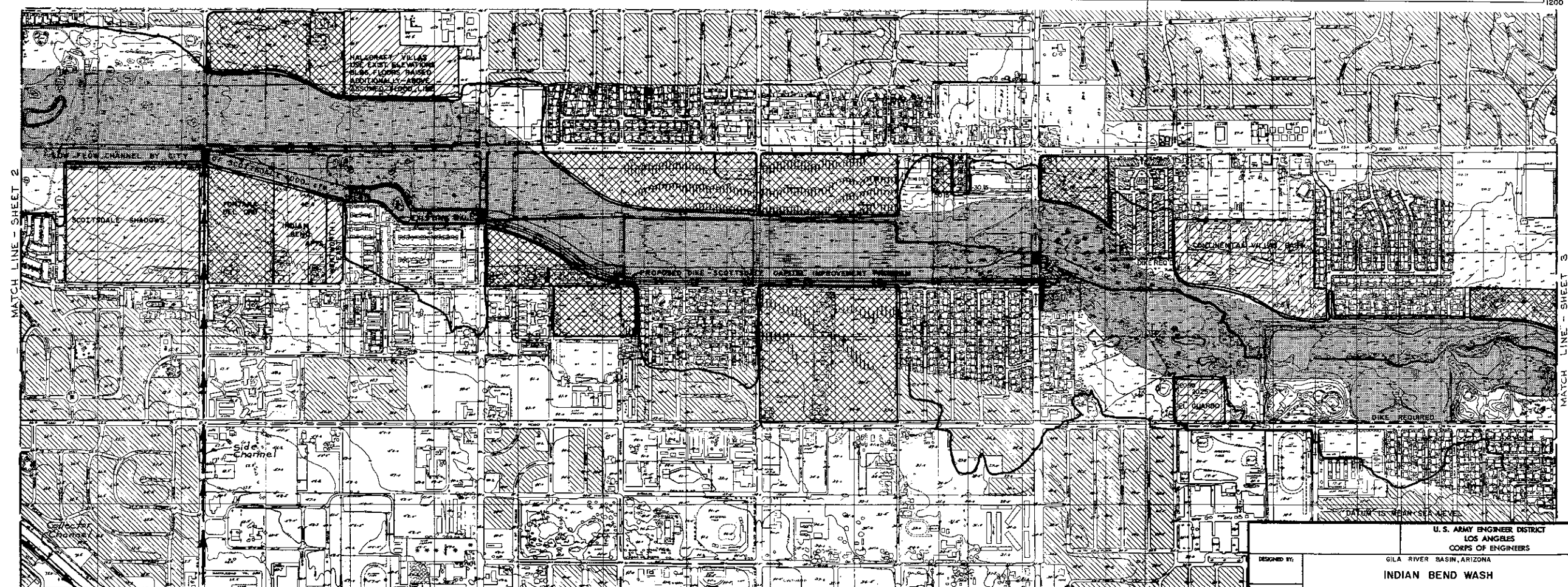
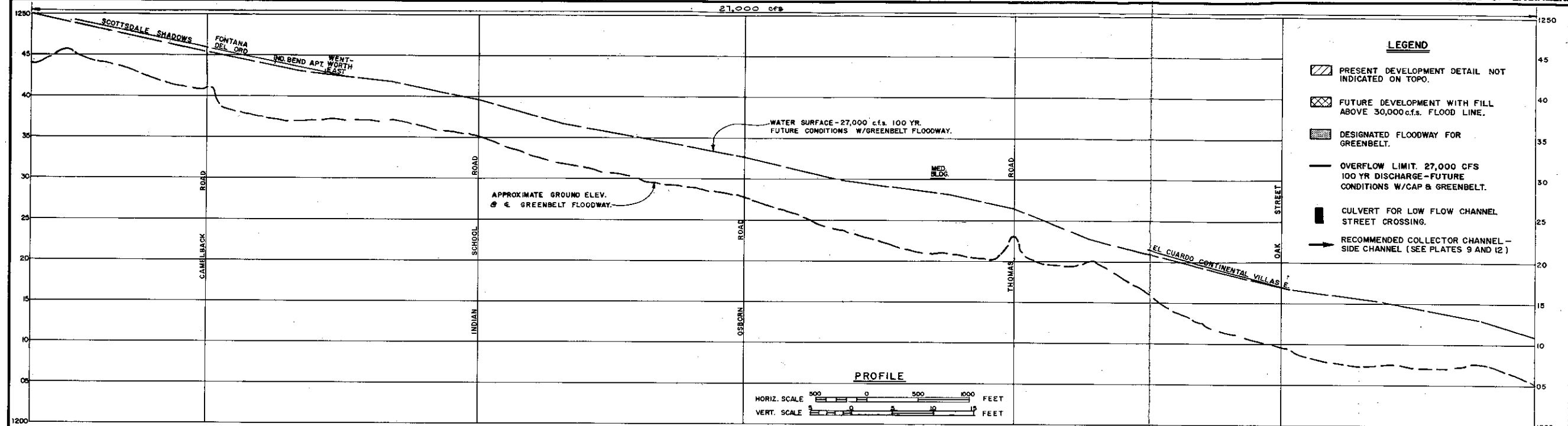
| Water Surface Profile                                      |     |            |  |
|--|-----|------------|--|
| Indian Bend Wash<br>(Indian School Road to Chaparral Road) |     |            |  |
| Prepared   | By  | Date       |  |
| AJA  | AJA | 12/28/2017 |  |
| Checked  | By  | Date       |  |
| MTG  | MTG | 12/28/2017 |  |

**LOWER INDIAN BEND WASH ADMS/P  
STUDY AREA-SOUTH**

**Gavan & Barker**  
CONSULTING ENGINEERS ARCHITECTS  
PLANNERS  
10000 N. 26th Street, Suite 100, Phoenix, AZ 85016  
**TYLIN INTERNATIONAL**  
engineers | planners | scientists







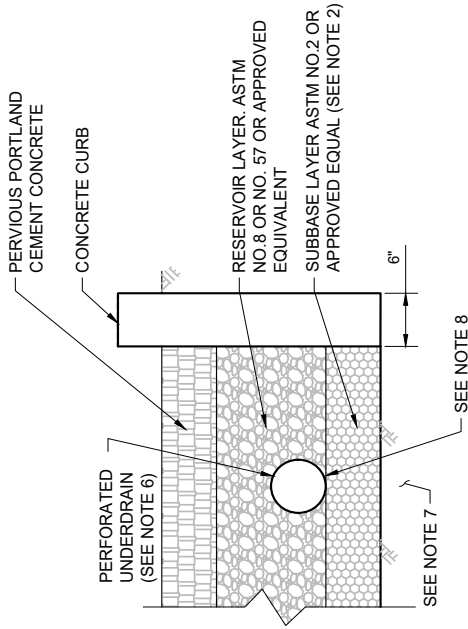
**NOTE:**  
 Overflow area reflects future development with fill above 30,000 cfs flood line.  
 Areas indicated as flooded will be subject to floodproofing measures by the city of Scottsdale as shown.  
 Where dike is shown in front of fill, solution is optional.

|                       |  |  |  |
|-----------------------|--|--|--|
| DESIGNED BY:          |  | U.S. ARMY ENGINEER DISTRICT<br>LOS ANGELES<br>CORPS OF ENGINEERS                   |  |
| DRAWN BY:<br>R.S.H.   |  | GILA RIVER BASIN, ARIZONA  |  |
| CHECKED BY:           |  | INDIAN BEND WASH   |  |
| SUBMITTED BY:         |  | GREENBELT FLOODWAY<br>RECOMMENDED PLAN<br>GREENBELT FLOODWAY WITH INLET AND OUTLET |  |
| APPROVED:             |  | SHEET<br>2<br>OF<br>3  |  |
| APPROVAL RECOMMENDED: |  | SPEC. NO. DACW 09-...<br>DISTRICT FILE NO. 238/47                                  |  |

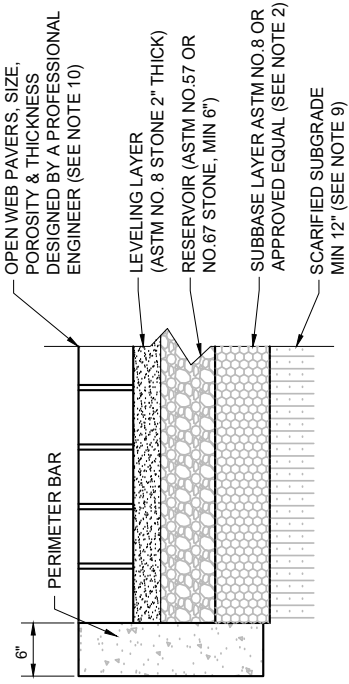
# APPENDIX D

## STORM WATER QUALITY EXAMPLES

# SECTION 2 - LID DETAILS AND SPECIFICATIONS



**PERVIOUS CONCRETE**



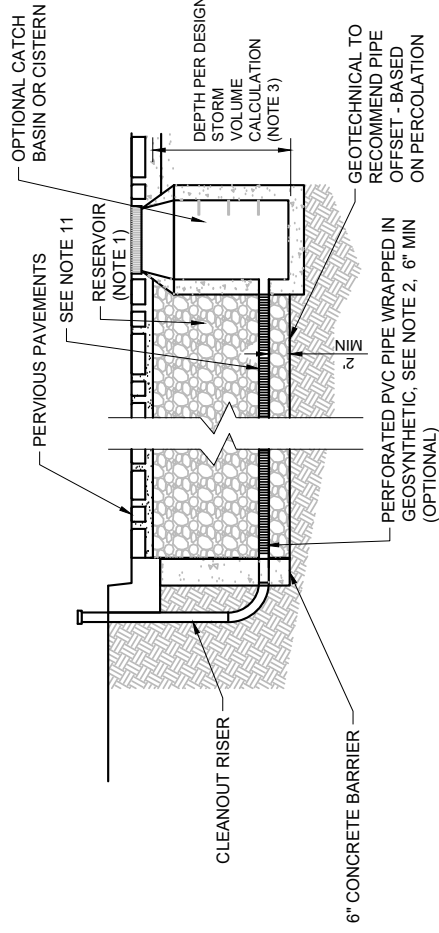
**PERVIOUS CONCRETE PAVERS**

**NOTES:**

1. AGGREGATE LAYERS SHALL MEET PROPOSED SPECIAL PROVISION 303.
2. GEOSYNTHETIC TO BE USED TO PROTECT PIPES FROM CLOGGING. SEE MAG SPECIFICATION 796.
3. DEPTH OF RESERVOIR LAYER AS SHOWN ON DESIGN PLANS SHOULD BE SIZED TO DRAIN WITHIN 72 HOURS.
4. TOP OF PAVEMENT SHOULD BE DESIGNED TO ACHIEVE 1% MAXIMUM SLOPE IN ANY DIRECTION.
5. WHEN FILTER LAYER IS OMITTED, PROVIDE GEOSYNTHETIC CLASS-A MATERIAL BENEATH RESERVOIR LAYER.
6. UNDERDRAIN REQUIRED FOR LOW PERCOLATING SOILS (SEE SPECIFICATION 622).
7. UNCOMPACTED SUBGRADE FOR AREAS DESIGNED FOR INFILTRATION FEATURES ONLY.
8. GEOSYNTHETIC MATERIAL (SEE SPECIFICATION 796) COMPACTION REQUIREMENTS IF ANY WILL BE DESIGNED BY GEOTECHNICAL ENGINEER.
10. SOLID PAVERS CAN BE USED (OPTIONAL).
11. MINIMUM COVER OVER THE UNDERDRAIN PER MANUFACTURER RECOMMENDATION.

**PERVIOUS CONCRETE PAVEMENT**

| PAVEMENT ITEM                     | MINIMUM PAVEMENT THICKNESS |                 |
|-----------------------------------|----------------------------|-----------------|
|                                   | CLASS A                    | CLASS B         |
| PERVIOUS PORTLAND CEMENT CONCRETE | 6"                         | 8"              |
| RESERVOIR LAYER                   | 6"- SEE NOTE 3             | 12"- SEE NOTE 3 |
| SUBBASE LAYER                     | 4"                         | 4"              |



**PERMEABLE PAVEMENT**  
**WITH UNDERGROUND RESERVOIR**  
**AND UNDERDRAIN (OPTIONAL)**

DETAIL NO.  
**LID-01**

**STANDARD DETAIL**  
**ENGLISH**

**PERMEABLE PAVEMENT**

REVISED  
01-29-2019

DETAIL NO.  
**LID-01**



# DESIGN PROFESSIONALS FACT SHEET

## PICP Stormwater Benefits

- Infiltrates, filters and decreases stormwater runoff rate and reduces Total Maximum Daily Load (TMDL)
- LEED® point eligible for Sustainable Sites, Water Efficiency, Materials & Resources and /or Innovative Design; Contributes to Green Globe points
- Meets U.S.Environmental Protection Agency (EPA) stormwater performance criteria as a structural best management practice (BMP) while providing parking, road and pedestrian surfaces
- Helps meet local, state and provincial stormwater drainage design criteria and provides compliance with the U.S. National Pollutant Discharge Elimination System (NPDES) regulations
- Provides 100% pervious surface by runoff passing through small, aggregate-filled openings between solid high-strength durable concrete pavers
- Reduces or eliminates stormwater detention and retention ponds, storm sewers, drainage appurtenances and related costs
- May be used on sloped sites with proper design
- The modular concrete units allow for project phasing; open-graded base and subbase materials are typically available locally.
- Rain water harvesting: capable of storing water for on-site irrigation or building grey water use
- May be designed with underground stormwater storage systems, over many slower-draining clay soils and in cold climates
- Processes and reduces pollutants from vehicular oil drippings

## Pollutant removal efficiencies

(Compared to impervious pavement runoff)

Zinc: 62-88%

Copper: 50-89%

Total Suspended Solids: 60-90%

Total Phosphorous: 65%



- ← 3 1/8 in. (80 mm) thick pavers with permeable joints
- ← Open-graded bedding course
- ← Open-graded base course (OGB)
- ← Open-graded subbase on non-compacted soil subgrade

**Permeable interlocking concrete pavement (PICP) with open-graded base and subbase for infiltration and storage.**

**PICP is a cost effective LID stormwater management tool**



**PICP and bioswales work together as LID tools to increase infiltration at Morton Arboretum in Lisle, IL.**

## APPLICATION OPPORTUNITIES

- **Urban:** Office plazas, sidewalk replacement, street tree planting areas, parking lots, parks and outdoor seating areas
- **Suburban:** Parking lots, parks, driveways, parking bays on roadways, subdivision roads and sidewalks
- **Redevelopment Sites:** Parking areas, plazas and public spaces, sidewalks and brownfields



# LID DESIGN APPLICATION



**350,000 sf (3.2 ha) of PICP at a Burnaby, BC shopping center infiltrates runoff from roofs.**

## **Permeable Interlocking Concrete Pavement Meets Low Impact Development Goals**

- Conserves on-site space: roads, parking, stormwater infiltration and retention all combined into the same space creating more green space or building opportunities
- Preserves wooded areas that would otherwise be cleared for stormwater detention or retention ponds
- Increases site infiltration that helps maintain pre-development runoff volumes, peak flows and time of concentration
- Promotes tree survival and growth
- Contributes to urban heat island reduction through evaporation and reflective, light colored pavers
- Highly visible, cost effective exemplary demonstration of cornerstone LID technique for public and private development

## **Design Software Available**

New software from ICPI for permeable pavement incorporates research from a range of university research studies.

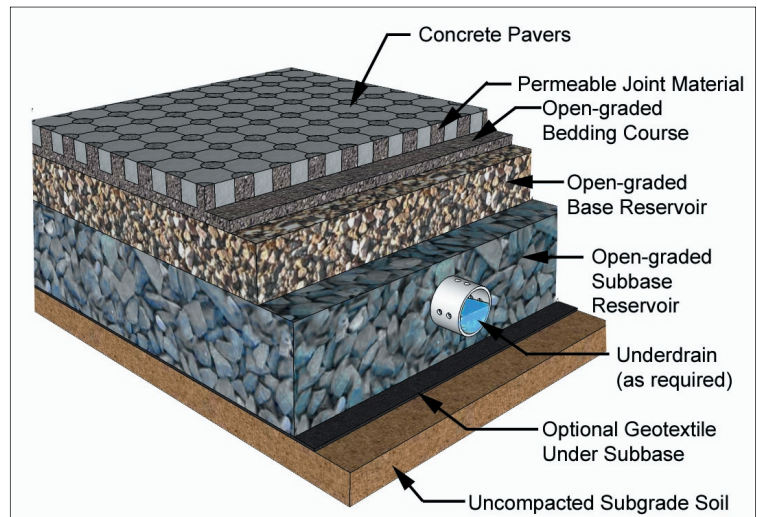
Contact ICPI for further information.

## **Permeable Interlocking Concrete Pavement:**

### **A Low Impact Development Tool**

#### **PICP supports LID Principles**

1. Conserve vital ecological and natural resources: trees, streams, wetlands and drainage courses
2. Minimize hydrologic impacts by reducing imperviousness, conserving natural drainage courses, reducing clearing, grading and pipes
3. Maintain pre-development time of concentration for runoff by routing flows to maintain travel times and discharge control
4. Provide runoff storage and infiltration uniformly throughout the landscape with small, on-site decentralized infiltration, detention and retention practices such as permeable pavement, bioretention, rain gardens, open swales and roof gardens
5. Educate the public and property owners on runoff and pollution prevention measures and benefits



**Typical PICP cross section**



**By eliminating detention pond, the subdivision layout conserves trees while 15,000 sf (1500 m<sup>2</sup>) PICP in the cul-de-sac returns rainfall to the water table in Glen Brook Green subdivision in Waterford, CT.**

11-ZN-2019  
06/12/19



## Technical Guidelines

- Pavers conform to ASTM C936 in the U.S. or CSA A231.2 in Canada
- Open-graded crushed stone recommended for all aggregates
- Joint filling stone gradation: ASTM No. 8, 87, 89 or 9
- Base gradation: ASTM No. 57
- Subbase gradation: ASTM No. 2, 3 or 4 (railroad ballast)
- Optional geotextile: consult manufacturers for selection
- Soil subgrade: classified per ASTM D2487; tested for permeability per ASTM D3385
- Structural design: ICPI design chart determines minimum base thickness to support pedestrian and vehicular traffic (see references)



**Base construction uses locally available materials.**



**Aggregate base and subbase are spread and compacted; pavers are delivered ready to install. After placement, joints and/or openings are filled with small aggregate. Then pavers are compacted.**

## Construction Guidelines



**Pavers are delivered ready to place, joints filled, compacted and then are ready for traffic.**



**Mechanical sweeping of fine aggregate into paver joints**

## Construction Checklist

- No compaction of native soil subgrade – excavate and trim native soil
- Geotextile, drainage pipes and overflow vary with design
- Ensure no sediment from equipment-borne mud on aggregates
- Install and compact aggregate subbase and base with standard paving equipment
- Specialty equipment used for screeding bedding layer and for mechanical paver installation
- Mechanical installation equipment accelerates construction; minimum 5,000 sf (500 m<sup>2</sup>)/ machine/day
- Pavers, non-frozen bedding material & base/subbase installable in freezing temperatures over non-frozen soil subgrade
- Paver joints filled with aggregate and compacted
- No curing time – ready to use upon installation; modular construction allows for project phasing
- Specify experienced ICPI contractors with PICP construction, inspection and detailing skills

## Curve Number and Rational Method Runoff Coefficients

NRCS Curve Numbers (CN) and Rational Method runoff coefficients ('C' value) used depend on the soil infiltration rate, base storage and design storm. In every case, PICP yields significantly lower CN and C values than impervious pavement per the table below:

| Land Cover                                      | Infiltration Rates<br>in./hr (mm/hr)  | Curve Number<br>CN | Runoff Co-efficient,<br>C |
|---|---|--------------------|---------------------------|
| <b>Permeable Interlocking Concrete Pavement</b> | Up to 50 in./ hr (1270 mm/hr) with maintenance<br>3-4 in./hr (75-100 mm/hr) with no maintenance | 45 – 80            | 0.00 – 0.30               |
| <b>Impervious Asphalt or Concrete Pavement</b>  | 0 in./hr (0 mm/hr)  | 95 – 98            | 0.90 – 0.95               |

# PERFORMANCE

## Volume Reduction

Research has demonstrated that PICP can reduce runoff as much as 100% from a 3 in. (75 mm) rain event with sandy soil and a minimum 12 in. (300 mm) thick open-graded aggregate base.

Given regional variations in annual rainstorms and PICP base storage capacities, PICP can reduce annual runoff between 30% and 80%. Well-maintained PICP can reduce flows by 70% to 90% from intense rain events and up to 100% for many storms. *This yields a corresponding reduction in runoff pollution.*

## Peak Flow Reduction and Delay

PICP can reduce peak flow by as much as 89%, producing a hydrograph nearer to pre-development conditions. Peak flow is generally proportional to rainfall intensity. Permeable pavers delay the timing of peak flow runoff from several hours to several days.

## Additional Benefits

- ADA compliant for slip resistance
- Concrete pavers available in various shapes and colors from local ICPI members; colored pavers mark lanes and parking spaces
- Simplifies surface and subsurface repairs by reinstating the same paving units; no unsightly patches or weakened pavement cuts

## Water Quality Improvement

PICP treats stormwater by slowing runoff velocities to allow for sedimentation and filtering by aggregates in the surface openings and base. Oils adhere to small soil particles and aggregates and then are digested by bacteria.

## FAQS

**Can PICP be used on clay soils?** *Yes. Even in clay soils, PICP reduces runoff and helps to capture "first flush" runoff and reduce pollution.*

**Can PICP be used to replace conventional stormwater management tools such as detention basins?** *Yes. In both colder and warmer climates, PICP has been used to reduce or eliminate the need for conventional stormwater pipe infrastructure, detention basins and drop inlets.*

**Is Maintaining PICP difficult?** *No. PICP can be maintained through street sweeping and vacuuming based on a periodic inspection.*

**Can PICP be used in cold climates?** *Yes, PICP has been very successful in many Canadian and northern United States applications. It remains stable through freezing and thawing cycles.*

## REFERENCES

Ferguson, B. K. *Porous Pavements*. Boca Raton, FL: CRC Press, 2005.

Smith, David R. *Permeable Interlocking Concrete Pavements: Selection • Design • Construction • Maintenance*, Washington, DC: ICPI 3rd ed., 2006. [www.icpi.org](http://www.icpi.org).

For more information pertaining to permeable interlocking concrete pavement, please visit the Interlocking Concrete Pavement Institute ([icpi.org](http://icpi.org)) or the Low Impact Development Center ([lowimpactdevelopment.org](http://lowimpactdevelopment.org)).

**Other Fact Sheets available for Developers, Municipal Officials and Schools/Universities**



*Disclaimer: The content of this brochure is intended for use only as a guideline. It is not intended for use or reliance upon as an industry standard, certification or specification. ICPI & LIDC make no promises, representations or warranties of any kind, express or implied, as to the content of this brochure. Professional assistance should be sought with respect to the design, specifications and construction of each permeable interlocking concrete pavement project.*

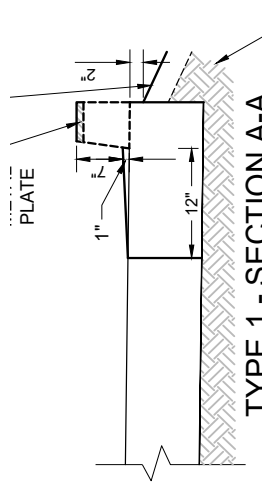


13291 Park Center Road  
Suite 270  
Herndon, VA 20171  
Tel: 703-657-6900  
Fax: 703-657-6901  
Email: [icpi@icpi.org](mailto:icpi@icpi.org)  
Web: [www.icpi.org](http://www.icpi.org)

561 Brant Street  
P.O. Box 85040  
Burlington, Ontario, Canada  
L7R 4K2

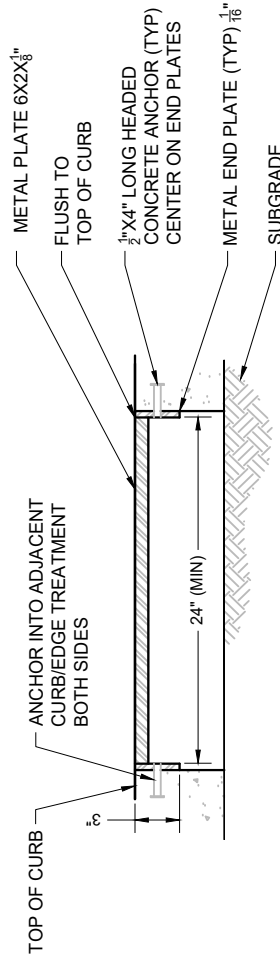
# 10 LID TECHNICAL STANDARD DETAILS AND SPECIFICATIONS

- REQUIREMENTS OF ASTM A-106.
- METAL PLATE 6X2X1/8 CHANNEL SHALL MEET THE REQUIREMENTS OF ASTM A-500 GRADE B.
- END PLATES SHALL MEET THE REQUIREMENTS OF ASTM A-36.
- ENTIRE ASSEMBLY SHALL BE HOT DIP GALVANIZED IN ACCORDANCE WITH ASTM A-123.
- DESIGN VERTICAL WHEEL LOAD IS 8.5 KIPS.
- SEE SPECIFICATION 341 FOR MATERIAL AND CONSTRUCTION INFORMATION.
- REFER TO AASHTO ROADWAY DESIGN GUIDE FOR CLEAR ZONE REQUIREMENTS FOR SPEED DESIGNS.
- DRILL & EPOXY #4X6 REBAR

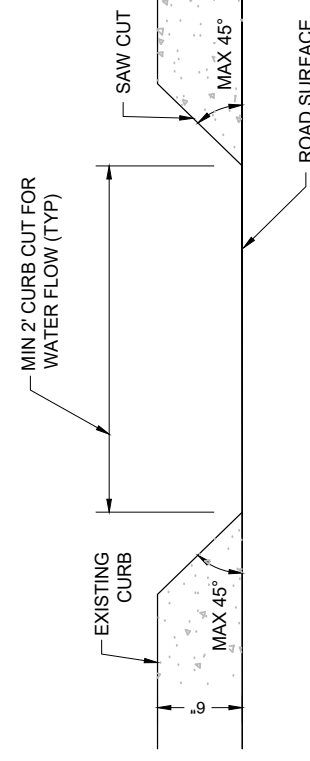


TYPE 1 - SECTION A-A

SUBGRADE



TYPE 1 - SECTION B-B



CURB OPENING - TYPE 2

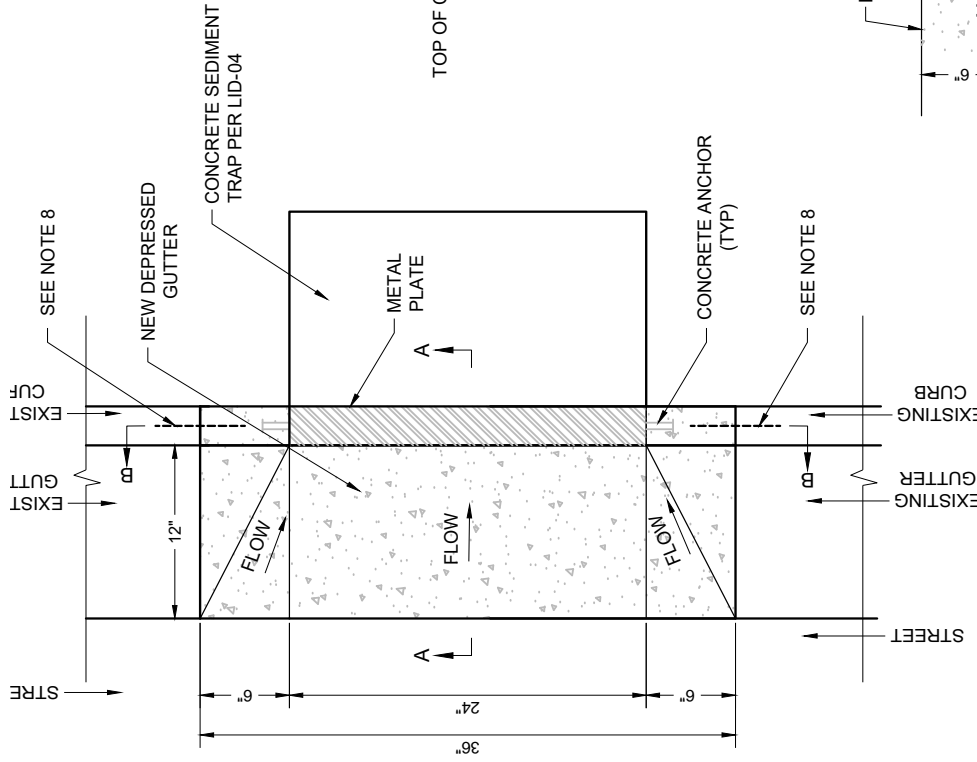
ANGLED CURB CUT

CURB OPENING - TYPE 1

RETROFIT OPENING WITH VERTICAL CUT

### NOTES:

- DO NOT CUT DEEPER THAN ROAD SURFACE ELEVATION.
- ALL CURB OPENINGS SHALL BE MADE BY SAW CUT METHOD.
- GRIND EXPOSED METAL AND SEAL TO PROTECT FROM CORROSION.

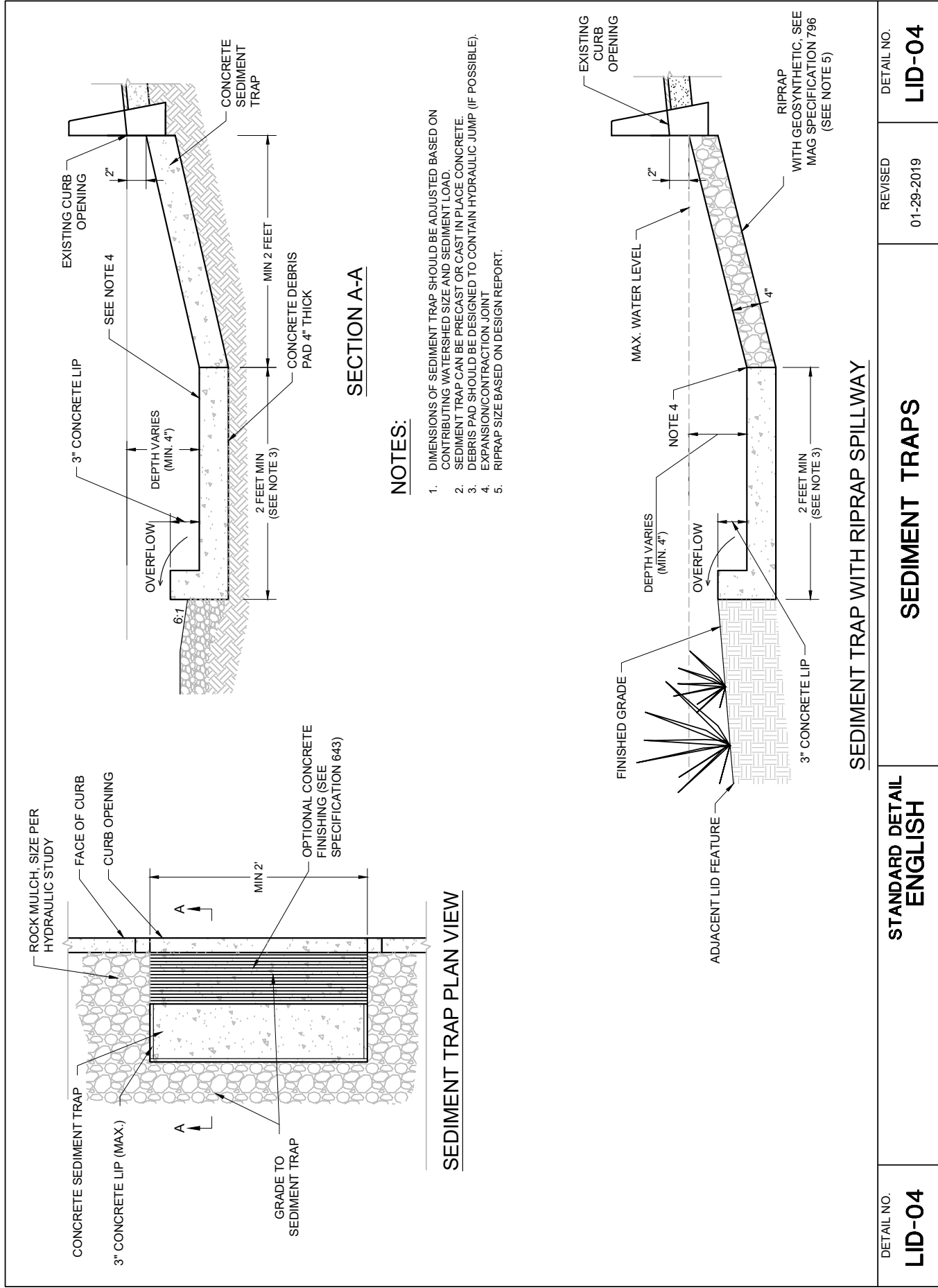


CURB OPENING - TYPE 1

RETROFIT OPENING WITH VERTICAL CUT

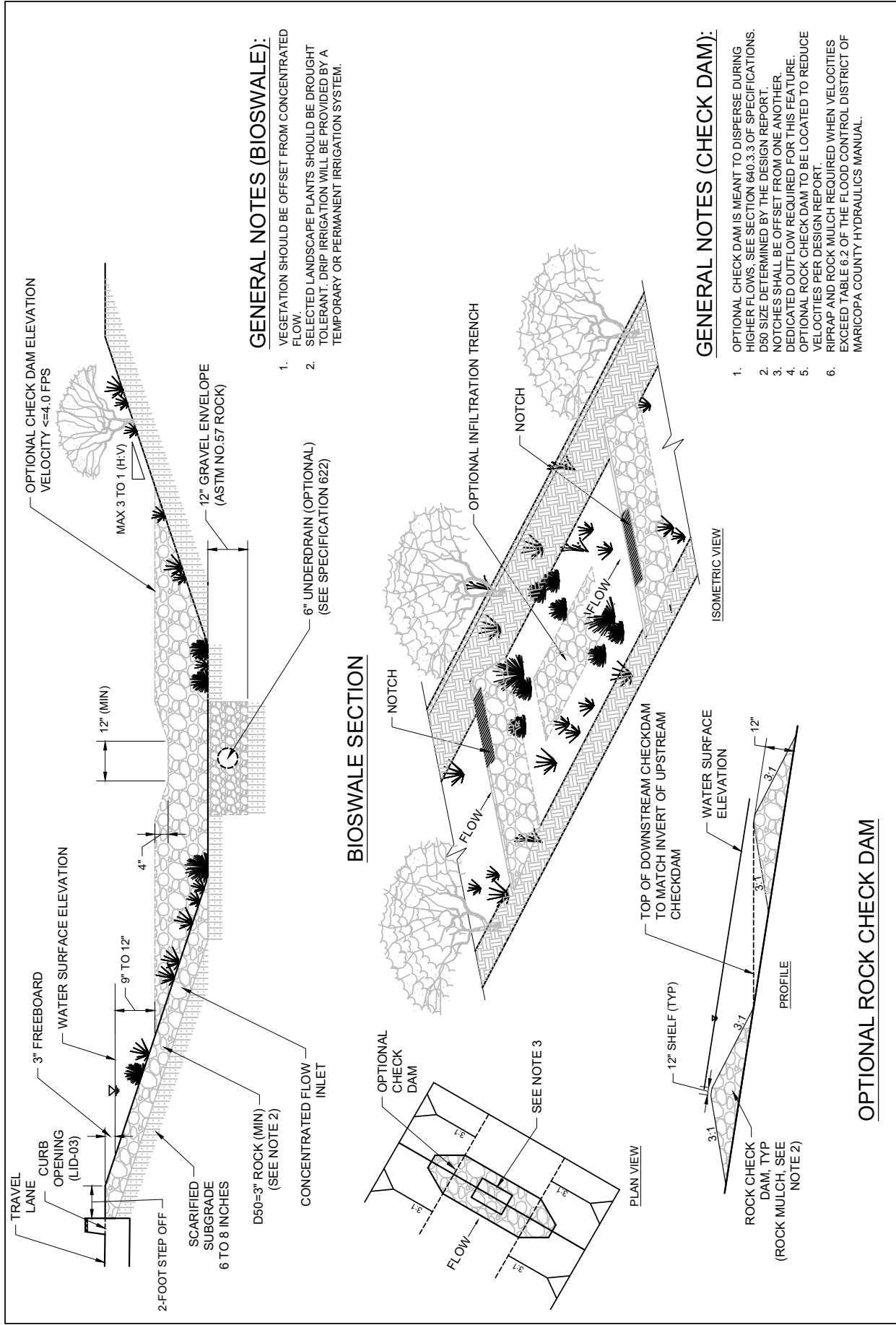
|                             |                                   |                       |                             |
|-----------------------------|-----------------------------------|-----------------------|-----------------------------|
| DETAIL NO.<br><b>.ID-02</b> | STANDARD DETAIL<br><b>ENGLISH</b> | REVISED<br>01-29-2019 | DETAIL NO.<br><b>LID-02</b> |
|-----------------------------|-----------------------------------|-----------------------|-----------------------------|





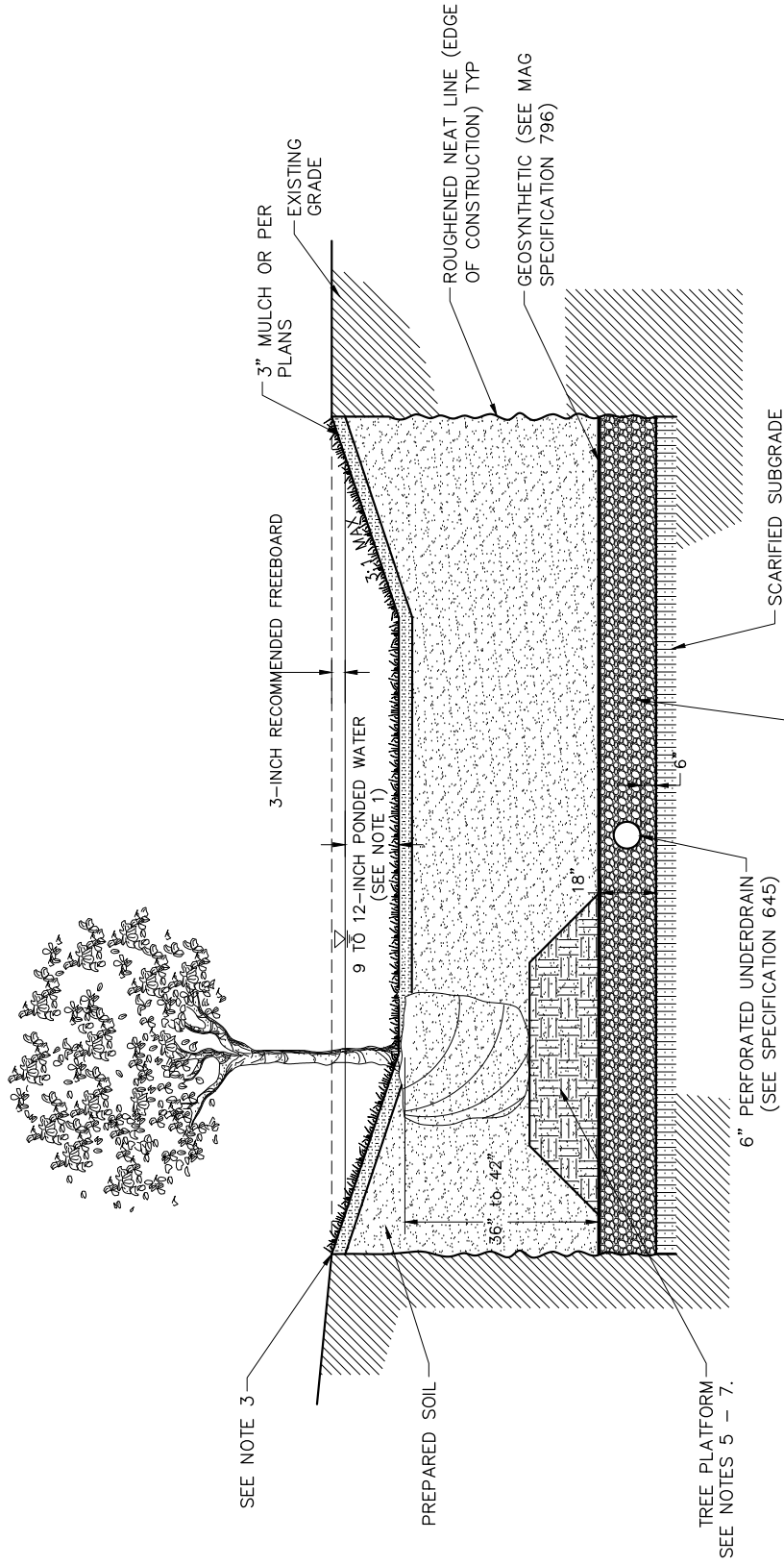
|                             |                                   |   |                             |
|-----------------------------|-----------------------------------|---|-----------------------------|
| DETAIL NO.<br><b>LID-04</b> | STANDARD DETAIL<br><b>ENGLISH</b> | REVISED<br>01-29-2019                     | DETAIL NO.<br><b>LID-04</b> |
| <b>SEDIMENT TRAPS</b>       |                                   | <b>SEDIMENT TRAP WITH RIPRAP SPILLWAY</b> |                             |

# 10 LID TECHNICAL STANDARD DETAILS AND SPECIFICATIONS



|                                    |                                   |                       |                             |
|------------------------------------|-----------------------------------|-----------------------|-----------------------------|
| DETAIL NO.<br><b>LID-06</b>        | STANDARD DETAIL<br><b>ENGLISH</b> | REVISED<br>01-29-2019 | DETAIL NO.<br><b>LID-06</b> |
| <b>VEGETATED OR ROCK BIOSWALES</b> |                                   |                       |                             |

# 10 LID TECHNICAL STANDARD DETAILS AND SPECIFICATIONS



## NOTES:

1. SURFACE PONDED WATER MUST PERCOLATE WITHIN 36-HOURS.
2. MINIMUM DEPTH OF 36 TO 42 INCHES TO ACCOMMODATE 48-INCH BOX TREE PLANTING.
3. SEE SPECIFICATION 645 FOR BUILDING SETBACK DISTANCES.
4. INTENDED TO CAPTURE SUBWATERSHED, DEDICATED OUTLET STILL REQUIRED.
5. TREE PLATFORM SHALL CONSIST OF COMPACTED ON-SITE SOIL. PLATFORM SHALL BE 1.5X THE WIDTH OF THE ROOTBALL AND INCLUDE 45-DEGREE SIDE SLOPES (MAX.).
6. INSTALL FILTER FABRIC BETWEEN TREE PLATFORM AND NO.57 STONE/ROCK MULCH.
7. TREE PLATFORMS TO BE PLACED TREE LOCATIONS. REFER TO LANDSCAPE PLAN.

DETAIL NO.  
**LID-07**

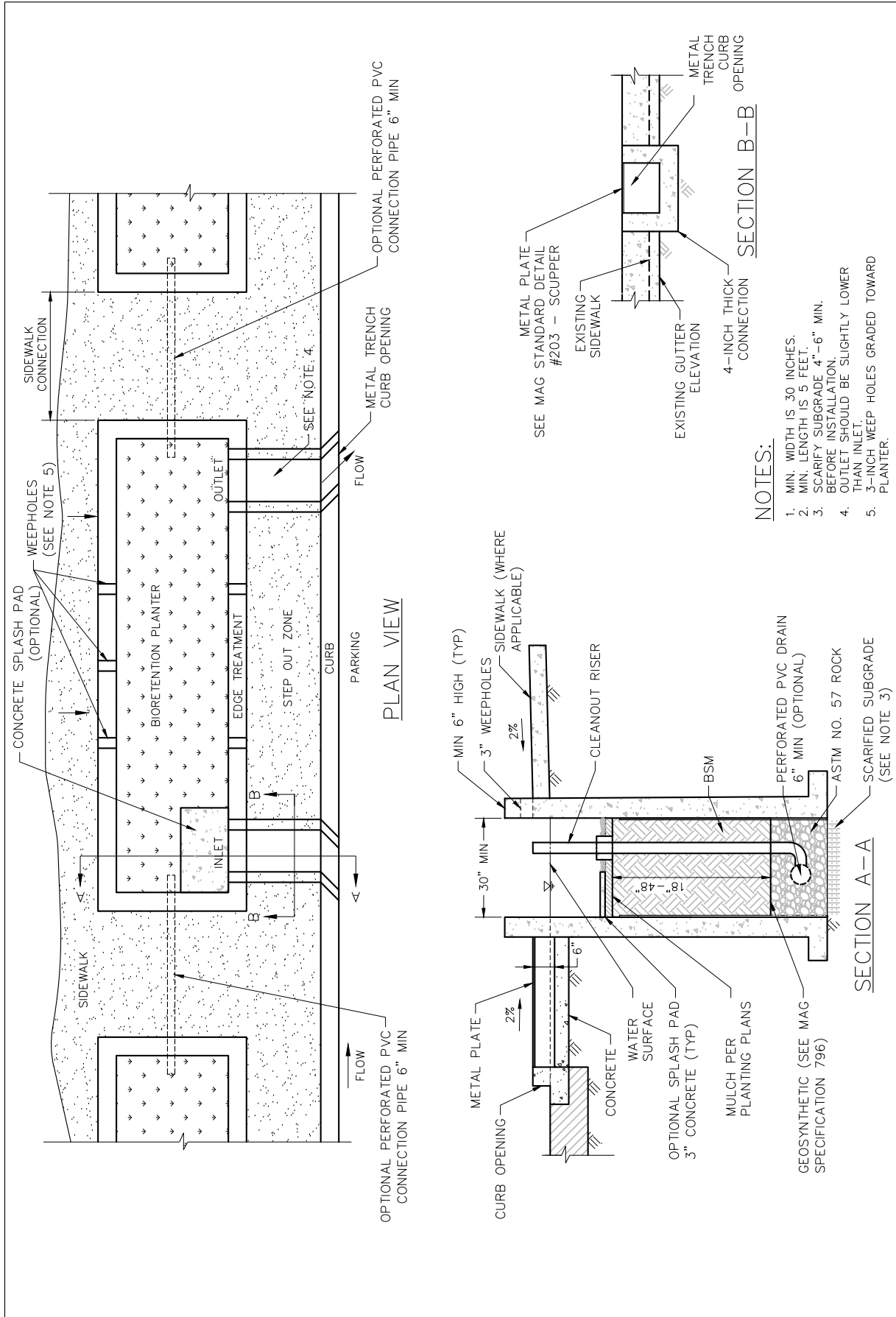
**STANDARD DETAIL**  
**ENGLISH**

**BIORETENTION SYSTEMS**

REVISED  
01-29-2019

DETAIL NO.  
**LID-07**

# 10 LID TECHNICAL STANDARD DETAILS AND SPECIFICATIONS



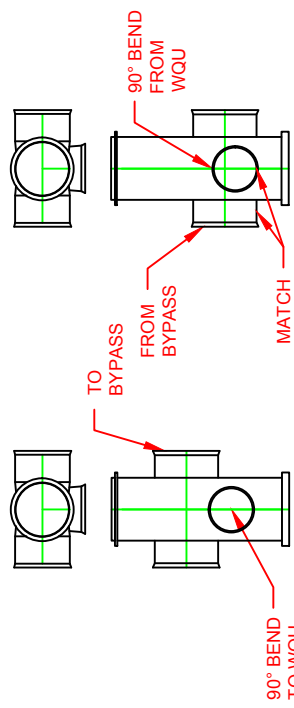
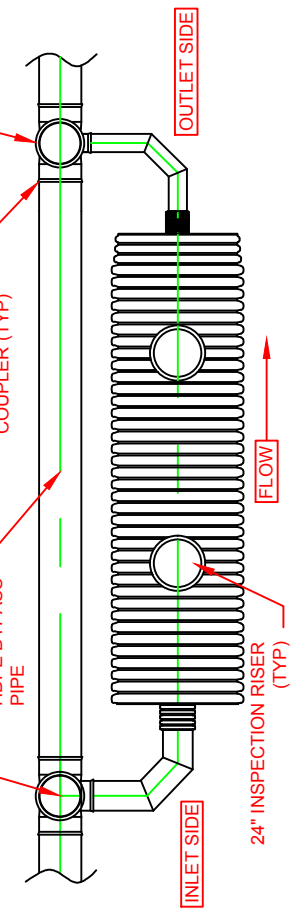
|                             |                                   |                       |                       |                             |
|-----------------------------|-----------------------------------|-----------------------|-----------------------|-----------------------------|
| DETAIL NO.<br><b>LID-09</b> | STANDARD DETAIL<br><b>ENGLISH</b> | BIORETENTION PLANTERS | REVISED<br>01-29-2019 | DETAIL NO.<br><b>LID-09</b> |
|-----------------------------|-----------------------------------|-----------------------|-----------------------|-----------------------------|

**STRUCTURE OPTIONS**

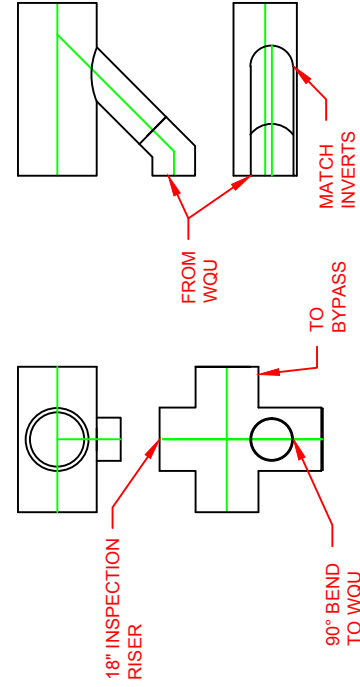
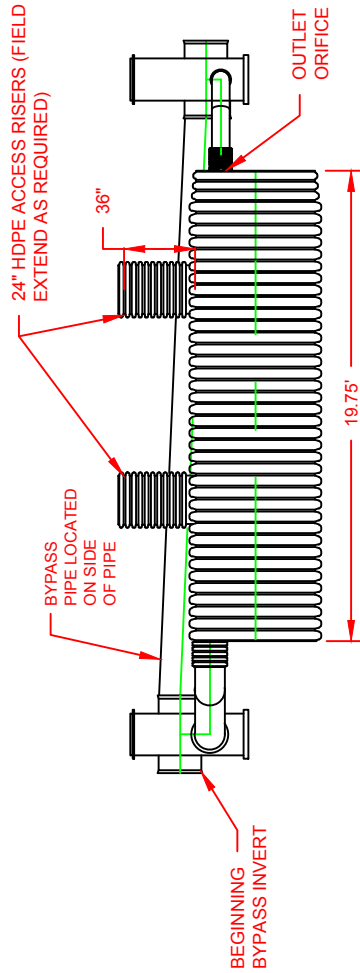
- FITTING DIMENSIONS VARY WITH UNIT DESIGN. DIMENSIONS CAN BE PROVIDED ONCE DESIGN IS EVALUATED.
- COMBINATIONS OF NYLOPLAST BASINS AND FABRICATED FITTINGS ARE AVAILABLE
- STRUCTURES BY OTHERS MAY BE USED.

SHOWN AS NYLOPLAST BASIN. SEE STRUCTURE OPTIONS FOR ALTERNATE CONFIGURATIONS.

SHOWN AS NYLOPLAST BASIN. SEE STRUCTURE OPTIONS FOR ALTERNATE CONFIGURATIONS.



**PLAN VIEW**



**NOTES:**

1. SEE STANDARD DETAILS STD-501 AND STD-502 FOR STORM WATER QUALITY UNIT PRODUCT DETAILS.
2. REFERENCE TECHNICAL NOTE 1.03 FOR ADDITIONAL DESIGN INFORMATION.
3. ELEVATION CHANGE DENOTES THE ELEVATION DROP FROM INVERT OF BYPASS AT INLET TO INVERT OF BYPASS AT OUTLET.

| MODEL #   | MAIN PIPE DIA. | SCREEN SIZE | PARTICLE SIZE (CM) | TREATED FLOW RATE (CFS) | INLET Ø | OUTLET Ø | OUTLET ORIFICE Ø | ELEVATION CHANGE* |
|-----------|----------------|-------------|--------------------|-------------------------|---------|----------|------------------|-------------------|
| 6020WQAXX | 60"            | 140         | 0.0106             | 2.95                    | 15"     | 15"      | 10.05"           | 17.5"             |
| 6020WQBXX | 60"            | 200         | 0.0075             | 1.47                    | 15"     | 15"      | 7.10"            | 17.5"             |

XX DENOTES A BY-PASS SIZE OF 18", 24", 30", 36", 42", 48", OR 60"  
 XX=00 DENOTES UNITS WITHOUT A BY-PASS.  
 \* ELEVATION CHANGE FOR UNITS WITHOUT A BY-PASS IS 2"

© 2016 ADS, INC.

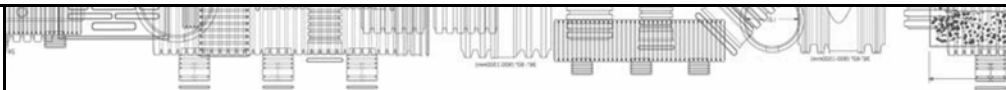
ADVANCED DRAINAGE SYSTEMS, INC. ("ADS") HAS PREPARED THIS DETAIL BASED ON INFORMATION PROVIDED TO ADS. THIS DRAWING IS INTENDED TO DEPICT THE COMPONENTS AS REQUESTED. ADS HAS NOT PERFORMED ANY ENGINEERING OR DESIGN SERVICES FOR THIS PROJECT, NOR HAS ADS INDEPENDENTLY VERIFIED THE INFORMATION SUPPLIED. THE INSTALLATION DETAILS PROVIDED HEREIN ARE GENERAL RECOMMENDATIONS AND ARE NOT SPECIFIC FOR THIS PROJECT. THE DESIGN ENGINEER SHALL REVIEW THESE DETAILS PRIOR TO CONSTRUCTION. IT IS THE DESIGN ENGINEER'S RESPONSIBILITY TO ENSURE THE DETAILS PROVIDED HEREIN MEETS OR EXCEEDS THE APPLICABLE NATIONAL, STATE, OR LOCAL REQUIREMENTS AND TO ENSURE THAT THE DETAILS PROVIDED HEREIN ARE ACCEPTABLE FOR THIS PROJECT.

|      |                                |      |          |      |
|------|--------------------------------|------|----------|------|
| 1    | FORMATTING UPDATES AND RENAMED | T:JR | 02/17/16 | CHKD |
| REV. | DESCRIPTION                    | BY   | MM/DD/YY |      |

60in. 20ft WQU

DRAWING NUMBER: STD-509

CKS  
7/17/08  
4640 TRUMAN BLVD  
HILLIARD, OHIO 43026  
ADVANCED DRAINAGE SYSTEMS, INC.



# TECHNICAL NOTE

Testing of Storm Water Quality Units

TN 1.04  
July 2007

## Introduction

For the last 20 years storm water management has become an increasingly important issue in the United States. This has affected not only the larger metropolitan communities but has begun to become important in smaller rural communities around the country. The areas of interest for these projects are not only storm water quantity but also storm water quality. The ADS Storm Water Quality Unit (SWQU) provides the first step in the treatment train: removal of floating debris, suspended solids, and contaminants.

## Development

The ADS SWQU was developed to provide a simple, effective method for the control of storm water quality. The basic design of the unit is an oil grit separator. The unit consists of an upright weir for trapping sediment and an additional inverted weir for trapping the floatable particles such as oils, grease, and debris. This technology has been around for several years and is very effective until higher event storms. During intense storm events, oil grit separators are subject to resuspension of solids and washout of floating particles. Although the efficiency of the early units was fairly high, they had difficulty retaining the particles that were trapped during high volume storm events.

The ADS SWQU utilizes the same technology but improves upon it to provide a more efficient yet still simple method of controlling water quality. The addition of an external bypass allows higher storm volumes to be bypassed *around* the unit without passing through the unit and causing turbulent flow. This allows the lower volume storms — where most contaminants are flushed off of the pavement — to be trapped by the unit and remain there until the unit is cleaned out. In addition, the ADS SWQU is constructed of High Density Polyethylene (HDPE) which is inert and much more chemical resistant than the standard concrete Oil Grit Separators previously used for these applications.

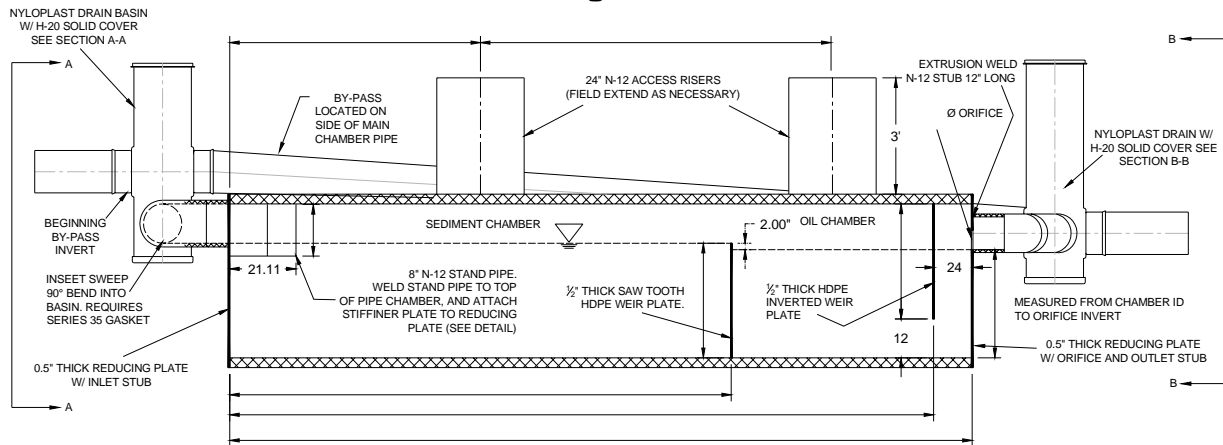
## Design

A full discussion of the SWQU design methodology is available in Technical Note 1.01: *Water Quality Units - EPA Phase II, Best Management Practices*. In summary, the SWQU utilizes Stoke's law in order to predict removal efficiencies based on particle size. The units are designed with a sediment chamber, a floatable chamber, and an outlet chamber to provide the stormwater treatment ability of the unit. All flows above the velocity required are routed through the bypass line to prevent the resuspension and removal of trapped materials from the unit. See Figure 1 for a layout of a typical SWQU.





**Figure 1**



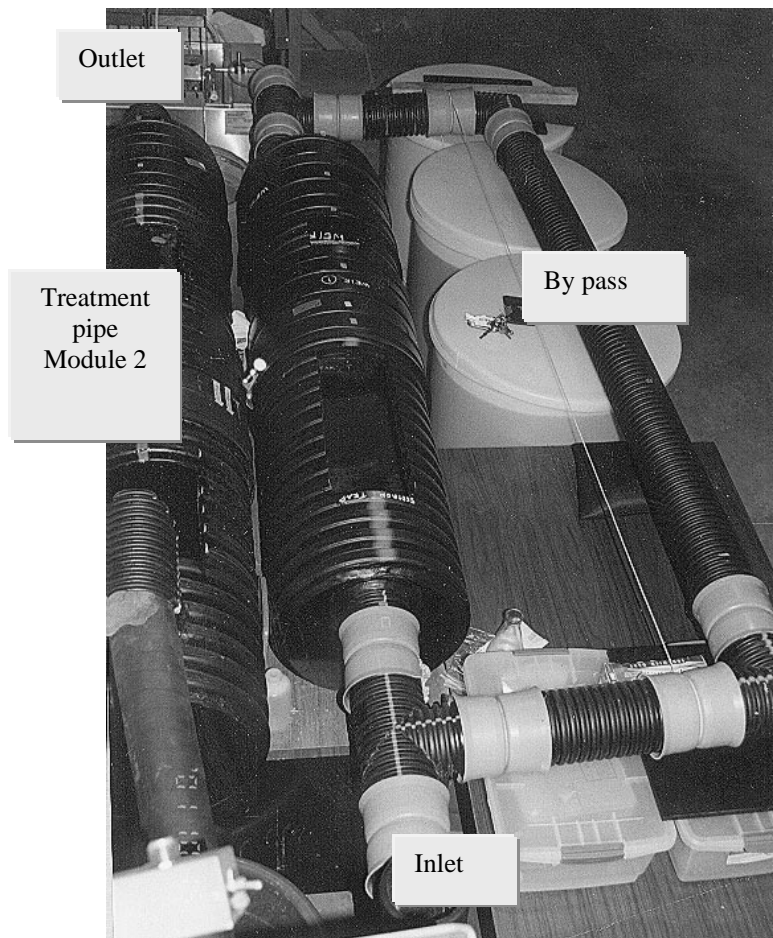
## Laboratory Testing and Research

As with any device designed to treat water quality, testing should be performed to determine the removal rates and efficiencies of the device. The ADS SWQU has been subjected to several different testing protocols to determine the removal rates for both total suspended solids (TSS) and oil and hydrocarbons. Testing has been conducted in both the laboratory and the field. The following summarizes the testing which has been initiated or completed on the ADS SWQU:

### Ohio University Scale Model Lab Testing

Testing consists of a scale model test loop including the Water Quality Unit and the bypass line. The model tested was a 12" diameter Water Quality Unit with appropriate scaled appurtenances. This testing was completed in September of 2003. The model was tested for both sediment and oil removal during the evaluation. A layout of the test loop is shown below in Figure 2.

**Figure 2**

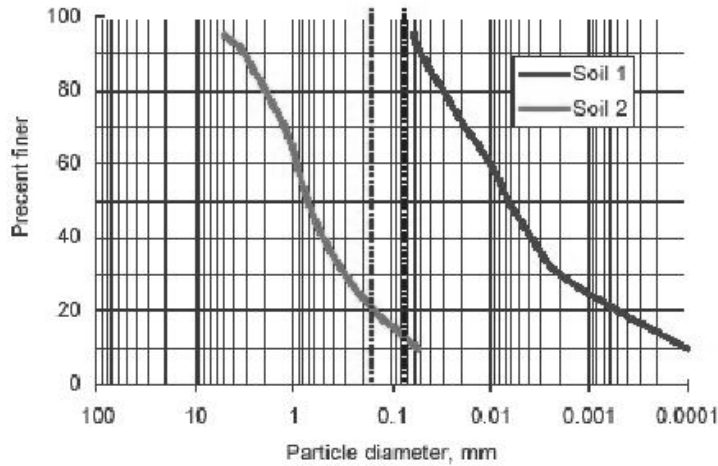


Two different soils were used for the evaluation in the Ohio University Lab study. The soils are shown as Type 1 and Type 2. The Type 1 soil contains particles which are generally smaller than the 200 sieve or 75 micron size. The Type 2 soil contains particles which are generally larger than the 200 sieve or 75 micron size. Sieve analyses for both soil types are shown below in Figure 3 and 4. The vertical lines represent the 140 sieve and 200 sieve particle sizes.



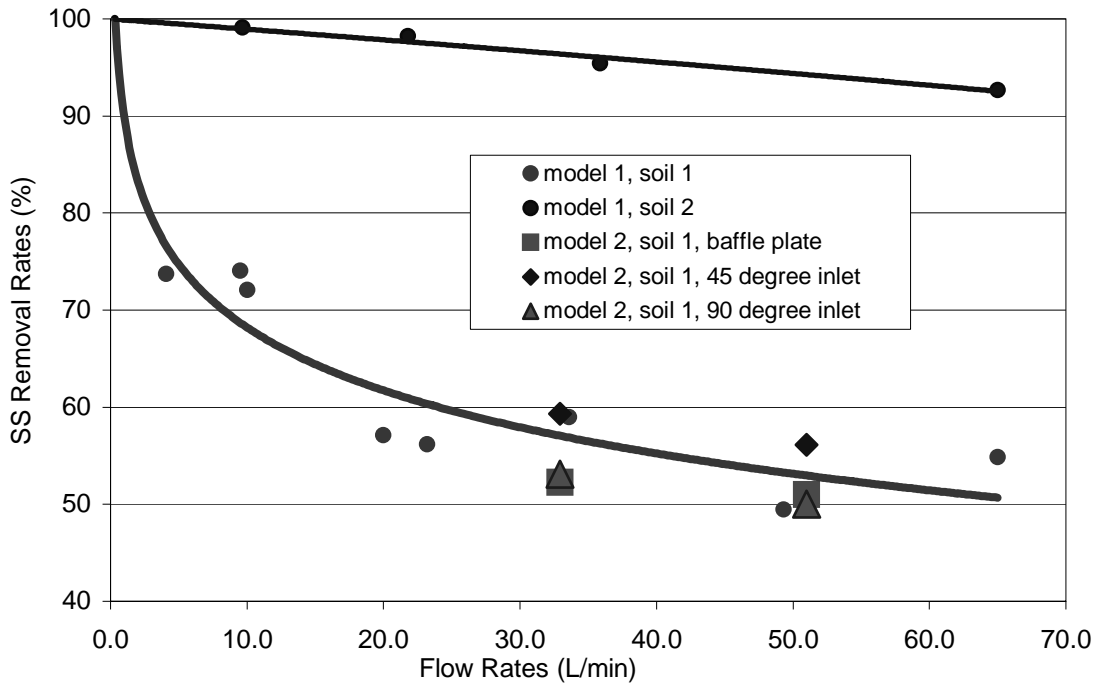


**Figure 3**



Soil Type 1 showed removal rates of 50 – 60% in the higher flow regimes. This would be expected for this soil type, given the smaller particle sizes and the flow rates used in the experiment. In tests with lower flow rates, the removal rates increased as the residence time increased. This again would be expected with any soil distribution which might be used in the system. Soil Type 1, for the most part, consisted of very fine particles such as silts and clays. The performance of the SWQU using these particle sizes was excellent considering they were outside the design of the unit. A graph of the removal rates for both soil types can be seen in Figure 4.

**Figure 4**





Soil Type 2 consisted of particles which generally were larger than the 200 sieve and larger than the soils in Type 1. These soils, because of their larger size, allowed for less residence time in the unit and still maintained high removal rates. The removal rates for these particle sizes were over 90% for the flow regimes tested. The soils which were present in this classification range were particles which are targeted for removal in the ADS Water Quality Unit.

### Scaling of Lab Data

Laboratory testing is a convenient method for testing practical theories and design principles. It provides a method to use a controlled environment and change the appropriate variables to try and achieve the desired results. This is especially true when scale models can be used to reduce the cost and logistics of testing large devices. Once the testing is complete it must be scaled to the appropriate standard to produce results which can be predicted in the real world. In the case of the ADS SWQU it requires that the unit be scaled up in order for flow rates and SWQU sizes to be appropriate for application.

Two methods for scaling the laboratory data are discussed here. They are the “surface load method” and the “horizontal flow velocity” method.

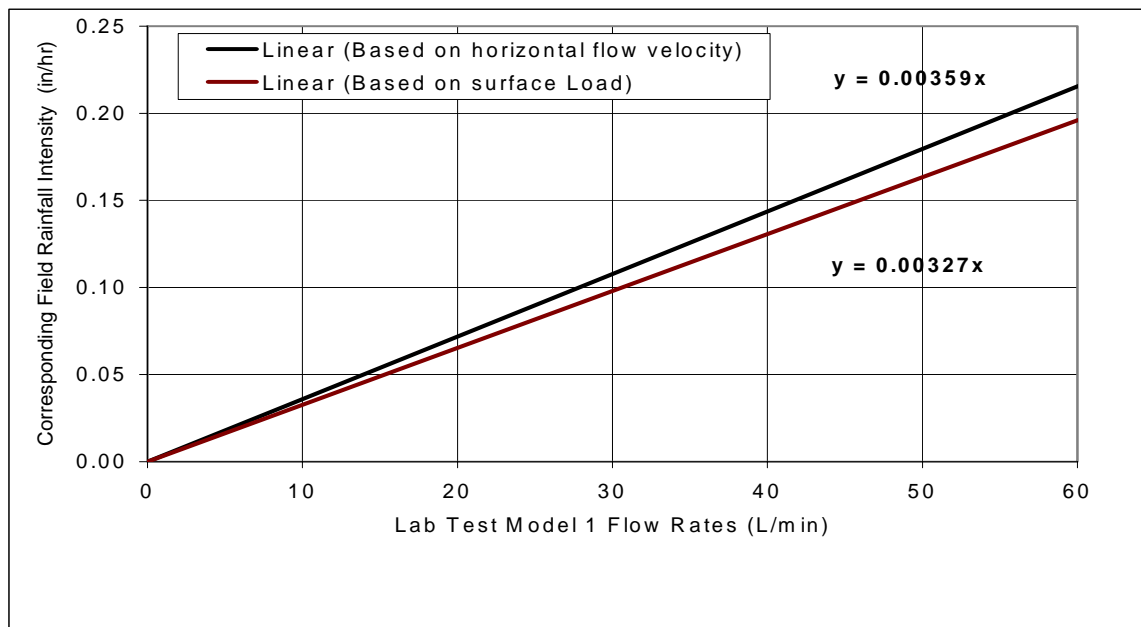
The surface flow method is defined by the following equation:

$$\text{Surface load} = \text{overflow rate} = \text{flow rate} / \text{surface area}$$

(Tchobanoglous and Franklin, 1991)

The horizontal flow velocity simply takes the runoff rate and converts it to a flow based on pipe diameter to get a flow velocity. If both of these methods are used, a chart comparing field rainfall intensity to laboratory flow data can be developed, as shown below in Figure 5.

**Figure 5**





## Alden Labs Maine DEP Laboratory Testing Protocol:

In addition to the scale model testing which was performed at Ohio University, full scale laboratory testing was performed at Alden Laboratories in Holden, Mass. Alden Labs tested the SWQU for conformance with the Maine Department of Environmental Protection Protocol for total suspended solids (TSS) removal. The Maine DEP protocol was put in place to provide a fair and unbiased mechanism for the evaluation of competitive manufactured water quality treatment devices. The protocol calls for the injection of a test media into the treatment flow at a predetermined concentration. The concentration is held at these levels and required residence time is computed. Samples are taken for background levels, influent levels, and effluent levels. The material collected in each sample is then filtered out and appropriately dried. Once the material is dried, it is weighed and the concentration of the total suspended solids is determined.

For the ADS SWQU, a 60-inch diameter, full scale unit was used. The unit was placed in a test loop at Alden Labs which consisted of the SWQU and the necessary support structure to run the tests. The testing was conducted on a standard 60" unit with a few small modifications to provide for accessibility and conformance to the requirements of the system loop. The modifications included an increase in the size of the risers to 36", the introduction of flanges on the inlet and outlet sides of the unit, and the insertion of small diameter pipe at the invert on the inlet and outlet side. The 36" risers were added primarily as inspection risers and for access into the system in case modifications or changes in the monitoring and testing procedure were required. In addition, the large risers provided easier access for the system to be cleaned out between tests. The flanges were provided on the inlet and outlet side of the unit to allow the SWQU to be inserted into the test loop, and to provide a watertight connection for the testing procedure. The small diameter pipe at the invert was put in place to allow the unit to be easily drained and cleaned out for subsequent tests at differing flow rates. In all other regards the unit tested was a standard ADS SWQU with appropriate weir spacing and weir heights. A drawing of the unit is shown in Figures 6A & B.

Figure 6A

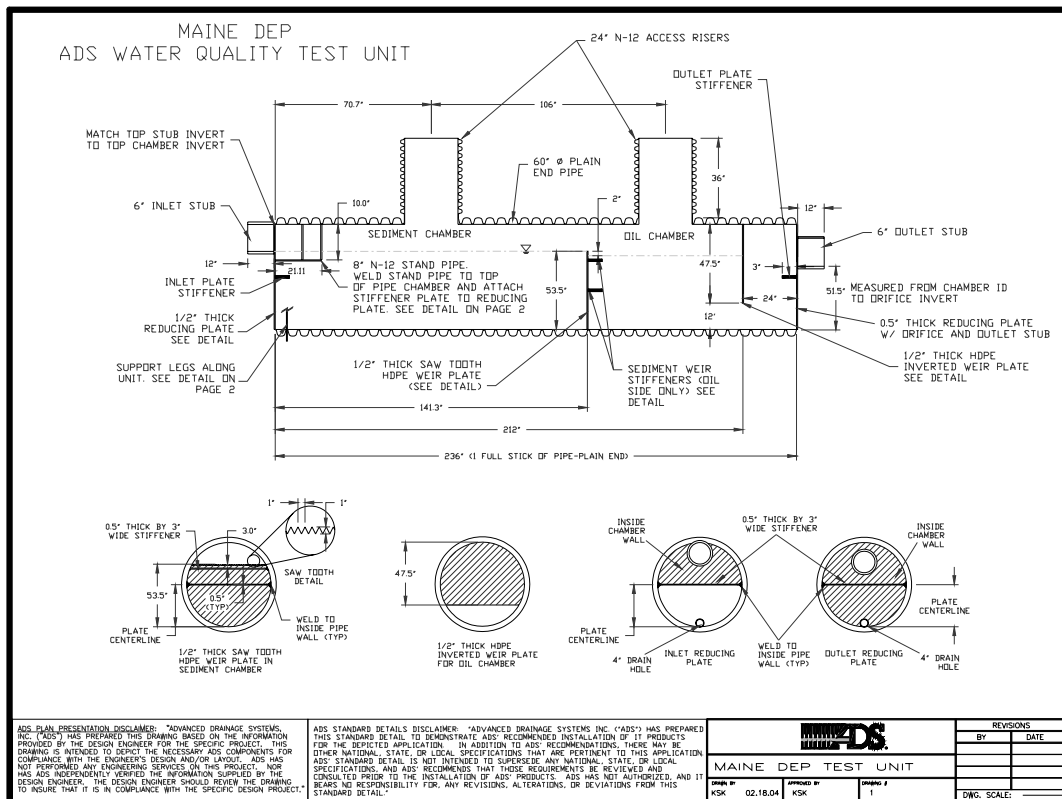
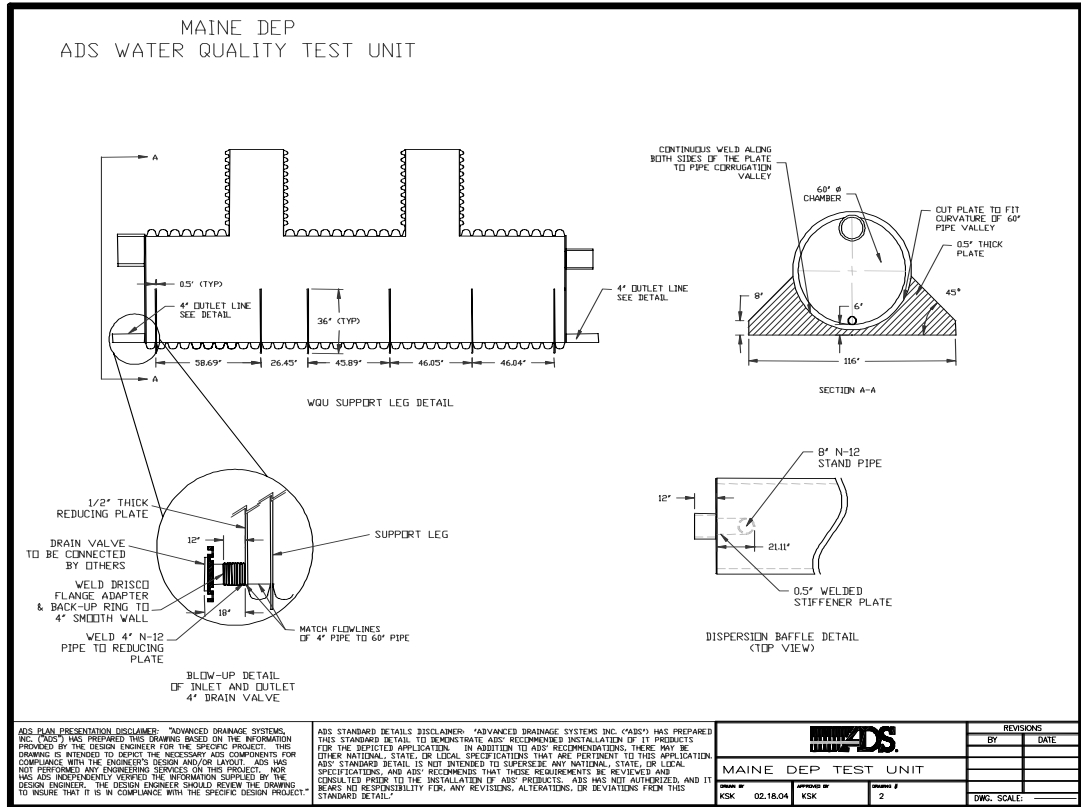


Figure 6B



The testing of the unit was run at various flow rates in order to determine the variance in the levels of efficiency for the SWQU based on flow rate and residence time. The concentration of sediment was approximately 250 mg/L. Each test run consisted of 5 inlet and outlet sample pairs to provide an adequate data set for the testing on the unit. The timing of the samples was such that the residence time in the unit was taken into account to provide samples which were coordinated with each other. A picture of the test unit in the testing loop is shown in Figure 7.



**Figure 7**



The test media used consisted of two different sands manufactured by U.S. Silica. The F-95 sand has a larger particle size and the OK-110 sand has a smaller particle size. The sieve analysis for each product is shown Table 1.

**Table 1**

**U.S Silica Test Media**

| US Std. Sieve | % Retained |        |
|---------------|------------|--------|
|               | F-95       | OK-110 |
| 30            |            | 0      |
| 40            | <1         | 0      |
| 50            | 1          | 0      |
| 70            | 9          | 0      |
| 100           | 60         | 1      |
| 120           |            | 15     |
| 140           | 42         | 48     |
| 170           |            | 24.2   |
| 200           | 15         | 9.7    |
| 270           | 3          | 1.9    |
| Pan           | <1         | 0.2    |

Multiple tests were conducted on the unit to provide a comprehensive analysis of the performance of the unit at various flow rates. The targeted flow rate based on Stoke's Law for the 60-inch Water Quality Unit is 1.47 cfs. Tests were conducted on the unit above and below the unit's anticipated flow rate to determine the performance limitations. For the 1.5 cfs. test, the average removal rate for the OK-110 sand was 88.3%. As a result of this testing, a scaling factor can be used to correlate the results with different size SWQU's and indicates that the design for the units is accurate. Scaling to other size units is accomplished by the following equation:

$$Q_{treatment} = (0.016949cfs / ft^2)(area)$$



As a result, the treatment rates from testing at Alden Labs compare favorably to our recommendations for flow rates through the unit based on the theoretical design. Table 2 shows the tested flow rates compared to the recommended rate.

**Table 2**

| Product No. | Minimum Treatment Chamber Area (sf) | Maximum treated flow (cfs) (tested) | Design Treated Flow (cfs) (recommended) |
|-------------|-------------------------------------|-------------------------------------|---|
| 3620WQB     | 55.50                               | 0.94                                | 0.7                                     |
| 3640WQB     | 111.00                              | 1.88                                | 1.6                                     |
| 4220WQB     | 64.43                               | 1.09                                | 0.86                                    |
| 4240WQB     | 128.86                              | 2.18                                | 1.83                                    |
| 4820WQB     | 71.40                               | 1.21                                | 1.13                                    |
| 4840WQB     | 142.80                              | 2.42                                | 2.39                                    |
| 6020WQB     | 88.50                               | 1.50                                | 1.47                                    |
| 6040WQB     | 177.00                              | 3.00                                | 3.12                                    |

For design purposes the Design Treated Flow rate should be used. As a follow up to the total suspended solids testing, further study of the Water Quality Unit was conducted to determine the oil removal efficiency of the unit.

## Alden Labs Oil Removal Testing

The same 60-inch diameter SWQU that was used in the total suspended solids removal testing at Alden Labs was also used for the oil removal study. The unit was again slightly modified to provide for an accurate determination of the oil removal efficiency of the unit. A skimmer wall, retraction assembly, and sidewall blockage areas were added to confine the oil collected so that it could be easily identified

Soybean based vegetable oil was used as the test medium. The density of the oil was approximately 0.92 g/ml. Oil was introduced into the system by use of a pump, which was calibrated prior to testing to determine the relationship between pump speed and the oil feed rate. Once again, the background levels were recorded to determine any influence from the water used in the system. The SWQU was tested with flow rates ranging from 0.5 cfs. to 2 cfs. The oil injection concentration ranged from 50 to 100mg/L. The tests were run for a period of 1 to 2 hours, depending on the influent flow, until approximately 10 liters of oil were injected into the unit. After the flow oil was discontinued, the unit was allowed to operate for a period of time to make sure that all of the oil had been injected into the unit and that the water volume carrying the oil had passed through. Flow rates and removal efficiencies are shown in Table 3.



**Table 3**

**Oil Removal Efficiencies**

| <b>Flow Rate<br/>(cfs)</b> | <b>Removal Efficiency<br/>(%)</b> |
|----------------------------|-----------------------------------|
| 0.5                        | 95                                |
| 1                          | 87                                |
| 1.5                        | 80                                |
| 2                          | 57                                |

Once again the flow rate targeted for design purposes is 1.5 cfs for the 60" unit. This would show an 80% removal rate. The scaling of this information remains the same as shown in the previous section.

## Field Testing and Research

Due to the complexities of field research and the dependence on the weather for cooperation, field testing requires more time and resources. Also, because of the lack of control on all of the variables, the results can be somewhat inconsistent and often require more analysis when completed. However, the field data and testing when approached correctly, can provide valuable information for further enhancements and improvements. The SWQU is being tested in several field installations. Because of the time required to complete these studies none of the current field studies have been completed, but some of them are yielding preliminary information. The studies currently underway are as follows:

- University of New Hampshire Center for Stormwater Technology**
- Nashville Study of Eight Water Quality Units**
- Mississippi Testing of Water Quality Units**

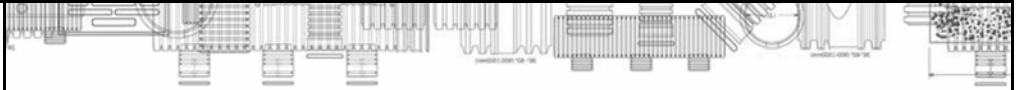
The status of each study is summarized below.

### **University of New Hampshire Center for Stormwater Technology**

This study consists of a Water Quality Unit and a perforated retention system in series on the site. The site is a study area for several different manufactured and natural stormwater treatment and control devices. The entire 8 acres that the property is located on is the drainage area from a parking lot for the University. The runoff collected from the site is urban and generates sediment, oil and grease. The storm water is metered to all the different devices on the site so that each treatment device receives 1 cfs. The stormwater is sampled on the influent and effluent sides to provide TSS and Floatable Removal Rate. Several other parameters are also tested at this site, including heavy metals, organics, and nutrients. The samplers used are automatic and the information is collected centrally for ease of access.

In addition, the site has been studied from a hydrologic standpoint to provide detailed data on rainfall and runoff rates. From this data, storms which provide adequate parameters are selected to provide the sample data set. A full set of data and the parameters for testing are available upon request. Preliminary results are not publicly available at this time.





## Nashville Study of Eight Water Quality Units

This study consists of eight Water Quality Units located at various sites around the metro Nashville area. The testing was conducted by Qore Property Sciences and the final report was issued on June 23, 2005. The eight units were each tested for one storm event within each unit's treatment capacity. The samples were collected in accordance with the Technology Acceptance Reciprocity Partnership (TARP) Protocol for Stormwater BMP demonstrations. The testing was done in accordance with ASTM 3977-97, Standard Test Method for Determining Sediment Concentration in Water Samples, for the range of particles specified by Nashville using the No.10 to the No.140 sieve. Results from the testing are shown in the Table 4.

**Table 4**

| Location  | Unit Diameter | Sieve # | Weight Retained Influent (Grams) | Weight Retained Effluent (Grams) | Percent Removed |
|---|---------------|---------|----------------------------------|----------------------------------|-----------------|
| Occupational Health<br>4300 Sidco Drive                     | 48"           | 140     | 8.28                             | 0.14                             | 98              |
| Jim and Nick's BBQ<br>7004 Charlotte Pike                   | 60"           | 140     | 2.99                             | 0.05                             | 98              |
| Autowash<br>7006 Charlotte Pike                             | 36"           | 140     | 1.5                              | 0.3                              | 80              |
| Shurgard Storage<br>2360 Gallatin Road                      | 48"           | 140     | 4.59                             | 0.21                             | 95              |
| Southern Unit:<br>Walgreen's HWY 100<br>at Old Harding Pike | 48"           | 140     | 1.81                             | 0.13                             | 93              |
| Taco Bell<br>2904 Gallatin Road                             | 48"           | 140     | 1.21                             | 0.08                             | 93              |
| High Tech Institute<br>560 Royal Parkway                    | 42"           | 140     | 0.88                             | 0.08                             | 91              |
| DMW Expedite<br>1850 Elm Hill Pike                          | 48"           | 140     | 1.22                             | 0.21                             | 83              |

In addition to the results summarized in Table 4, an analysis of particle sizes ranging from the No.10 to the No.200 sieve was also conducted. The samples taken were in accordance with TARP protocol and ASTM 3977-97 was used to determine the resulting efficiencies. A summary of the results is shown in Table 5.





**Table 5**

| Location  | Unit Diameter | Sieve # | Weight Retained Influent (Grams) | Weight Retained Effluent (Grams) | Percent Removed |
|---|---------------|---------|----------------------------------|----------------------------------|-----------------|
| Occupational Health<br>4300 Sidco Drive                     | 48"           | 200     | 8.29                             | 0.15                             | 98              |
| Jim and Nick's BBQ<br>7004 Charlotte Pike                   | 60"           | 200     | 3.29                             | 0.07                             | 98              |
| Autowash<br>7006 Charlotte Pike                             | 36"           | 200     | 1.7                              | 0.31                             | 82              |
| Shurgard Storage<br>2360 Gallatin Road                      | 48"           | 200     | 4.6                              | 0.21                             | 95              |
| Southern Unit:<br>Walgreen's HWY 100<br>at Old Harding Pike | 48"           | 200     | 1.99                             | 0.15                             | 93              |
| Taco Bell<br>2904 Gallatin Road                             | 48"           | 200     | 1.2                              | 0.1                              | 92              |
| High Tech Institute<br>560 Royal Parkway                    | 42"           | 200     | 0.94                             | 0.1                              | 89              |
| DMW Expedite<br>1850 Elm Hill Pike                          | 48"           | 200     | 1.62                             | 0.34                             | 79              |

### Mississippi Testing of Water Quality Units

The Mississippi testing consists of 5 individual Water Quality Units on a single site in Mississippi. The units are located on a Lowes commercial building site. The units have been installed, have been cleaned out from construction operations, and are ready to begin testing. No results are available at this time.

## Conclusions

The ADS SWQU can provide significant treatment for stormwater quality on a variety of stormwater projects. The treatment of both settling and floating pollutants provides a good first level management technique. This provides the opportunity to use the device in both a stand-alone configuration or as the first step in a treatment train.



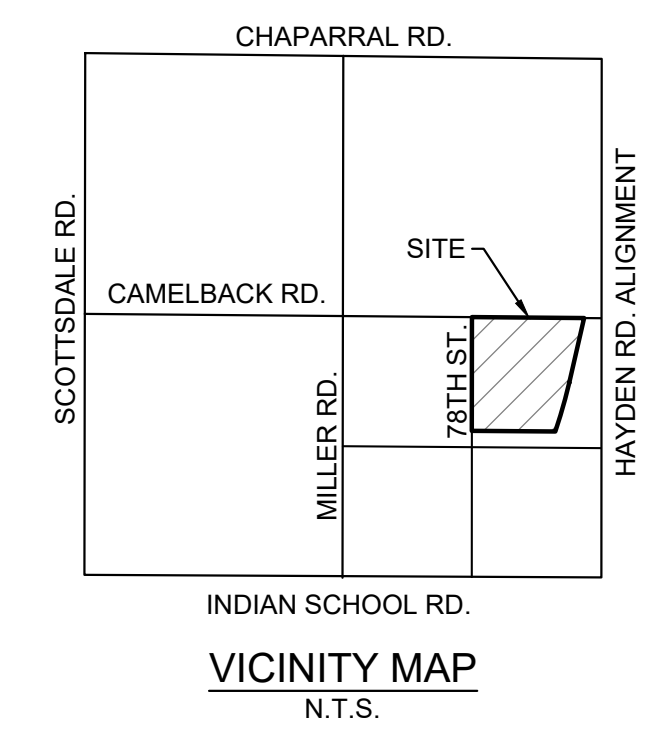
COPYRIGHT © 2019 ATWELL LLC NO REPRODUCTION SHALL BE MADE WITHOUT THE PRIOR WRITTEN CONSENT OF ATWELL LLC

6119001704 - vicente-glen-consentdwgplans\atwell\concept\grading & drainage\19001704-01-cd01.dwg 1/20/19 6/12/2019

**LEGEND**

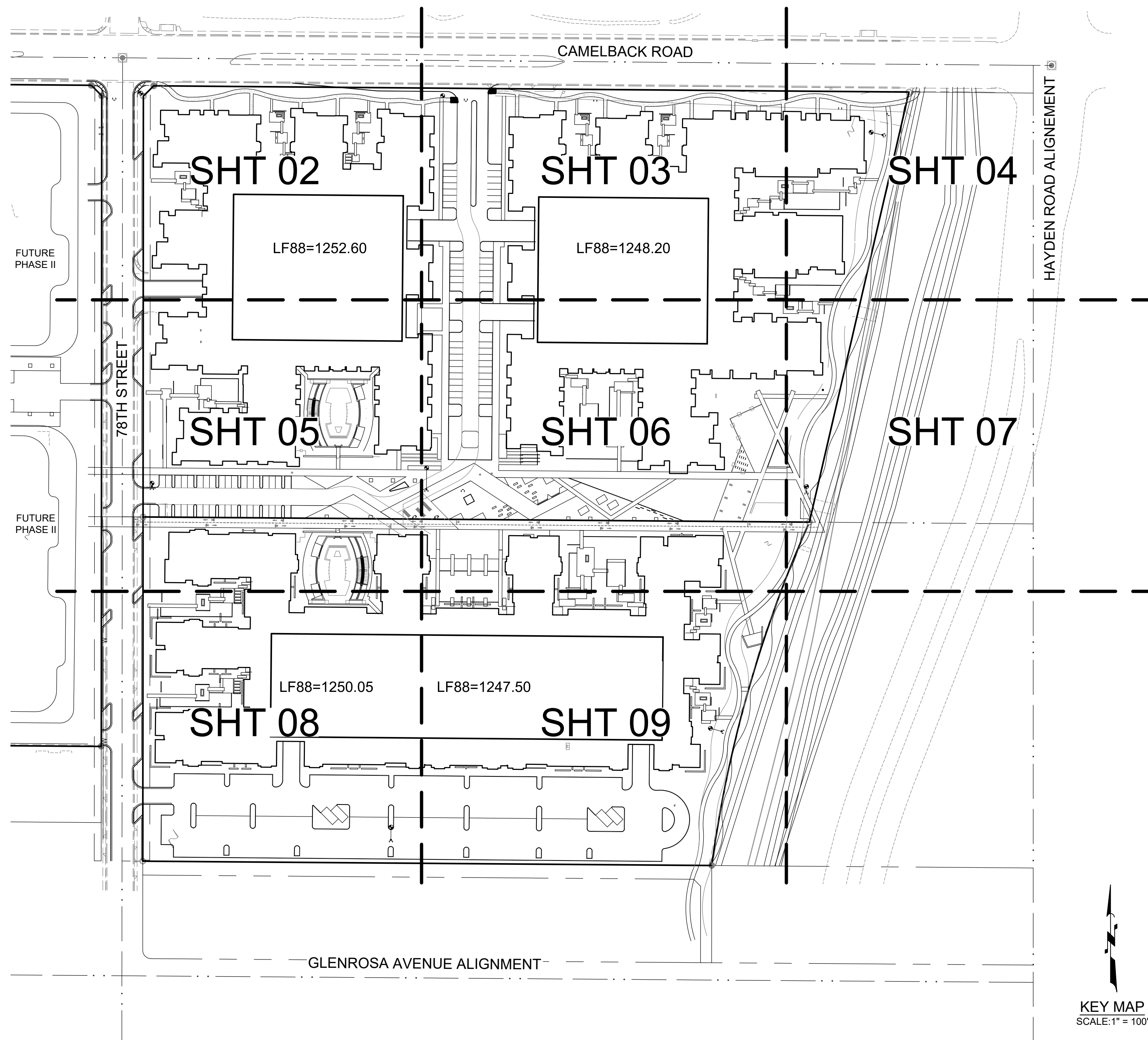
- |  |                                 |       |                             |
|--|---------------------------------|-------|-----------------------------|
|  | MATCHLINE                       | R     | RIGHT                       |
|  | BOUNDARY LINE                   | L     | LEFT                        |
|  | LOT LINE                        | PC    | POINT OF CURVATURE          |
|  | CAP SURVEY MARKER               | PCC   | POINT OF COMPOUND CURVATURE |
|  | CENTER LINE                     | PRC   | POINT OF REVERSE CURVATURE  |
|  | EASEMENT                        | PT    | POINT OF TANGENCY           |
|  | RIGHT-OF-WAY                    | GB    | GRADE BREAK                 |
|  | EXISTING CONTOUR                | STA=  | STATION                     |
|  | PROPOSED CONTOUR                | STA:  | STATION                     |
|  | RETAINING WALL                  | INV   | INVERT ELEVATION            |
|  | WATER LINE                      | VG    | VALLEY GUTTER               |
|  | FIRE HYDRANT                    | FL    | FLOW LINE                   |
|  | WATER VALVE                     | TC    | TOP OF CURB                 |
|  | AIR RELEASE VALVE               | TL    | TRUE LENGTH                 |
|  | WATER METER BOX                 | P     | PAVEMENT                    |
|  | REDUCER                         | C1    | CURVE TABLE NUMBER          |
|  | SEWER LINE                      | L1    | LINE TABLE NUMBER           |
|  | SEWER MANHOLE                   | LF    | LINEAR FEET                 |
|  | FLOW DIRECTION                  | SF    | SQUARE FEET                 |
|  | GRADE BREAK                     | SY    | SQUARE YARDS                |
|  | STREET SIGN POST                | CY    | CUBIC YARDS                 |
|  | STREET LIGHTS                   | EA    | EACH                        |
|  | DRYWELL                         | EX    | EXISTING                    |
|  | STORM DRAIN                     | RW    | RIGHT-OF-WAY                |
|  | EXISTING GAS MANHOLE            | CL    | CENTER LINE                 |
|  | EXISTING SANITARY SEWER MANHOLE | B/C   | BACK OF CURB                |
|  | EXISTING ELECTRICAL PULL BOX    | SW    | SIDEWALK                    |
|  | EXISTING TELEPHONE PEDISTAL     | C&G   | CURB & GUTTER               |
|  | EXISTING GUY WIRE               | EOP   | EDGE OF PAVEMENT            |
|  | EXISTING POWER POLE             | PUE   | PUBLIC UTILITY EASEMENT     |
|  | EXISTING WATER                  | SC    | SCUPPER                     |
|  | EXISTING SEWER                  | CB    | CATCH BASIN                 |
|  | EXISTING GAS                    | W=    | WIDTH                       |
|  | EXISTING OVERHEAD UTILITY LINES | MH#   | SEWER MANHOLE               |
|  |                                 | SD    | STORM DRAIN                 |
|  |                                 | SD MH | STORM DRAIN MANHOLE         |

# CONCEPTUAL GRADING & DRAINAGE PLAN FOR PHASE I OF GENTRY ON THE GREEN SCOTTSDALE, ARIZONA



THE LOCATIONS OF EXISTING UNDERGROUND UTILITIES ARE SHOWN IN AN APPROXIMATE WAY ONLY AND HAVE NOT BEEN INDEPENDENTLY VERIFIED BY THE OWNER OR ITS REPRESENTATIVE. THE CONTRACTOR SHALL DETERMINE THE EXACT LOCATION OF ALL EXISTING UTILITIES BEFORE COMMENCING WORK AND AGREES TO BE FULLY RESPONSIBLE FOR ANY AND ALL DAMAGES WHICH MIGHT BE OCCASIONED BY THE CONTRACTOR'S FAILURE TO EXACTLY LOCATE AND PRESERVE ANY AND ALL UNDERGROUND UTILITIES.

NOTICE: CONSTRUCTION SITE SAFETY IS THE SOLE RESPONSIBILITY OF THE CONTRACTOR. NEITHER THE OWNER NOR THE ENGINEER SHALL BE EXPECTED TO ASSURE ANY RESPONSIBILITY FOR SAFETY OF THE WORK OF PERSONS ENGAGED IN THE WORK OF ANY NEARBY STRUCTURES, OR OF ANY OTHER PERSONS.



**OWNER/DEVELOPER**  
COLRICH  
444 WEST BEACH STREET, STE. 300  
SAN DIEGO, CA 92101  
PHONE: 858.490.2300  
CONTACT: MATTHEW BATEMAN  
EMAIL:

**ENGINEER**  
ATWELL  
4700 E. SOUTHERN AVENUE  
MESA, AZ 85206  
PHONE: 602.690.7527  
CONTACT: RAMZI GEORGES  
EMAIL: rgeorges@atwell-group.com

**SHEET INDEX**

| SHEET No. | DESCRIPTION             |
|-----------|-------------------------|
| 01        | COVER SHEET             |
| 02        | GRADING & DRAINAGE PLAN |
| 03        | GRADING & DRAINAGE PLAN |
| 04        | GRADING & DRAINAGE PLAN |
| 05        | GRADING & DRAINAGE PLAN |
| 06        | GRADING & DRAINAGE PLAN |
| 07        | GRADING & DRAINAGE PLAN |
| 08        | GRADING & DRAINAGE PLAN |
| 09        | GRADING & DRAINAGE PLAN |

**KEY MAP**  
SCALE: 1" = 100'

**ATWELL**  
866.850.4200 www.atwell-group.com  
4700 E. SOUTHERN AVENUE  
MESA, AZ 85206  
402.76.8661

COVER SHEET  
CONCEPTUAL GRADING & DRAINAGE PLAN  
PHASE I OF GENTRY ON THE GREEN  
SCOTTSDALE, ARIZONA

Know what's below.  
Call before you dig.

**REVISIONS:**

| NO. | DESCRIPTION |
|-----|-------------|
|     |             |
|     |             |
|     |             |
|     |             |
|     |             |
|     |             |
|     |             |
|     |             |
|     |             |

|                              |
|------------------------------|
| PM. R. GEORGES               |
| DR. A. CABALLERO             |
| JOB NO.<br>19001704          |
| FILE NO.<br>19001704-01-CS01 |
| <b>01</b>                    |
| SHEET NO.<br><b>01 OF 11</b> |

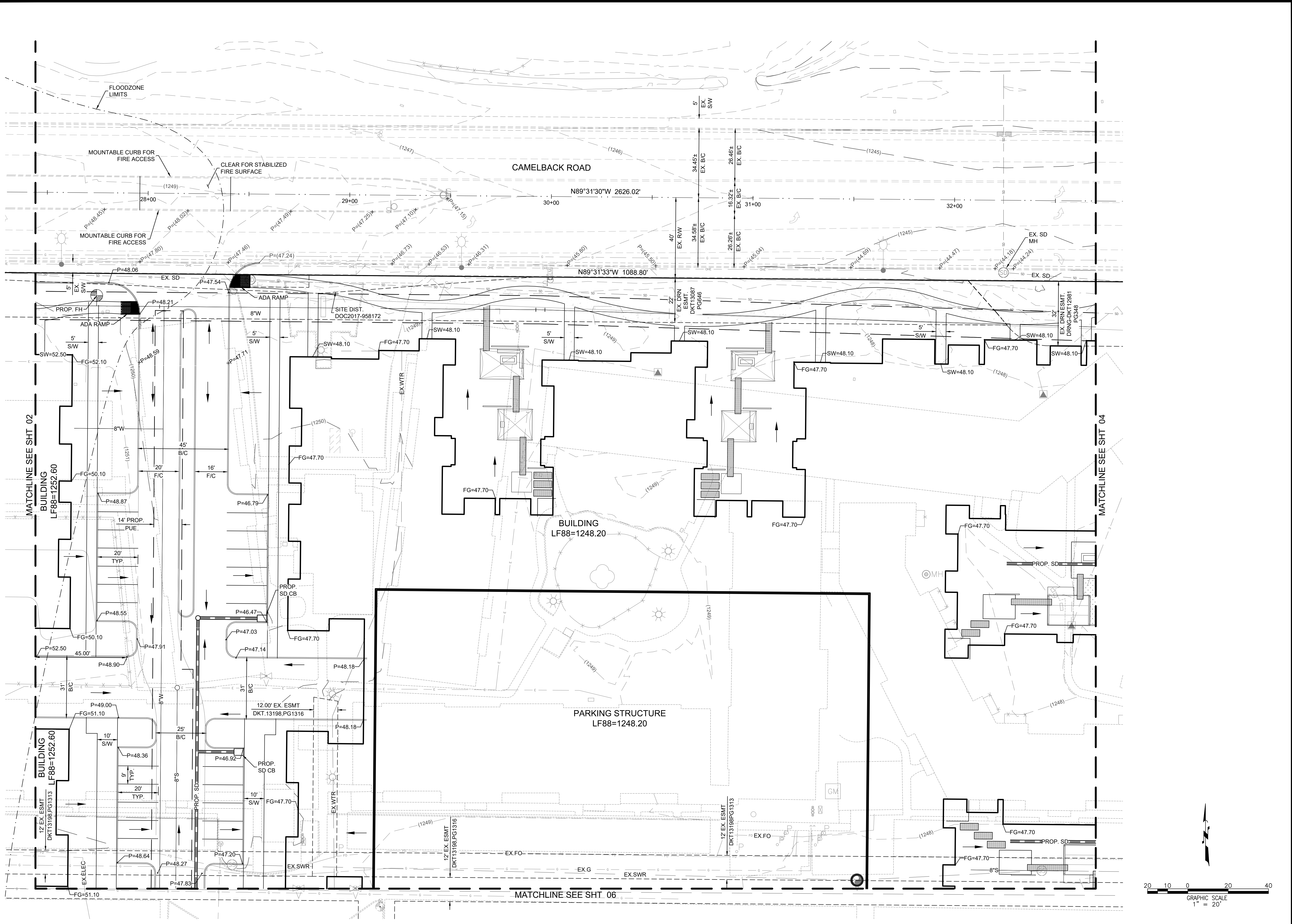
PROJECT NUMBER







COPYRIGHT © 2019 ATWELL LLC. NO REPRODUCTION SHALL BE MADE WITHOUT THE PRIOR WRITTEN CONSENT OF ATWELL LLC.



THE LOCATIONS OF EXISTING UNDERGROUND UTILITIES ARE SHOWN IN AN APPROXIMATE WAY ONLY AND HAVE NOT BEEN INDEPENDENTLY VERIFIED BY THE OWNER OR ITS REPRESENTATIVE. THE CONTRACTOR SHALL DETERMINE THE EXACT LOCATION OF ALL EXISTING UTILITIES BEFORE COMMENCING WORK AND AGREES TO BE FULLY RESPONSIBLE FOR ANY AND ALL DAMAGES WHICH MIGHT BE OCCASIONED BY THE CONTRACTOR'S FAILURE TO EXACTLY LOCATE AND PRESERVE ANY AND ALL UNDERGROUND UTILITIES.

NOTICE: CONSTRUCTION SITE SAFETY IS THE SOLE RESPONSIBILITY OF THE CONTRACTOR. NEITHER THE OWNER NOR THE ENGINEER SHALL BE EXPECTED TO ASSUME ANY RESPONSIBILITY FOR SAFETY OF THE WORK OF PERSONS ENGAGED IN THE WORK OF ANY NEARBY STRUCTURES, OR OF ANY OTHER PERSONS.



GRADING & DRAINAGE PLAN  
CONCEPTUAL GRADING & DRAINAGE PLAN  
PHASE I OF GENTRY ON THE GREEN  
SCOTTSDALE, ARIZONA

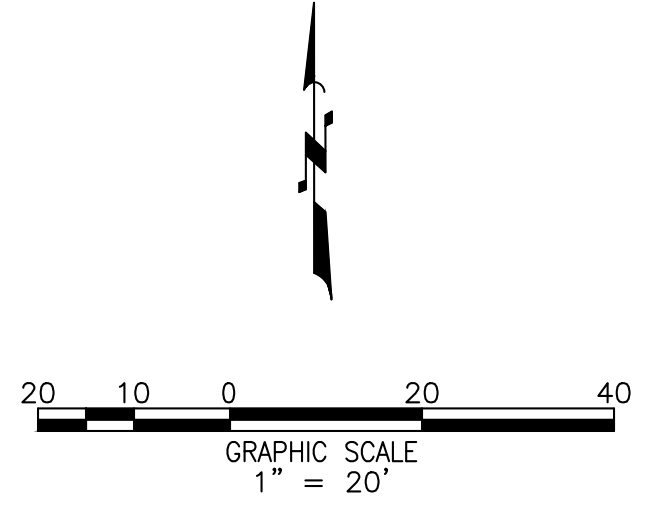


REVISIONS:

| NO. | DESCRIPTION | DATE |
|-----|-------------|------|
|     |             |      |
|     |             |      |
|     |             |      |
|     |             |      |
|     |             |      |
|     |             |      |
|     |             |      |
|     |             |      |
|     |             |      |
|     |             |      |



PM. R. GEORGES  
DR. A. CABELLERO  
JOB NO. 19001704  
FILE NO. 19001704-03-GD02  
03















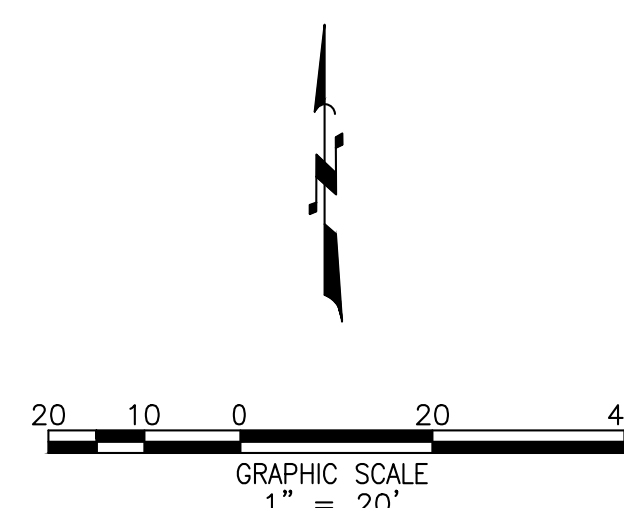
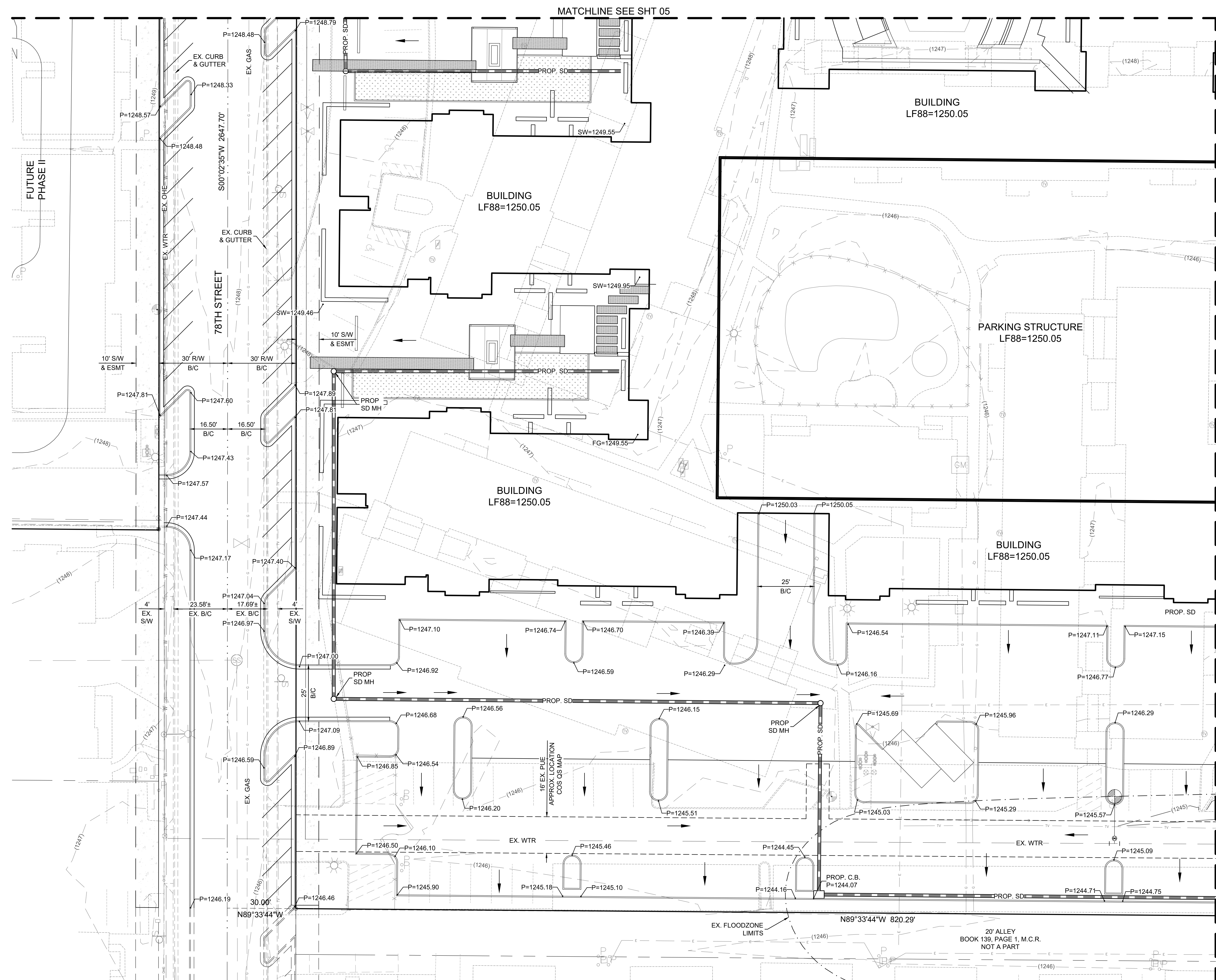






COPYRIGHT © 2019 ATWELL LLC. NO REPRODUCTION SHALL BE MADE WITHOUT THE PRIOR WRITTEN CONSENT OF ATWELL LLC.

19001704 - vicente-ghis-consent-grading-plan-19001704-08-gd07.dwg Plotdate: 04/20/19



THE LOCATIONS OF EXISTING UNDERGROUND UTILITIES ARE SHOWN IN AN APPROXIMATE WAY ONLY AND HAVE NOT BEEN INDEPENDENTLY VERIFIED BY THE OWNER OR ITS REPRESENTATIVE. THE CONTRACTOR SHALL DETERMINE THE EXACT LOCATION OF ALL EXISTING UTILITIES BEFORE COMMENCING WORK, AND AGREES TO BE FULLY RESPONSIBLE FOR ANY AND ALL DAMAGES WHICH MIGHT BE OCCASIONED BY THE CONTRACTOR'S FAILURE TO EXACTLY LOCATE AND PRESERVE ANY AND ALL UNDERGROUND UTILITIES.

NOTICE: CONSTRUCTION SITE SAFETY IS THE SOLE RESPONSIBILITY OF THE CONTRACTOR. NEITHER THE OWNER NOR THE ENGINEER SHALL BE EXPECTED TO ASSUME ANY RESPONSIBILITY FOR SAFETY OF THE WORK OF PERSONS ENGAGED IN THE WORK OF ANY NEARBY STRUCTURES, OR OF ANY OTHER PERSONS.



**GRADING & DRAINAGE PLAN**  
CONCEPTUAL GRADING & DRAINAGE PLAN  
**PHASE I OF ENTRY ON THE GREEN**  
SCOTTSDALE, ARIZONA



REVISIONS:

| NO. | DESCRIPTION |
|-----|-------------|
|     |             |
|     |             |
|     |             |
|     |             |
|     |             |
|     |             |
|     |             |
|     |             |
|     |             |
|     |             |

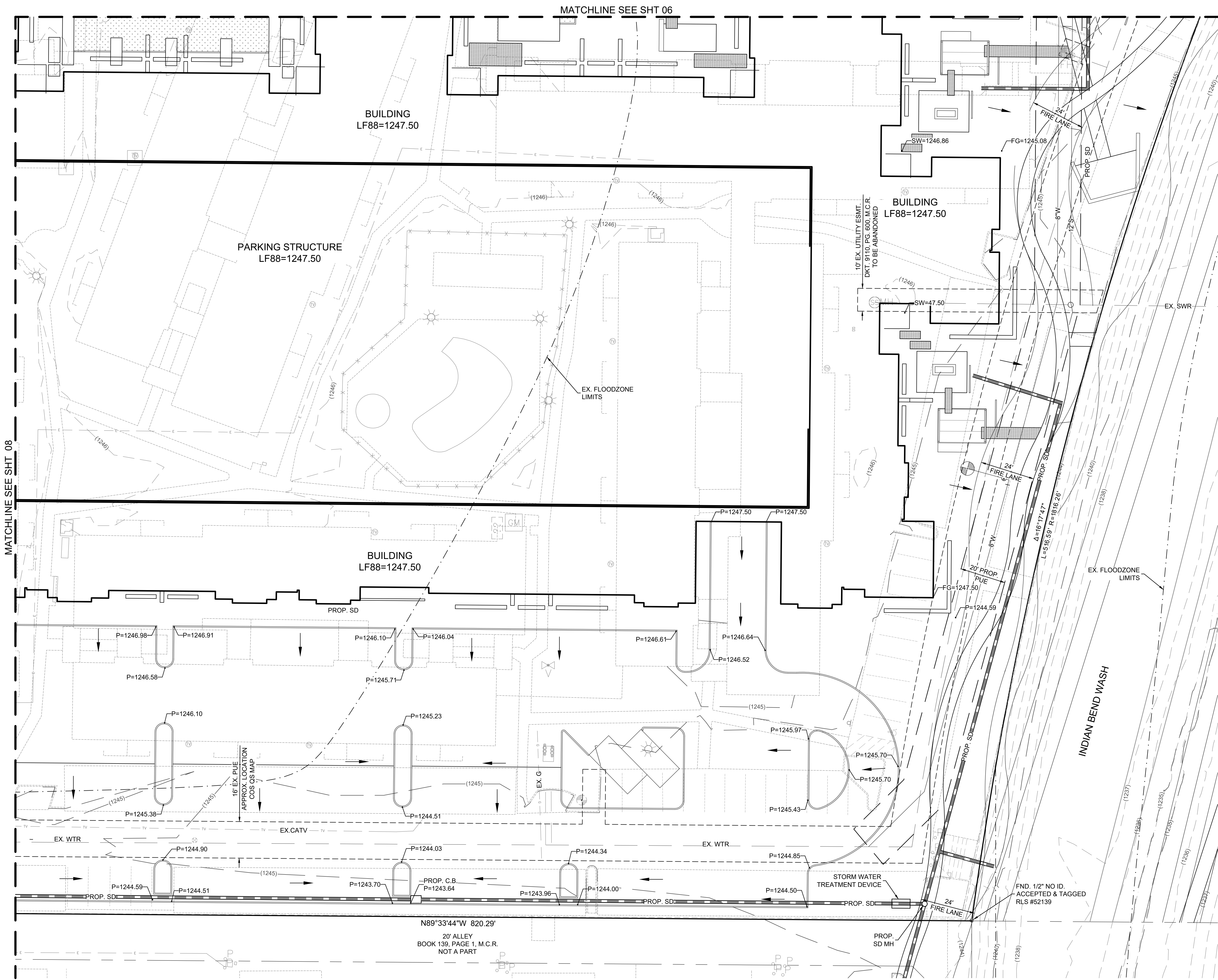


PM. R. GEORGES  
DR. A. CABALLERO  
JOB NO. 19001704  
FILE NO. 19001704-08-GD07

**08**  
SHEET NO.  
**08 OF 11**

PROJECT NUMBER





THE LOCATIONS OF EXISTING UNDERGROUND UTILITIES ARE SHOWN IN AN APPROXIMATE WAY ONLY AND HAVE NOT BEEN INDEPENDENTLY VERIFIED BY THE OWNER OR ITS REPRESENTATIVE. THE CONTRACTOR SHALL DETERMINE THE EXACT LOCATION OF ALL EXISTING UTILITIES BEFORE COMMENCING WORK, AND AGREES TO BE FULLY RESPONSIBLE FOR ANY AND ALL DAMAGES WHICH MIGHT BE OCCASIONED BY THE CONTRACTOR'S FAILURE TO EXACTLY LOCATE AND PRESERVE ANY AND ALL UNDERGROUND UTILITIES.

NOTICE: CONSTRUCTION SITE SAFETY IS THE SOLE RESPONSIBILITY OF THE CONTRACTOR. NEITHER THE OWNER NOR THE ENGINEER SHALL BE EXPECTED TO ASSUME ANY RESPONSIBILITY FOR SAFETY OF THE WORK OF PERSONS ENGAGED IN THE WORK, OF ANY NEARBY STRUCTURES, OR OF ANY OTHER PERSONS.

**ATWELL**  
 866.850.4200 www.atwell-group.com  
 4700 E SOUTHERN AVENUE  
 MESA, AZ 85206  
 480.216.8651

**GRADING & DRAINAGE PLAN**  
 CONCEPTUAL GRADING & DRAINAGE PLAN  
**PHASE I OF GENTRY ON THE GREEN**  
 SCOTTSDALE, ARIZONA

**811**  
 Know what's below.  
 Call before you dig.

REVISIONS:

|  |  |
|--|--|
|  |  |
|  |  |
|  |  |
|  |  |
|  |  |
|  |  |
|  |  |
|  |  |
|  |  |
|  |  |

Professional Engineer Seal  
 37287  
 RAMON GEORGE  
 6/14/2019  
 Signed  
 ARIZONA U.S.A.

PM. R. GEORGES  
 DR. A. CABELLERO  
 JOB NO. 19001704  
 FILE NO. 19001704-09-GD08  
**09**

SHEET NO.  
**09 OF 11**

PROJECT NUMBER